



3A1190H

EN

Airless Paint Sprayer

For portable spray application of architectural paints and coatings. For professional use only.

Airlessco Home Depot LP540 Hi Boy (331861) Series B

3000 psi (20.7 MPa, 207 bar) Maximum Working Pressure



IMPORTANT SAFETY INSTRUCTIONS

Read all warnings and instructions in this manual. Be familiar with the controls and the proper usage of the equipment. Save these instructions.

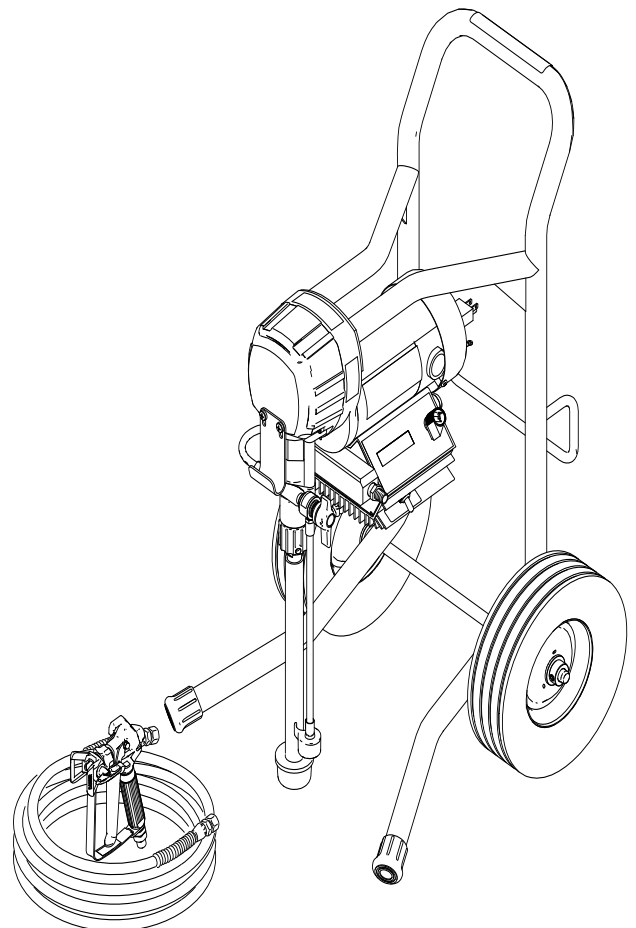

ti16047a

3172585
Certified to CAN/CSA C22. No. 68
Conforms to UL 1450



Warnings

The following warnings are for the setup, use, grounding, maintenance, and repair of this equipment. The exclamation point symbol alerts you to a general warning and the hazard symbols refer to procedure-specific risks. When these symbols appear in the body of this manual or warning labels, refer back to these Warnings. Product-specific hazard symbols and warnings not covered in this section may appear throughout the body of this manual where applicable.

WARNING



GROUNDING

This product must be grounded. In the event of an electrical short circuit, grounding reduces the risk of electric shock by providing an escape wire for the electric current. This product is equipped with a cord having a grounding wire with an appropriate grounding plug. The plug must be plugged into an outlet that is properly installed and grounded in accordance with all local codes and ordinances.

- Improper installation of the grounding plug is able to result in a risk of electric shock.
- When repair or replacement of the cord or plug is required, do not connect the grounding wire to either flat blade terminal.
- The wire with insulation having an outer surface that is green with or without yellow stripes is the grounding wire.
- Check with a qualified electrician or serviceman when the grounding instructions are not completely understood, or when in doubt as to whether the product is properly grounded.
- Do not modify the plug provided; if it does not fit the outlet, have the proper outlet installed by a qualified electrician.
- This product is for use on a nominal 120V circuit and has a grounding plug similar to the plug illustrated in the figure below.

120V US

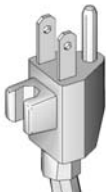

- Only connect the product to an outlet having the same configuration as the plug.
- Do not use an adapter with this product.

Extension Cords:

- Use only a 3-wire extension cord that has a grounding plug and a grounding receptacle that accepts the plug on the product.
- Make sure your extension cord is not damaged. If an extension cord is necessary, use 12 AWG (2.5 mm²) minimum to carry the current that the product draws.
- An undersized cord results in a drop in line voltage and loss of power and overheating.

WARNING



FIRE AND EXPLOSION HAZARD

Flammable fumes, such as solvent and paint fumes, in work area can ignite or explode. To help prevent fire and explosion:



- Do not spray or clean with materials having flash points lower than 100° F (38° C). Use only non-flammable or water-based materials, or non-flammable paint thinners. For complete information about your material, request the SDS from the material distributor or retailer.



- Do not spray flammable or combustible materials near an open flame or sources of ignition such as cigarettes, motors, and electrical equipment.



- Paint or solvent flowing through the equipment is able to result in static electricity. Static electricity creates a risk of fire or explosion in the presence of paint or solvent fumes. All parts of the spray system, including the pump, hose assembly, spray gun, and objects in and around the spray area shall be properly grounded to protect against static discharge and sparks. Use Graco conductive or grounded high-pressure airless paint sprayer hoses.

- Verify that all containers and collection systems are grounded to prevent static discharge. Do not use pail liners unless they are anti-static or conductive.

- Connect to a grounded outlet and use grounded extension cords. Do not use a 3-to-2 adapter.

- Do not use a paint or a solvent containing halogenated hydrocarbons.

- Do not spray combustible liquids in a confined area.

- Keep spray area well-ventilated. Keep a good supply of fresh air moving through the area.

- Spray generates sparks. Keep pump assembly in a well-ventilated area at least 20 feet (6.1 m) from the spray area when spraying, flushing, cleaning, or servicing. Do not spray pump assembly.

- Do not smoke in the spray area or spray where sparks or flame is present.

- Do not operate light switches, engines, or similar spark producing products in the spray area.

- Keep area clean and free of paint or solvent containers, rags, and other flammable materials.

- Know the contents of the paints and solvents being sprayed. Read all Safety Data Sheets (SDS) and container labels provided with the paints and solvents. Follow the paint and solvents manufacturer's safety instructions.

- Fire extinguisher equipment shall be present and working.



ELECTRIC SHOCK HAZARD

This equipment must be grounded. Improper grounding, setup, or usage of the system can cause electric shock.



- Turn off and disconnect power cord before servicing equipment.



- Use only grounded electrical outlets.

- Use only 3-wire extension cords.

- Ensure ground prongs are intact on power and extension cords.





- Do not expose to rain. Store indoors.

WARNING

	<p>SKIN INJECTION HAZARD</p> <p>High-pressure spray is able to inject toxins into the body and cause serious bodily injury. In the event that injection occurs, get immediate surgical treatment.</p> <ul style="list-style-type: none"> • Do not aim the gun at, or spray any person or animal. • Keep hands and other body parts away from the discharge. For example, do not try to stop leaks with any part of the body. • Always use the nozzle tip guard. Do not spray without nozzle tip guard in place. • Use Graco nozzle tips. • Use caution when cleaning and changing nozzle tips. In the case where the nozzle tip clogs while spraying, follow the Pressure Relief Procedure for turning off the unit and relieving the pressure before removing the nozzle tip to clean. • Equipment maintains pressure after power is shut off. Do not leave the equipment energized or under pressure while unattended. Follow the Pressure Relief Procedure when the equipment is unattended or not in use, and before servicing, cleaning, or removing parts. • Check hoses and parts for signs of damage. Replace any damaged hoses or parts. • This system is capable of producing 3000 psi. Use Graco replacement parts or accessories that are rated a minimum of 3000 psi. • Always engage the trigger lock when not spraying. Verify the trigger lock is functioning properly. • Verify that all connections are secure before operating the unit. • Know how to stop the unit and bleed pressure quickly. Be thoroughly familiar with the controls.
	<p>EQUIPMENT MISUSE HAZARD</p> <p>Misuse can cause death or serious injury.</p> <ul style="list-style-type: none"> • Always wear appropriate gloves, eye protection, and a respirator or mask when painting. • Do not operate or spray near children. Keep children away from equipment at all times. • Do not overreach or stand on an unstable support. Keep effective footing and balance at all times. • Stay alert and watch what you are doing. • Do not operate the unit when fatigued or under the influence of drugs or alcohol. • Do not kink or over-bend the hose. • Do not expose the hose to temperatures or to pressures in excess of those specified by Graco. • Do not use the hose as a strength member to pull or lift the equipment. • Do not spray with a hose shorter than 25 feet. • Do not alter or modify equipment. Alterations or modifications may void agency approvals and create safety hazards. • Make sure all equipment is rated and approved for the equipment in which you are using it.
	<p>PRESSURIZED ALUMINUM PARTS HAZARD</p> <p>Use of fluids that are incompatible with aluminum in pressurized equipment can cause serious chemical reaction and equipment rupture. Failure to follow this warning can result in death, serious injury, or property damage.</p> <ul style="list-style-type: none"> • Do not use 1,1,1-trichloroethane, methylene chloride, other halogenated hydrocarbon solvents or fluids containing such solvents. • Do not use chlorine bleach. • Many other fluids may contain chemicals that can react with aluminum. Contact your material supplier for compatibility.



WARNING

 	<p>MOVING PARTS HAZARD</p> <p>Moving parts can pinch, cut or amputate fingers and other body parts.</p> <ul style="list-style-type: none"> • Keep clear of moving parts. • Do not operate equipment with protective guards or covers removed. • Pressurized equipment can start without warning. Before checking, moving, or servicing equipment, follow the Pressure Relief Procedure and disconnect all power sources.
	<p>TOXIC FLUID OR FUMES HAZARD</p> <p>Toxic fluids or fumes can cause serious injury or death if splashed in the eyes or on skin, inhaled, or swallowed.</p> <ul style="list-style-type: none"> • Read Safety Data Sheet (SDS) to know the specific hazards of the fluids you are using. • Store hazardous fluid in approved containers, and dispose of it according to applicable guidelines.
	<p>PERSONAL PROTECTIVE EQUIPMENT</p> <p>Wear appropriate protective equipment when in the work area to help prevent serious injury, including eye injury, hearing loss, inhalation of toxic fumes, and burns. Protective equipment includes but is not limited to:</p> <ul style="list-style-type: none"> • Protective eyewear, and hearing protection. • Respirators, protective clothing, and gloves as recommended by the fluid and solvent manufacturer.
	<p>CALIFORNIA PROPOSITION 65</p> <p>This product contains a chemical known to the State of California to cause cancer, birth defects or other reproductive harm. Wash hands after handling.</p>

Component Identification

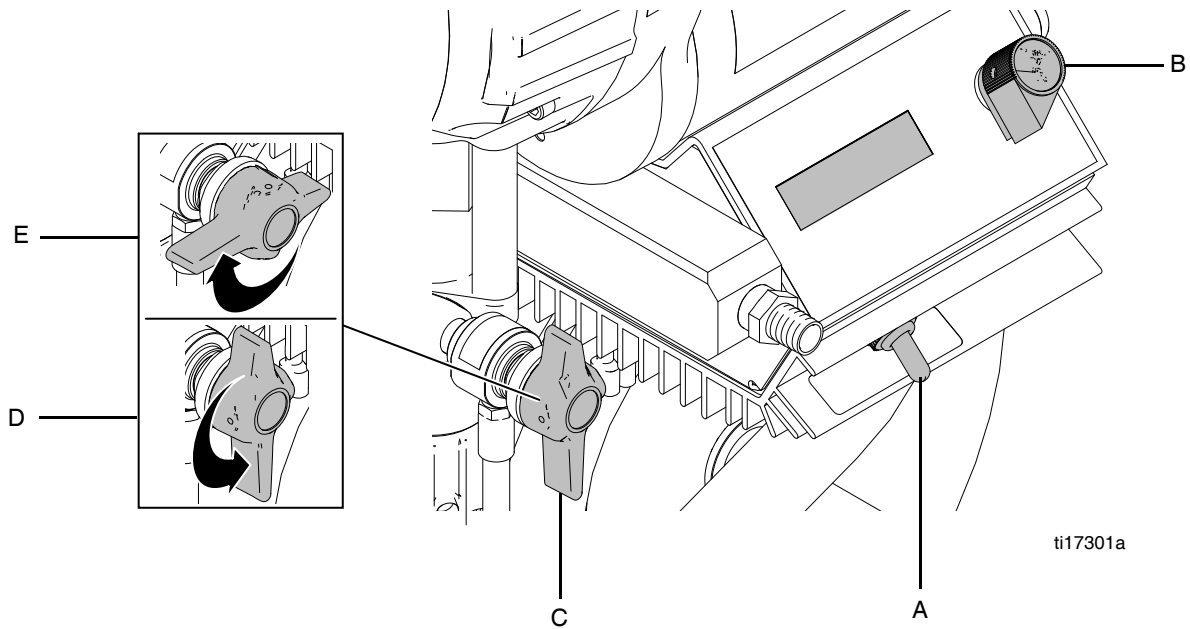

ti17301a

A	Power switch	Turns sprayer ON and OFF
B	Pressure Control Knob	Adjusts pressure. Turn clockwise to increase pressure and counterclockwise to decrease pressure.
C	Prime/Pressure Relief Valve	Primes pump and relieves pressure from gun, hose and tip.
D	Prime/Pressure Relief Valve Open Position	Relieves pressure from gun, hose and tip and primes the unit when in the open position. Valve is in open position when there is a wider gap between valve handle and cam body.
E	Prime/Pressure Relief Valve Closed Position	Refer to Pressure Relief Procedure , page 7 Pressurizes system when closed. Valve is in closed position when there is a slight gap between valve handle and cam body.

Operation

Pressure Relief Procedure

Follow this **Pressure Relief Procedure** whenever you stop spraying and before cleaning, checking, servicing, or transporting equipment.

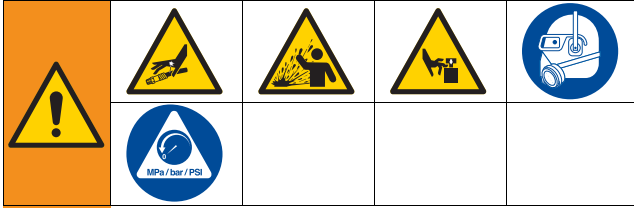

1. Engage the gun trigger lock. Refer to the separate instruction manual provided with gun for safety features and how to engage the trigger lock.
2. Turn the unit off.
3. Disengage the gun trigger lock and trigger the gun to relieve residual fluid pressure.

Hold metal part of the gun in contact with grounded metal pail. Use minimum pressure.

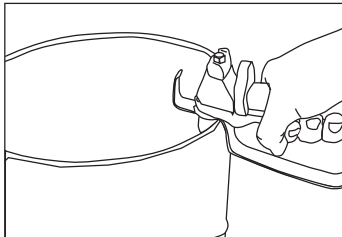

ti15989a

4. Turn Prime/Pressure Relief Valve to the open (priming) position to relieve residual pressure.

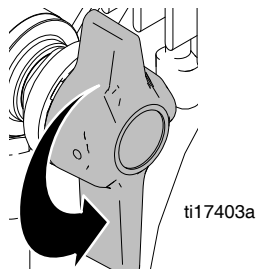

ti17403a

There will be a wider gap between valve handle and cam body when in open position. In the closed position there is only a very slight gap.

The valve handle can move both clockwise and counter clockwise and can face different directions.

5. Re-engage gun trigger lock and close Prime/Pressure Relief Valve. Turn Prime/Pressure Relief Valve to the open (priming) position to relieve residual pressure.

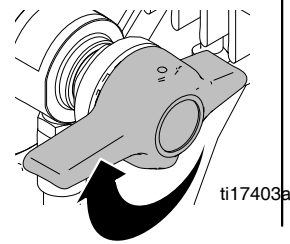

ti17403a

If the **spray tip or hose is clogged**, follow Steps 1 through 5 above. Expect paint to splash into the bucket while relieving pressure during Step 4.

If you suspect that pressure hasn't been relieved due to damaged Prime/Pressure Relief Valve, or other reason, engage the gun trigger lock and then very slowly loosen the tip nut or hose end coupling to relieve pressure gradually, then loosen completely and clear obstruction.

Setup



- To reduce the risk of static sparking, fire or explosion which can result in serious bodily injury and property damage, always ground the sprayer and system components and the object being sprayed, as instructed in the safety warning section of this manual.
- Ensure electrical service is 120 VAC, 15 amp minimum and the outlet is properly grounded.
- For generator power, a minimum 7000 watt generator with a voltage regulation must be used.

Connect the hose and gun

1. Remove the plastic cap plug from the outlet and screw a conductive or grounded 3000 psi spray hose onto fluid outlet.
2. Connect an airless spray gun to the other end of the hose. Do not install spray tip.

Do not use thread sealer on swivel unions as they are made to self seal.

Fill the Packing Nut/Wet Cup

1. Fill the Packing Nut/Wet Cup with 5 drops of Air lessco Throat Seal Oil (TSO).



Flush the Sprayer

1. Flush the sprayer. See **Flushing Procedure**, page 8.

Prime and Flush Storage Fluid

NOTICE

The equipment was tested with lightweight oil, which is left in the fluid passages to protect parts. To avoid contaminating your fluid with oil, flush the equipment with a compatible solvent before using the equipment for the first time.

Before beginning a new spraying project you need to prime the sprayer and flush the storage fluid out of the sprayer.

Oil- or Water-based Materials

- When changing from water-based material to oil based material, flush with soapy water and then mineral spirits.
- When changing from oil based material to water base material, flush with mineral spirits, followed by soapy water, then a clean water flush.
- When flushing with solvents, ground pail and gun.
- Flush before changing colors, before fluid can dry in the equipment, at the end of the day, before storing, and before repairing equipment.

Flushing

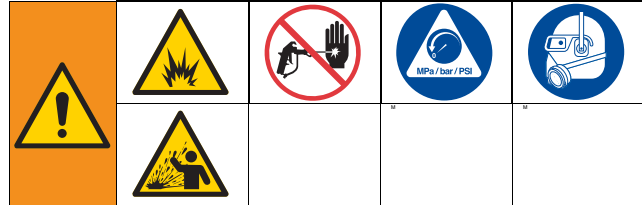

- To reduce the risk of static sparking, which can cause fire or explosion.
- Always hold a metal part of the gun firmly against the metal pail when flushing. This also reduces splashing.
- Always remove the spray tip before flushing.

1. Make sure the gun trigger lock is engaged and there is no spray tip in the gun. Refer to the separate instruction manual provided with gun for safety features and how to engage the trigger lock.

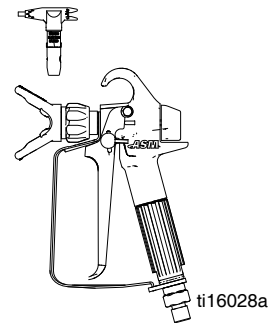

2. Pour enough clean, compatible solvent into a large, empty metal pail to fill the pump and hoses.
3. Place the suction tube into the pail or place the pail under the pump.
4. Turn Pressure Control Knob to low.



- Open the prime/pressure relief valve to the open - "Priming Position". This will allow an easy start.

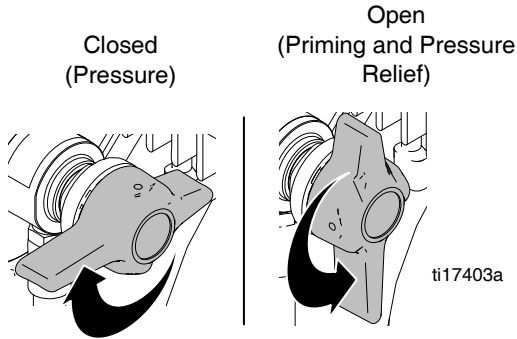

- Turn the unit ON/OFF switch to ON.
- Point the gun into the metal pail and hold a metal part of the gun firmly against the pail. Maintain firm metal to metal contact between gun and container.

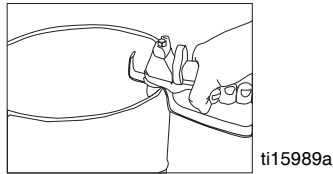

- Disengage the gun trigger lock and squeeze the trigger. At the same time, slowly turn the pressure control knob clockwise, just enough to move liquid at low pressure.
- Allow the pump to operate until clean solvent comes from the gun.
- Release the trigger and engage the gun trigger lock.
- If you are going to start spraying, place the pump or suction tube into the supply container. Release the gun trigger lock and trigger the gun into another empty, metal container, holding a metal part of the gun firmly against the metal pail, forcing the solvent from the pump and hose. When paint starts coming from gun, turn pressure control knob to minimum pressure, place prime/pressure relief valve in prime (open) position and engage the gun trigger lock.
- If you are going to store the sprayer, remove the suction tube or pump from the solvent pail, force the solvent from the pump and hose. Engage the gun trigger lock. See **Storage**, 10.

- Whenever shutting down the sprayer, follow **Pressure Relief Procedure**, page 7.

NOTICE

To prevent damage and freezing during storage, never leave water in the fluid pump



Startup

- Prepare the material according to the material manufacturer's recommendations.
- Place the suction tube into the material container.
- Start the sprayer.
 - Prime/PR Valve must be "OPEN" in the priming position.
 - After ensuring the gun trigger lock is engaged, attach tip and safety guard.
 - Turn the unit ON/OFF switch to the "ON" position.
 - Turn the Pressure Control Knob clockwise to prime the pump.
 - After the pump is primed, turn the Prime/PR Valve to the "CLOSED" position.
 - Turn Pressure Control Knob to the desired spray pressure.
 - Disengage the gun trigger lock to begin spraying.

Clogged Flat Tip

Should the spray tip become clogged, relieve pressure from the hose. See **Pressure Relief**, page 7. Secure gun with trigger lock, take off guard, take out the tip, soak in appropriate solvent and clean with a brush. (Do not use a needle or sharp pointed instrument to clean the tip. The tungsten carbide is brittle and can chip.)

Adjusting the Pressure

				
<ul style="list-style-type: none"> To reduce the risk of injection, never hold your hand, body, fingers or hand in a rag in front of the spray tip when cleaning or checking for a cleared tip. Always point the gun toward the ground or into a waste container when checking to see if the tip is cleared or when using a self cleaning tip. When you spray into the paint bucket, always use the lowest spray pressure and maintain firm metal to metal contact between the gun and container. To stop the unit in an emergency, turn the engine off. Then relieve the fluid pressure in the pump and hose. See Pressure Relief Procedure, page 7. 				

When adjusting the pressure, turn the Pressure Control Knob clockwise to increase pressure and counterclockwise to decrease pressure. Always use the lowest pressure necessary to completely atomize the material. If more coverage is needed, use a larger tip rather than increasing the pressure.

Operating the sprayer at higher pressure than needed wastes material, causes early tip wear, and shortens sprayer life.

Check the spray pattern. The tip size and angle determines the pattern width and flow rate.

Shutdown

1. **Relieve Pressure**, page 7.
2. Clean the tip and gun as recommended in the separate Gun Manual supplied with the gun.
3. If spraying water-based material or a material that could harden in the sprayer overnight, flush the sprayer after use. See **Flushing**, page 8.

Storage

Short Term

1. Flush sprayer with compatible solvent before storing, then fill the pump and hoses with an oil based solvent such as mineral spirits or Airlessco Pump Conditioner.
 - For oil base paint: flush with mineral spirits
 - For water-base paint: flush with water, then mineral spirits and leave the pump, hose and gun filled with mineral spirits.

Long Term

For longer storage, use Airlessco Pump Conditioner. Shut off sprayer, **Relieve Pressure**, page 7, and make sure prime/pressure relief valve is left open.

Start Up After Storage

Before using water-base paint, flush sprayer with soapy water and then a clean water flush. When using oil-base paint, flush out the mineral spirits with the material to be sprayed.

Always store unit indoors.

Maintenance

Daily Maintenance

1. Keep the displacement pump packing nut/wet cup lubricated with Airlessco TSO (Throat Seal Oil) at all times. The TSO helps protect the rod and packings.
2. Inspect the packing nut daily. If seepage of paint into the packing nut and/or movement of the piston upward is found (while not spraying), the packing nut should be tightened just enough to stop leakage (torque is 24 in-lbs). Overtightening will damage the packings and reduce the packing life.

Electric Motor Maintenance

Lubrication

The motor is supplied with pre-lubricated ball bearings, lubricated for the life of the bearing.

Motor Brushes

Motor brushes need periodic inspection and replacement as wear indicates. Standard brushes have an initial length of 1" and should be replaced when they are worn to a length of 1/2". Brush wear is greatly influenced by individual application and it is recommended that brush wear be checked at early intervals of operation in order to determine future required inspection.

To change the brushes:

1. Unplug the machine.
2. Open the two covers at the rear of the motor.
3. Push the brush retainer clip in and withdraw.
4. Disconnect the brush wire.
5. Pull out the wire.
6. Remove the worn brushes.
7. Install new brushes in the reverse order.

To increase brush life, new brushes (Part #331780 for 110 volt) need to have a run in period. After changing brushes, set the machine for spraying. With a bucket of Pump Conditioner and water, a 50' 1/4" airless hose, airless gun and tip on unit, open the prime/pressure relief valve and switch on. The pump will now prime. With pump running in the prime mode, turn the pressure control knob to high pressure. (The pump has to cycle fast with no pressure in the pump). Run the pump for 20 minutes and the brushes will be run in.

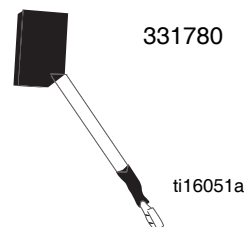

Servicing the Fluid Pump



Fluid Pump Disconnect

1. **Relieve Pressure**, page 7.
2. Flush the material you are spraying out of the machine.
3. Remove the rigid fluid tube (16).
4. Remove the connecting rod shield(12).
5. Move the piston rod (10) to its lowest position by cycling pump slowly.
6. Turn off the motor and disconnect power from unit.
7. Disconnect fluid tube (16) from pump body.
8. Remove the retaining ring (4) from the connecting rod (2) and slide the sleeve (3) down revealing the connecting rod pin (1).
9. Using a 1/2" wrench, unscrew the two bolts (8) from the cover assembly (14). The fluid pump (9) will be hanging loosely at this point.
10. Remove the connecting rod pin (1) out of the connecting rod (2), allowing the removal of the fluid pump (9) from the machine.

Fluid Pump Reinstall

1. Loosen the packing nut and ensure that the piston rod (10) is in its upper position in the fluid pump body, snap cap onto packing nut and slip the sleeve (3) and the retaining ring (4) over the piston rod (10).
2. Push the piston rod (10) up into the connecting rod (2) and align the holes. Insert the connecting rod pin (1) through the connecting rod (2) and piston. Slip the sleeve (3) up over the connecting rod pin (1) and insert the retaining ring (4) into the groove on the connecting rod (2).
3. Push the two bolts (8) through the tube spacers (11) and screw them into the cover assembly. Using a 1/2" wrench, tighten the two bolts (8) evenly (alternating between them) until you reach 30 ft-lbs.
4. Reassemble lower suction valve assembly by placing the suction seat, O-ring, suction ball and suction ball guide in the suction nut (7) and screw onto fluid pump body.
5. Reconnect the fluid tube (16) to the fluid pump body.
6. Start the machine and operate slowly to check the piston rod (10) for binding. Adjust the two bolts (8), holding the fluid pump body to the cover assembly, if necessary. This will eliminate any binding.
7. Tighten packing nut clockwise until resistance is felt against the Belleville Springs, go 3/4 of a turn more. Put five drops of Airlessco Throat Seal Oil in the packing nut.
8. Run the machine at full pressure for several minutes. Release the pressure by following the **Pressure Relief Procedure**, page 7, and readjust the packing nut per step 7 above.
9. Install the connection rod shield (12) so the small hole is in the upper right hand corner.

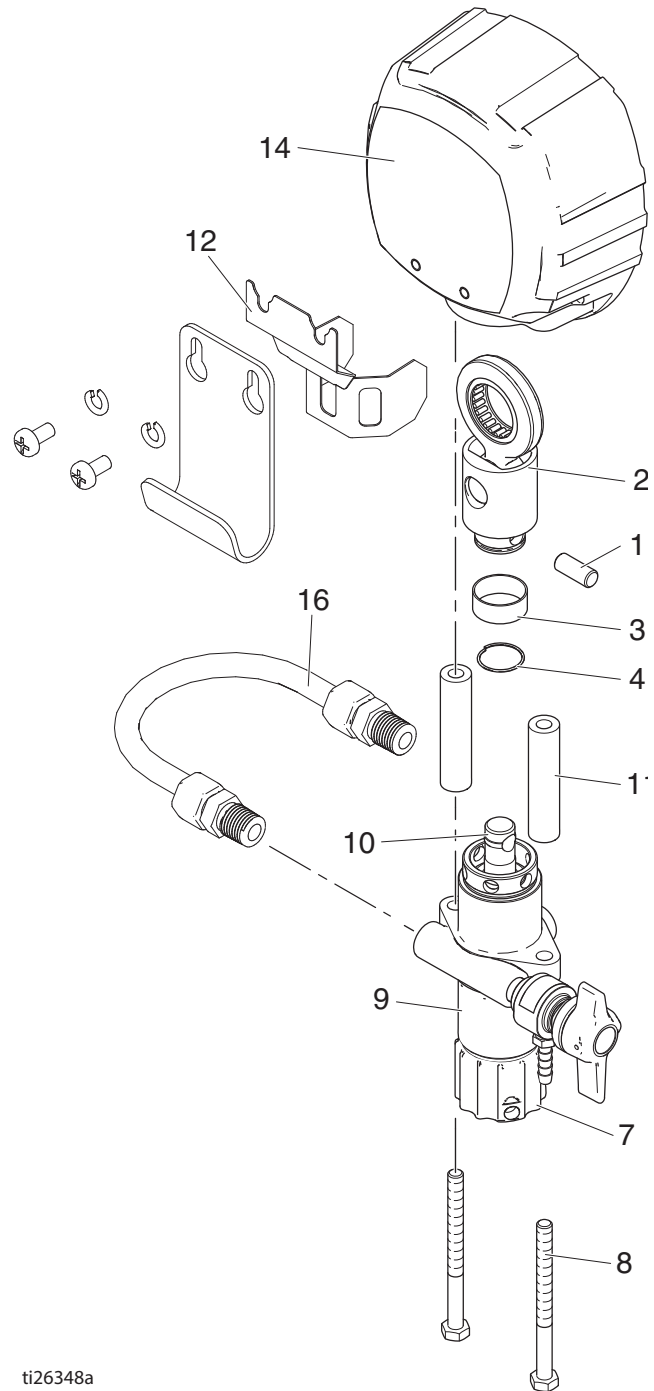

ti26348a

Servicing the Inlet Valve

1. Un-thread and remove suction nut from the fluid pump body (8).
2. Remove suction seat (12), O-ring (11), suction ball (10) and ball guide (9).
3. Clean all parts and inspect them for wear or damage, replacing parts as needed.
4. Clean inside of the fluid pump body (8).
5. Reassemble lower suction valve assembly by placing the suction seat (12), O-ring (11), suction ball (10) and suction ball guide (9) in the suction nut (13) and screw onto fluid pump body (8).

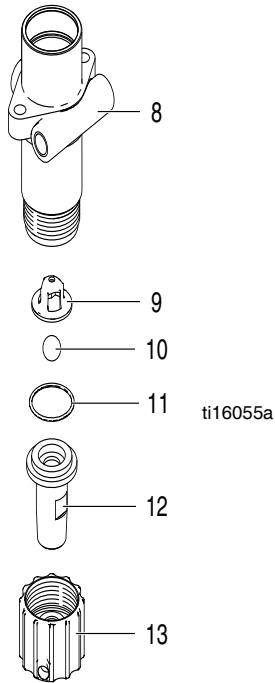

Packing Replacement Procedures

Disassembly of the Fluid Pump

1. **Disconnect the Fluid Pump**, page 11.
2. Unscrew and remove the packing nut, with wet cup cap.
3. Push the piston rod down through the packings and out of the pump.
4. Now push the packing removal tool up through the pump and remove from the top bringing packings, spacer and springs along with it, leaving fluid body empty.
Make sure all old packings and glands have been removed from fluid pump.
5. Clean inside of fluid body.
6. Disassemble all parts and clean for reassembly. Discard any old packings.
7. Lubricate leather packing in lightweight oil for 10 minutes prior to reassembly.

Reassembly of the Fluid Pump

1. Place lower male gland(1) down on the flat side.
2. Take three of the lower polyethylene packings (2) and two of the leather packings (23) and place onto the male gland (1), with the inverted side down, in the following order:
 - Polyethylene
 - Leather
 - Polyethylene
 - Leather
 - Polyethylene
3. Take the female adaptor (3), which is inverted on both sides, and place it on top of your assembled lower packings.
4. Follow step 2 with your packings inverted side up.
5. Take the second lower male gland (1) and place it on top of your assembled packings with rounded side down.
6. Take assembled glands and packings (13 pieces) and slide onto the lower half of the piston (14).
7. Take the spacer (15) and slide over the top of the piston (14).
8. Take three spring washers (16) and slide over the top of the piston (14) in the following order:
 - First spring - curve facing up
 - Second spring - curve facing down
 - Third spring - curve facing up
9. Take the upper male gland (17) and place it rounded side up.

10. Take three upper polyethylene packings (18) and two leather packings (22) and assemble with inverted side down, on to the male gland (17) in the following order:

- Polyethylene
- Leather
- Polyethylene
- Leather
- Polyethylene

11. Take upper female gland (19) and place on top of assembled upper packings with the inverted side down.

12. Take assembled upper glands and packings (7 pieces) and slide on over the top of the piston (14), making sure inverted sides are down.

13. Take the packing holder (20) and replace the white O-ring (24) and the black O-ring (25) with new ones from the packing kit.

14. Slide the packing holder (20) over the top of the upper packings so they fit inside.

15. Lubricate inside of the fluid pump body (4) and the outside of the packings with a light weight oil.

16. Slide assembly into fluid pump body.

To keep packings secured in correct position, hold the pump body upside down and push the completed assembly upwards into the pump body. Once placed inside, tilt pump body back up to keep all pieces in.

17. Tighten packing nut (21) onto the top of the fluid pump body and tighten until you feel slight resistance against the Belleville Springs (16). Using the Packing Adjustment Tool, tighten another 3/4 of a turn.

18. Reinstall Fluid Pump, page 12.

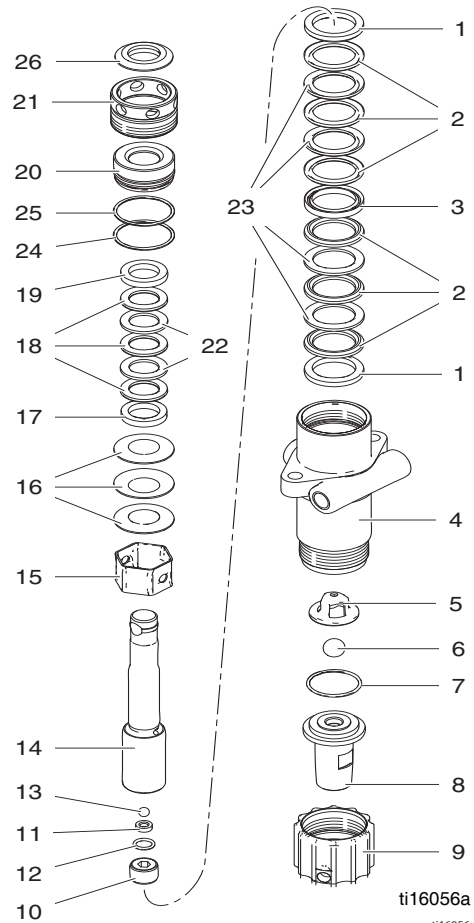

Gear and Pump Assembly

Servicing Gear box Assembly

1. Remove fluid pump. See **Fluid Pump Disconnect**, page 11.
2. Remove frame from the gearbox by loosening the four mounting screws.
3. Separate cover assembly (14) from box by removing bolts (1) from front of cover and back of box and shoulder bolts (2) from front of cover and back of box.
4. Lay unit on its back and disassemble gearbox.
5. Inspect bearings (15, 18), Crosshead Assembly (16), Gearcrank (17) and sleeve bearing (10) inside cover assembly (14) for wear/damage. Replace worn/damaged parts.

6. If gear grease needs replacing, replace with gear grease (Part No. 114819).
7. Clean mating surfaces of cover and box thoroughly. use Part No. 342899 Instant Gasket.
8. Reassemble in reverse order.

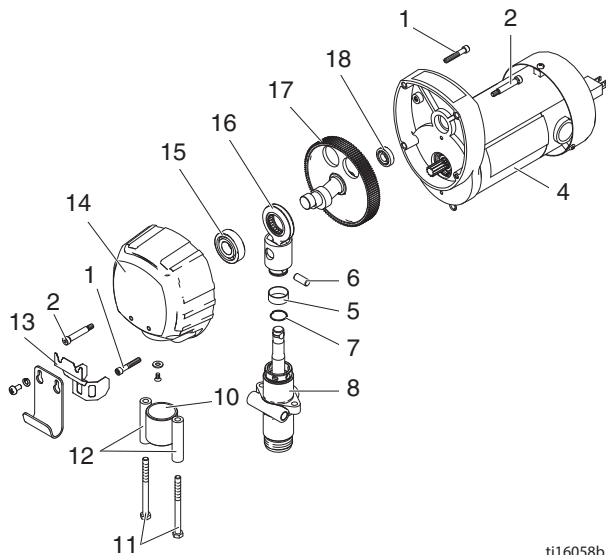

NOTE: Ensure ground lead (A) is connected to bolt below control board.

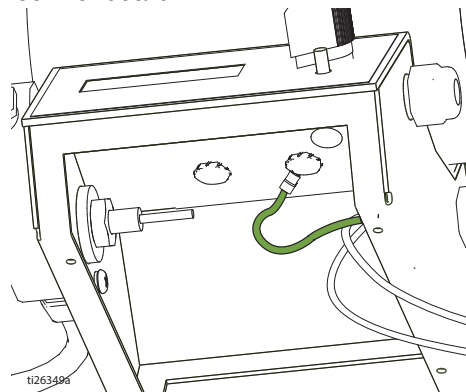

NOTICE

Unit will not operate if wires are disconnected or pinched. Upon reassembly, ensure all wires are connected and not pinched.

Sensor

1. Remove the four screws, heatsink, and lower the pressure control assembly.
2. Disconnect sensor lead from the board.
3. Unscrew sensor by holding sensor with 3/4" wrench.
4. Reassemble in reverse order. Torque to 30 ft-lbs.

NOTICE

Unit will not operate if wires are disconnected or pinched. Upon reassembly, ensure all wires are connected and not pinched.

Replacement of Electrical Components

To avoid electric shock, always unplug the electrical cord before servicing the machine.			

Anytime the pressure control assembly, sensor, or both are replaced, perform the calibrations.

Pressure Control Assembly (Electrical Control Board)

1. Unplug machine's power cord.
2. Remove six screws heatsink housing.
3. Disconnect all leads from pressure control assembly.
4. Reassemble in reverse order
5. Torque to 30 ft-lbs.

Potentiometer

1. Lower pressure control assembly as described above.
2. Disconnect potentiometer lead from pressure control assembly.
3. Use a 1/16" allen wrench, loosen set screw in the potentiometer knob and remove knob and spacer.
4. Using a 1/2" wrench or deep socket, remove the nut from the potentiometer shaft assembly.
5. Pull entire potentiometer assembly out of the terminal box.
6. Replace in reverse order.

NOTICE

Unit will not operate if wires are disconnected or pinched. Upon reassembly, ensure all wires are connected and not pinched.

On-Off Toggle Switch

1. Lower the pressure control assembly as described above.
2. Disconnect the two wires on the toggle switch.
3. Use a 9/16" wrench to loosen the nut on the toggle switch shaft.
4. Reassemble in reverse order.

NOTICE

Unit will not operate if wires are disconnected or pinched. Upon reassembly, ensure all wires are connected and not pinched.

Liquid Crystal Display (LCD)

1. Lower pressure control assembly as described above.
2. Unscrew the two nuts (M3) and remove LCD Display assembly.
3. If unable to loosen the two nuts, hold them and unscrew the two screws. Then remove the LCD Display Assembly.
4. Reassemble in reverse order, while making sure that the two spacers and the two washers are in place. Tighten the two nuts handtight and seal with blue loctite. **Do not** overtighten the nuts as this will damage the display.

NOTICE

Unit will not operate if wires are disconnected or pinched. Upon reassembly, ensure all wires are connected and not pinched.

Troubleshooting





General		
Problem	Cause	Solution
Unit doesn't prime	Airleak due to loose suction nut	Tighten suction nut.
	Airleak due to worn o-rings	Replace o-ring (108526) on suction seat and o-ring (867370) below suction seat.
	Airleak due to hole in suction hose	Replace suction hose.
	Stuck or fouled balls	Service inlet and outlet valves.
Unit primes but has poor or no pressure	Pressure set too low	Turn up pressure.
	Filter(s) are clogged	Clean or replace gun filter, inlet filter, and/or manifold filter.
	Outlet valve fouled/worn.	Service outlet valve.
	Prime/pressure relief valve bypassing	Clean or replace prime/pressure relief valve (866428).
	Packings and/or piston worn	Tighten packing nut, repack unit.
Unit does not maintain good spraying pressure	Blown spray tip	Replace spray tip.
	Packings and/or pistons worn	Repack unit.
	Upper seat worn	Replace upper seat.
Unit does not run	Tripped Breaker	Reset breaker
	Electrical Failure	See Machine Does Not Start

Electrical		
Problem	Cause	Solution
Machine does not start	Control Settings	Make sure machine is plugged into the wall. Verify the on-off switch is in the ON position and the pressure control knob is turned all the way to the right (clockwise for maximum pressure).
	Thermal Breaker	Use multi-meter to test the breaker for continuity or replace with a new breaker. If breaker reads good, see Power Source .
	Pressure Control Assembly (Board)	If the power indicating light is still out after checking the control settings and power source, replace the pressure control assembly.

Problem	Cause	Solution
	Motor	<p>Remove the motor brush covers and turn the machine ON. Set the potentiometer (POT) at maximum pressure and check for DC voltage across both brush terminals. It should read greater than 80 volts DC.</p> <p>If you have DC voltage, turn the machine off and unplug it from the wall. Check to make sure the brushes are making good contact with the armature. Replace the brushes if they are less than 1/2" long. If the brushes are good, replace the motor.</p> <p>If you do not have DC voltage, see Sensor.</p>
	Sensor	<p>Plug another sensor board into the board and perform the zero calibration procedure. If the machine starts to run, the sensor is bad. If there is no replacement sensor available, use a multi-meter to test the resistance across the red and black wires of the sensor (be sure to test the plug). You should read 1.5 - 3.5k ohms. A faulty sensor usually reads no continuity (open).</p> <p>If the sensor passes all the tests, see Pressure Control Knob (Potentiometer).</p>
	Pressure Control Knob (Potentiometer)	<p>Plug another potentiometer (POT) into the control board. If the machine starts, the old POT is bad.</p> <p>When a replacement POT is not available, remove the POT lead (with the machine turned off) from the control board and test the resistance between the red and black wires (be sure to test at the plug). The resistance should read between 8-12k ohms. If it is outside of this range replace the POT.</p> <p>If there is DC voltage at the motor brushes and the sensor and pressure control knob are functioning, replace the pressure control assembly.</p>

Pressure Control Repair

Motor Control Board Diagnostics

				
Relieve pressure and unplug sprayer before servicing control board. See Pressure Relief Procedure , page 7.				



Keep a new transducer on hand to use for test.

NOTICE
Do not allow sprayer to develop fluid pressure with out transducer installed. Leave prime/pressure relief valve open if test transducer is used.

1. For sprayers with digital display, see **Digital Display Messages**, page 20
2. Remove screws and cover.
3. Turn ON/OFF switch ON.
4. Observe LED operation and reference following table:

LED BLINKS	SPRAYER OPERATION	INDICATES	WHAT TO DO
Once	Sprayer runs	Normal operation	Do nothing
Two times repeatedly	Sprayer shuts down and LED continues to blink two times repeatedly	Run away pressure. Pressure greater than 4500 psi (310 bar, 31 MPa) or damaged pressure transducer.	Replace motor control board or pressure transducer.
Three times repeatedly	Sprayer shuts down and LED continues to blink four times repeatedly.	Pressure transducer is faulty or missing	Check transducer connection. Open prime/pressure relief valve. Substitute new transducer for transducer in sprayer. If sprayer runs, replace transducer.
Four times repeatedly	Sprayer shuts down and LED continues to blink four times repeatedly.	Line voltage is too high	Check for voltage supply problems
Five times repeatedly	Sprayer does not start or shuts down and LED continues to blink five times repeatedly	Motor fault	Check for locked rotor, shorted wiring or disconnected motor. Repair or replace failed parts.
Six times repeatedly	Sprayer shuts down and LED blinks six times repeatedly	Motor is too hot or there is a fault in the motor thermal device	Allow sprayer to cool. If sprayer runs correctly when cool, check motor fan function and air flow. Keep sprayer in cool location. If sprayer does not run when cool and continues to blink 6 times, replace motor.
Eight times repeatedly	Sprayer stops or does not run	High input voltage	Check power source for correct voltage

Digital Display Messages

				
<p>No display does not mean that sprayer is not pressurized. Relieve pressure before repair. See Pressure Relief Procedure, page 7</p>				

DISPLAY	SPRAYER OPERATION	INDICATION	ACTION
No Display	Sprayer stops. Power is not applied. Sprayer may be pressurized.	Loss of power.	Check power source. Relieve pressure before repair or disassembly.
3000 psi 210 bar 21 Mpa	Sprayer is pressurized. Power is applied. (Pressure varies with tip size and pressure control setting.)	Normal operation	Spray
E=02	Sprayer may continue to run. Power is applied.	Pressure greater than 4500 psi (310 bar, 31 MPa) or pressure transducer faulty	Replace pressure control board or pressure transducer
E=03	Sprayer stops. Power is applied.	Pressure transducer faulty, bad connection or broken wire.	Check transducer connection. Open prime/pressure relief valve. Substitute new transducer for transducer in sprayer. If sprayer runs, replace transducer.
E=04	Sprayer stops. Power is applied.	Line voltage too high.	Check for voltage supply problem
E=05	Sprayer does not start or stops. Power is applied.	Motor fault	Check for locked rotor, shorted wiring or disconnected motor. Repair or replace failed parts.
E=06	Sprayer stops. Power is applied.	Motor is too hot.	Allow sprayer to cool. If sprayer runs correctly when cool, check motor fan function and air flow. Keep sprayer in cool location. If sprayer does not run when cool and continues to blink 6 times, replace motor.
----	Power is applied.	Pressure less than 200 psi (14 bar, 1.4 MPa)	Increase pressure if desired. Prime/pressure relief valve may be open.
E=08	Sprayer stops or does not start	High input voltage	Check power source for correct voltage

Airless Spray Gun		
Problem	Cause	Solution
Coarse spray	Low pressure	Increase the pressure
Excessive fogging (overspray)	High pressure	Reduce the pressure to satisfactory pattern distribution.
	Material too thin	Use less thinner
Pattern too wide	Spray angle too large	Use smaller spray angle tip
Pattern too narrow	Spray angle too small	Use larger spray angle tip (if coverage is OK, try tip in same tip group)
Too much material	Tip too large	Use smaller tip
	Material too thin	Use smaller tip
	Pressure too high	Reduce pressure
Too little material	Tip too small	Use next larger tip Material too thick
Thin distribution in center of pattern "horns"	Worn tip	Change to new tip
	Wrong tip	Use tip with narrow spray angle
Thick skin on work	Material too viscous	Thin cautiously
	Application too heavy	Reduce pressure and/or use tip in next smaller tip size
Coating fails to close and smooth over	Material too viscous	Thin cautiously
Spray pattern irregular, deflected	Orifice clogged	Clean carefully
	Tip damaged	Replace with new tip
Craters or pock marks, bubbles on work	Solvent balance	Use 1 to 3% "short solvents remainder "long" solvents (this is most likely to happen with material of low viscosity, lacquers, etc.)
Clogged screens	Extraneous material in paint	Clean screen
	Course pigments	Use coarse screen if orifice size allows.
	Poorly milled pigments (paint pigments glocculate)	Use courser screen, larger orifice tips. Obtain ball milled paint. If thinner had been added, test to see if a cover screen. Incompatible drop placed on top of paint mixes or flattens out on the paint mixture and thinners on the surface. If not, try different thinner in fresh batch of paint.
Excess paint builds on tip guard	Spray gun too close to surface	Hold gun further from surface sprayed
	Pressure setting too high	Reduce pressure setting
Drips, spits from tip	Valve seat and/or ball in gun head damaged or worn	Service spray gun, replace valve assembly
Tip clogs continually	Debris in paint	Thoroughly strain the paint before use
	Gun filter missing	Do not operate without inlet strainer
	Coarse filter mesh	Do not operate without inlet strainer

Parts

Optional Manifold Filter (866480)

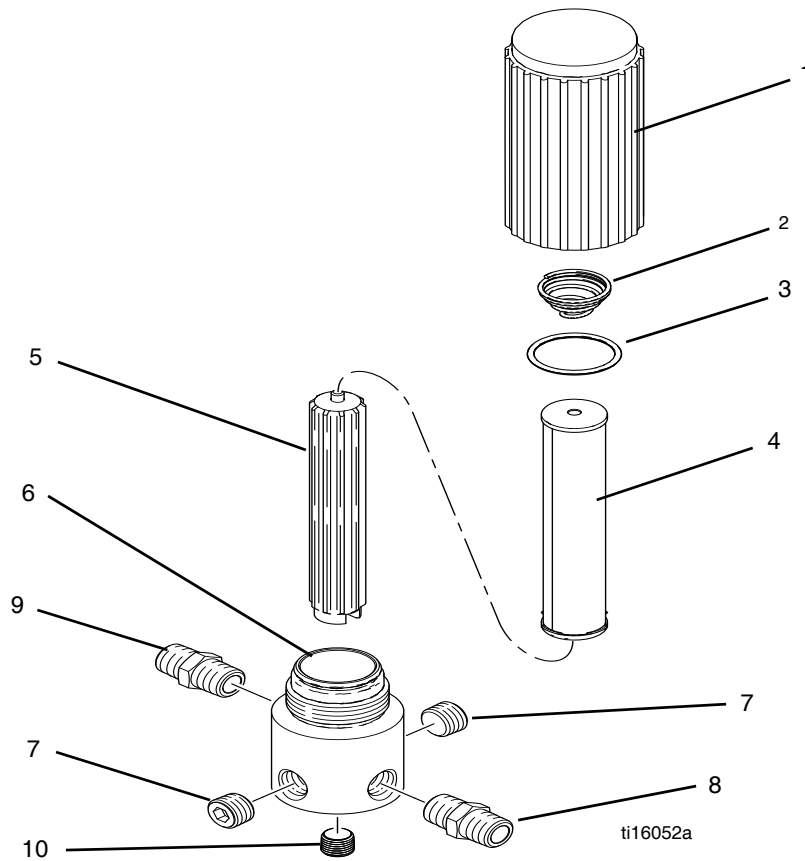

Ref.	Part	Description	Qty	Ref.	Part	Description	Qty
1	867145	COVER	1	6	867077	BASE	1
2	301356	SPRING	1	7	867420	PLUG	2
3	867377	O-RING	1	9	867309	NIPPLE 3/8\"M x 1/4\"M	1
4	867214	FILTER 60 MESH	1	10	557391	PLUG 1/4\"	1
5	867647	SUPPORT	1				

Inlet Valve

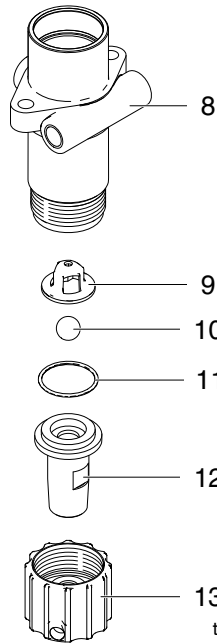

Ref.	Part	Description	Qty
8	331011	FLUID PUMP BODY	1
9	331029	SUCTION BALL GUIDE	1
10	331030	SUCTION BALL	1
11	108526	O-RING	1
12	331292	SUCTION SEAT (HI-BOY)	1
13	331034	SUCTION NUT	1

ti16055a

Piston Assembly (331093)

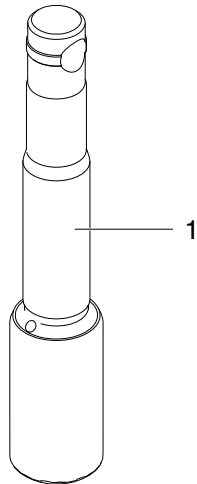

Ref.	Part	Description	Qty
1		PISTON	1
4		OUTLET BALL	1
5		O-RING	1
6		OUTLET SEAT	1
7		OUTLET SEAT RETAINER	1
8		PIN, SPRING COILED	1

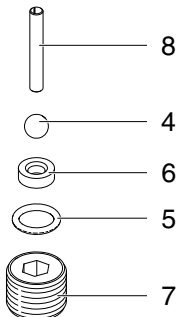

ti17684a

Frame Parts Diagram

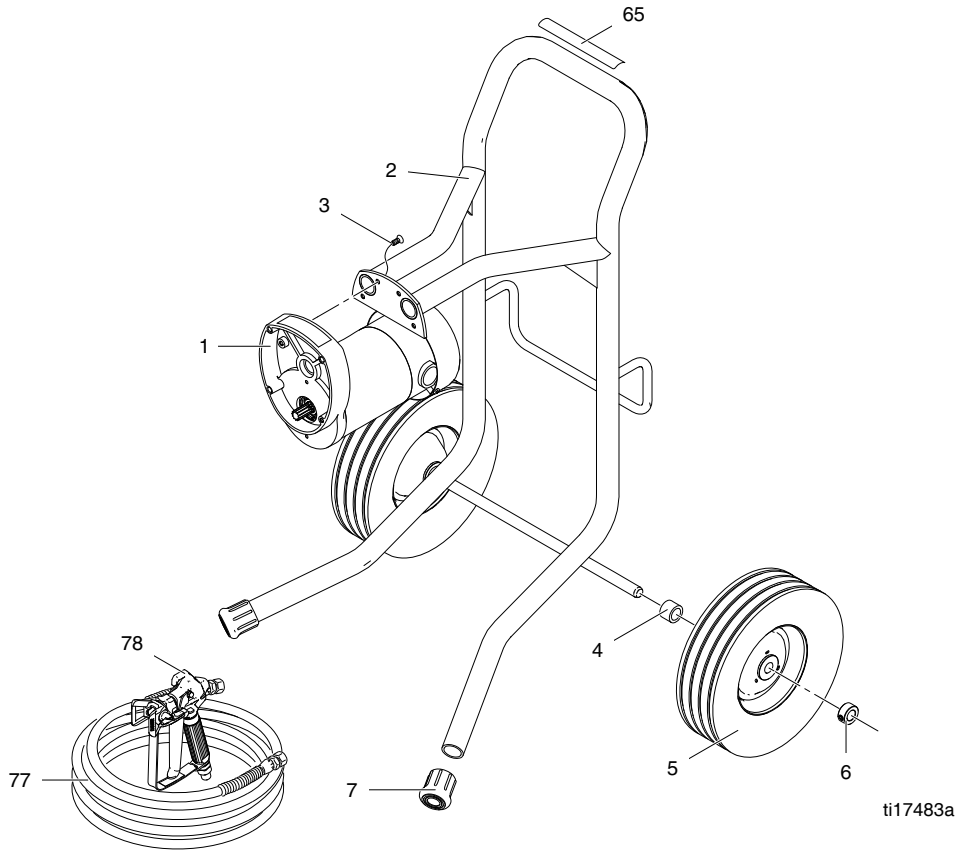

Ref. Part	Description	Qty	Ref. Part	Description	Qty
1	331491 MOTOR,1HP, 90 VDC, 2500RPM	1	6	143029 COLLAR,SCREW,SET	2
2	331273 FRAME,LP540 HD	1	7	331048 BOOT,RUBBER BOOT	2
3	16F551 FASTENER,THREAD,EXTERNAL	4	65	342446 LABEL CLEANING-WARNING	1
4	866356 SPACER,SPACER .75 LG PVC	2	77	865674 HOSE,PAINT HOSE 1/4X50'	1
5	106062 WHEEL,SEMI PNEUMATIC	2	78	24E513 GUN,SPRAY, 009 (HOME DEPOT)	1

Control Parts Diagram

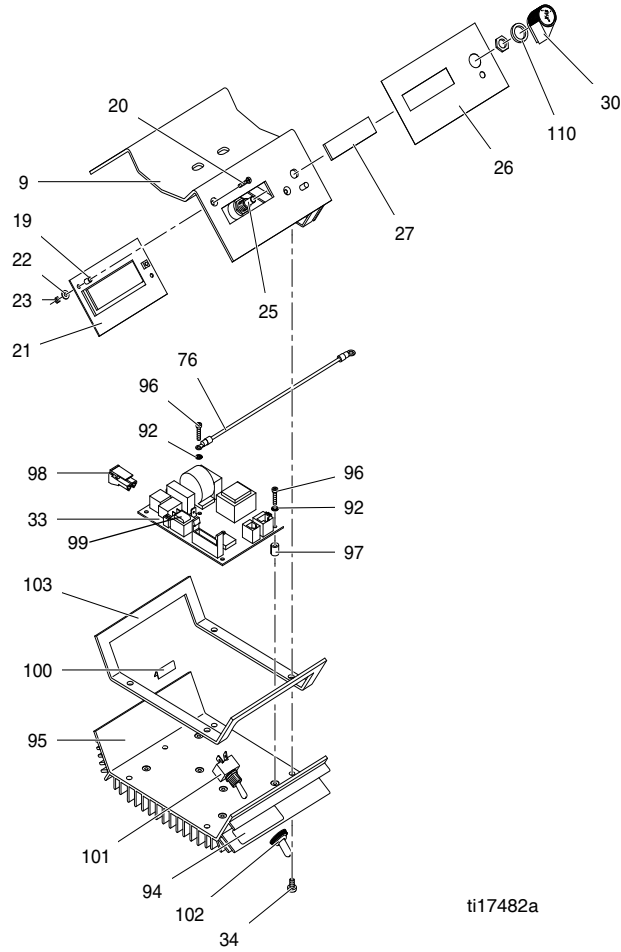

ti17482a

Ref.	Part	Description	Qty	Ref.	Part	Description	Qty
9	867800	TERMINAL BOX WELDMENT	1	94	342513	LABEL OFF-ON	1
19	117281	SPACER,#6 X .312	2	95*		HEAT SINK,MACHINED LP	1
20	867816	SCREW,MACH,PHILLIPS FLAT HD	2	96*		SCREW,MACH,PHILLIPS PAN HD	6
21	867821	DISPLAY,LCD	1	97*		SPACER,CONTROL BOARD	6
22	867731	WASHER,PLAIN-1/8IN.IDX5/16IN. OD	2	98*		CONNECTOR,ELECTRICAL MOTOR	1
23	867817	NUT,HEX	2	99*	867812	MOTOR CONNECTOR	1
25	256219	POTENTIOMETR,ASSEMBLY	1	100		GUARD,SPLASH	2
26	867804	LABEL,CONTROL,LP	1	101*	301083	SWITCH,TOGGLE	1
27	867798	DISPLAY,WINDOW	1	102*	301150	BOOT,RUBBER,BLACK	1
30	116167	KNOB,POTENTIMETER	1	103*	867797	GASKET,COVER LP	1
33*	867965	CONTROL,BOARD,120V	1	110	15C973	GASKET,	1
34	331342	SCREW,MACH,PANHEAD	4				
76	866049	CABLE,ASSY 9" LG	1				
92*		WASHER,LOCK	6				

* Included in 867822 Control Board Kit

Motor and Drive Parts Diagram

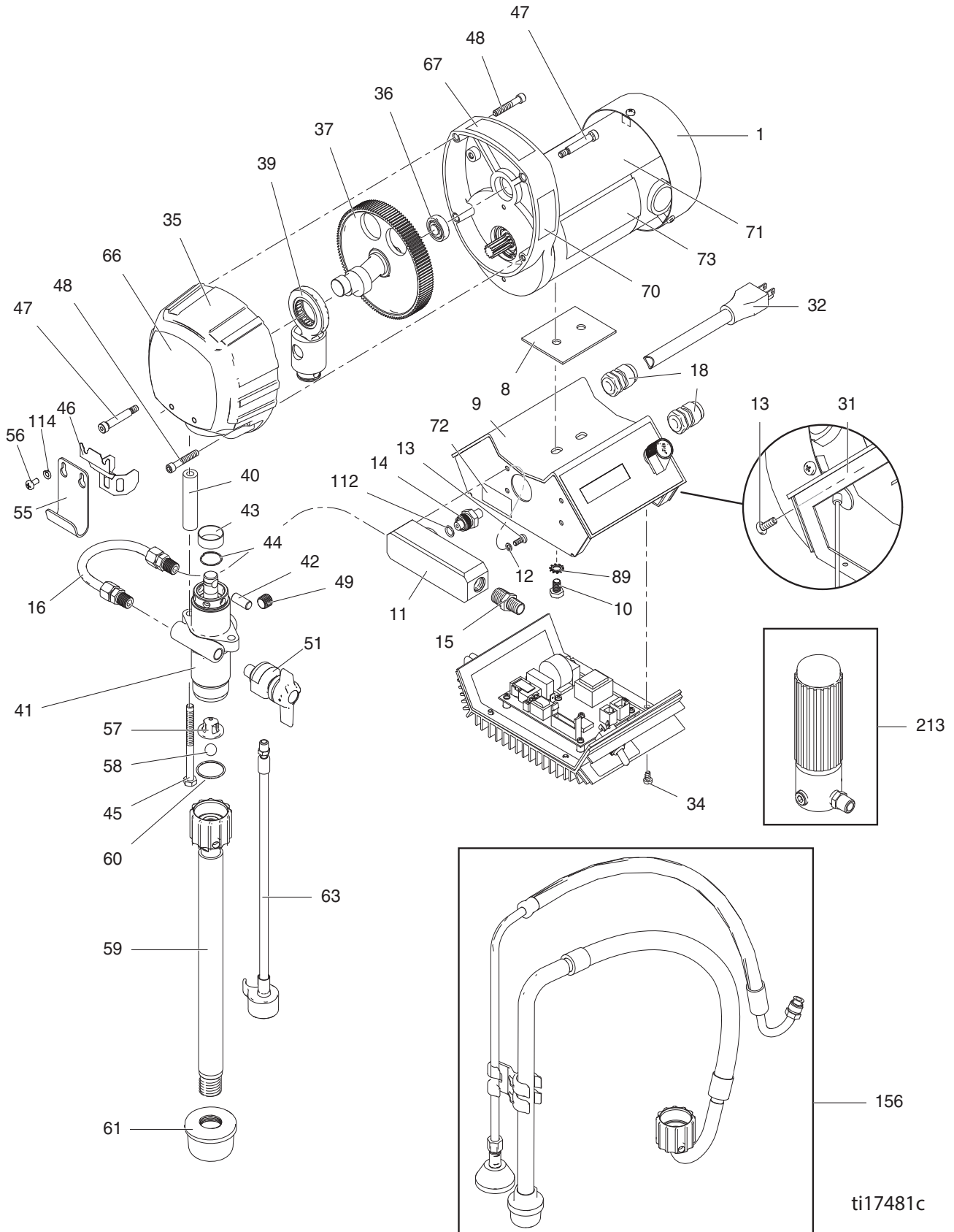

Motor and Drive Parts List

Ref. Part	Description	Qty	Ref. Part	Description	Qty
1	331491 MOTOR,1HP, 90 VDC, 2500RPM	1	51	866428 PRESSURE RELIEF VALVE	1
8	867243 GASKET,SEAL	1	55	331336 HOOK,PAIL	1
9	867800 BOX,TERMINAL BOX WELDMENT	1	56	113783 SCREW,MACH,PNH	2
10	15V909 SCREW,M8X12	2	57	331029 RETAINER,PUMP	1
11	867813 MANIFOLD,	1	58	331030 BALL,BALL .500 GR100 ...SS 440	1
12	100020 WASHER,LOCK	4	59	866479 TUBE,SUCTION,SUBASSEMBLY	1
13	331342 SCREW,10-24 X.50 PH PN HD	5	60	108526 PACKING,O-RING	1
14	243222 TRANSDUCER,PRESSURE CON TROL	1	61	187190 STRAINER	1
15	867309 FITTING,NIPPLE 3/8NPT TO 1/4 NPT	1	63	301348 HOSE,HOSE 1/4 ID X 3/8 OD POLY	1
16❖	331364 TUBE, ASSY 3-1/4"	1	66	342467 LABEL,LABEL FRONT LP AIR LESSCO	1
	867892 TUBE, ASSY 2-1/4"	1	67	342558 LABEL TOOL RENTAL 1X5.5	1
18	331185 VALVE,STRAIN RELIEF	2	70	342524 LABEL- PRIME/SPRAY	1
31	116969 NUT. LOCK	1	71	342561 LABEL TOP (MOTOR) LP540	1
32	331163 CORD,POWER, USA ASSY	1	72	195793▲ LABEL, WARNINGS	1
34	331342 SCREW,MACH,PANHEAD	4	89	17M047 WASHER, lock	2
35	866477 COVER,FRONT,ASSEMBLY (Includes 35a, 35b, 35c)	1	112	111457 O-RING	1
35a	331061 SLEEVE BEARING (not shown)	1	114	C19209 WASHER, lock	2
35b	331234 COVER, BARE (not shown)	1	156	865717 HOSE,SUC TION,BYPASS,LB,SUBASSY	1
35c	331046 BEARING (not shown)	1		342473▲ LABEL GENERAL WARNING (not shown)	
36	331047 BEARING,BALL	1			
37	331593 GEAR,CRANK .29 ASSEMBLY	1			
39	331038 YOKE,CROSSHEAD ASSY	1			
40	331074 SPACER,SPACER 2.691 LONG	2			
41	866482 PUMP,PAINT,ASSY (includes 41a)	1			
41a	331093 PISTON ASSEMBLY	1			
42	866082 PIN,CROSS PIN .375	1			
43	331117 SLEEVE,	1			
44	331062 SPRING,RET. SPRING	1			
45	867539 SCREW,5/16-18 X3.75 HX HD	2			
46	868016 COVER,COVER - GUARD	1			
49	557391 PLUG	1			

▲ Additional warning labels are available at no cost.

+ Motor Brush Kit - 331780

❖ Older machines use tube with approximately 2-1/4" center to center distance. Newer machines use wider spaced tube with approximately 3-1/4" center to center distance. Measure connection points to order correct part.

Packing Replacement

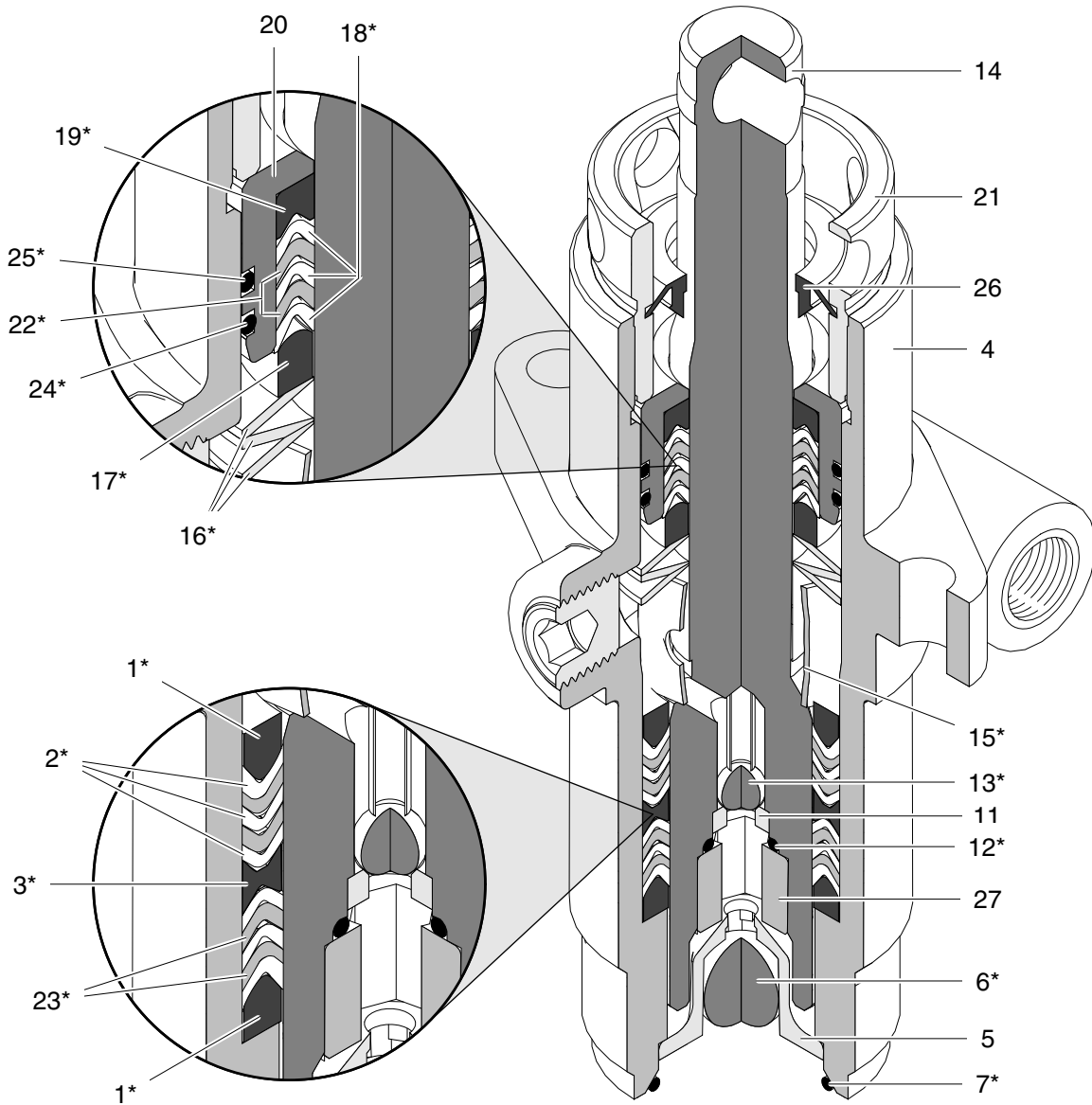

ti16057a

Packing Replacement

Ref.	Part	Description	Qty
1*	331014	MALE GLAND	2
2*	331016	PACKING POLYETHYLENE	6
3*	331308	FEMALE ADAPTOR	1
4	331011	FLUID PUMP BODY	1
5	331029	SUCTION BALL GUIDE	1
6*	331030	SUCTION BALL	1
7*	108526	O-RING	1
8	331292	SUCTION SEAT (HI-BOY)	1
9	331034	SUCTION NUT	1
10+	331314	OUTLET SEAT RETAINER	1
11+	331026	OUTLET SEAT	1
12+*	111457	O-RING	1
13+*	331027	OUTLET BALL	1
14+		PISTON	1
15*	331018	SPACER	1
16*	331025	BELLEVILLE SPRINGS	3
17*	331022	MALE GLAND	1
18*	331023	PACKING POLYETHYLENE	3
19*	331021	FEMALE GLAND	1
20	331019	PACKING HOLDER	1
21	331037	PACKING NUT	1
22*	331307	PACKING LEATHER	2
23*	331306	PACKING LEATHER	4
24*	107313	WHITE O-RING	1
25*	108771	BLACK O-RING	1
26	867783	CAP	1
*	331210	PACKING KIT	
+	331093	PISTON ASSEMBLY	

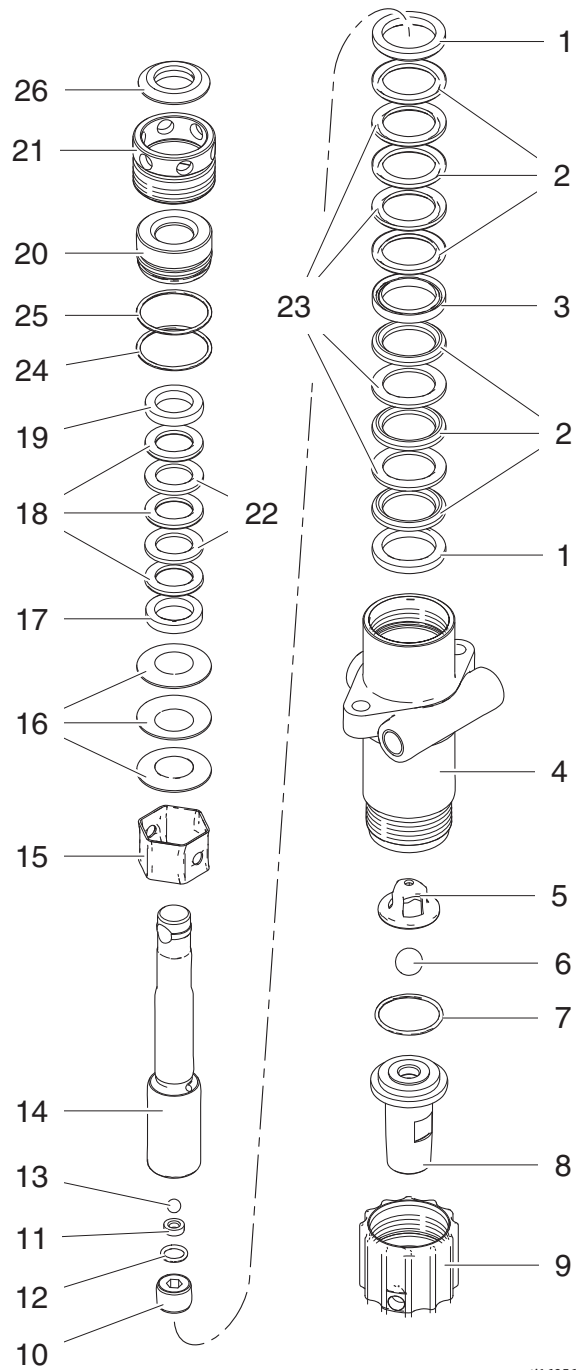

ti16056a

Gearbox Sleeve Bearing Replacement

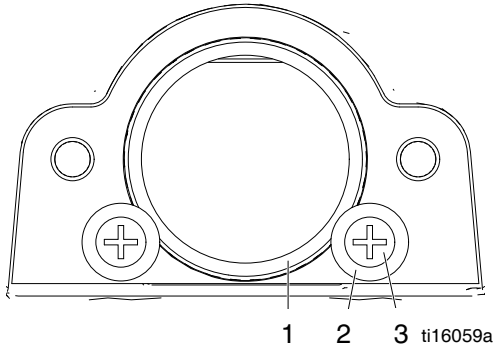

Ref.	Part	Description	Qty
1	331061	SLEEVE BEARING	1
2	331103	WASHER	2
3	331197	SCREW	2

When replacing item (1), cover outside of sleeve with 6 drops of Loctite 246 prior to inserting into cover assembly.

Suction Assemblies

Standard Suction Assembly (331284)

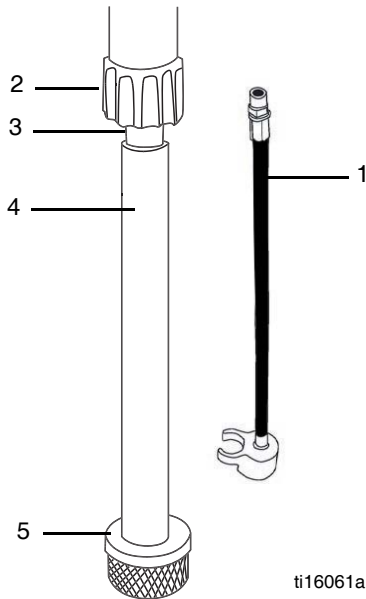

Optional Suction Assembly (865717)

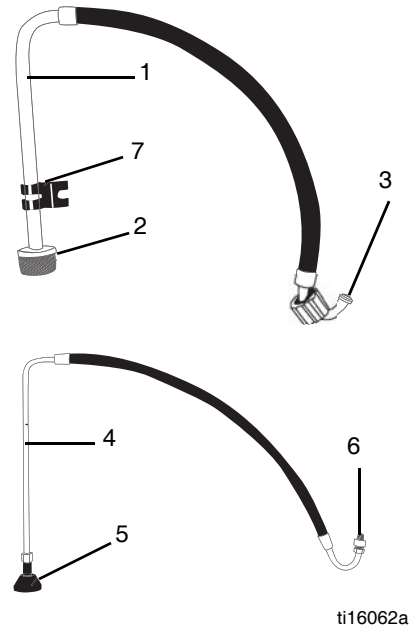

Ref.	Part	Description	Qty
1	301348	BYPASS HOSE ASSEMBLY	1
2	331034	SUCTION NUT	1
3	331292	SUCTION SEAT ASSEMBLY	1
4	331400	INLET TUBE	1

Ref.	Part	Description	Qty
1	331290	SUCTION HOSE ASSEMBLY	1
2	187651	INLET STRAINER	1
3	867370	PTFE O-RING	1
4*		DRAIN HOSE	1
5*	241920	THREADED DEFLECTOR	1
6*	867759	MALE CONNECTOR	1
7*	276888	DRAIN LINE CLIP	1

* SOLD IN KIT 865721

Electrical System

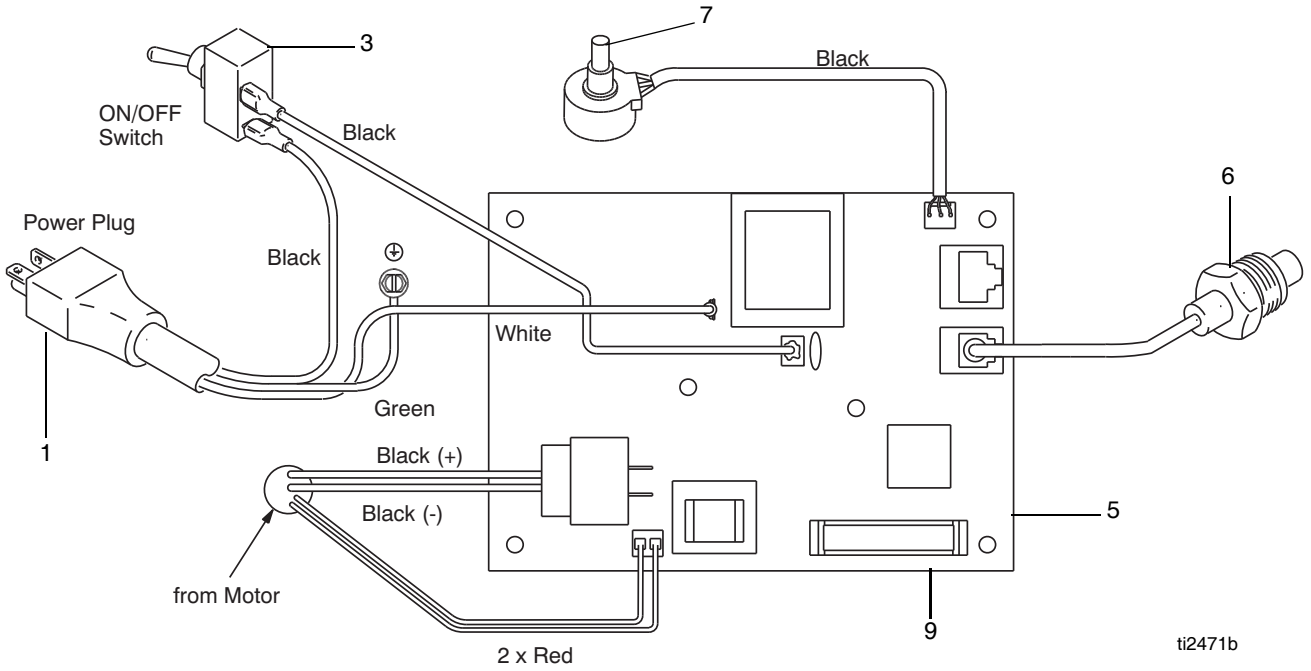

Ref. Part	Description	Qty	Ref. Part	Description	Qty
1	331163 ELECTRICAL CORD110V	1	6	243222 KIT, REPAIR, TRANSDUCER	1
3	301083 TOGGLE SWITCH	1	7	256219 POTENTIOMETER	1
5	PRESSURE CONTROL ASSEMBLY 110V	1	▲	15H085 LABEL, Warning	1

▲ Additional warning labels are available at no cost



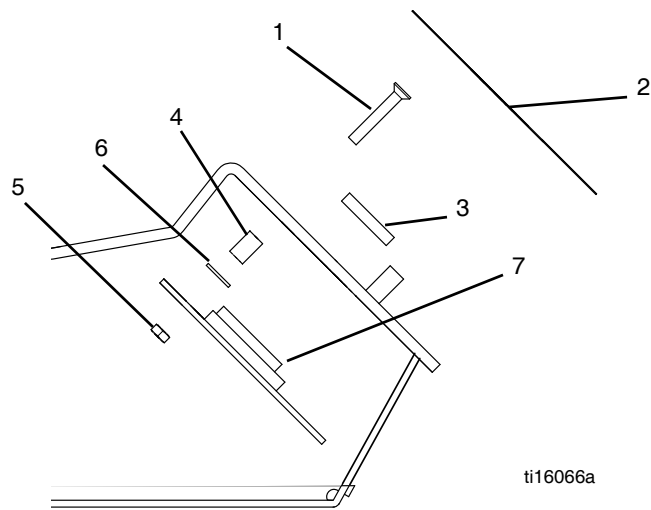







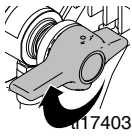







Electrical Components

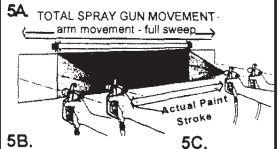

ti16066a

Ref.	Part	Description	Qty	Ref.	Part	Description	Qty
1	867816	SCREW	2	5	867817	NUT	2
2	867804	LABEL, PRESSURE CONTROL	1	6		LCD DISPLAY (PSI)	1
3	867798	WINDOW	1	7	867731	WASHER	2
4	117281	SPACER	2		867821	LCD DISPLAY Kit (PSI) Includes 1, 3, 4, 5, 6, 7	1

LP 540 HD Series Electric Paint Sprayer Quick Reference Guide

Operation	
<p>Prime Pressure Relief Valve (Prime-PR Valve) Used to relieve pressure from gun, hose and tip and to prime the unit when in OPEN position. (It is in open position when there is a wider gap between handle and body).</p>  <p>ti17403a</p> <p>When in the CLOSED position, there is only a very slight gap between handle and body. When the relief valve is closed the system is pressurized.</p>  <p>ti17403a</p>	<p>Pressure Control Knob Used to adjust pressure only. DOES NOT relieve pressure from gun and system. Turn clockwise to increase pressure, counterclockwise to decrease pressure.</p>  <p>ti16048a</p> <p>ON/OFF Toggle Switch Turns the unit ON and OFF</p>  <p>ti16067a</p>
STEP 1	
<p>1A. Read safety rules! Read & understand all warnings & safety rules before operating equipment. Know how to lock the gun trigger lock before operating the equipment.</p> <p>1B. Stir paint and if necessary strain paint using a paint strainer bag to remove lumps.</p>	<p>1A. READ SAFETY INFORMATION FIRST!</p> <p>1B.  ti16068a</p>
STEP 2	
<p>2A. Check gun/hose connections to make sure they are tight.</p> <p>2B. Lock gun trigger lock (Airlessco gun shown). Plug into 3 pronged grounded electrical outlet. Extension cord must be 3 wire, 12 gauge. Do not coil cord.</p>	<p>2A.  ti16069a</p> <p>2B.  LOCK per Gun Instructions</p>
STEP 3	
<p>3A. Put pump suction tube into bucket of paint.</p> <p>3B. Turn the Prime-Pressure Relief Valve to open position (wide gap between handle and body). Turn toggle switch ON, and adjust to low pressure on the pressure control knob. The unit will now self prime.</p>	<p>3A.  ti16070a</p> <p>3B.  OPEN (wide gap)  LOW PRESSURE</p>
STEP 4	
<p>4A. Wait about one minute until fluid comes out of the return tube (smaller diameter tube).</p> <p>4B. Turn the Prime-Pressure Relief Valve to closed position. (slight gap between handle and body) The unit is now pressurized.</p>	<p>4A.  ti16071a</p> <p>4B.  CLOSED (slight gap)</p>
STEP 5	
<p>Leave the Prime-Pressure Relief Valve fully closed and very carefully unlock the gun trigger lock.</p> <p>5A. Aim the gun 12" from test surface cardboard and spray out the storage solution. Turn the pressure control knob clockwise to increase pressure. Increase the pressure enough to atomize the paint and give a full pattern. Use the lowest pressure possible.</p> <p>5B. Always keep the gun perpendicular to the surface. Move the gun at a steady rate. It is important to "trigger" the gun after gun movement has begun and release trigger before gun movement ends.</p> <p>5C. Overlap half the width of each paint stroke.</p>	<p>5A.  TOTAL SPRAY GUN MOVEMENT - arm movement - full sweep</p> <p>5B.  Actual Paint Stroke</p> <p>5C. </p> <p>ti16072a</p>
STEP 6	
<p>6A. Release pressure when you stop spraying and before servicing gun or machine or before changing or cleaning gun tip by:</p> <ol style="list-style-type: none"> 1. Lock the gun trigger lock. 2. Turn toggle switch to OFF position and unplug from electrical outlet. 3. Release gun trigger lock and trigger gun to relieve residual pressure 4. Turn Prime/PR Valve to open position. 5. Relock gun trigger lock <p>6B. Submerge gun in water (if using latex) or thinner (oil-base) to prevent from drying in the gun nozzle.</p>	<p>6A. Pressure Relief Procedure</p> <ol style="list-style-type: none"> 1.  LOCK 2.  UNPLUG 3.  4.  OPEN (wide gap) 5.  LOCK <p>ti16073a</p>

Cleaning

- Always use low pressure in the cleaning process.
- Always remove spray tip before cleaning - AFTER following the Pressure Relief Procedure!
- Use a metal bucket for cleaning and maintain firm metal to metal contact to gun to the bucket.

Tools and Equipment Needed

- | | |
|---|---|
| 1. Soft bristle brush, clean-up rags. | 4. Empty bucket for wastes. |
| 2. 8" crescent wrench for removing gun tip and filter in gun handle. | 5. Storage solution of Pump Conditioner mixed with 1 gallon of water if using latex OR compatible paint thinner if using oil-based paint. |
| 3. Prepared 5 gallon bucket of soapy water if using latex, or mineral spirits if using oil-based. (Second bucket will usually be required). | |

STEP 1

- 1A. **IMPORTANT:** Relieve pressure by following the Pressure Relief Procedure, Step 6 of Operation, and be sure gun trigger lock is in the locked position.
- 1B. Remove tip and tip guard from spray gun and place in mineral spirits or water.

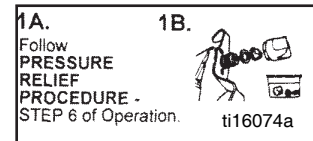

STEP 2

Turn unit ON. Turn pressure control knob to low pressure.

- 2A. Lift suction tube and return tube out of paint and hold over paint bucket. Any paint remaining in the unit will return into the bucket out through the return tube.
- 2B. Wipe excess paint from suction tube.
- 2C. Place suction tube into prepared bucket of water or mineral spirits.

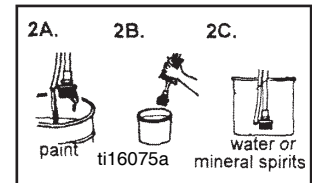

STEP 3

Release the gun trigger lock very carefully.

- 3A. Turn the Prime/PR Valve to be closed position. Adjust the pressure control knob for minimum pressure. **Important: Never use high pressure for cleaning.**
- 3B. Trigger gun into paint bucket to allow paint to run out of hose and gun
- 3C. Place gun over empty metal bucket and trigger gun using VERY LOW PRESSURE and maintaining firm metal to metal contact for 3-4 minutes until it runs clean. (Second bucket may be required)

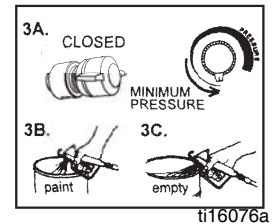

STEP 4

- 4A. **IMPORTANT: Follow Pressure Relief Procedure Step 6A of Operation.**
- 4B. Remove filters from suction tube and gun handle. Clean with water or mineral spirits and soft brush and reassemble suction and gun filter only. DO NOT reassemble gun tip and tip guard at this point.



STEP 5

- 5A. Mix bottle of Pump Conditioner with 1 gallon of water or prepared mineral spirits and put suction tube into pail. Prime unit (Prime/PR Valve Open Position and Pressure Control Knob in low position.) Trigger gun to fill the hose and gun. LEAVE this mixture in the pump and hose for storage. DO NOT DISCHARGE. Turn motor off while the suction tube remains in the bucket.
- 5B. Disconnect from power.
- 5C. Roll up hose and tape. Now reassemble gun with spray tip and tip guard. After you have disconnected sprayer from electrical power, turn Prime/PR Valve to closed position for storage.

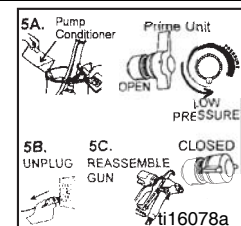

Technical Data

Airless Paint Sprayer		
	US	Metric
Maximum working pressure	3000 psi	21 MPa, 207 bar
Power requirements	120V AC, 60 hz, 11A, 1 phase	
Generator required	3000 w minimum	
Maximum delivery	0.57 gpm	2.2 lpm
Maximum tip size	0.025	
Fluid outlet npsm	1/4 in.	
Noise		
Sound power*	91 dBa	
Sound pressure*	75 dBa	
Wetted parts	zinc and nickel-plated carbon steel, nylon, stainless steel, PTFE, acetal, leather, UHMWPE, aluminum, tungsten carbide	
<i>*Sound power measured per ISO-3744.</i>		
<i>*Sound pressure measured at 3.3 feet (1 meter) from equipment.</i>		
<i>Recommend using 50% duty cycle</i>		

Airlessco Standard Warranty

Airlessco warrants all equipment referenced in this document which is manufactured by Airlessco and bearing its name to be free from defects in material and workmanship on the date of sale to the original purchaser for use. With the exception of any special, extended, or limited warranty published by Airlessco, Airlessco will, for a period of twelve months from the date of sale, repair or replace any part of the equipment determined by Airlessco to be defective. This warranty applies only when the equipment is installed, operated and maintained in accordance with Airlessco's written recommendations.

This warranty does not cover, and Airlessco shall not be liable for general wear and tear, or any malfunction, damage or wear caused by faulty installation, misapplication, abrasion, corrosion, inadequate or improper maintenance, negligence, accident, tampering, or substitution of non-Airlessco component parts. Nor shall Airlessco be liable for malfunction, damage or wear caused by the incompatibility of Airlessco equipment with structures, accessories, equipment or materials not supplied by Airlessco, or the improper design, manufacture, installation, operation or maintenance of structures, accessories, equipment or materials not supplied by Airlessco.

This warranty is conditioned upon the prepaid return of the equipment claimed to be defective to an authorized Airlessco distributor for verification of the claimed defect. If the claimed defect is verified, Airlessco will repair or replace free of charge any defective parts. The equipment will be returned to the original purchaser transportation prepaid. If inspection of the equipment does not disclose any defect in material or workmanship, repairs will be made at a reasonable charge, which charges may include the costs of parts, labor, and transportation.

THIS WARRANTY IS EXCLUSIVE, AND IS IN LIEU OF ANY OTHER WARRANTIES, EXPRESS OR IMPLIED, INCLUDING BUT NOT LIMITED TO WARRANTY OF MERCHANTABILITY OR WARRANTY OF FITNESS FOR A PARTICULAR PURPOSE.

Airlessco's sole obligation and buyer's sole remedy for any breach of warranty shall be as set forth above. The buyer agrees that no other remedy (including, but not limited to, incidental or consequential damages for lost profits, lost sales, injury to person or property, or any other incidental or consequential loss) shall be available. Any action for breach of warranty must be brought within two (2) years of the date of sale.

AIRLESSCO MAKES NO WARRANTY, AND DISCLAIMS ALL IMPLIED WARRANTIES OF MERCHANTABILITY AND FITNESS FOR A PARTICULAR PURPOSE, IN CONNECTION WITH ACCESSORIES, EQUIPMENT, MATERIALS OR COMPONENTS SOLD BUT NOT MANUFACTURED BY Airlessco. These items sold, but not manufactured by Airlessco (such as electric motors, switches, hose, etc.), are subject to the warranty, if any, of their manufacturer. Airlessco will provide purchaser with reasonable assistance in making any claim for breach of these warranties.

In no event will Airlessco be liable for indirect, incidental, special or consequential damages resulting from Airlessco supplying equipment hereunder, or the furnishing, performance, or use of any products or other goods sold hereto, whether due to a breach of contract, breach of warranty, the negligence of Airlessco, or otherwise.

FOR AIRLESSCO CANADA CUSTOMERS

The Parties acknowledge that they have required that the present document, as well as all documents, notices and legal proceedings entered into, given or instituted pursuant hereto or relating directly or indirectly hereto, be drawn up in English. Les parties reconnaissent avoir convenu que la rédaction du présente document sera en Anglais, ainsi que tous documents, avis et procédures judiciaires exécutés, donnés ou intentés, à la suite de ou en rapport, directement ou indirectement, avec les procédures concernées.

*All written and visual data contained in this document reflects the latest product information available at the time of publication.
Graco reserves the right to make changes at any time without notice.*

Original instructions. This manual contains English. MM 3A1190

Graco Headquarters: Minneapolis

International Offices: Belgium, China, Japan, Korea

GRACO INC. AND SUBSIDIARIES • P.O. BOX 1441 • MINNEAPOLIS MN 55440-1441 • USA
Copyright 2010, Graco Inc. All Graco manufacturing locations are registered to ISO 9001.

www.graco.com

Revision H, May 2016