

Electric Airless Sprayers

For portable spray application of architectural paints and coatings. For professional use only.

Not approved to European explosive atmosphere requirements.

Models

- 24F562(SP400 Hi Boy)
- 24F564 (Mustang 4700 Hi Boy)
- 24F561 (SP400 Stand)
- 24F563 (Mustang 4700 Stand)

- SP400 Stand Model 24F561
- Mustang 4700 Stand Model 24F563

3300 psi (22.7MPa, 227 bar) Maximum Working Pressure



Important Safety Instructions

Read all warnings and instructions in this manual. Save these instructions.

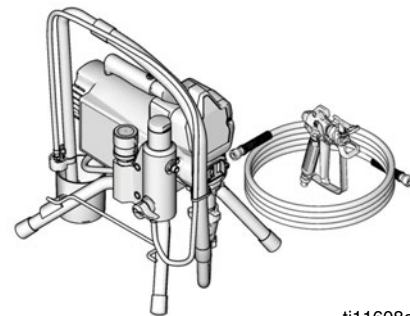

ti11608a

Related Manuals



3A1180



312363 312365 312364

English Français Español



312362

- SP400 HiBoy Model 24F562
- Mustang 4700 HiBoy Model 24F564

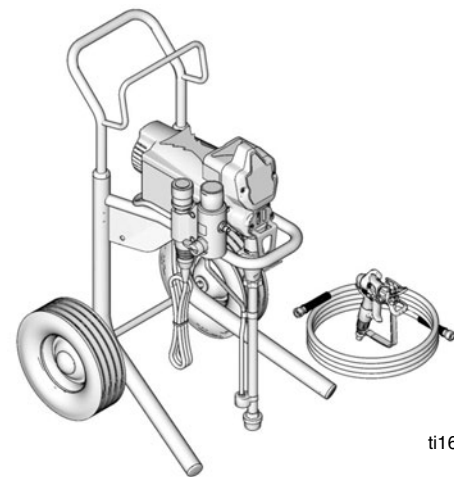

ti16088a

Warnings

The following warnings are for the setup, use, grounding, maintenance, and repair of this equipment. The exclamation point symbol alerts you to a general warning and the hazard symbols refer to procedure-specific risks. When these symbols appear in the body of this manual, refer back to these Warnings. Product-specific hazard symbols and warnings not covered in this section may appear throughout the body of this manual where applicable.

WARNING



GROUNDING

This product must be grounded. In the event of an electrical short circuit, grounding reduces the risk of electric shock by providing an escape wire for the electric current. This product is equipped with a cord having a grounding wire with an appropriate grounding plug. The plug must be plugged into an outlet that is properly installed and grounded in accordance with all local codes and ordinances.

- Improper installation of the grounding plug is able to result in a risk of electric shock.
- When repair or replacement of the cord or plug is required, do not connect the grounding wire to either flat blade terminal.
- The wire with insulation having an outer surface that is green with or without yellow stripes is the grounding wire.
- Check with a qualified electrician or serviceman when the grounding instructions are not completely understood, or when in doubt as to whether the product is properly grounded.
- Do not modify the plug provided; if it does not fit the outlet, have the proper outlet installed by a qualified electrician.
- This product is for use on a nominal 120V circuit and has a grounding plug similar to the plug illustrated in the figure below.

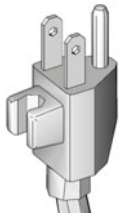

- Only connect the product to an outlet having the same configuration as the plug.
- Do not use an adapter with this product.

Extension Cords:

- Use only a 3-wire extension cord that has a 3-blade grounding plug and a 3-slot receptacle that accepts the plug on the product.
- Make sure your extension cord is not damaged. If an extension cord is necessary, use 12 AWG (2.5 mm²) minimum to carry the current that the product draws.
- An undersized cord results in a drop in line voltage and loss of power and overheating.

WARNING



FIRE AND EXPLOSION HAZARD

Flammable fumes, such as solvent and paint fumes, in work area can ignite or explode. To help prevent fire and explosion:

- Do not spray flammable or combustible materials near an open flame or sources of ignition such as cigarettes, motors, and electrical equipment.
- Paint or solvent flowing through the equipment is able to result in static electricity. Static electricity creates a risk of fire or explosion in the presence of paint or solvent fumes. All parts of the spray system, including the pump, hose assembly, spray gun, and objects in and around the spray area shall be properly grounded to protect against static discharge and sparks. Use Airlessco conductive or grounded high-pressure airless paint sprayer hoses.
- Verify that all containers and collection systems are grounded to prevent static discharge.
- Connect to a grounded outlet and use grounded extensions cords. Do not use a 3-to-2 adapter.
- Do not use a paint or a solvent containing halogenated hydrocarbons.
- Keep spray area well-ventilated. Keep a good supply of fresh air moving through the area. Keep pump assembly in a well ventilated area. Do not spray pump assembly.
- Do not smoke in the spray area.
- Do not operate light switches, engines, or similar spark producing products in the spray area.
- Keep area clean and free of paint or solvent containers, rags, and other flammable materials.
- Know the contents of the paints and solvents being sprayed. Read all Material Safety Data Sheets (MSDS) and container labels provided with the paints and solvents. Follow the paint and solvents manufacturer's safety instructions.
- Fire extinguisher equipment shall be present and working.
- Sprayer generates sparks. When flammable liquid is used in or near the sprayer or for flushing or cleaning, keep sprayer at least 20 feet (6 m) away from explosive vapors.

⚠️ WARNING



ELECTRIC SHOCK HAZARD

This equipment must be grounded. Improper grounding, setup, or usage of the system can cause electric shock.

- Turn off and disconnect power cord before servicing equipment.
- Use only grounded electrical outlets.
- Use only 3-wire extension cords.
- Ensure ground prongs are intact on power and extension cords.
- Do not expose to rain. Store indoors.



SKIN INJECTION HAZARD

Do not aim the gun at, or spray any person or animal.

- Keep hands and other body parts away from the discharge. For example, do not try to stop leaks with any part of the body.
- Always use the nozzle tip guard. Do not spray without nozzle tip guard in place.
- Use Airlessco nozzle tips.
- Use caution when cleaning and changing nozzle tips. In the case where the nozzle tip clogs while spraying, follow the **Pressure Relief Procedure** for turning off the unit and relieving the pressure before removing the nozzle tip to clean.
- Do not leave the unit energized or under pressure while unattended. When the unit is not in use, turn off the unit and follow the **Pressure Relief Procedure** for turning off the unit.
- High-pressure spray is able to inject toxins into the body and cause serious bodily injury. In the event that injection occurs, **get immediate surgical treatment.**
- Check hoses and parts for signs of damage. Replace any damaged hoses or parts.
- This system is capable of producing 3000 psi. Use Airlessco replacement parts or accessories that are rated a minimum of 3000 psi.
- Always engage the trigger lock when not spraying. Verify the trigger lock is functioning properly.
- Verify that all connections are secure before operating the unit.
- Know how to stop the unit and bleed pressure quickly. Be thoroughly familiar with the controls.

! WARNING



EQUIPMENT MISUSE HAZARD

Misuse can cause death or serious injury.

- Always wear appropriate gloves, eye protection, and a respirator or mask when painting.
- Do not operate or spray near children. Keep children away from equipment at all times.
- Do not overreach or stand on an unstable support. Keep effective footing and balance at all times.
- Stay alert and watch what you are doing.
- Do not leave the unit energized or under pressure while unattended. When the unit is not in use, turn off the unit and follow the **Pressure Relief Procedure** for turning off the unit.
- Do not operate the unit when fatigued or under the influence of drugs or alcohol.
- Do not kink or over-bend the hose.
- Do not expose the hose to temperatures or to pressures in excess of those specified by Airlessco.
- Do not use the hose as a strength member to pull or lift the equipment.



PRESSURIZED ALUMINUM PARTS HAZARD

Use of fluids that are incompatible with aluminum in pressurized equipment can cause serious chemical reaction and equipment rupture. Failure to follow this warning can result in death, serious injury, or property damage.

- Do not use 1,1,1-trichloroethane, methylene chloride, other halogenated hydrocarbon solvents or fluids containing such solvents.
- Many other fluids may contain chemicals that can react with aluminum. Contact your material supplier for compatibility.



MOVING PARTS HAZARD

Moving parts can pinch, cut or amputate fingers and other body parts.



- Keep clear of moving parts.
- Do not operate equipment with protective guards or covers removed.
- Pressurized equipment can start without warning. Before checking, moving, or servicing equipment, follow the **Pressure Relief Procedure, page 7** and disconnect all power sources.



TOXIC FLUID OR FUMES HAZARD

Toxic fluids or fumes can cause serious injury or death if splashed in the eyes or on skin, inhaled, or swallowed.

- Read MSDSs to know the specific hazards of the fluids you are using.
- Store hazardous fluid in approved containers, and dispose of it according to applicable guidelines.



PERSONAL PROTECTIVE EQUIPMENT

You must wear appropriate protective equipment when operating, servicing, or when in the operating area of the equipment to help protect you from serious injury, including eye injury, hearing loss, inhalation of toxic fumes, and burns. This equipment includes but is not limited to:

- Protective eyewear, and hearing protection.
- Respirators, protective clothing, and gloves as recommended by the fluid and solvent manufacturer.

Installation

Grounding and Electric Requirements

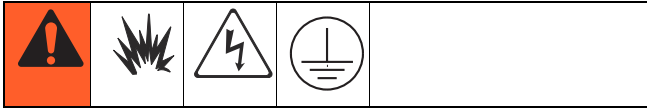

The sprayer cord includes a grounding wire with an appropriate grounding contact.

The sprayers require:

110-120V Units: 100-130 VAC, 50/60 Hz, 11A, 1 phase, circuit with a grounding receptacle.

Never use an outlet that is not grounded or an adapter.

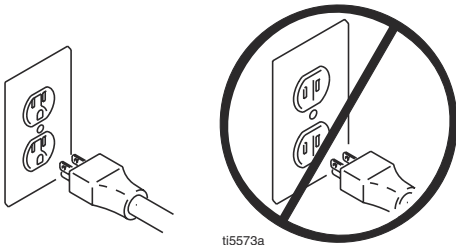

ti5573a

Do not use the sprayer if the electrical cord has a damaged ground contact. Only use an extension cord with an undamaged ground contact.

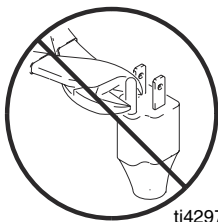

ti4297a

Recommended extension cords:

- 110-120V: 3-wire, 12 AWG (2.5 mm²) minimum.

NOTE: Smaller gauge or longer extension cords may reduce sprayer performance.

Spray gun: ground through connection to a properly grounded fluid hose and pump.

Fluid supply container: follow local code.

Solvent and Oil-based fluids: follow local code. Use only conductive metal pails placed on a grounded surface such as concrete. Do not place the pail on a non-conductive surface such as paper or cardboard, which interrupts grounding continuity.

Grounding the metal pail: connect a ground wire to the pail by clamping one end to pail and other end to ground such as a water pipe.

To maintain grounding continuity when flushing or relieving pressure: hold metal part of the spray gun firmly to the side of a grounded metal pail, then trigger the gun.



ti11558a

Pressure Relief Procedure



Follow this **Pressure Relief Procedure** whenever you are instructed to relieve pressure, stop spraying, check or service equipment or install or clean spray tip.

1. Turn OFF power and turn pressure control to lowest pressure setting.
2. Hold gun against side of grounded metal flushing pail. Trigger gun to relieve pressure.

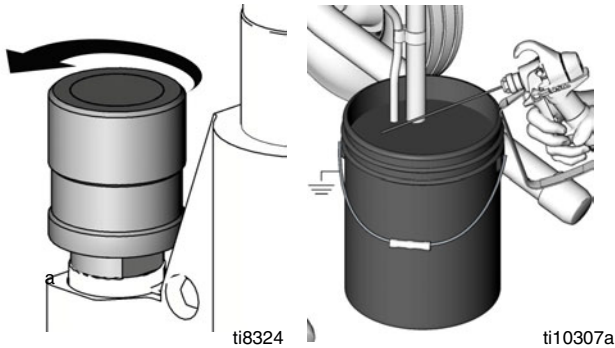

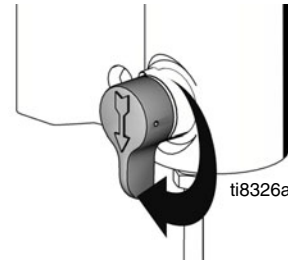

3. Turn prime valve down.



If you suspect the spray tip or hose is clogged or that pressure has not been fully relieved after following the steps above, VERY SLOWLY loosen tip guard retaining nut or hose end coupling to relieve pressure gradually, then loosen completely. Clear hose or tip obstruction.

4. Engage trigger safety lock on gun if unit is being shut down or left unattended.

General Repair Information

			
<p>Flammable materials spilled on hot, bare, motor could cause fire or explosion. To reduce risk of burns, fire or explosion, do not operate sprayer with cover removed.</p> <p>To reduce risk of serious injury, including electric shock:</p> <ul style="list-style-type: none">• Do not touch moving or electric parts with fingers or tools while testing repair.• Unplug sprayer when power is not required for testing.• Install all covers, gaskets, screws and washers before you operate sprayer.			

- Keep all screws, nuts, washers, gaskets, and electrical fittings removed during repair procedures. These parts usually are not provided with replacement kits.
- Test repairs after problems are corrected.
- If sprayer does not operate properly, review repair procedure to verify you did it correctly. See **Troubleshooting, page 9**.
- Overspray may build up in the air passages. Remove any overspray and residue from air passages and openings in the enclosures whenever you service sprayer.
- Do not operate the sprayer without the motor shroud in place. Replace if damaged. Motor shroud directs cooling air around motor to prevent overheating and insulates the control board from accidental electric shock.

<p>NOTICE</p> <ul style="list-style-type: none">• Do not run sprayer dry for more than 30 seconds. Doing so could damage pump packings.• Protect the internal drive parts of this sprayer from water. Openings in the cover allow for air cooling of the mechanical parts and electronics inside. If water gets in these openings, the sprayer could malfunction or be permanently damaged.• Prevent pump corrosion and damage from freezing. Never leave water or water-base paint in sprayer when its not in use in cold weather. Freezing fluids can seriously damage sprayer. Store sprayer with Pump Armor to protect sprayer during storage.

Troubleshooting



Problem	Cause	Solution
Basic Fluid Pressure	1. Pressure control knob setting. Motor will not run if set at minimum (fully counter-clockwise).	Slowly increase pressure setting to see if motor starts.
	2. Spray tip or fluid filter may be clogged.	Relieve pressure, page 7. Then clear clog or clean gun filter. Refer to gun instruction manual, 312363.
Basic Mechanical	1. Pump frozen or hardened paint	Thaw sprayer if water or water-based paint has frozen in sprayer. Place sprayer in warm area to thaw. Do not start sprayer until thawed completely. If paint hardened (dried) in sprayer, replace pump packings. See Displacement Pump Replacement, page 13.
	2. Displacement pump connecting rod pin. Pin must be completely pushed into connecting rod and retaining spring must be firmly in groove or pump pin.	Push pin into place and secure with spring retainer. See Displacement Pump Replacement, page 13.
	3. Motor. Remove drive housing assembly. See Drive Housing Replacement, page 15. Try to rotate fan by hand.	Replace motor if fan won't turn. See Motor Replacement, page 27.

Problem	Cause	Solution
Basic Electrical See wiring diagram, page 28	1. Electric supply. ON/OFF switch in OFF position. Meter must read 100-130 Vac; 210-260 Vac.	Turn ON/OFF switch to ON position. Reset building circuit breaker, replace building fuses. Try another outlet.
	2. Extension cord. Check extension cord continuity with volt meter.	Replace extension cord.
	3. Sprayer power supply cord. Inspect for damage such as broken insulation or wires.	Replace power supply cord. See Power Cord Replacement, page 26.
	4. Fuse. Check replaceable fuse on control board (next to ON/OFF switch).	Replace fuse after completing motor inspection. See Fuse Replacement, page 21.
	5. Motor leads are securely fastened and properly connected to control board.	Replace loose terminals; crimp to leads. Be sure terminals are firmly connected. Clean circuit board terminals. Securely reconnect leads.
	6. Motor thermal switch. Yellow motor leads must have continuity through thermal switch.	Replace motor. See Motor Replacement, page 27.
	7. Brush cap missing or loose brush lead connections.	Install brush cap or replace brushes if leads are damaged. See Motor Brush Replacement, page 18.
	8. Brush length which must be greater than 1/4 in. (6 mm). NOTE: Brushes do not wear at the same rate on both sides of motor. Check both brushes.	Replace brushes. See Motor Brush Replacement, page 18.
	9. Motor armature commutator for burn spots, gouges and extreme roughness.	Remove motor and have motor shop resurface commutator if possible. See Motor Replacement, page 27.
	10. Motor armature for shorts using armature tester (growler) or perform Spin Test, page 16.	Replace motor. See Motor Replacement, page 27.
	11. Pressure control not plugged in to control board.	Insert pressure control connector into control board.

Problem	Cause	Solution
Low Output	1. Worn spray tip.	Relieve pressure, page 7. Replace tip. Refer to gun instruction manual, 312363.
	2. Verify pump does not continue to stroke when gun trigger is released.	Service pump. See Displacement Pump Replacement, page 13.
	3. Prime valve leaking.	Relieve pressure, page 7. Then repair prime valve. See Drain Valve Replacement, page 24.
	4. Suction tube connections.	Tighten any loose connections. Check o-ring on suction tube.
	5. Electric supply with volt meter. Meter must read 100-130 Vac; 210-260 Vac. Low voltages reduce sprayer performance.	Reset building circuit breaker; replace building fuse. Repair electrical outlet or try another outlet.
	6. Extension cord size and length.	Replace with a correct, grounded extension cord. See Grounding and Electric Requirements, page 6.
	7. Leads from motor to circuit board for damaged or loose wire connectors. Inspect wiring insulation and terminals for signs of overheating.	Be sure male terminal pins are centered and firmly connected to female terminals. Replace any loose terminals or damaged wiring. Securely reconnect terminals.
	8. Worn motor brushes which must be greater than 1/4 in. (6 mm).	Replace brushes. See Motor Brush Replacement, page 18.
	9. Motor brushes binding in brush holders.	Clean brush holders. Remove carbon dust by using compressed air to blow out brush dust.
	10. Low stall pressure. Turn pressure control knob fully clockwise.	Replace pressure control assembly. See Pressure Control Assembly Replacement, page 22.
	11. Motor armature for shorts by using an armature tester (growler) or perform Spin Test, page 16.	Replace motor. See Motor Replacement, page 27.

Problem	Cause	Solution
Motor runs and pump strokes	1. Prime Valve Open.	Close prime valve.
	2. Paint supply.	Refill and reprime pump.
	3. Intake strainer clogged.	Remove and clean, then reinstall.
	4. Suction tube leaking air.	Tighten nut. Check o-ring on tube.
	5. Intake valve ball and piston ball are seating properly.	See Pump Manual 312362 . Strain paint before using to remove particles that could clog pump.
	6. Leaking around throat packing nut which may indicate worn or damaged packings.	See Pump Manual 312362 .
	7. Pump rod damaged.	See Pump Manual 312362 .
Motor runs but pump does not stroke	1. Displacement pump pin damaged or missing.	Replace pump pin if missing. Be sure retaining spring is fully in groove all around connecting rod. See Displacement Pump Replacement, page 13 .
	2. Connecting rod assembly for damage.	Replace connecting rod assembly. See Displacement Pump Replacement, page 13 .
	3. Gears or drive housing.	Inspect drive housing assembly and gears for damage and replace if necessary. See Drive Housing Replacement, page 15 .
Motor is hot and runs intermittently	1. Be sure ambient temperature where sprayer is located is not more than 115°F (46°C) and sprayer is not located in direct sun.	Move sprayer to shaded, cooler area if possible.
	2. Motor has burned windings indicated by removing positive (red) brush and seeing burned adjacent commutator bars.	Replace motor. See Motor Replacement, page 27 .
	3. Tightness of pump packing nut. Overtightening tightens packings on rod, restricts pump action and damages packings.	Loosen packing nut. Check for leaking around throat. Replace pump packings if necessary. See Pump Manual 312362 .

Displacement Pump Replacement

See manual 312362 for pump repair instructions.

Removal



1. **Relieve pressure, page 7.** Unplug sprayer from outlet.
2. Loosen two screws (11) and remove pail hanger (10).

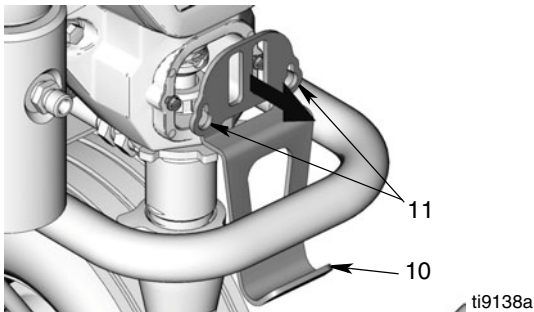

3. Loosen nut (37) and remove suction tube (39). Loosen nut (B) and remove coupled hose (42).

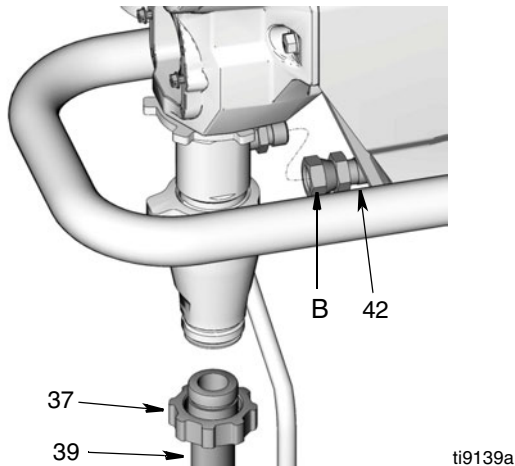

4. Cycle pump until pin (31) is in position to be removed.
5. Disconnect power cord from outlet.

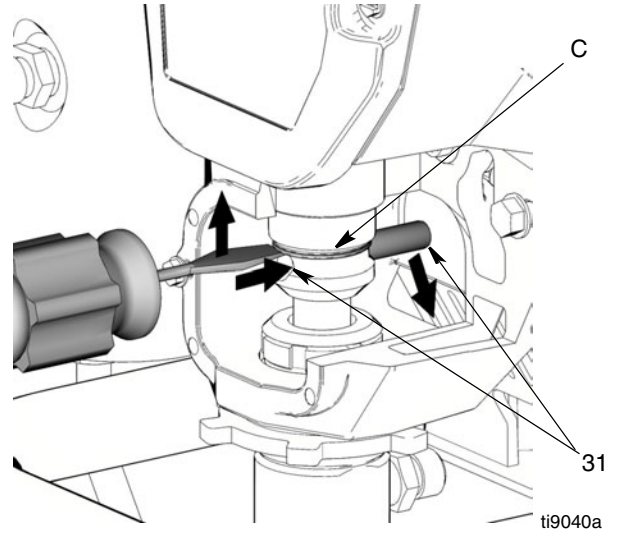

6. Push up retaining spring (C). Push out pump pin (31).

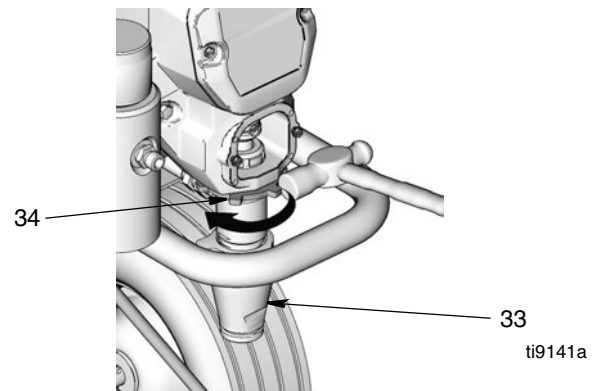

7. Loosen pump jam nut (34). Unscrew and remove pump (33).



Installation

	
<p>If pump pin works loose, parts could break off due to force of pumping action. Parts could project through air and result in serious injury or property damage.</p>	

NOTICE
<p>If the pump jam nut loosens during operation, the threads of the drive housing will be damaged.</p>

1. Extend pump piston rod fully. Apply grease to top of pump rod (D). Install jam nut (34) on pump threads.

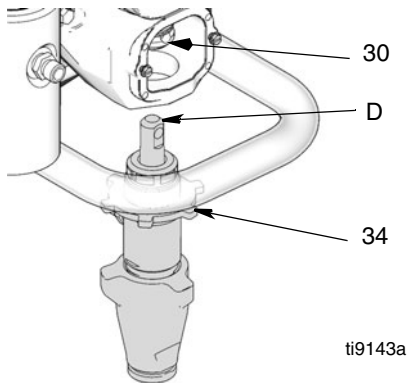

2. Install pump rod (D) into connecting rod (30).
3. Install pump pin (31). Verify retainer spring (30a) is in groove over pump pin.

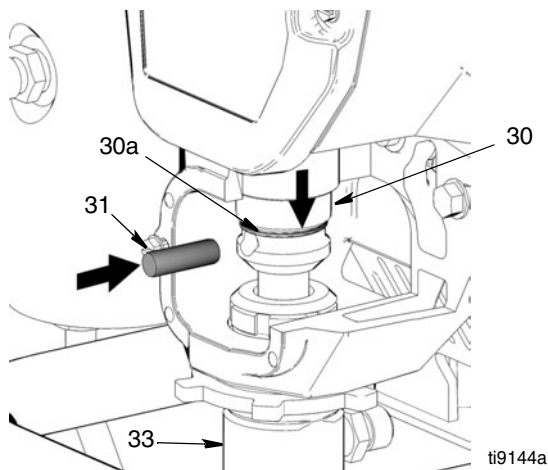

4. Push pump (33) up until pump threads engage.

5. Screw in pump until threads are flush with top of drive housing opening.

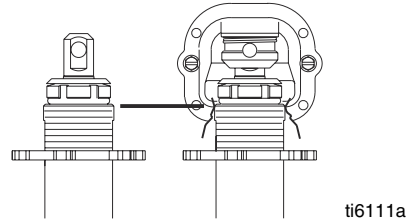

6. Align pump outlet (E) to back.

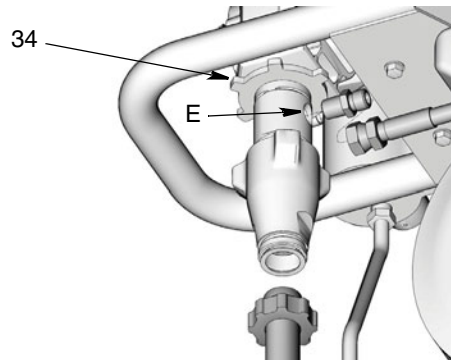

7. Screw jam nut (34) up onto pump until nut stops. Tighten jam nut by hand, then tap 1/8 to 1/4 turn with a 20 oz (maximum) hammer to approximately 75 ft-lb (102 N•m).
8. Install suction tube (39) and coupled hose (42). Tighten nuts (37) and (B).

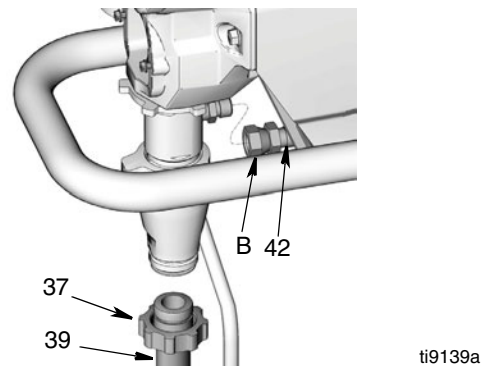

9. Fill packing nut with ASM Packing Seal® until fluid flows onto top of seal. Install pail hanger (10) with screws (11).

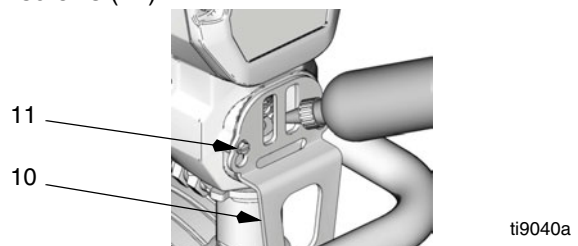

Drive Housing Replacement

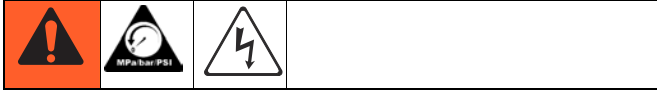

Removal

1. Relieve pressure, page 7.
2. Remove pump (33). **Displacement Pump Replacement, page 13.**
3. Disconnect power cord from outlet.

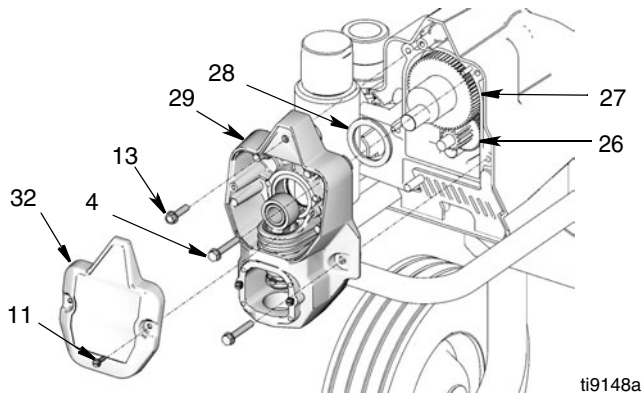

ti9148a

4. Remove two screws (11) and cover (32).
5. Remove screw (13) and four screws (4).
6. Pull drive housing (29) out of motor front endbell.
7. Remove gear cluster (27) and (26) and thrust bearing (28) from drive housing.

NOTICE

Do not drop gear cluster (27) and (26) when removing drive housing (29). Gear cluster may stay engaged in motor front endbell or drive housing.

Installation

1. Apply a liberal coat of grease to gears and needle bearing surfaces. Install thrust bearing (28) and gears (26) and (27) in motor front endbell.

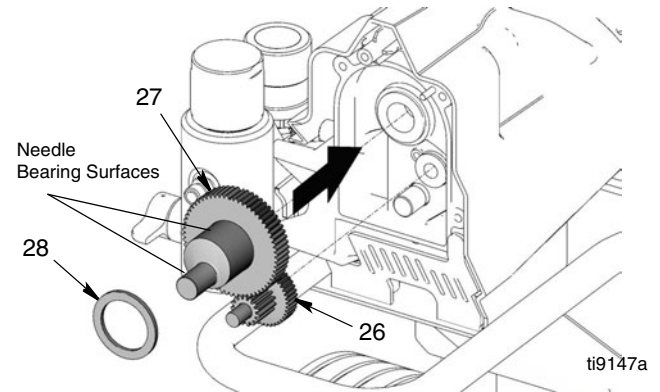

ti9147a

2. Push drive housing (29) into motor front endbell. Insert gear crank (27) through hole in connecting rod (30).

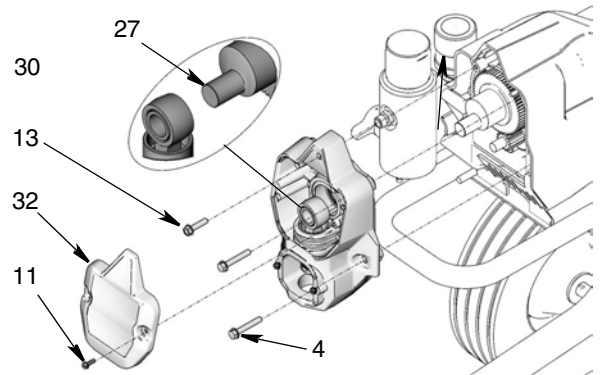

ti9149a

3. Install four screws (4) and screw (13).
4. Install cover (32) with two screws (11).
5. Install pump (33). **Displacement Pump Replacement, page 13.**

Spin Test

See *Wiring Diagrams*, page 28.



To check armature, motor winding and brush electrical continuity:

1. **Relieve Pressure**, page 7. Disconnect power cord from outlet.
2. **Hi-Boy Models Only** - Disconnect high-pressure hose at pump outlet (see page 13).
3. Remove two screws (4) and shroud (12).
4. Remove drive housing (29) (see page 15).
5. Disconnect motor connector (H).

Armature Short Circuit Test

Quickly turn motor fan by hand. If motor coasts two or three revolutions before complete stop, there are no electrical shorts. If motor does not spin freely, armature is shorted. **Replace motor, page 27.**

Armature, Brushes, and Motor Wiring Open Circuit Test (Continuity)

1. Connect red and black motor leads with test lead. Turn motor fan by hand at about two revolutions per second.

2. If uneven or no resistance, check for missing brush caps, broken brush springs, brush leads, and worn brushes. Repair as needed, page 18.
3. If still uneven or no resistance, **replace motor, page 27.**

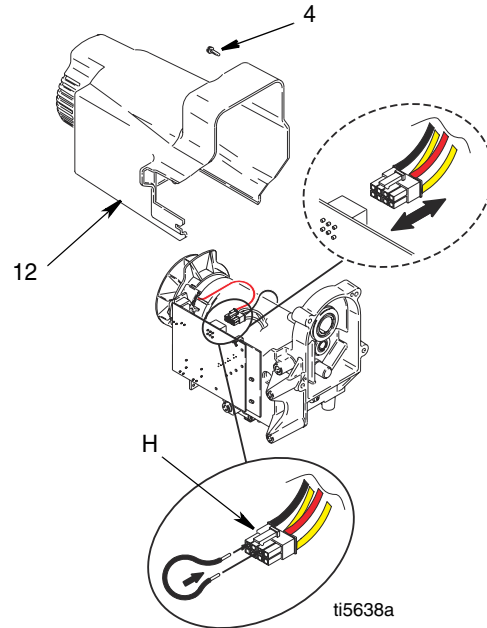

4. Reattach motor connector (H).
5. Replace drive housing (see page 15).
6. Replace shroud (12) and two screws (4).
7. **Hi-Boy Models Only** - Connect high-pressure hose at pump outlet (see page 14).

Fan Replacement

Removal

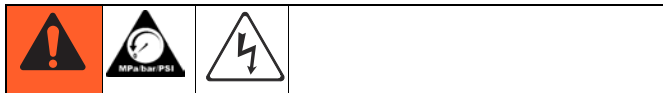

1. **Relieve Pressure, page 7.** Disconnect power cord from outlet.
2. **Hi-Boy Models Only** - Disconnect high-pressure hose at pump outlet (**see page 13**).
3. Remove two screws (4) and shroud (12).
4. Remove spring clip (57b) on back of motor.
5. Pull off fan (57a).

Installation

1. Slide new fan (57a) in place on back of motor. Be sure blades of fan face motor as shown.
2. Install spring clip (57b).
3. Replace shroud (12) and two screws (4).
4. **Hi-Boy Models Only** - Connect high-pressure hose at pump outlet (**see page 14**).

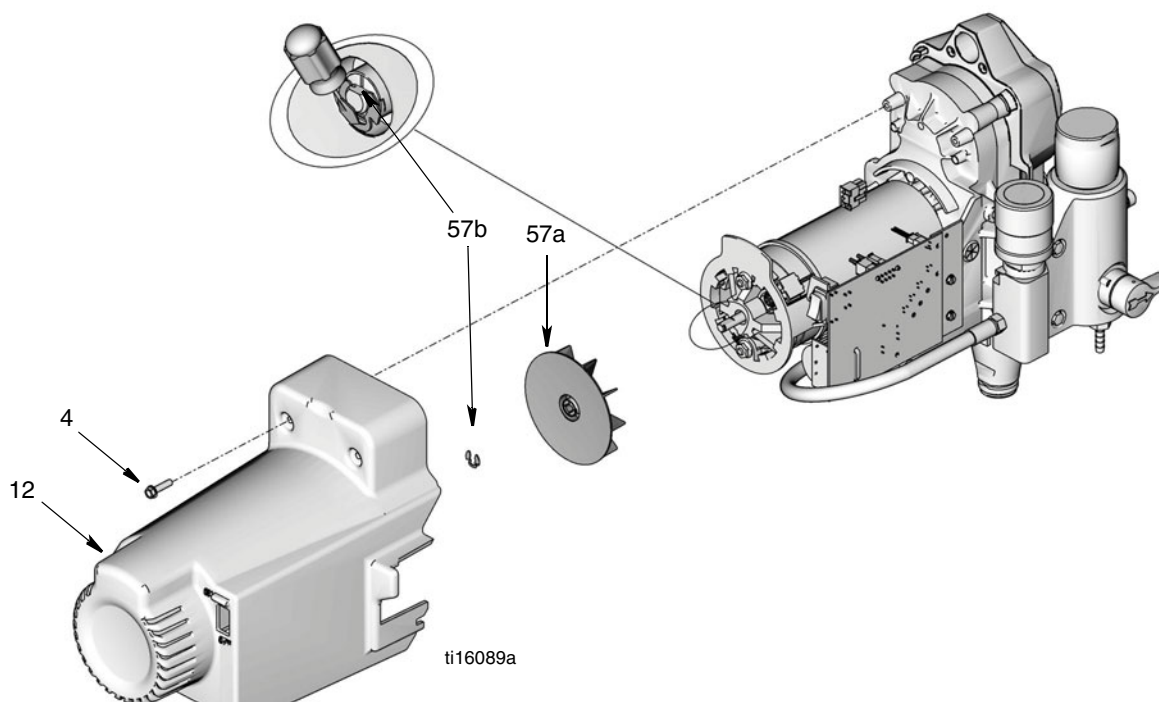

Motor Brush Replacement

See *Wiring Diagram*, page 28.

Removal

Replace brushes worn to less than 1/4 in. (6 mm). Brushes wear differently on each side of motor, check both sides.



1. **Relieve pressure, page 7.** Disconnect power cord from outlet.
2. **Hi-Boy Models Only** - Disconnect high-pressure hose at pump outlet (**see page 13**).
3. Remove two screws (4) and shroud (12) (**see illustration on page 17**).
4. Disconnect motor connector (D) from control board (18).
5. Cut tie wrap (F).
6. Locate two yellow wires (C). Cut each yellow wire at the center.
7. Pry off two brush caps (A). Remove brushes (B) from motor.
8. Discard old brush assembly.
9. Rotate fan by hand and blow compressed air into top brush holder to remove brush dust.

NOTE: Place end of a shop vacuum hose over lower brush holder. Turn on shop vacuum when you blow compressed air into top brush holder.

Installation

NOTE: Use all new parts included in brush kit. Do not reuse old parts if new replacement parts are provided.

1. Install new brushes (B) in motor with wires facing toward front of motor. Install positive (red) brush lead in top of motor and negative (black) brush lead in side of motor.
2. Push each cap (A) into place over brush. Orient each cap with the two projections on either side of

the brush lead. You will hear a snap when cap is securely in place.

3. Strip approximately 1/4 inch (6 mm) of insulation from end of each yellow wire (C) from motor.
4. Insert stripped end into end of a butt splice (E) on new brush assembly.
5. Crimp ends of butt splice (E) around each wire. Pull gently on each wire to be sure wire does not pull out of butt splice.
6. Wrap new tie wrap around motor and wires only. Trim off excess. Be sure pressure hose is not caught in tie wrap.
7. Connect motor connector (D) to control board (18).

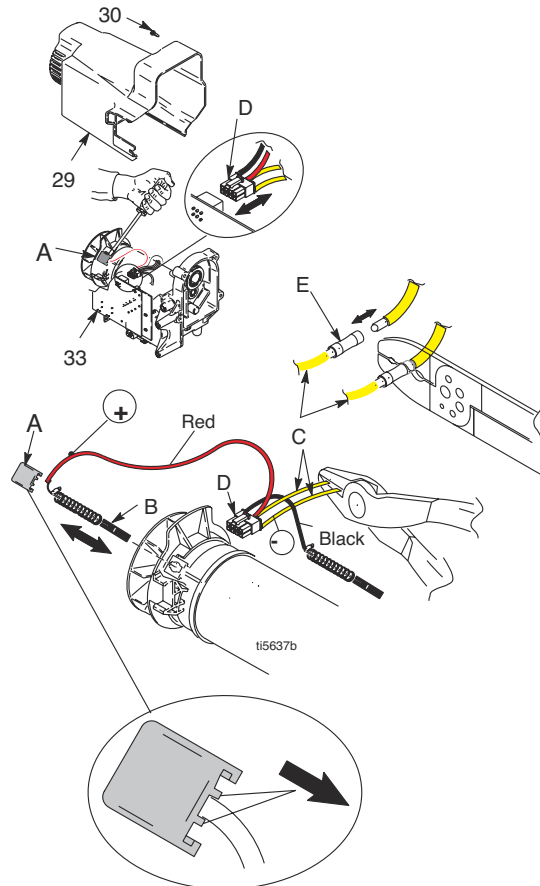

8. Replace shroud (12) and two screws (4) (**see illustration, page 17**).
9. **Hi-Boy Models Only** - Connect high-pressure hose at pump outlet (**see page 14**).

Control Board Replacement

See Wiring Diagram, page 28.

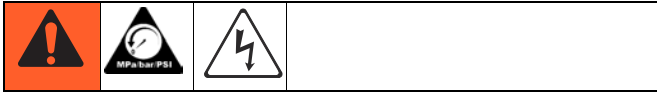

Removal

1. **Relieve pressure, page 7.** Disconnect power cord from outlet.
2. **Hi-Boy Models Only** - Disconnect high-pressure hose at pump outlet (see page 13).
3. Remove two screws (4) and shroud (12) (see illustration, page 17).
4. Disconnect pressure control assembly connector (A) from control board (18).

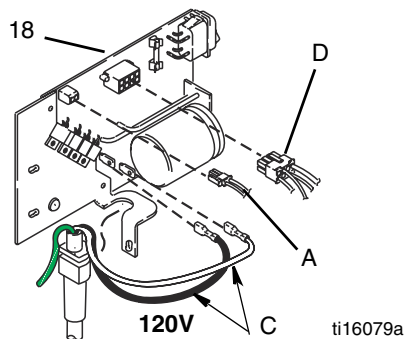

5. Disconnect motor connector (D) from control board (18).
6. Remove three screws (11) securing control board to housing (two are located on the front and one on the back next to the power cord).

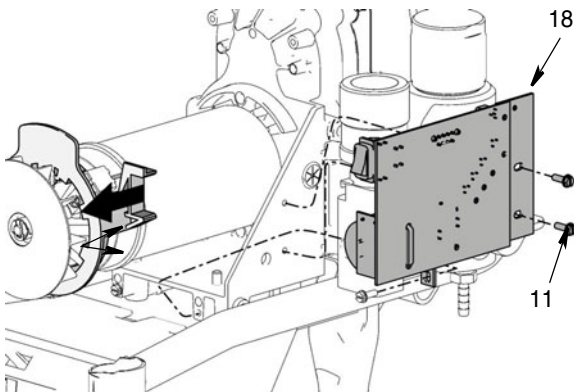

7. Pull control board out slightly and then slide control board back and off of frame.

NOTE: Make sure power cord is free and not wrapped around cord wrap.

8. Remove grommet and wires from strain relief.

NOTE: Ground wire remains attached to sprayer with grounding screw.

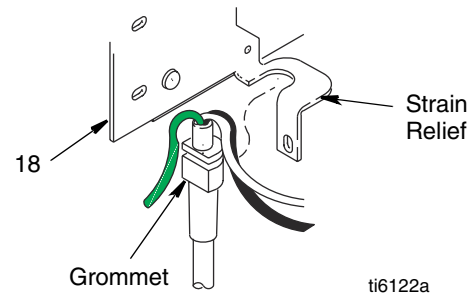

9. Remove two power cord (C) connectors from control board.

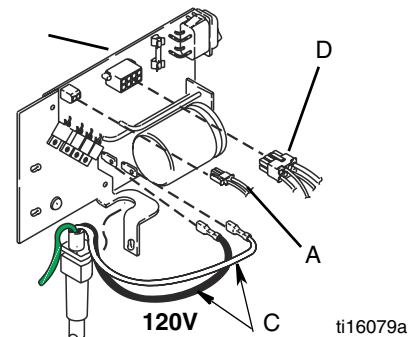

Installation

1. Push grommet and power cord wires into strain relief in control board (18).

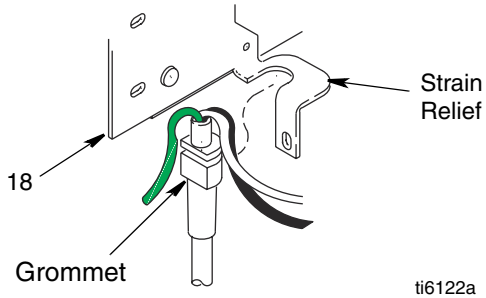

2. Connect power cord connectors to terminals indicated on control board (18).

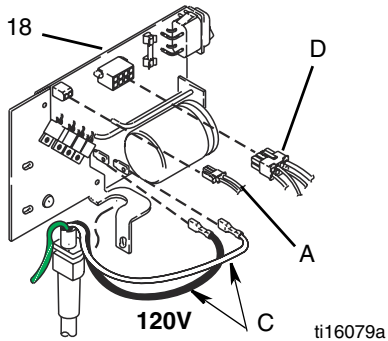

NOTE: Route power cord (19) between coupled hose (42) to filter manifold and sprayer frame.

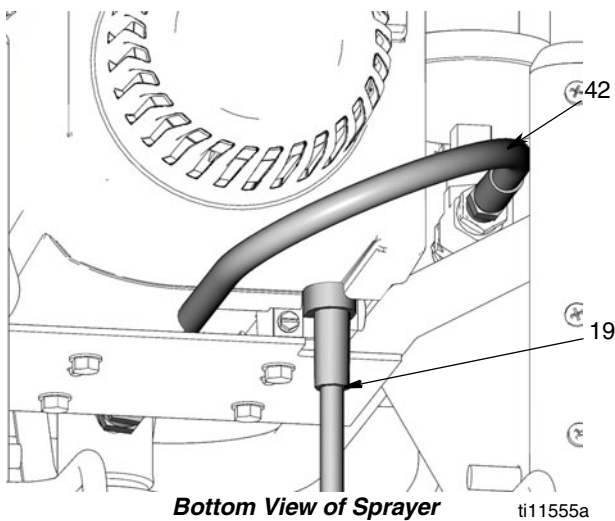

3. Slide control board into place on side of motor front endbell.

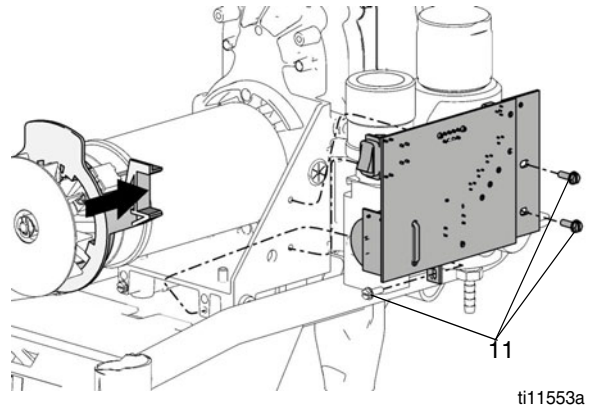

4. Replace three screws (11). Torque to 30-35 in-lb (3.4-3.9 N.m).

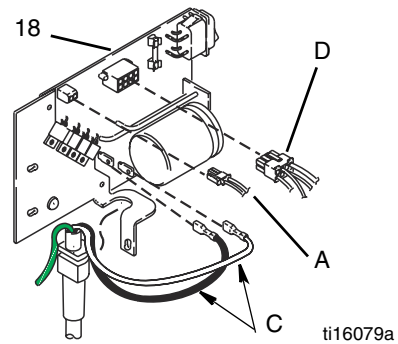

5. Connect motor connector (D) and pressure control assembly connector (A).
6. Install shroud (12) with two screws (4) (see page 17).
7. **Hi-Boy Models Only** - Connect high-pressure hose at pump outlet (see page 14).

Fuse Replacement



If the fuse is blown, check for:

- Pinched or shorted wires
- A defective motor (**see Spin Test, page 16**)
- A locked or frozen pump

Correct defective condition before replacing fuse.

Removal

1. **Relieve pressure, page 7.** Disconnect power cord from outlet.
2. **Hi-Boy Models Only** - Disconnect high-pressure hose at pump outlet (**see page 13**).
3. Remove two screws (4) and shroud (12) (**see illustration, page 17**).
4. Remove fuse from control board.

Installation

1. Install Fuse 119277 on control board.
2. Install shroud (12) and two screws (4) (**see illustration, page 17**).
3. **Hi-Boy Models Only** - Connect high-pressure hose at pump outlet (**see page 14**).

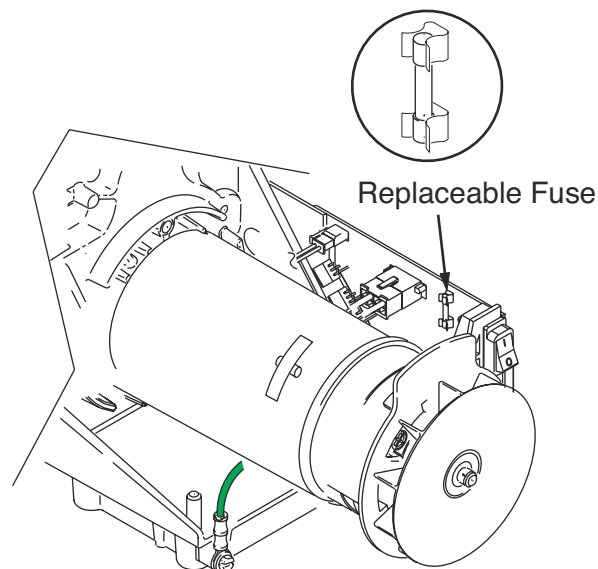

ti9134b

Pressure Control Assembly Replacement

See Wiring Diagram, page 28.

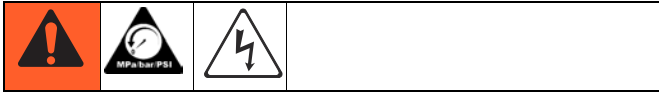

Removal

1. **Relieve pressure, page 7.** Disconnect power cord from outlet.
2. **Hi-Boy Models Only** - Disconnect high-pressure hose at pump outlet (**see page 13**).
3. Remove two screws (4) and shroud (12) (**see illustration, page 17**).
4. Disconnect pressure switch connector (A) from control board (18). Pull bushing (23) from hole (K).

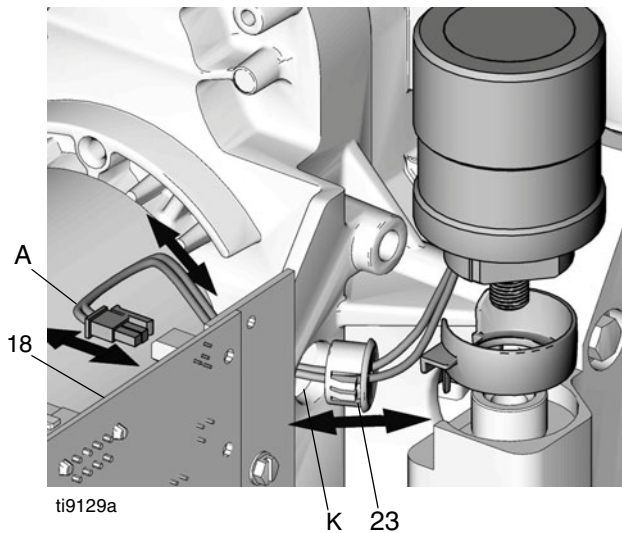

5. Pull wires through hole (K).
6. Turn pressure control knob (17) counter clockwise as far as you can to access flats on either side of pressure control.

7. Loosen and unscrew pressure control.

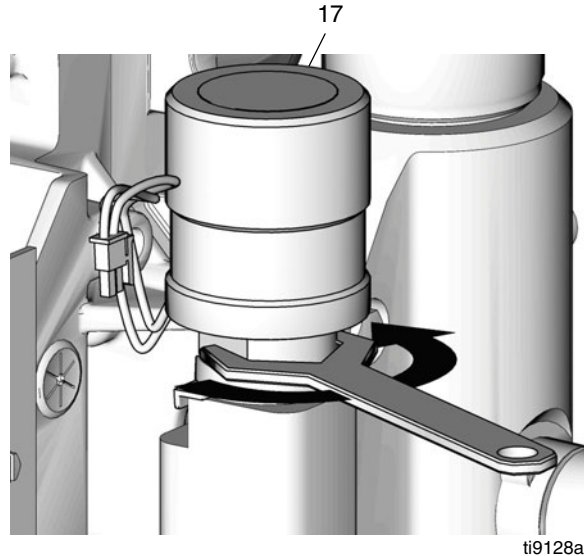

NOTICE

If you plan to reuse pressure control, be careful not to damage or tangle wires when unscrewing pressure control.

8. Remove pressure control.

Installation

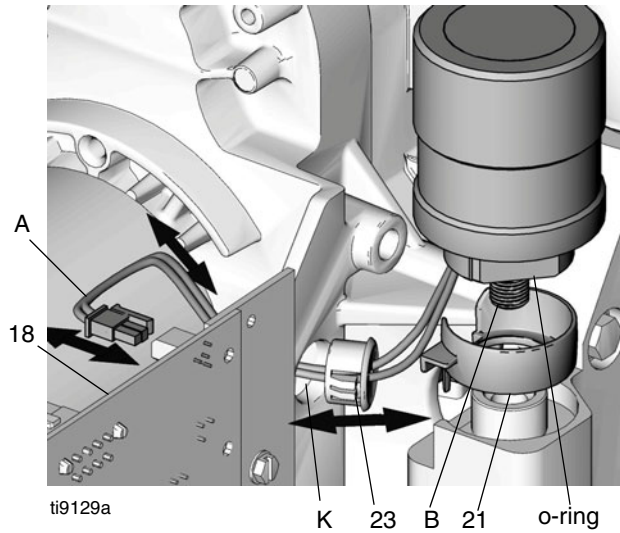

1. Inspect pressure control before installation to verify o-ring is installed.
2. Align pressure control wire cap (21) on fluid manifold so opening faces toward motor.

3. Apply loctite to pressure control knob (B) threads.
4. Screw pressure control threads (B) into manifold and torque to 150 in-lb (17.0 N.m).

NOTE: Be careful when tightening pressure control knob that wires are not pinched between pressure control and fluid manifold.

5. Tuck wires into pressure control wire cap (21) and route wires toward cap opening. Feed wires through housing hole (K).
6. Insert bushing (23) in hole (K).
7. Connect pressure switch connector (A) to control board (18).
8. Install shroud (12) and two screws (4) (**see illustration, page 17**).
9. **Hi-Boy Models Only** - Connect high-pressure hose at pump outlet (**see page 14**).

Drain Valve Replacement

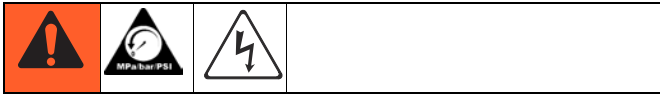

Removal

1. **Relieve pressure, page 7.** Disconnect power cord from outlet.
2. Remove pin (47) from drain valve handle (46).
3. Pull drain valve handle and valve base (45) from drain valve (44).
4. Unscrew drain valve from filter manifold (43).
5. Remove valve seat (44b) and seat gasket (44a) from inside of filter manifold or end of drain valve.

Installation

1. Install new seat gasket (44a) and valve seat (44b) on end of drain valve.
2. Screw drain valve (44) into filter manifold (43). Torque to 120 to 130 in-lb.
3. Push valve base (45) over drain valve (44) and then valve drain handle (46) over valve base.
4. Install pin (47) in drain valve handle. If necessary, use a hammer to tap pin in place completely.

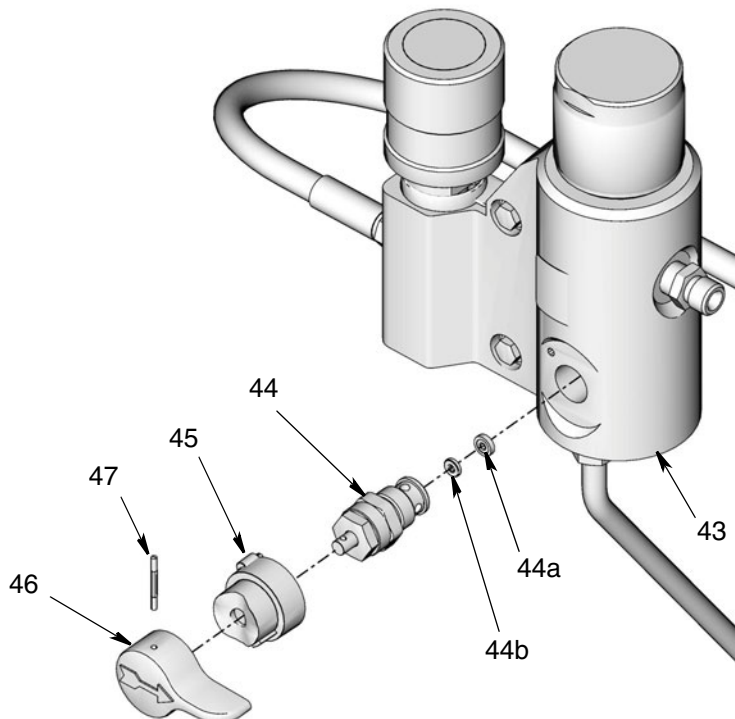

ti16090a

Drain Line Replacement

Removal

1. Cut drain line (49) from barbed fitting (51).
2. Unscrew barbed fitting from filter manifold (43).

NOTE: To reuse existing barbed fitting (51) and drain line (49), cut and remove remaining drain line material from end of barbed fitting.

Installation

1. Screw barbed fitting (51) into filter manifold (43).
2. Push drain line (49) onto barbed fitting.

NOTE: To make drain line more pliable and easier to install over barbed fitting, heat end of drain line (49) with a hair dryer or place end in hot water a few seconds.

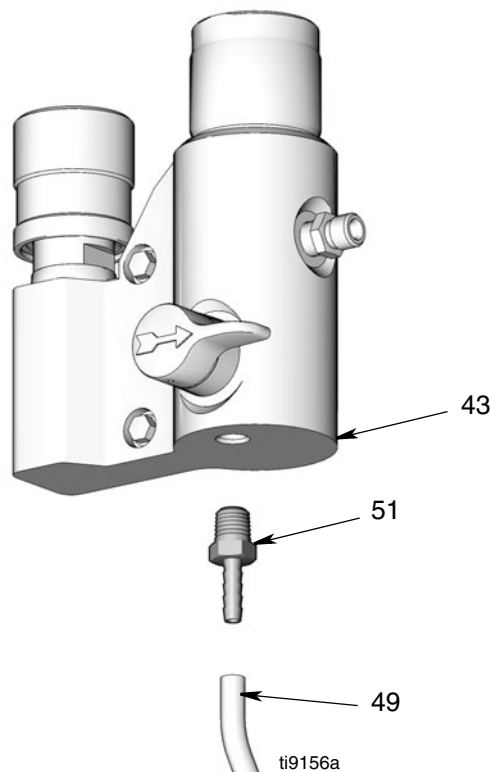

Power Cord Replacement

See *Wiring Diagram*, page 28.



Removal

1. Remove control board, **Control Board Replacement, Removal**, page 19.
2. Remove green ground screw (20) and disconnect green ground wire (G) from frame.

Installation

1. Connect green ground wire (G) to frame with green ground screw (20). Be sure green ground wire terminal faces up or wires could get caught in shroud.
2. Install control board, **Control Board Replacement, Installation**, page 20.

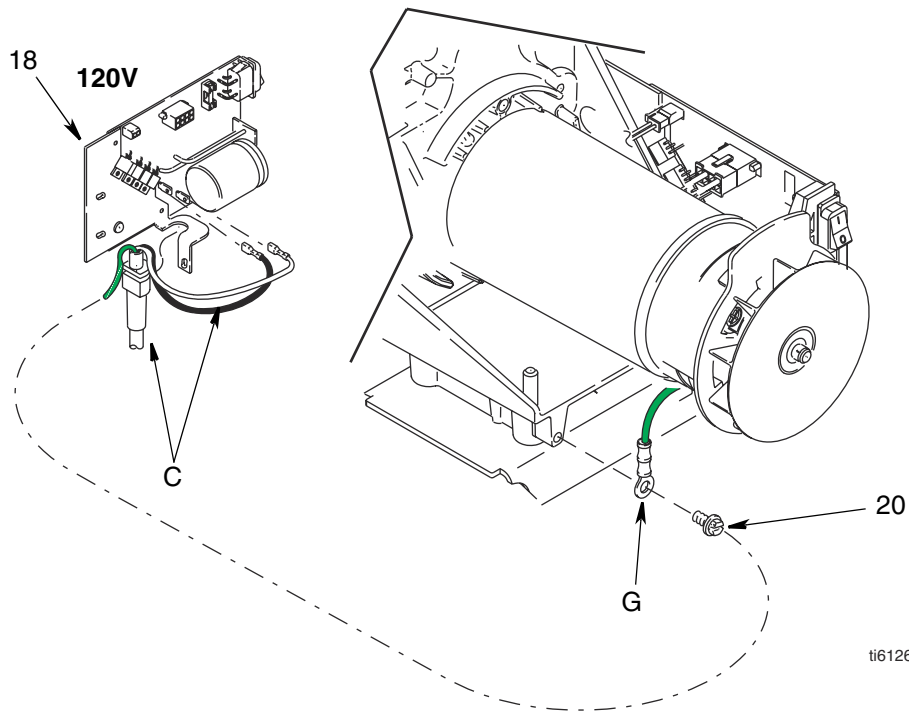

ti6126c

ti16091a

Motor Replacement

See Wiring Diagram, page 28.

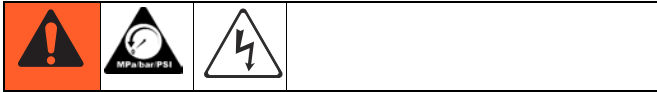

NOTICE

Do not drop gear cluster (27) and (26) when removing drive housing (29). Gear cluster may stay engaged in motor front end bell or drive housing.

Removal

1. **Relieve pressure, page 7.** Disconnect power cord from outlet.
2. **Hi-Boy Models Only** - Disconnect high-pressure hose at pump outlet (see page 13).
3. Remove pump, **Displacement Pump Replacement, page 13.**
4. Remove drive housing, **Drive Housing Replacement, page 15.**
5. Remove control board, **Control Board Replacement, page 19.**

6. Remove two screws (4) and filter manifold (43).
7. Remove green ground screw (20) and ground wire (G) from motor endbell.
8. Remove cover (14). Remove four screws (4) and motor (57) from frame (1).

Installation

1. Install cover (14) on motor (57). Install motor on frame (1) with four screws (4).
2. Connect green ground wire (G) to frame with green ground screw (20). Be sure green ground wire terminal faces up or wires could get caught in shroud. (see illustration, page 25.)
3. Install manifold (43) with two screws (4).
4. Install control board, **Control Board Replacement, page 19.**
5. Install drive housing. **Drive Housing Replacement, page 15.**
6. Install pump. **Displacement Pump Replacement, page 13.**

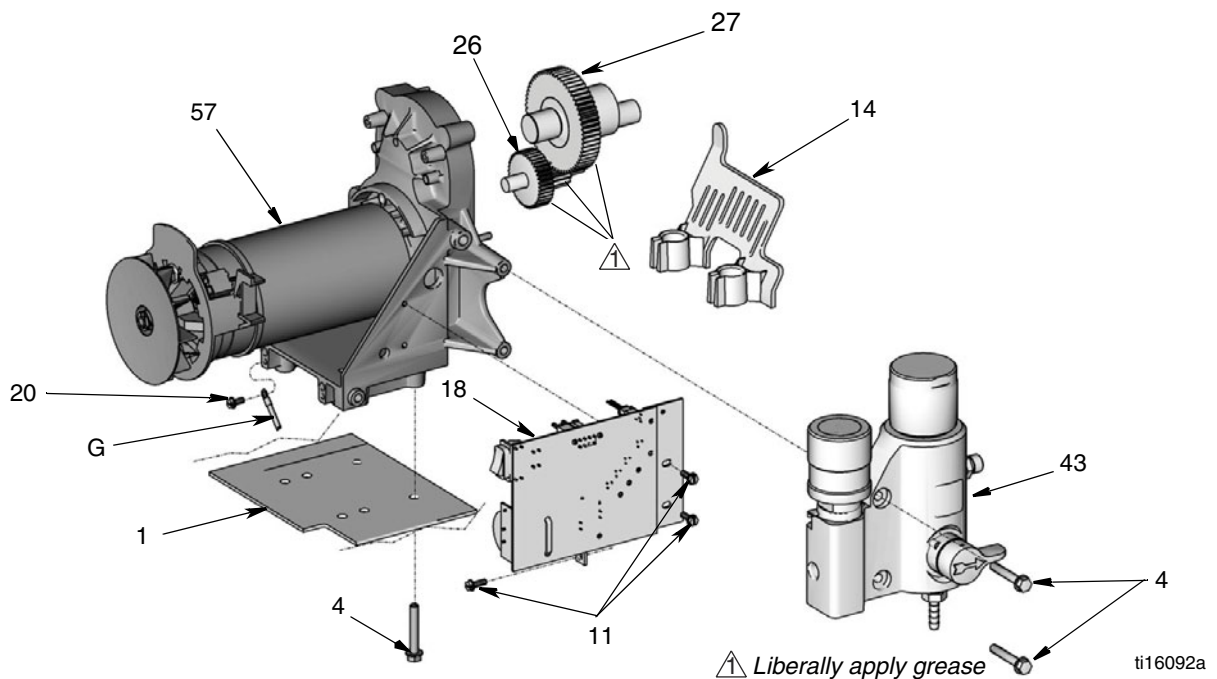

Wiring Diagrams

120V

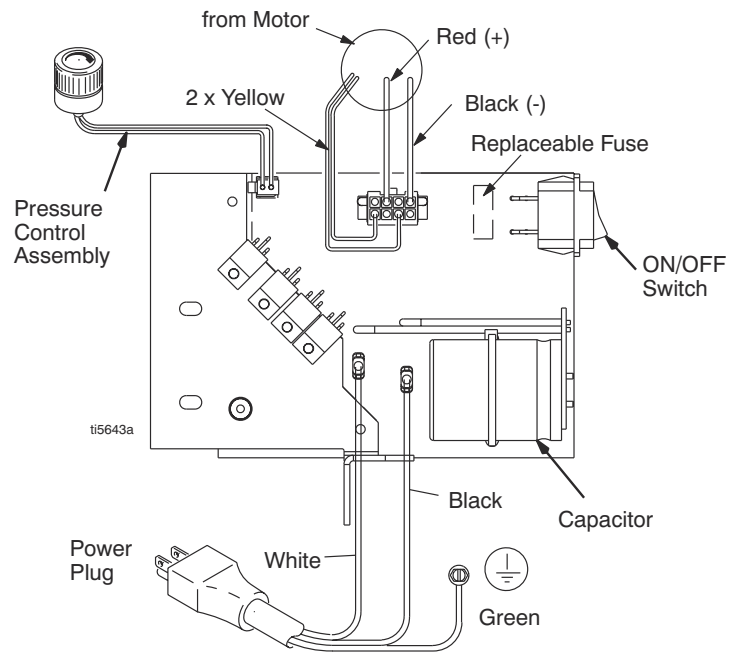

ti5643a1

Parts (Stand)

Models 24F561, 24F563

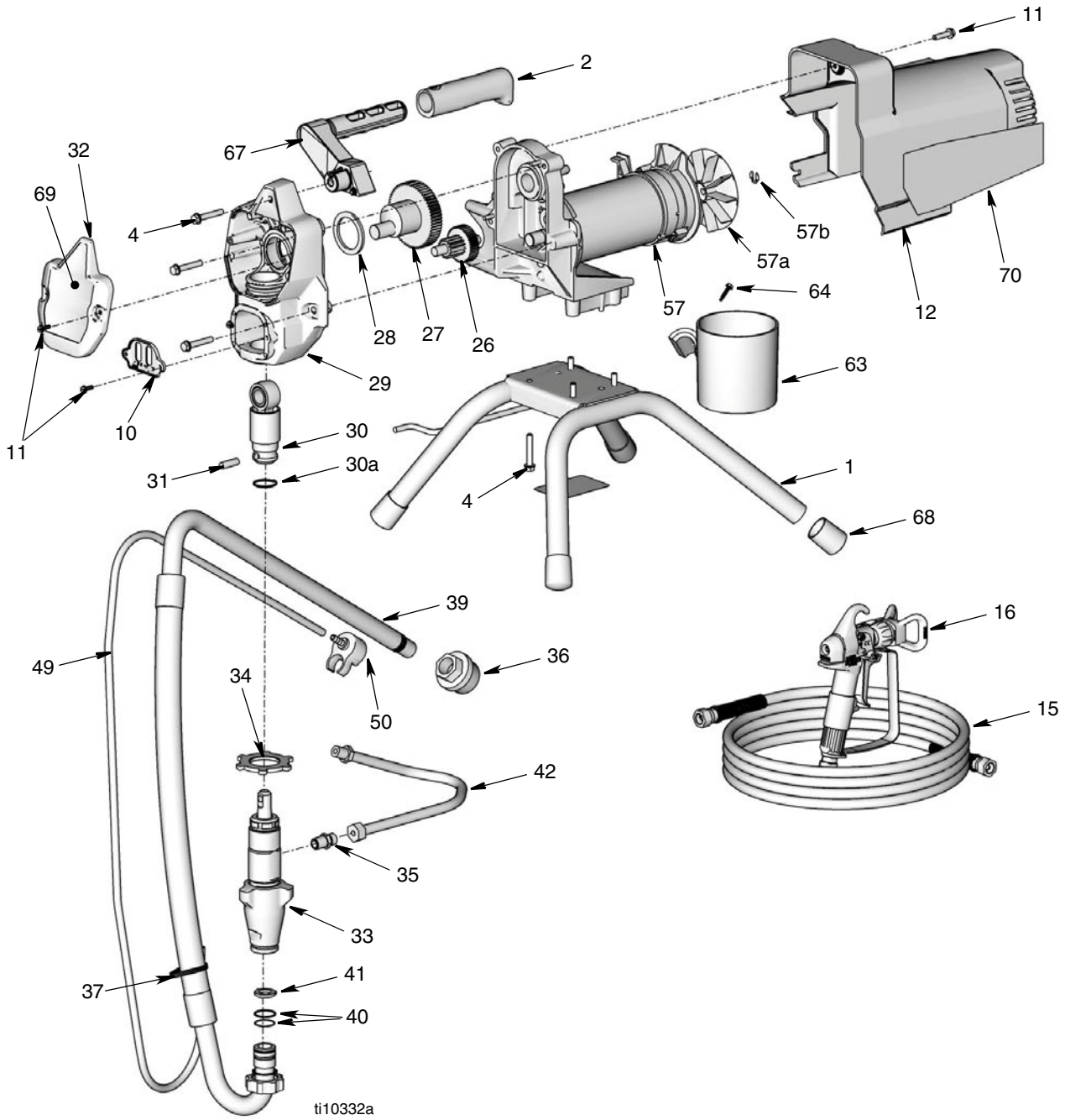

Parts List (Stand) Models 24F561, 24F563

Ref	Part	Description	Qty	Ref	Part	Description	Qty
1	15E823	FRAME, stand mount	1	35	162453	FITTING, (1/4 npsm x 1/4 npt)	2
2	116139	GRIP, handle	1	36	246385	STRAINER, 7/8-14 unf	1
3	119723	TAPE, foam	1	37	114958	STRAP, tie	1
4	117493	SCREW, mach, hex washer hd	11	39	246386	HOSE, suction set, includes 41, 40, 36	1
10	15B589	COVER, pump rod	1	40	117559	O-RING	2
11	117501	SCREW, machine, hex washer head	9	41	115099	WASHER, garden hose	1
12		KIT, shield, motor, includes 11, 71, 72, 70		42	15M670	HOSE, cpld	1
	255432	Model 24F561	1	49	249051	KIT, tube, drain, includes 51, 50, 37	1
	255433	Model 24F563	1	50	244035	DEFLECTOR, barbed	1
15	HSE1450	HOSE, cpld, 1/4 x 50 ft	1	57❖	255485	MOTOR, electric, includes 57a, 57b	1
16		GUN, spray	1	57a	249043	FAN, motor, includes 57b	1
	289316	Model 24F561	1	57b	119653	RING, retaining	1
	289283	Model 24F563	1	63	15G838	CUP, suction/drain	1
26	249194	GEAR, reducer	1	64	115723	SCREW, drill, hex washer head	1
27	249195	GEAR, crankshaft, includes 28	1	67	276864	HANDLE, includes 4, 2	1
28	180131	BEARING, thrust	1	68	112759	CAP, tubing	4
29	255488	HOUSING, drive, includes 4, 11, 10	1	69		LABEL, front	1
30	287053	ROD, connecting, includes 30a, 31	1		16F573	Model 24F561	1
30a	196750	SPRING, retaining	1		16F734	Model 24F563	1
31	196762	PIN, straight	1	70		LABEL, side	1
32	276883	COVER, front, includes 11, 69	1		16F599	Model 24F561	1
33	255475	PUMP, displacement, includes 35 (Manual 312362)	1		16F927	Model 24F563	1
34	195150	NUT, jam, pump	1	‡	119277	FUSE, replacement	
				❖	249042	KIT, brush, motor, replacement	

◆ Replacement Danger and Warning labels, tags, and cards are available at no cost.

‡ Other filters available: 245528, 100 mesh; 245526, 200 mesh.

Parts (Stand) Models 24F561, 24F563

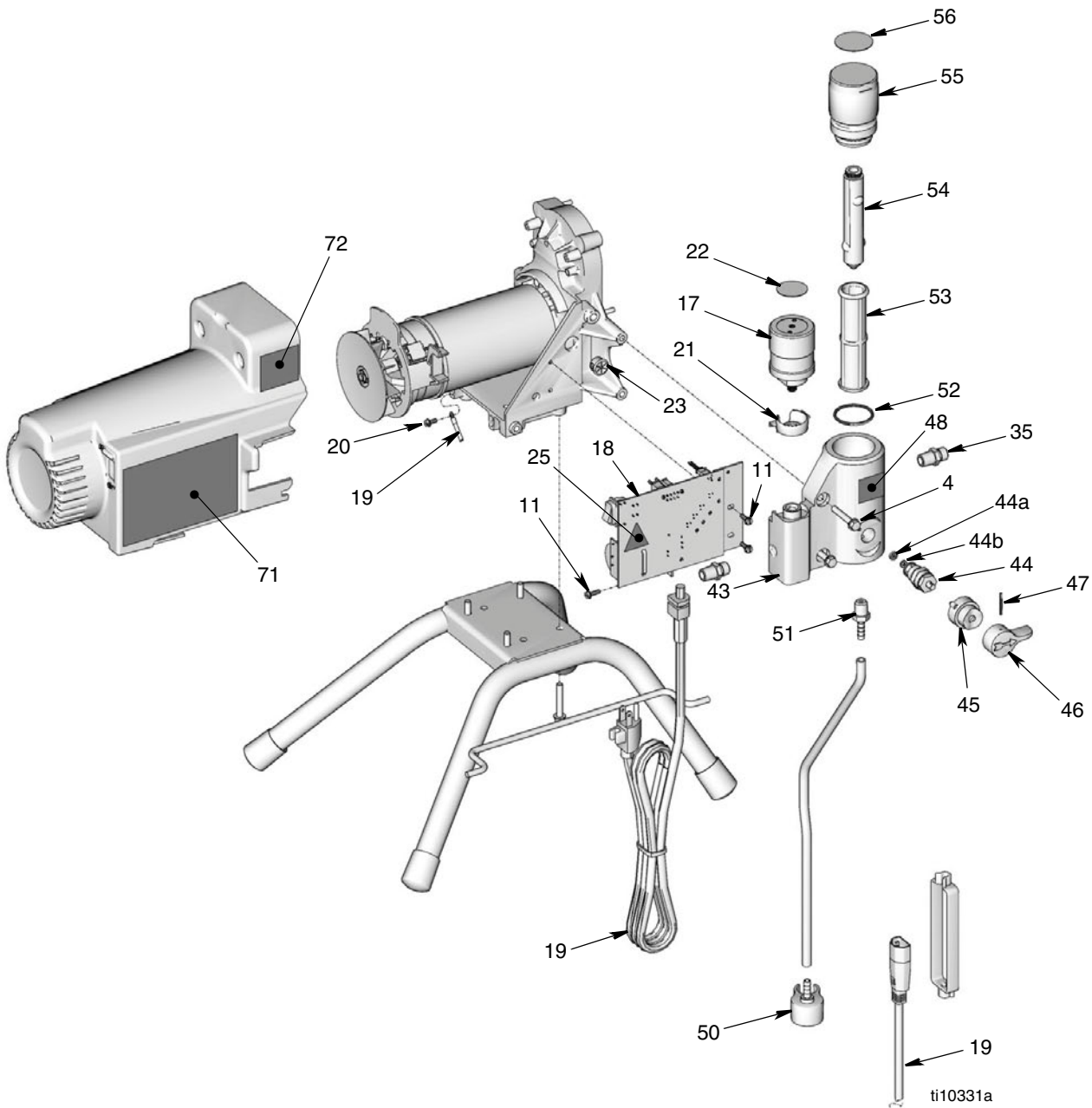

Parts List (Stand) Models 24F561, 24F563

Ref	Part	Description	Qty	Ref	Part	Description	Qty
4	117493	SCREW, mach, hex washer hd	11	45	224807	BASE, valve	1
11	117501	SCREW, machine, hex washer head	9	46	187625	HANDLE, valve, drain	1
17	249005	CONTROL, pressure, includes 21, 23, 03	1	47	111600	PIN, grooved	1
18‡	255483	CONTROL BOARD	1	48	195811	LABEL, instruction	1
19	15B119	CORD	1	50	244035	DEFLECTOR, barbed	1
20	115498	SCREW, mch, slot, hex, wash hd	1	51	M70809	FITTING	1
21	15E794	CAP, wire, control, pressure	1	52	104361	O-RING	1
22	15F399	LABEL, control	1	53†	245527	FILTER, fluid, 60 mesh	1
23	115756	BUSHING	1	54	15E288	INSERT, filter	1
25◆	189930	LABEL, caution	1	55	15E289	CAP, filter	1
35	162453	FITTING, (1/4 npsm x 1/4 npt)	2	56	195707	LABEL, identification	1
43	15J745	MANIFOLD, filter	1	71◆	15K359	LABEL, warning	1
44	235014	VALVE, drain, includes 44a, 44b	1	72◆	195833	LABEL, warning	1
44a	111699	GASKET, seat	1	‡	119277	FUSE, replacement	
44b	15E022	SEAT, valve	1	❖	249042	KIT, brush, motor, replacement	

◆ Replacement Danger and Warning labels, tags, and cards are available at no cost.

† Other filters available: 245528, 100 mesh; 245526, 200 mesh.

Parts (Hi-Boy) Models 24F562, 24F564

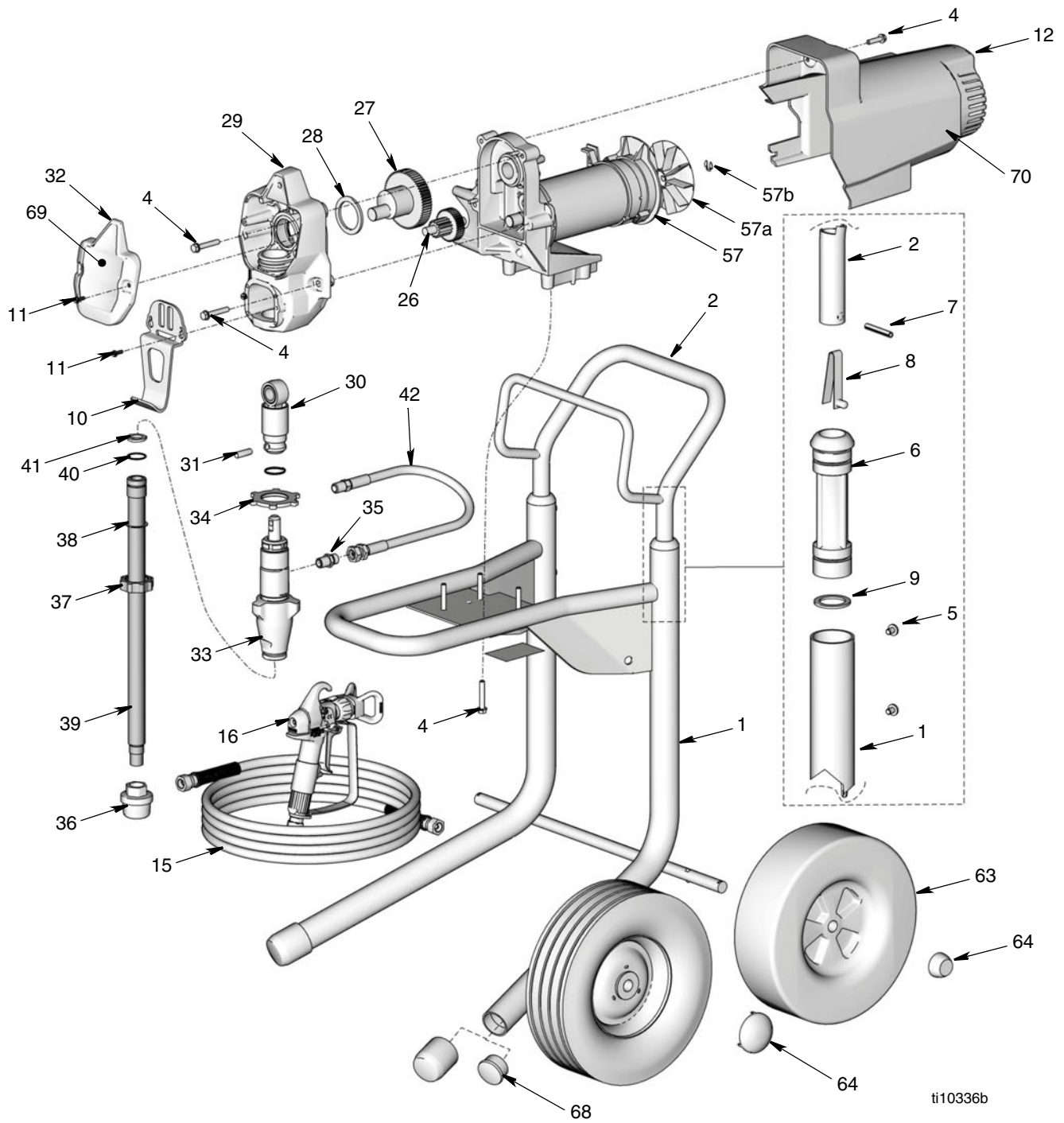

Parts List (Hi-Boy) Models 24F562, 24F564

Ref	Part	Description	Qty	Ref	Part	Description	Qty
1	288216	FRAME, cart, hi	1				
2	245245	HANDLE, cart	1	34	195150	NUT, jam, pump	1
4	117493	SCREW, mach, hex washer hd	10	35	162453	FITTING, (1/4 npsm x 1/4 npt)	2
5	109032	SCREW, mach, pnh	4	36	235004	STRAINER, 3/4-16 unf	1
6	192027	SLEEVE, cart	2	37	15E813	NUT, jam	1
7	101354	PIN, spring straight	2	38	15B652	WASHER, suction	1
8	111590	BUTTON, snap	2	39	15J801	TUBE, suction, intake	1
9	15J645	WASHER	2	40	103413	O-RING	1
10	15J812	HANGER, pail	1	41	115099	WASHER, garden hose	1
11	117501	SCREW, mach, slot hex wash hd	7	42	15M671	HOSE, cpld	1
12		KIT, shield, motor (includes 4, 70, 71, 72)		57❖	255485	MOTOR, electric (includes 57a, 57b)	
	255434	Models 24F562	1	57a	249043	FAN, motor	1
	255435	Model 24F564	1	57b	119653	RING, retaining	1
15	HSE1450	HOSE, cpld, 1/4 in. x 50 ft	1	63	119451	WHEEL, semi pneumatic	2
16		GUN, spray	1	64	119452	CAP, hub	2
	289316	Model 24F564	1	68	15C871	CAP, leg	2
	289283	Model 24F563		69		LABEL, front, brand	
26	249194	GEAR, assembly, combination	1		16F573	Models 24F562	1
27	249195	GEAR, crankshaft; includes 28	1		16F734	Models 24F564	1
28	180131	BEARING, thrust	1	70		LABEL, side, brand	
29	255487	HOUSING, drive; includes 4, 10, 11	1		16F599	Models 24F562	1
					16F927	Model 24F564	1
30	287053	ROD, connecting; includes 30a, 31	1	78	245651	FLUID, TSL, 8 oz (not shown)	1
30a	196750	SPRING, retaining	1			◆ Warning labels are available free of charge	
31	196762	PIN, straight	1			❖ 249042 KIT, brush, motor	
32	276883	COVER, front	1				
33	255475	PUMP, displacement; includes 35 Manual 312362	1				

Parts (Hi-Boy) Models 24F562, 24F564

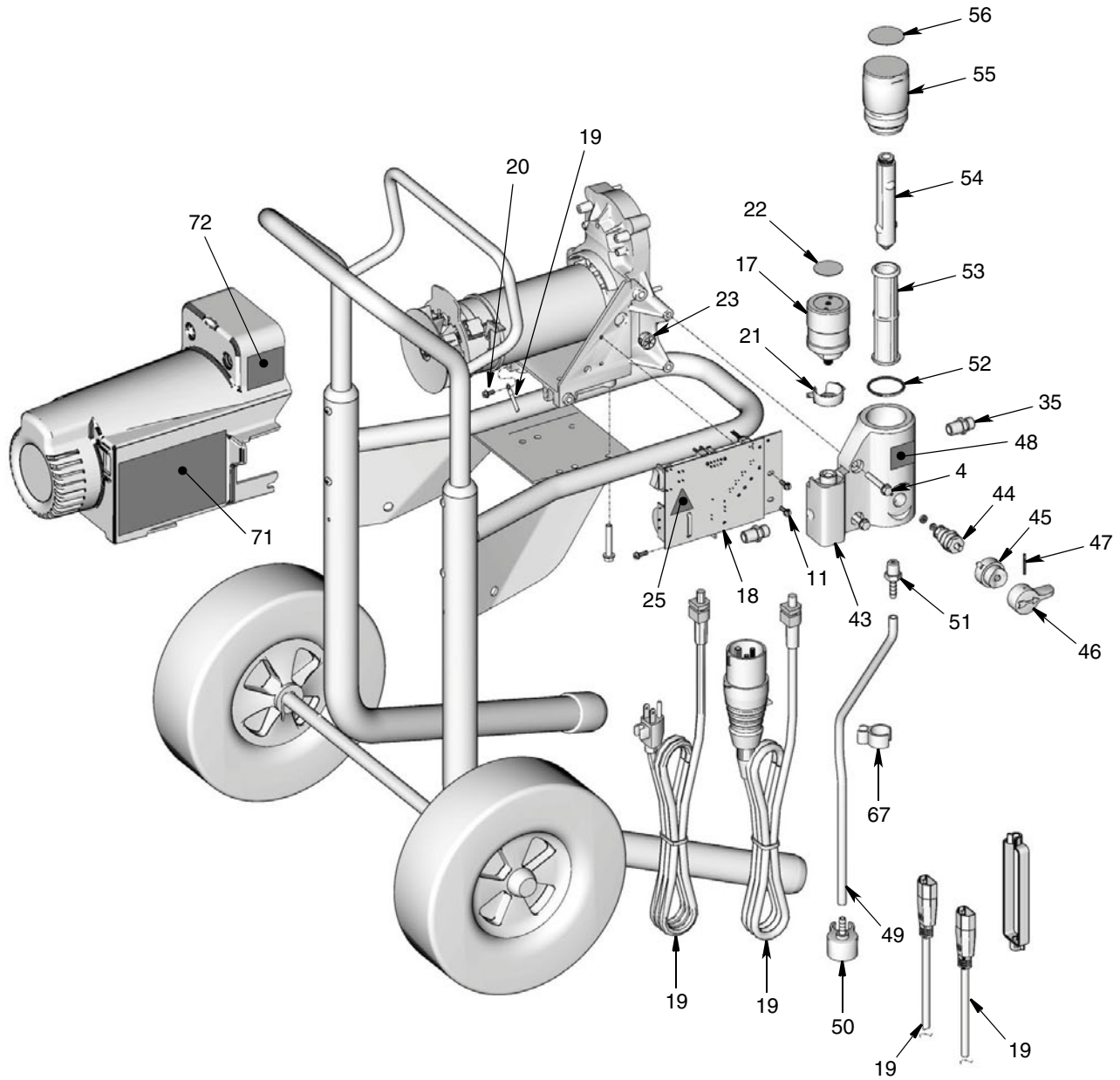

Parts List (Hi-Boy) Models 24F562, 24F564

Ref	Part	Description	Qty	Ref	Part	Description	Qty
4	117493	SCREW, mach, hex washer hd	10	48	195811	LABEL, instruction	1
11	117501	SCREW, mach, slot hex wash hd	7	49	15K092	TUBE, drain	1
17	249005	CONTROL, pressure (includes 21, 22, 23)	1	50	244035	DEFLECTOR, barbed	1
18‡	255483	CONTROL BOARD	1	51	M70809	FITTING, barbed, hose	1
19	15B119	CORD, power	1	52	104361	O-RING	1
20	115498	SCREW, mach, slot hex wash hd	1	53†	245527	FILTER, fluid, 60 mesh	1
21	15E794	CAP, wire, control, pressure	1	54	15E288	INSERT, manifold	1
22	15F399	LABEL, pressure control knob	1	55	15E289	CAP, filter	1
23	115756	BUSHING, universal	1	56	195707	LABEL, identification	1
25	189930	LABEL, caution	1	67	195400	CLIP, spring	1
43	15J745	MANIFOLD, Filter, 190/210 ES	1	71◆	15K359	LABEL, warning	1
44	235014	VALVE, drain; includes 44a, 44b	1	72◆	195833	LABEL, warning	1
44a	111699	GASKET, seat	1				
44b	15E022	SEAT, valve	1				
45	224807	BASE, valve	1				
46	187625	HANDLE, valve, drain	1				
47	111600	PIN, grooved	1				

◆Warning labels are available free of charge

‡ 119277 Fuse replacement

† Other filters available: 245528, 100 mesh; 245526, 200 mesh.

Technical Data

Power requirements	100/120V AC, 50/60 hz, 11A, 1 phase
Generator required	3000 w minimum
Maximum working pressure	3300 psi (22.7 MPa, 227 bar)
Cycles per gallon (liter)	680 (180)
Maximum delivery gpm (lpm)	0.47 (1.8)
Maximum tip size	0.021
Fluid outlet npsm	1/4 in.
Dimensions (Stand): 24F561, 24F563	
Length	15.75 in. (40.0 cm)
Width	14.0 in. (36.0 cm)
Height	17 in. (43 cm)
Weight	30 lb (13.6 kg)
Weight (with gauge)	31 lb (14.0 kg)
Dimensions (Hi-Boy): 24F562, 24F564	
Length	22.0 in. (55.9 cm)
Width	20.5 in. (52.1 cm)
Height	38.8 in. (98.6 cm)
Weight	59.0 lb (26.8 kg)
Weight (with gauge)	60.0 lb (27.2 kg)
Wetted parts	zinc and nickel-plated carbon steel, nylon, stainless steel, PTFE, acetal, leather, UHMWPE, aluminum, tungsten carbide
Noise level*	
Sound power (ISO 3744)	100dBa*
Sound pressure (ISO 3744)	90 dBa*
*Measured 3 feet (1 meter) from equipment.	

Airlessco Standard Warranty

Airlessco warrants all equipment referenced in this document which is manufactured by Airlessco and bearing its name to be free from defects in material and workmanship on the date of sale to the original purchaser for use. With the exception of any special, extended, or limited warranty published by Airlessco, Airlessco will, for a period of twelve months from the date of sale, repair or replace any part of the equipment determined by Airlessco to be defective. This warranty applies only when the equipment is installed, operated and maintained in accordance with Airlessco's written recommendations.

This warranty does not cover, and Airlessco shall not be liable for general wear and tear, or any malfunction, damage or wear caused by faulty installation, misapplication, abrasion, corrosion, inadequate or improper maintenance, negligence, accident, tampering, or substitution of non-Airlessco component parts. Nor shall Airlessco be liable for malfunction, damage or wear caused by the incompatibility of Airlessco equipment with structures, accessories, equipment or materials not supplied by Airlessco, or the improper design, manufacture, installation, operation or maintenance of structures, accessories, equipment or materials not supplied by Airlessco.

This warranty is conditioned upon the prepaid return of the equipment claimed to be defective to an authorized Airlessco distributor for verification of the claimed defect. If the claimed defect is verified, Airlessco will repair or replace free of charge any defective parts. The equipment will be returned to the original purchaser transportation prepaid. If inspection of the equipment does not disclose any defect in material or workmanship, repairs will be made at a reasonable charge, which charges may include the costs of parts, labor, and transportation.

THIS WARRANTY IS EXCLUSIVE, AND IS IN LIEU OF ANY OTHER WARRANTIES, EXPRESS OR IMPLIED, INCLUDING BUT NOT LIMITED TO WARRANTY OF MERCHANTABILITY OR WARRANTY OF FITNESS FOR A PARTICULAR PURPOSE.

Airlessco's sole obligation and buyer's sole remedy for any breach of warranty shall be as set forth above. The buyer agrees that no other remedy (including, but not limited to, incidental or consequential damages for lost profits, lost sales, injury to person or property, or any other incidental or consequential loss) shall be available. Any action for breach of warranty must be brought within two (2) years of the date of sale.

AIRLESSCO MAKES NO WARRANTY, AND DISCLAIMS ALL IMPLIED WARRANTIES OF MERCHANTABILITY AND FITNESS FOR A PARTICULAR PURPOSE, IN CONNECTION WITH ACCESSORIES, EQUIPMENT, MATERIALS OR COMPONENTS SOLD BUT NOT MANUFACTURED BY Airlessco. These items sold, but not manufactured by Airlessco (such as electric motors, switches, hose, etc.), are subject to the warranty, if any, of their manufacturer. Airlessco will provide purchaser with reasonable assistance in making any claim for breach of these warranties.

In no event will Airlessco be liable for indirect, incidental, special or consequential damages resulting from Airlessco supplying equipment hereunder, or the furnishing, performance, or use of any products or other goods sold hereto, whether due to a breach of contract, breach of warranty, the negligence of Airlessco, or otherwise.

FOR AIRLESSCO CANADA CUSTOMERS

The Parties acknowledge that they have required that the present document, as well as all documents, notices and legal proceedings entered into, given or instituted pursuant hereto or relating directly or indirectly hereto, be drawn up in English. Les parties reconnaissent avoir convenu que la rédaction du présente document sera en Anglais, ainsi que tous documents, avis et procédures judiciaires exécutés, donnés ou intentés, à la suite de ou en rapport, directement ou indirectement, avec les procédures concernées.

TO PLACE AN ORDER OR FOR SERVICE, contact your Airlessco distributor,
or call 1-800-223-8213 to identify the nearest distributor.

*All written and visual data contained in this document reflects the latest product information available at the time of publication.
Airlessco reserves the right to make changes at any time without notice.*

Original Instructions. This manual contains English. *MM3A1181*
Airlessco, 3501 N. 4th Avenue, Sioux Falls, SD 57104
www.airlessco.com
10/2010