

KEEP FOR REFERENCE.
Read this and all related manuals for important warnings and instructions.

INSTRUCTIONS

Ultra Max™ 695/795/1095 Airless Paint Sprayers

3300 psi (227 bar, 22.7 MPa) Maximum Working Pressure

220–240 VAC

Sprayer	Series	Lo-boy	Hi-boy	Parts
695	B	245005	245004 245009	309253
795	A	245025	245024 245027	309261
1095	A		245034 245038	309261

100–120 VAC (U.K., Japan, Taiwan)

Sprayer	Series	Lo-boy	Hi-boy	Parts
695	B	245008	245006 245007	309253
795	A		245026	309261
1095	A	245037	254035 245036	309261

120 VAC (North America)

Sprayer	Series	Lo-boy	Hi-boy	Parts
695	B	245002	245000	309252
	A	245003 245011 245051 246309	245001 245010 245050 246308	
795	A	245022 245023	245020 245021 245028	309260
1095	A		245030 245031 245032 245039	309260

Related manuals



..... 309257

Operation



..... 309250 (695)
..... 309277 (795/1095)

Pump



North America **Global**

..... 309252 309253 (695)
..... 309260 309261 (795/1095)

Parts



..... 309639

Spray Gun



..... 309640

Spray Tip

Table of Contents

Warnings	2	Pressure Control Repair	16
Component Function and Identification	3	Drive Housing Replacement	20
General Repair Information	4	Motor Replacement	22
Grounding	5	Displacement Pump Replacement	23
Troubleshooting	5	Technical Data	24
Spin Test	9	Graco Phone Number	24
Motor Brush Replacement	9	Graco Warranty	24
On/Off Switch Replacement	13		

⚠ WARNING

Fire and explosion hazard: Solvent and paint fumes can ignite or explode.

To help prevent a fire and explosion:

- Use only in an extremely well ventilated area.
- Eliminate all ignition sources; such as pilot lights, cigarettes and plastic drop cloths (static arc hazard). Do not plug or unplug power cords or turn lights on or off in spray area.
- Ground Sprayer, object being sprayed, paint and solvent pails.
- Hold gun firmly to side of grounded pail when triggering into pail.
- Use only conductive airless paint hose.
- Do not use 1,1,1-trichloroethane, methylene chloride, other halogenated hydrocarbon solvents or fluids containing such solvents in pressurized aluminum equipment. Such use could result in a chemical reaction, with the possibility of explosion.
- To reduce risk of electric shock, use grounded outlet only. Shut OFF and unplug when repairing.

Fluid injection and high pressure hazard: High pressure spray or leaks can inject fluid into the body.

To help prevent injection, always:

- Engage trigger safety latch when not spraying.
- Keep clear of nozzle and leaks.
- Never spray without a tip guard.
- Do **PRESSURE RELIEF** if you stop spraying or begin servicing sprayer.
- Do not use components rated less than sprayer *Maximum Working Pressure*.
- Never allow children to use this unit.

If high pressure fluid pierces your skin, the injury might look like "just a cut". But it is a serious wound! Get immediate medical attention.



⚠ ADVERTÊNCIA

Perigo de incêndio e explosão: os solventes e os vapores da pintura poderão explodir ou incendiar.

Para ajudar a evitar incêndio e explosão:

- Utilize unicamente em áreas extremamente bem ventiladas.
- Elimine todas as fontes de ignição, tais como luzes piloto, cigarros e arcos de estática resultantes dos plásticos de proteção. Não ligue nem desligue os cabos de alimentação ou as luzes numa área de pulverização.
- Ponha em contato com a terra o pulverizador, o objeto a ser pulverizado, e os baldes de tinta e de solventes.
- Segure a pistola firmemente de encontro ao lado do balde em contato com a terra, quando estiver descarregando para dentro do mesmo.
- Utilize somente tubos flexíveis condutores para pintura a alta pressão.
- Não utilize 1,1,1-tricloroetano, cloro de metileno, outros solventes de hidrocarbonetos halogenados ou líquidos contendo tais solventes em equipamento de alumínio pressurizado. Tal utilização poderá resultar numa reação química, com possibilidade de explosão.
- Para reduzir o risco de choque elétrico, use a tomada aterrada somente. Feche FORA e desconecte ao reparar.

Perigo de injeção de líquidos à alta pressão: a pulverização ou vazamentos à alta pressão podem injetar líquido no corpo.

Para ajudar a evitar injeção de líquido, faça sempre o seguinte:

- Engate o trinco de segurança do gatilho quando não estiver pulverizando.
- Mantenha-se afastado dos bocais e locais onde há vazamentos.
- Nunca pulverize sem que haja uma proteção na extremidade.
- **ALIVIE A PRESSÃO** quando parar de pulverizar e antes de iniciar a manutenção do pulverizador.
- Não utilize componentes com uma classificação inferior à do pulverizador *Pressão Máxima de Trabalho*.
- Nunca permita que crianças utilizem esta unidade.

Se o líquido a alta pressão penetrar na sua pele, o ferimento poderá parecer "simplesmente um corte". Mas é um ferimento grave! Procure o médico imediatamente.

⚠ MISE EN GARDE

Danger d'incendie et d'explosion : les gaz de solvant et de peinture peuvent s'enflammer ou exploser.

Pour éviter les risques d'incendie et d'explosion :

- N'utiliser l'appareil que dans une zone extrêmement bien aérée.
- Éliminer toute source d'inflammation ; telle que veilleuses, cigarettes et arcs d'électricité statique créés par les toiles de peintre en plastique. Ne pas brancher et débrancher de cordons électriques, ou allumer et éteindre des lumières dans la zone de pulvérisation.
- Mettre à la terre le pulvérisateur, l'objet à pulvériser ainsi que les seaux de peinture et de solvants.
- Tenir le pistolet fermement contre la paroi d'un seau mis à la terre lorsqu'on pulvérise dans le seau.
- N'utiliser qu'un flexible pour peinture pulvérisée sans air.
- Ne jamais utiliser de trichloroéthane 1,1,1, de chlorure de méthylène, d'autres solvants à base d'hydrocarbures halogénés, ni de produits contenant de tels solvants dans un équipement sous pression en aluminium. Cela pourrait provoquer une réaction chimique avec risque d'explosion.
- Pour réduire le risque de décharge électrique, employez la sortie au sol seulement. Coupez et débranchez quand la réparation.

Danger d'injection de fluide et haute pression : la pulvérisation sous haute pression ou les fuites peuvent injecter des fluides dans le corps.

Pour éviter les risques d'injection, toujours :

- Bloquer le loquet de sécurité de la gâchette à la fin de la pulvérisation.
- Se tenir loin de la buse et des fuites.
- Ne jamais pulvériser sans anti-gouttes.
- **DÉCHARGER LA PRESSÃO** à la fin de la pulvérisation ou avant de réparer le pulvérisateur.
- Ne pas utiliser de composants dont la pression nominale est inférieure à la *pression maximale de service du système*.
- Ne jamais permettre aux enfants d'utiliser cet appareil.

Si un fluide haute pression perce la peau, la blessure peut paraître une "simple coupure" Mais il s'agit bien d'une lésion grave! Consulter immédiatement un médecin.

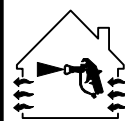

⚠ ADVERTENCIA

Peligro de incendio o explosión: Los gases de los disolventes y de la pintura pueden inflamarse o provocar una explosión.

Para prevenir incendios y explosiones:

- Use únicamente en un área muy bien ventilada.
- Suprima todas las fuentes de ignición; como luces piloto, cigarrillos y arcos estáticos de carpetas plásticas para protección contra pintura. No enchufe ni desenchufe cables de alimentación ni apague ni encienda las luces en un área de pulverización.
- Ponga a tierra el pulverizador, el objeto que recibe el chorro pulverizado, las cubetas de pintura y disolvente.
- Sostenga firmemente la pistola a un lado de la cubeta puesta a tierra cuando dispare dentro de ella.
- Use solamente mangueras para pintura conductora sin aire.
- No utilice nunca tricloroetano-1,1,1, cloruro de metileno ni otros disolventes a base de hidrocarburos halógenos o fluidos que contengan dichos disolventes en un equipo a presión de aluminio. El uso de estas sustancias puede provocar una intensa reacción química, con riesgos de explosión.
- Para reducir el riesgo de la descarga eléctrica, utilice el enchufe puesto a tierra solamente. Apague y desenchufe al reparar.

Peligro de inyección de fluido y alta presión: por la pulverización o las filtraciones a alta presión se pueden inyectar fluidos en el organismo.

Para prevenir la inyección en la piel, siempre:

- Enganche el seguro del gatillo cuando no use el pulverizador.
- No se acerque a la boquilla ni a las filtraciones.
- Nunca aplique fluido pulverizado sin un guardaboquilla.
- Realice el **ALIVIO DE PRESSÃO** si deja de pulverizar fluido o repara el pulverizador.
- No use componentes de capacidad nominal inferior a la *presión máxima de operación del pulverizador*.
- No permita que niños usen esta unidad.

Si fluido de alta presión le penetra la piel, la lesión podría parecer "sólo un corte". ¡Es una lesión seria! Consulte de inmediato al médico.

Component Identification and Function

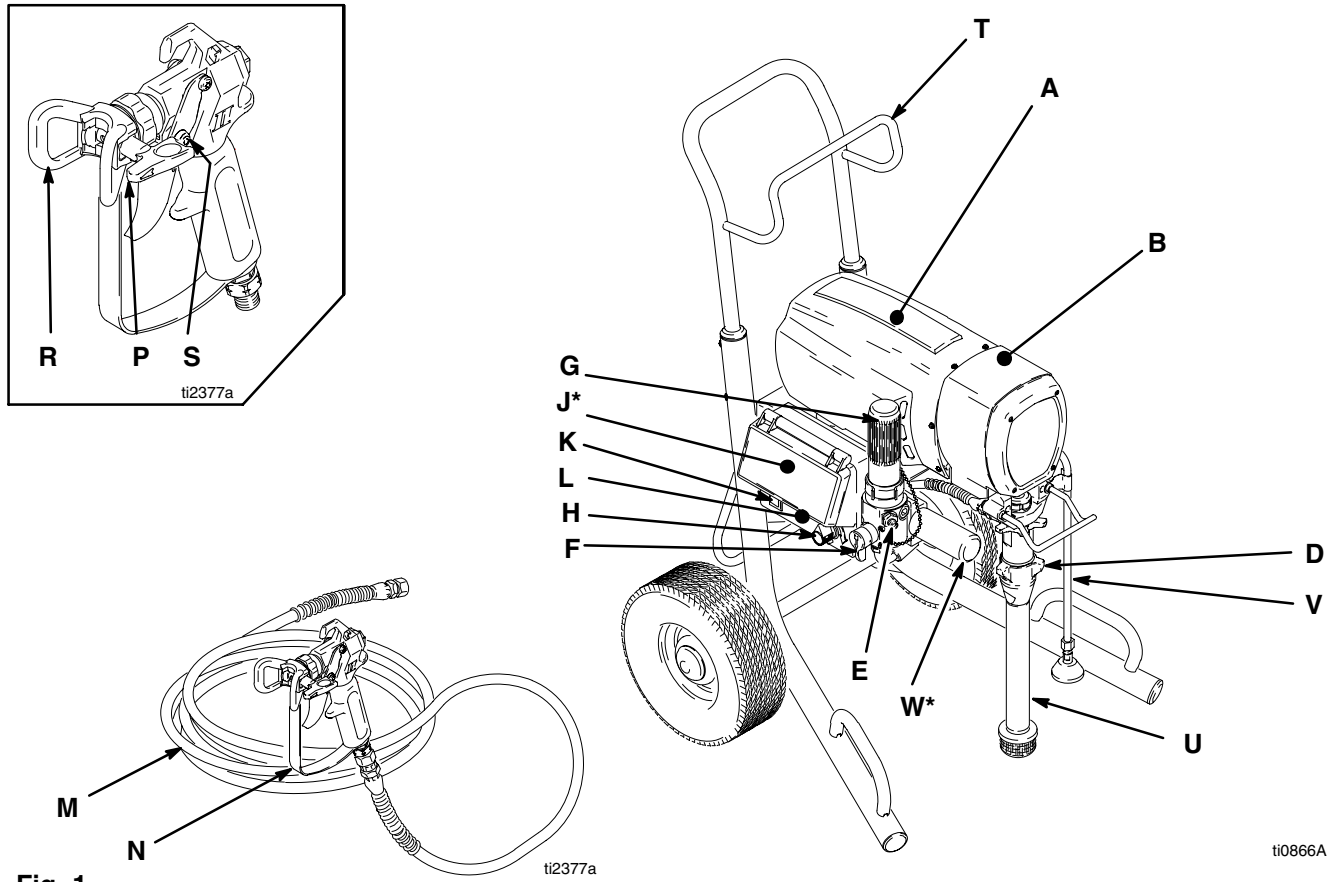

Fig. 1

A	Motor	DC motor, permanent magnet, totally enclosed, fan cooled
B	Drive Assembly	Transfers power from DC motor to displacement pump
D	Displacement Pump	Transfers fluid to be sprayed from source through spray gun
E	Fluid Outlet	Spray gun is connected here
F	Prime Valve	Used to prime, drain and flush sprayer when open
G	Fluid Filter	Final filter of fluid to spray gun
H	Pressure Adjusting Knob	Controls fluid outlet pressure
J*	Pressure Control/Display	Controls motor speed to maintain fluid outlet pressure. Works with pressure adjusting knob. Displays pressure, gallons/liters, flush time and error codes.
K	ON/OFF Switch	Power switch that controls main power to sprayer
L	15/20A or 10/12A Switch	Set to lower Amperage if circuit breaker trips when spraying (not all models)
M	Airless Paint Spray Hose	Grounded, conductive, nylon hose with spring guards on both ends
N	Spray Gun	High pressure spray gun with gun safety latch
P	RAC X SwitchTip	Uses high pressure fluid to clear tip clogs without removing tip from spray gun
R	HandTite™ Tip Guard	Tip guard reduces risk of injection injury
S	Gun Safety Latch	Gun safety latch inhibits accidental triggering of spray gun
T	Power Cord & Hose Rack	Holds wrapped power cord and paint hose for storage
U	Suction Tube	Transfers fluid to be sprayed from source to pump
V	Drain Tube	Fluid outlet used to drain and prime the sprayer
W*	AutoClean™ valve	Spray gun connection for timed back-flush of sprayer with automatic shut off
*	Not available on all sprayers	

General Repair Information

Pressure Relief Procedure

WARNING



INJECTION HAZARD

System pressure must be manually relieved to prevent system from starting or spraying accidentally. Fluid under high pressure can be injected through skin and cause serious injury. To reduce risk of injury from injection, splashing fluid, or moving parts, follow **Pressure Relief Procedure** whenever you:

- are instructed to relieve pressure,
- stop spraying,
- check or service any system equipment,
- or install or clean spray tip.

1. Lock gun safety latch.
2. Turn ON/OFF switch to OFF and pressure control knob to zero.
3. Unplug power supply cord.
4. Unlock gun safety latch. Hold metal part of gun firmly to grounded metal pail. Trigger gun to relieve pressure.
5. Lock gun safety latch.
6. Open pressure drain valve. Leave pressure drain valve open until ready to spray again.

If suspected that spray tip or hose is completely clogged, or that pressure has not been fully relieved after following steps above, VERY SLOWLY loosen tip guard retaining nut or hose end coupling to relieve pressure gradually, then loosen completely. Now clear tip or hose obstruction.

WARNING



ELECTRIC SHOCK HAZARD MOVING PARTS HAZARD

To reduce risk of serious injury, including electric shock, do not touch moving or electrical parts with fingers or tools while testing repair. Shut off and unplug sprayer when repairing. Install all covers, gaskets, screws and washers before operating sprayer.



CAUTION

To reduce risk of pressure control malfunction:

- Use needle nose pliers to disconnect wires. Never pull on wire, pull on connector.
- Mate wire connectors properly. Center flat blade of insulated male connector in female connector.
- Route wires carefully to avoid interference with other connections of pressure control. Do not pinch wires between cover and control box.

1. **Keep all screws, nuts, washers, gaskets, and electrical fittings** removed during repair procedures. These parts are not normally provided with replacement assemblies.
2. **Test repair** after problem is corrected.
3. **If sprayer does not operate properly**, review repair procedure to verify procedure was done correctly. If necessary, see Troubleshooting Guide, pages 5 – 8, for other possible solutions.

WARNING



HOT SURFACES HAZARD EXPLOSION HAZARD

Motor may be very hot during operation and could burn skin if touched.

Flammable materials spilled on hot, bare motor could cause fire or explosion.



Have motor shroud in place during operation to reduce risk of burns, fire or explosion.

4. **Install motor shroud before operation** of sprayer and replace if damaged. Motor shroud directs cooling air around motor to prevent overheating. It can also reduce risk of burns, fire or explosion; see preceding **WARNING**.

Grounding

⚠ WARNING

Improper installation or alteration of grounding plug results in risk of electric shock, fire or explosion that could cause serious injury or death.

1. All models require a grounded outlet for power connection. Circuit must be 50/60 Hz with an Ampere rating equal to or greater than the sprayer. See Fig. 2.
2. Do not alter ground prong or use adapter.

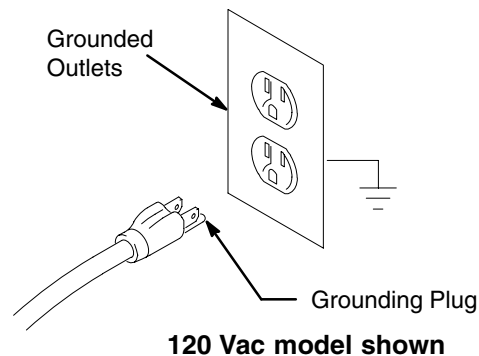

Fig. 2

3. 120 Vac: A 12 AWG, 3 wires with grounding prong, 300 ft (90 m) extension cord may be used.
220–240 Vac: You may use a 3-wire, 1.0 mm (12 AWG) (minimum) extension cord up to 90 m long. Long lengths reduce sprayer performance.

Troubleshooting



Relieve pressure; page 4.

PROBLEM	WHAT TO CHECK <i>If check is OK, go to next check</i>	WHAT TO DO <i>When check is not OK refer to this column</i>
Motor won't operate	1. Check digital display for error codes on sprayers with digital displays or motor control board inside SmartControl for blinking LED on sprayers without digital displays	1. If an error code (E=0X) is displayed or LED is blinking, go to page 18 for error code diagnostics. If not continue.
	2. Make sure digital display is connected. If nothing is displayed, check power cord, power switch and all power connections for continuity. Check building circuit power.	2. Tighten any loose power connections. Replace power switch, power cord or extension cords if damaged. Reset circuit breaker if tripped.
	3. Check pressure control knob setting. Motor will not run if pressure control knob is at minimum setting.	3. Increase pressure setting
	4. With drain valve open and pressure control knob set to maximum, check if there is a light blinking next to either psi , bar , or MPa <ol style="list-style-type: none"> a. If light is blinking, control board is commanding motor to run and problem is most likely motor or motor wiring. b. If light is not blinking, control board, control board wiring, potentiometer or transducer is most likely cause. 	4. Based on results of this test, investigate for possible wiring, motor, control, transducer or potentiometer problems in the following steps

Troubleshooting

PROBLEM	WHAT TO CHECK <i>If check is OK, go to next check</i>	WHAT TO DO <i>When check is not OK refer to this column</i>
Motor	1. Connections at control board and brushes	1. Repair any loose connections
	2. Brushes worn. Length must be 1/2 in. minimum. Check both sides.	2. Replace brushes. Page 9.
	3. Broken or misaligned brush springs	3. Realign or replace springs
	4. Brushes or springs binding in brush holder	4. Clean brush holder and align brush leads for free movement
	5. Check for armature short using an armature tester (growler) or perform spin test. Page 9.	5. Replace motor
	6. Check motor armature commutator for burn spots or other damage	6. Remove motor and have motor shop resurface commutator if possible. Page 22.
Control board or wiring	1. Loose control board wiring	1. Repair any loose connections
	2. Damaged control board	2. Replace control board
Control/sensor	1. Potentiometer damaged	1. Replace potentiometer
	2. Pressure transducer damaged	2. Replace pressure transducer

Troubleshooting

PROBLEM	WHAT TO CHECK <i>If check is OK, go to next check</i>	WHAT TO DO <i>When check is not OK refer to this column</i>
Low or fluctuating output	1. For worn spray tip.	1. Follow Pressure Relief Procedure Warning , then replace tip. See your separate gun or tip manual.
	2. Verify pump does not continue to stroke when gun trigger is released.	2. Service pump. See page 23.
	3. Filter clogged.	3. Relieve pressure. Check and clean filter.
	4. Prime valve leaking.	4. Relieve pressure. Repair prime valve.
	5. Suction hose connections.	5. Tighten any loose connections.
	6. Electrical supply with volt meter. Meter must read: 210–255 Vac for 220–240 Vac models. 85–130 Vac for 100–120 Vac models. Low volt-ages reduce sprayer performance.	6. Reset building circuit breaker; replace building fuse. Repair electrical outlet or try another outlet.
	7. Extension cord size and length; must be at least 12 gauge wire and no longer than 300 ft. Longer cord lengths reduce sprayer performance.	7. Replace with a correct, grounded extension cord.
	8. Low stall pressure.	8. Do either or both: c. Turn pressure control knob fully clockwise. Make sure pressure control knob is properly installed to allow full clockwise position. d. Try a new transducer.
	9. Motor armature for shorts by using an armature tester (growler) or perform spin test. See page 9.	9. Replace motor. See page 22.
	10. Paint supply.	10. Refill and reprime pump.
	11. Intake strainer clogged.	11. Remove and clean, then reinstall.
	12. Suction tube or fittings loose.	12. Tighten; use thread sealant or sealing tape on threads if necessary.
	13. To see if intake valve ball and piston ball are seating properly. See page 23.	13. Remove intake valve and clean. Check balls and seats for nicks; replace if necessary, page 23. Strain paint before using to remove particles that could clog pump.
	14. Leaking around throat packing nut which may indicate worn or damaged packings. See page 23.	14. Replace packings, page 23. Also check piston valve seat for hardened paint or nicks and replace if necessary. Tighten packing nut/wet-cup.
	15. Pump rod damage	15. Repair pump, page 23.
Motor runs but pump does not stroke	1. Displacement pump pin (114) (damaged or missing), page 23.	1. Replace pump pin if missing. Be sure retainer spring (27) is fully in groove all around connecting rod, page 23.
	2. Connecting rod assembly (9) for damage, page 21.	2. Replace connecting rod assembly, page 21.
	3. Gears or drive housing, page 21.	3. Inspect drive housing assembly and gears for damage and replace if necessary, page 21.

Troubleshooting

TYPE OF PROBLEM	WHAT TO CHECK <i>If check is OK, go to next check</i>	WHAT TO DO <i>When check is not OK refer to this column</i>
<p>Building circuit breaker opens</p> <p>CAUTION Any short in any part of the motor power circuit will cause the control circuit to inhibit sprayer operation. Correctly diagnose and repair all shorts before checking and replacing control board.</p>	1. Current limit exceeded	1. Switch to another circuit with less load. If sprayer has a 15/20A or 10/12A switch, change to lower value.
	2. All electrical wiring for damaged insulation, and all terminals for loose fit or damage. Also wires between pressure control and motor. See page 22.	2. Repair or replace any damaged wiring or terminals. Securely reconnect all wires.
	3. For missing inspection plate gasket (see page 22), bent terminals or other metal to metal contact points which could cause a short.	3. Correct faulty conditions.
	4. Motor armature for shorts. Use an armature tester (growler) or perform spin test. See page 9. Inspect windings for burns.	4. Replace motor. See page 22.
	5. Motor control board (35) by performing motor control board diagnostics on page 16. If diagnostics indicate, substitute with a good board. CAUTION: Do not perform this check until motor armature is determined to be good. A bad motor armature can burn out a good board.	5. Replace with a new pressure control board (35). See page 16.
Display reads all 8's	Switches on back of display are set incorrectly.	Set the four switches psi, bar, MPa and liters/gallons to proper settings for your sprayer. Fig. 13, page 16.
AutoClean problem	Manual 309278	

Spin Test

Setup



Electric Shock Hazard; page 4.

To check armature, motor winding and brush electrical continuity:

1. Relieve pressure; page 4.

2. Remove drive housing; page 21.
3. Fig. 10. Remove four screws (60), pressure control cover (49), two screws (108), control panel (67). Fig. 3. Disconnect motor connector (F).
4. Fig. 4. Remove motor shroud (90) and inspection covers (A).

Armature Short Circuit Test

Quickly turn motor fan by hand. If no electrical shorts, motor coasts two or three revolutions before complete stop. If motor does not spin freely, armature is shorted. Replace motor; page 22.

Armature, Brushes, and Motor Wiring Open Circuit Test (Continuity)

1. Fig. 3. Connect red and black motor leads together with test lead. Turn motor fan by hand at about two revolutions per second.
2. If uneven or no resistance, check for: broken brush springs, brush leads, motor leads; loose brush terminal screws, motor lead terminals; worn brushes. Repair as needed; page 9.
3. If still uneven or no resistance, replace motor; page 22.

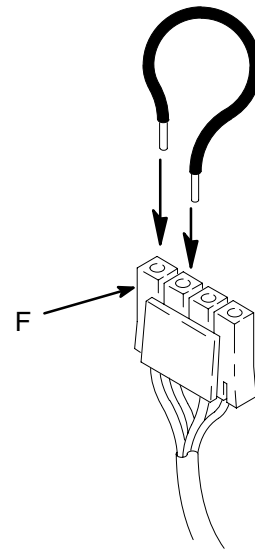

Fig. 3

ti0941

Motor Brush Replacement

695 Motor Brush Removal

Replace brushes worn to less than 1/2 in. Brushes wear differently on each side of motor, check both sides. Brush Repair Kit 243214 is available. Spring clip, 112766, may be purchased separately.

1. Read **General Repair Information;** page 4.

2. Relieve pressure; page 4.

3. Fig. 4. Remove motor shroud (90) and two inspection covers (A).

(Continued on page 10)

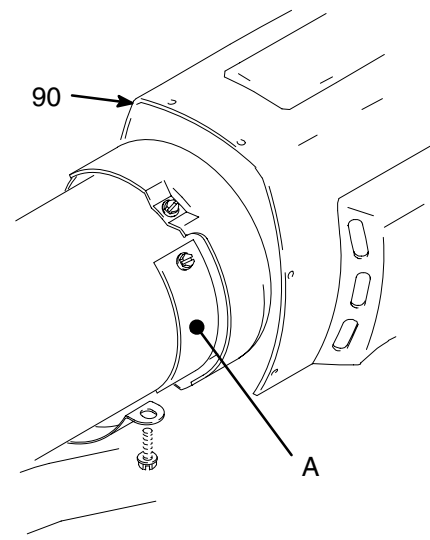

Fig. 4

7703B

Motor Brush Replacement

4. Fig. 5. Push in spring clip (A) to release hook (B) from brush holder (C). Pull out spring clip (A).
5. Fig. 5. Pull brush lead (D) out of terminal (E). Remove brush (F).

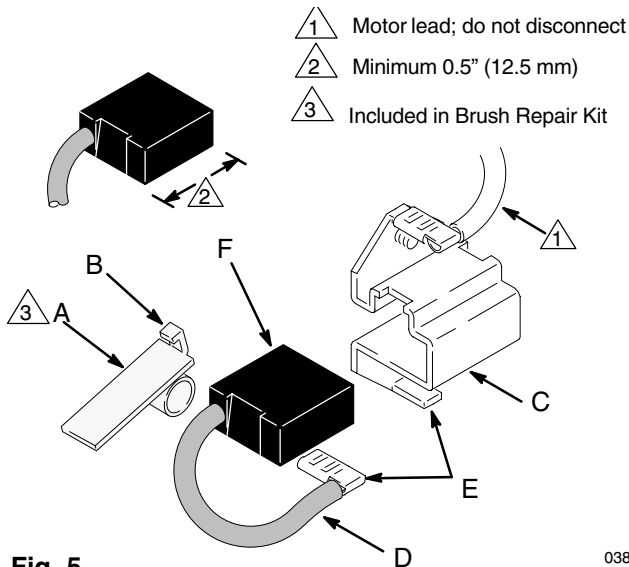

Fig. 5 03881

6. Inspect commutator for excessive pitting, burning or gouging. A black color on commutator is normal. Have commutator resurfaced by a motor repair shop if brushes wear too fast.

695 Motor Brush Installation

⚠ CAUTION

When installing brushes, follow all steps carefully to avoid damaging parts.

1. Fig. 6. Install new brush (F) with lead into brush holder (C).
2. Fig. 5. Slide brush lead (D) into terminal (E).
3. Fig. 6. Install spring clip (A). Push down to set hook (B) into brush holder (C).

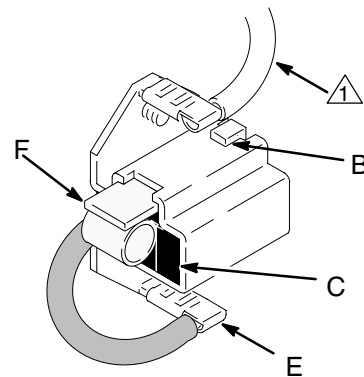

Fig. 6 03881

4. Repeat for other side.
5. Test brushes.
 - a. Remove pump (79); **Displacement Pump Replacement**, page 23.
 - b. With sprayer OFF, turn pressure control knob fully counterclockwise to minimum pressure. Plug in sprayer.
 - c. Turn sprayer ON. Slowly increase pressure until motor is at full speed.

⚠ CAUTION

Do not run sprayer dry for more than 30 seconds while checking brushes to avoid damaging displacement pump packings.

6. Install brush inspection covers and gaskets.
7. Break in brushes.
 - a. Operate sprayer 1 hour with no load.
 - b. Install pump (79); **Displacement Pump Replacement**, page 23.

Motor Brush Replacement

795/1095 Motor Brush Removal

NOTE: Replace brushes worn to less than 1/2 in. Brushes wear differently on each side of motor, check both sides. Brush Repair Kit 220853 is available. Spring clip, 110816, may be purchased separately.

1. Read **General Repair Information**; page 4.

2.  Relieve pressure; page 4.

3. Fig. 4. Remove motor shield (90). Remove inspection covers (B) and gaskets on each side of motor.

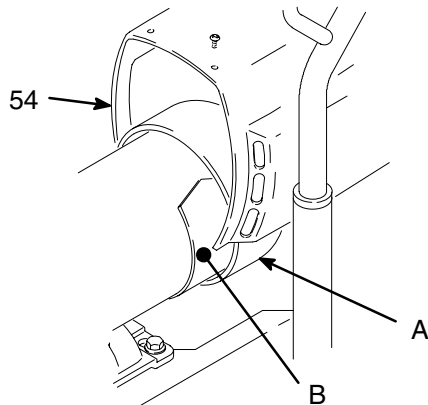

Fig. 7

7703B

4. Fig. 8. Push in 110816 spring clip (A) to release hooks (B) from brush holder (C). Pull out spring clip.
5. Fig. 8. Loosen terminal screw (D). Pull brush lead (E) away, leaving motor lead (F) in place. Remove brush (G) and spring (H).

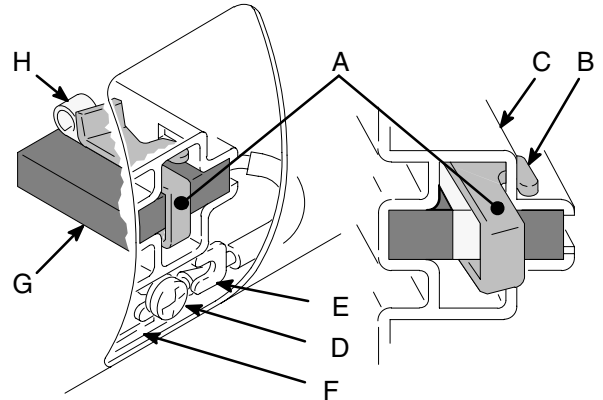

Fig. 8

01227

6. Inspect commutator for excessive pitting, burning or gouging. A black color on commutator is normal. Have commutator resurfaced by a qualified motor repair shop if brushes wear too fast.

(Continued on page 12)

Motor Brush Replacement

795/1095 Motor Brush Installation

⚠ CAUTION

When installing brushes, follow all steps carefully to avoid damaging parts.

7. Fig. 9. Install new brush (G) with lead (J) of brush holder (C).
8. Fig. 8. Slide brush lead (E) under washer of terminal screw (D) and tighten screw. Be sure motor lead (F) is connected at terminal screw.
9. Fig. 9. Place spring (H) on brush (G).
10. Fig. 9. Install spring clip (A). Push down to hook short slots (K) in brush holder (C).

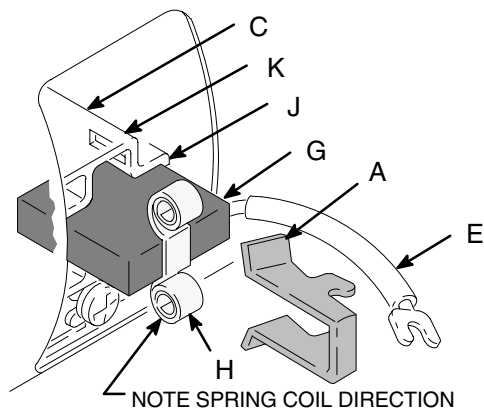

Fig. 9

01227

11. Repeat for other side.
12. Test brushes.
 - a. Remove pump connecting rod pin.
 - b. With sprayer OFF, turn pressure control knob fully counterclockwise to minimum pressure. Plug in sprayer.
 - c. Turn sprayer ON. Slowly increase pressure until motor is at full speed.

⚠ CAUTION

Do not run sprayer dry for more than 30 seconds while checking brushes to avoid damaging displacement pump packings.

13. Install brush inspection covers and gaskets.
14. Break in brushes.
 - a. Operate sprayer 1 hour with no load.
 - b. Install connecting rod pin.
15. Fig. 4. Install gaskets and inspection covers (B) on each side of motor. Install motor shield (90).

On/Off Switch Replacement

695/795 120 Vac (245000 – 245003, 245010, 245011, 245020 – 245023, 245028, 245050, 245051, 246308, 246309)

Removal

1.  Relieve pressure; page 4.
2. Fig. 10. Remove four screws (60) and pressure control cover (49). Disconnect display connector (B) (not available on all sprayers).
3. Remove two screws (108) and control panel (67).
4. Disconnect two wires (A) from ON/OFF switch (86).
5. Squeeze inside tabs on ON/OFF switch (86) and remove from control panel (67).

Installation

1. Push ON/OFF switch (86) into control panel (67) until inside tabs snap in place.
2. Connect two wires (A) to ON/OFF switch (86).
3. Install control panel (67) with two screws (108).
4. Connect display connector (B) (not available on all sprayers). Install pressure control cover (49) with four screws (60).

North America 695/795 120 VAC

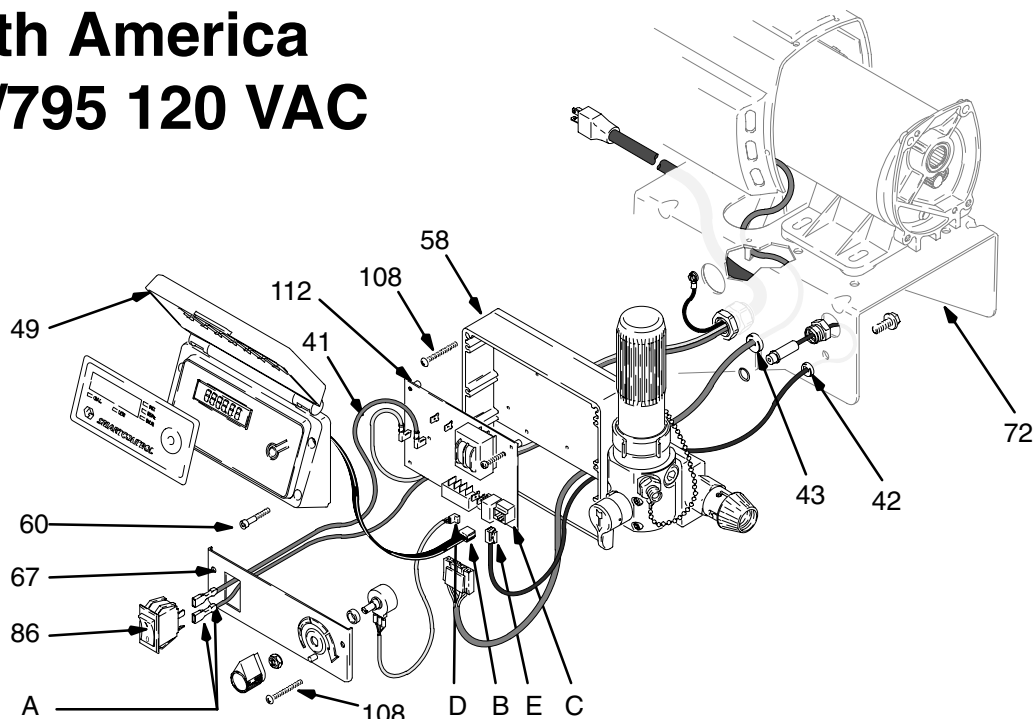

Wiring Diagram

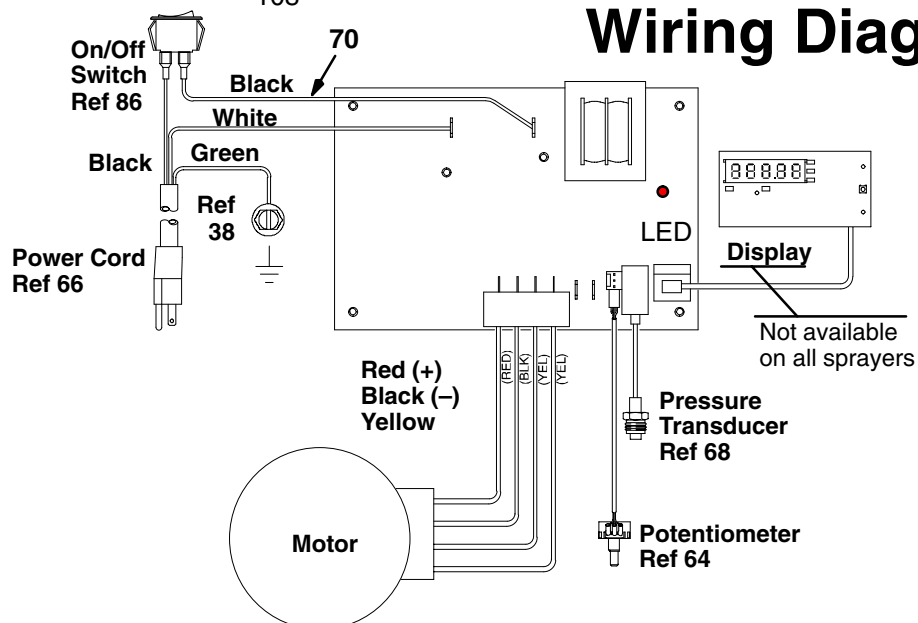



Fig. 10

ti0848A

On/Off and 15/20A Switch Replacement

1095 120 Vac (245030 – 245032, 245039)

Removal

1.  Relieve pressure; page 4.
2. Fig. 11. Remove four screws (60) and pressure control cover (49). Disconnect display connector (B).
3. Remove two screws (108) and control panel (67).
4. Disconnect two wires (A1) from ON/OFF switch (86).
5. Squeeze inside tabs on ON/OFF switch (86) and remove from control panel (67).
6. Disconnect two wires (A2) from 15/20A switch (86).
7. Squeeze inside tabs on 15/20A switch (60) and remove from control panel (67).

Installation

1. Push 15/20A switch (60) into control panel (67) until inside tabs snap in place.
2. Connect two wires (A2) to 15/20A switch (86).
3. Push ON/OFF switch (86) into control panel (67) until inside tabs snap in place.
4. Connect two wires (A1) to ON/OFF switch (86).
5. Install control panel (67) with two screws (108).
6. Install display connector (B). Install pressure control cover (49) with four screws (60).

North America 1095 120 VAC

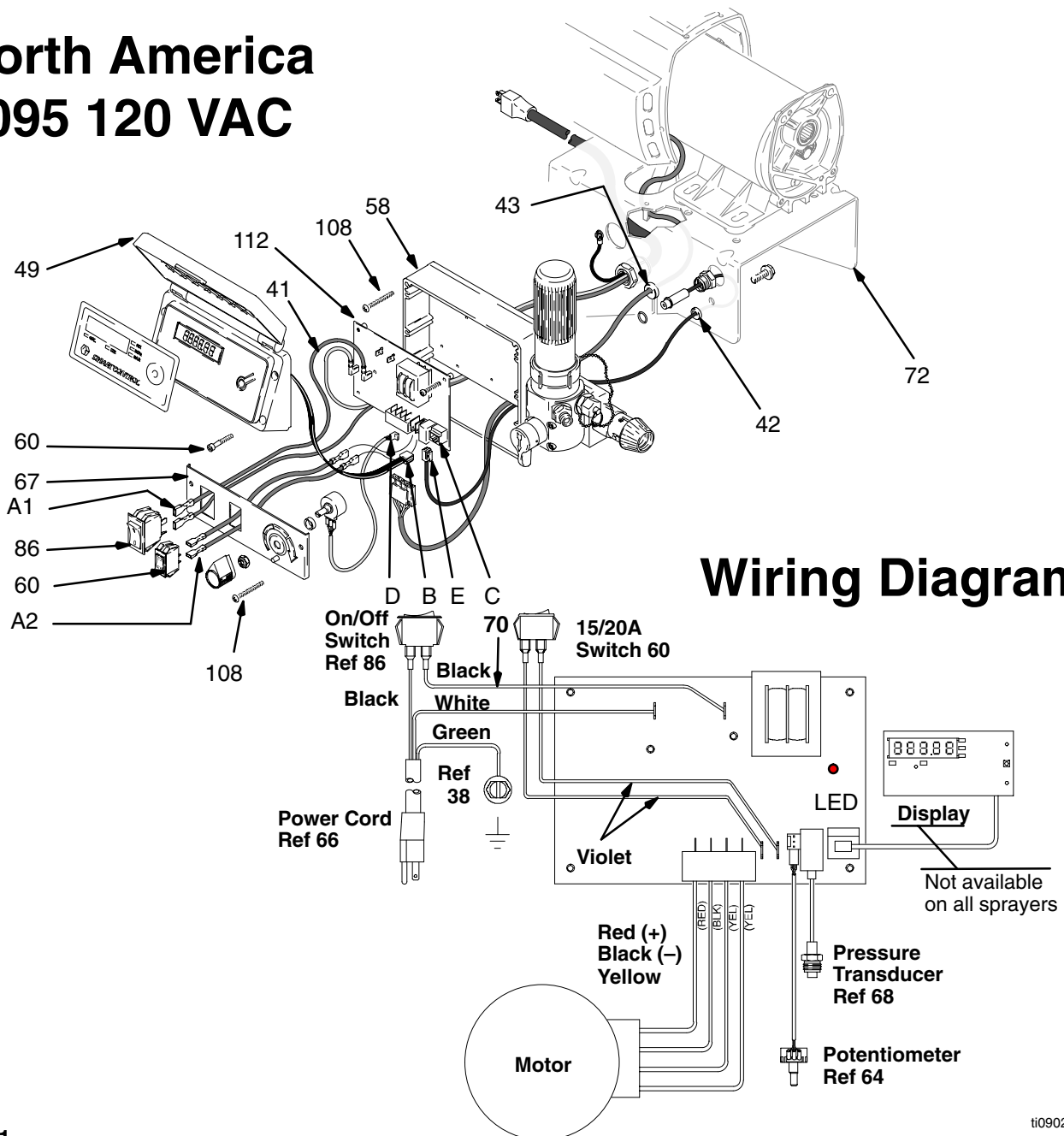



Fig. 11

On/Off Switch Replacement

695/795/1095 240 Vac (245004, 245005, 245009)

Removal

1.  Relieve pressure; page 4.
2. Fig. 12. Remove four screws (60) and pressure control cover (49). Disconnect display connector (B).
3. Remove two screws (108) and control panel (67).
4. Disconnect four wires (A) at ON/OFF switch (86).
5. Squeeze inside tabs on ON/OFF switch (86) and remove from control panel (67).

Installation

1. Push ON/OFF switch (86) into control panel (67) until inside tabs snap in place.
2. Connect four wires (A) to ON/OFF switch.
3. Install control panel (67) with two screws (108).
4. Install display connector (B). Install pressure control cover (49) with four screws (60).

695/795/1095 240 VAC

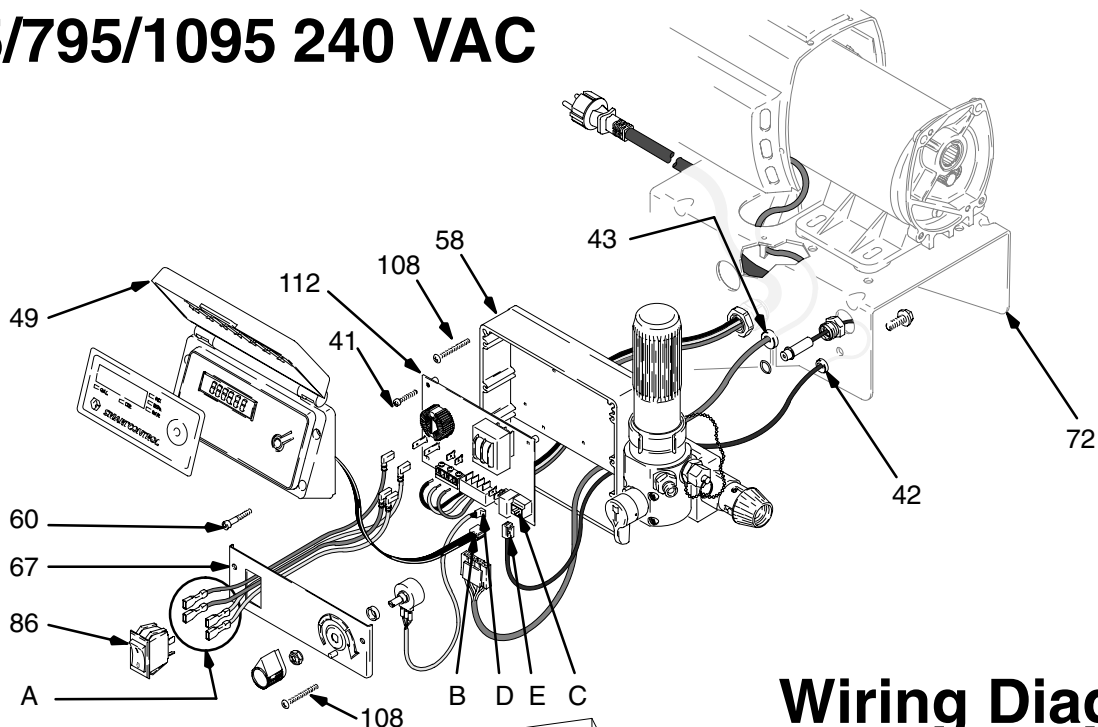

Wiring Diagram

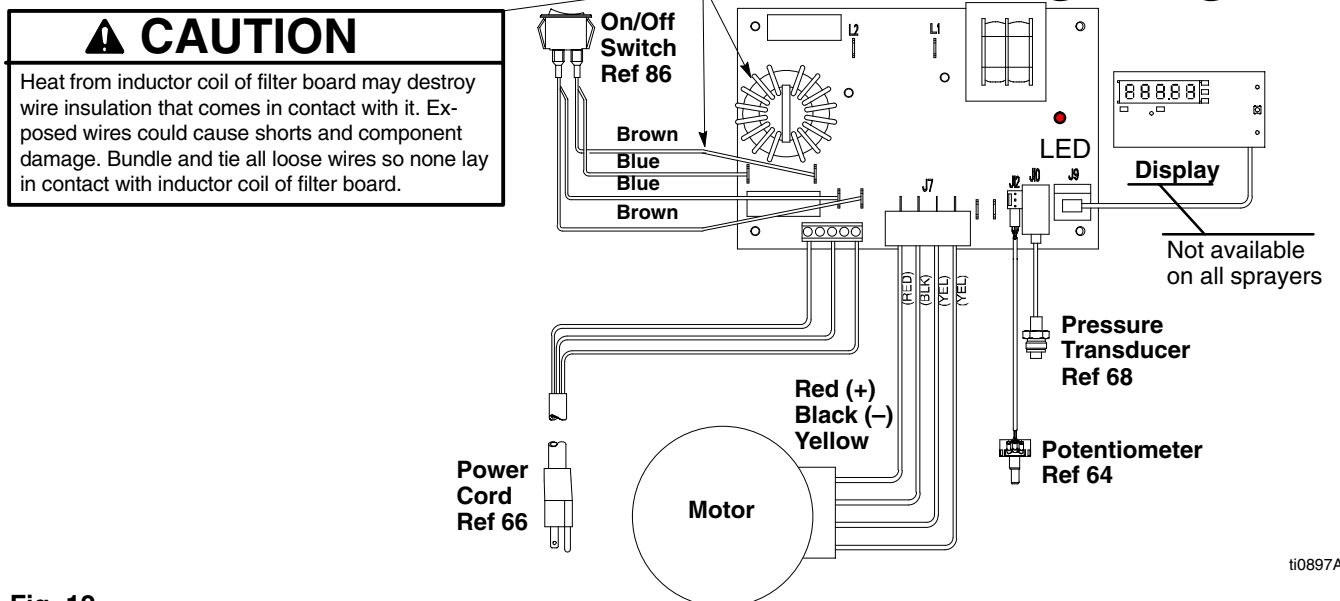

Fig. 12

ti0897A

Pressure Control Repair

Motor Control Board

Removal

Refer to Fig. 10, 11 or 12 depending on sprayer and voltage.

-  Relieve pressure; page 4.
- Remove four screws (60) and pressure control cover (49). Disconnect display connector (B).
- Remove two screws (108) and control panel (67).
- Disconnect at motor control board (112):
 - Motor connector: two yellow, black (+) and red (-).
 - Lead (D) from potentiometer.
 - Lead (E) from transducer.
 - Wires from power cord and switch
- Remove six screws (41) and motor control board (112).

Installation

- Clean pad on rear of motor control board. Apply small amount of thermal compound 073019 to pad.
- Fig. 10. Install motor control board (112) with six screws (41).
- Connect to motor control board (112):
 - Lead (E) to transducer.

- Lead (D) to potentiometer.
 - Motor connector: two yellow, black (+) and red (-).
 - Wires to power cord and switch
- Route loose wires so none lay in contact with inductor coil on filter board (not 120 Vac sprayers). See **Wiring Diagram CAUTION**, Fig. 11.
 - Install control panel (67) with two screws (108).
 - Install display connector (B). Install pressure control cover (49) with four screws (60).

Digital Display Settings (Not available on all sprayers)

The units on the digital display may be set to psi, bar, MPa and gallons or liters.

- Fig. 10. Remove four screws (60) and cover (49). Disconnect display cable (B).
- Set switches as desired, Fig. 13.

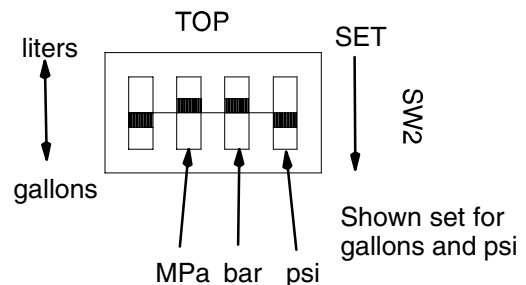



Fig. 13

Pressure Control Repair

Stored Data (Not available on all sprayers)

The SmartControl contains stored data to assist with troubleshooting and maintenance. To view this stored data on the digital display, proceed as follows:

1.   Relieve pressure; page 4.
 2. Plug in sprayer.
 3. Hold down display button and turn sprayer ON.
 4. Release display button about 1 second after turning on sprayer.
- Sprayer model number displays (U695, U795, etc.) for a few seconds and then data point 1 is displayed.
5. Push display button and next data point displays.
 6. Turn sprayer OFF and then ON to leave stored data mode.

Data Point	Definition
1	Number of hours power switch has been ON with power applied
2	Number of hours motor has been running
3	Number of hours sprayer has been above 500 psi with power applied
4	Not used
5	Last recorded Error Code E=XX. See Error Code messages on page 18.
6	Control board software revision number

Note: Gallon/liter counter resets to zero at 65,000 gallons (245 700 liters)

Pressure Control Repair

Digital Display Messages (Not available on all sprayers)



No display does not mean that sprayer is not pressurized. Relieve pressure before repair; page 4.

DISPLAY*	SPRAYER OPERATION	INDICATION	ACTION
No Display	Sprayer may be pressurized.	Loss of power or display not connected	Check power source. Relieve pressure before repair or disassembly. Verify display is connected.
3000 psi 210 bar 21 MPa	Sprayer is pressurized. Power is applied. (Pressure varies with tip size and pressure control setting.)	Normal operation	Spray
E:02	1. Sprayer stops. Power is applied. 2. Sprayer stops. Power is applied. 3. Sprayer continues to run	1. Exceeded pressure limit of 4500 psi. Sprayer is pressurized. 2. Sprayer is not pressurized 3. Pressure rise nears 4500 psi	1. Remove any filter clogs or flow obstructions. Lock gun trigger open if using AutoClean valve. 2. Replace transducer 3. Replace control board
E:03	Sprayer stops. Power is applied.	Pressure transducer faulty, bad connection or broken wire.	Check transducer connections and wire. Replace transducer or control board, if necessary.
E:04	Sprayer stops. Power is applied.	Line voltage too high	Check for voltage supply problem
E:05	Sprayer stops. Power is applied.	Too much motor current	Check for locked rotor, pump obstruction, damaged drive train, shorted wiring or motor. Repair or replace failed parts.
E:06	Sprayer stops. Power is applied.	No operation, motor over heated or unplugged	Allow sprayer to cool. Correct cause of overheating. Verify motor is plugged into motor control board
E:07	Sprayer stops. Power is applied.	Pressure greater than 2000 psi (138 bar, 14 MPa) while in Flush Timer Mode	Make sure spray gun is triggered and prime valve is open when using AutoClean
E:08	Sprayer stops. Power is applied.	Low line voltage	Check for voltage supply problem
8888	Power is applied.	Digital display switches are not set	Set switches on back of digital display to appropriate settings. Fig. 13, page 16.
- - - -	Sprayer may be pressurized.	Pressure less than 200 psi (14 bar, 1.4 MPa)	Increase pressure as needed

*Error codes also appear on control board as a blinking red LED. LED is an alternate to display.



Electric shock hazard; page 4.

1. Remove four screws (60) and cover (49).
2. Turn sprayer ON. Count LED blinks. Blink count is the same as error code (E=0X) in preceding **Digital Display Messages** table.
3. Follow instructions in table.

After a fault, do following steps to restart sprayer:

1. Correct fault condition
2. Turn sprayer OFF
3. Turn sprayer ON

Pressure Control Repair

Pressure Control Transducer

Removal

Refer to Fig. 10, 11 or 12 depending on sprayer voltage.

1.  Relieve pressure; page 4.
2. Remove four screws (60) and pressure control cover (49). Disconnect display connector (B).
3. Remove two screws (108) and control panel (67).
4. Remove upper two screws (108) and control housing (58).
5. Disconnect lead (E) from motor control board (112).
6. Unscrew nut holding transducer (68) in power bar plate (56).
7. Remove transducer and o-ring (26).
8. Remove grommet (42) holding transducer lead in cart frame (72).
9. Thread transducer lead plastic connector down through hole in cart frame.
10. Remove grommet from transducer lead.

Installation

1. Install grommet (42) on transducer lead.
2. Thread transducer lead plastic connector up through hole in cart frame (72) .
3. Install grommet holding transducer lead in cart frame.
4. Install o-ring (26) and transducer (68).
5. Screw nut holding transducer in power bar plate (56). Torque to 30–35 ft-lb.
6. Connect lead (E) to motor control board (112).
7. Install control housing (58) with upper two screws (108).
8. Install control panel (67) with two screws (108).
9. Install display connector (B). Install pressure control cover (49) with four screws (60).

Pressure Adjust Potentiometer

Removal

Refer to Fig. 10, 11 or 12 depending on sprayer voltage.

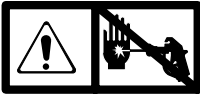
1.  Relieve pressure; page 4.
2. Remove four screws (60) and pressure control cover (49). Disconnect display connector (B).
3. Remove two screws (108) and control panel (67).
4. Disconnect lead (D) from motor control board (112).
5. Remove potentiometer knob (36), sealing shaft nut (32), shaft spacer (96) and pressure adjust potentiometer (64).

Installation



1. Install pressure adjust potentiometer (64), shaft spacer (96), sealing shaft nut (32) and potentiometer knob (36).
 - a. Turn potentiometer fully clockwise.
 - b. Install knob at full clockwise position.
2. Connect lead (D) to motor control board (112).
3. Install control panel (67) with two screws (108).
4. Install display connector (B). Install pressure control cover (49) with four screws (60).

Drive Housing Replacement

CAUTION

Do not drop gear cluster (7) when removing drive housing (10). Gear cluster may stay engaged in motor front end bell or drive housing.

695 Removal

-   Relieve pressure; page 4.
- Remove pump (79); **Displacement Pump Replacement**, page 23.
- Fig. 15. Remove four screws (39) and remove shroud (90).
- Remove four screws (104) and washers (17).
- Remove four screws (40) and front cover (100).
- Remove two nuts (33), pail hanger (54) and spring clip (95).

- Remove two screws (105) and washers (17).
- Pull drive housing (78) off of motor (75).
- Slide connecting rod (76) out of drive housing.

695 Installation

- Slide connecting rod (76) into drive housing.
- Push drive housing (78) onto motor (75).
- Install washers (17) and two screws (105).
- Install spring clip (95), pail hanger (54) and two nuts (33).
- Install front cover (100) and four screws (40).
- Install washers (17) and four screws (104).
- Fig. 15. Install shroud (90) with four screws (39).
- Install pump (79); **Displacement Pump Replacement**, page 23.

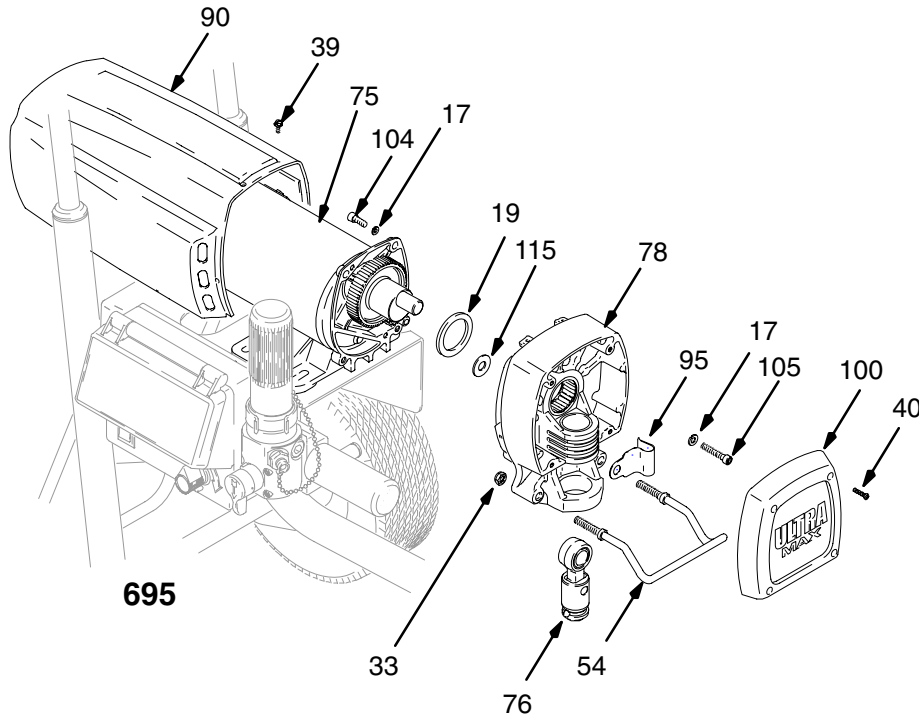

Fig. 14



ti0767A

Drive Housing Replacement

CAUTION

Do not drop gear cluster (7) when removing drive housing (10). Gear cluster may stay engaged in motor front end bell or drive housing.

795/1095 Removal

-   Relieve pressure; page 4.
- Remove pump (79); **Displacement Pump Replacement**, page 23.
- Fig. 15. Remove four screws (123) and remove shroud (90).
- Remove four screws (10) and washers (15).
- Remove four screws (101) and front cover (104).
- Remove two nuts (33), pail hanger (54) and spring clip (129).
- Remove four screws (19) and washers (17) and bearing housing (126) from drive housing (78).

- Remove two screws (20) and washers (15) and pull drive housing (78) off of motor (75).
- Slide connecting rod (76) out of bearing housing.

795/1095 Installation

- Slide connecting rod (76) into bearing housing.
- Push drive housing (78) onto motor (75) and install with two washers (15) and screws (20).
- Install bearing housing (126) on drive housing (78) with four screws (19) and washers (17).
- Install spring clip (129), pail hanger (54) and two nuts (33).
- Install front cover (124) and four screws (101).
- Install washers (10) and four screws (15).
- Fig. 15. Install shroud (90) with four screws (123).
- Install pump (79); **Displacement Pump Replacement**, page 23.

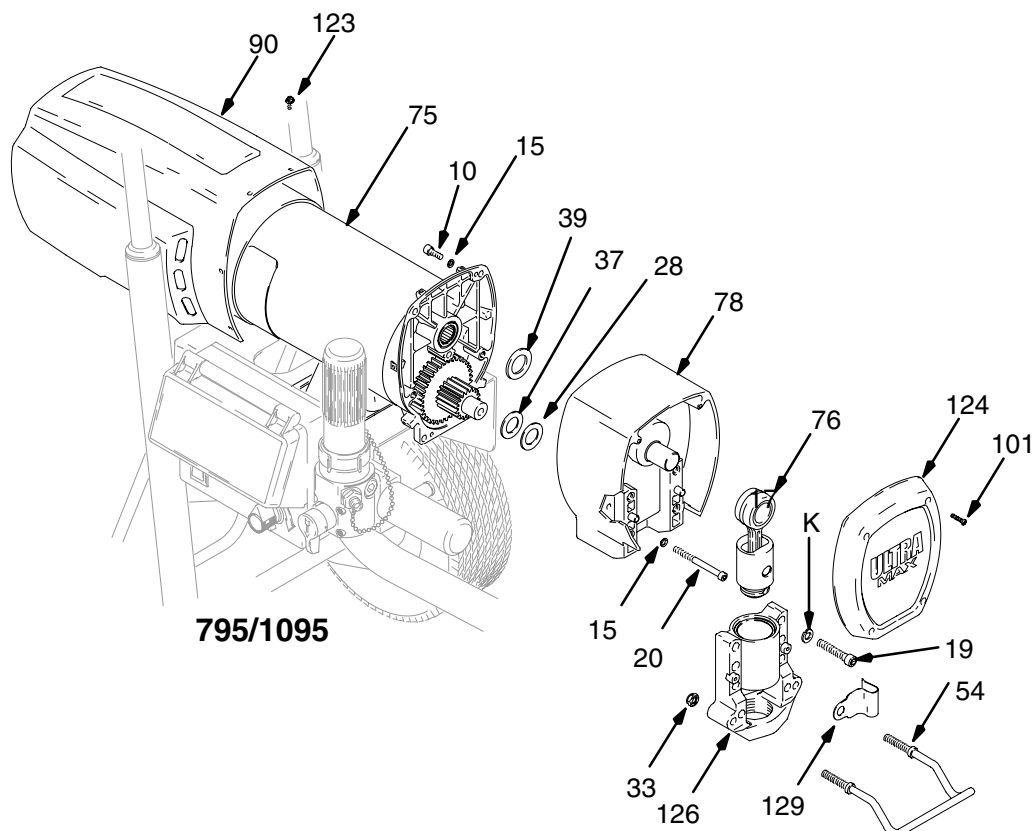

Fig. 15

Motor Replacement

Removal

1.  Relieve pressure; page 4.
2. Remove pump (79); **Displacement Pump Replacement**, page 23.

CAUTION

Do not drop gear cluster (A) when removing drive housing (78). Gear cluster may stay engaged in motor front end bell or drive housing.

3. Remove drive housing (78); **Drive Housing Replacement**, page 21.
4. Remove four screws (60) and cover (49).
5. Disconnect lead (B) from board (112).
6. Remove two screws (108) and panel (67).
7. Remove two top screws (108) and housing (58).
8. Disconnect all leads from board (112).
9. Remove strain relief (43, page 13, 14, 15).

10. Thread motor lead (J) out through slot in frame.
11. Remove four screws (31), nuts (127) and motor (75) from frame (72).

Installation

1. Install new motor (75) on cart frame (72) with four screws (31) and nuts (127).
2. Thread motor lead (J) in through slot in frame.
3. Install strain relief (43, page 12, 13, 14).
4. Connect all leads to board (112).
5. Install control housing (58) with two screws (108).
6. Install panel (67) with two screws (108).
7. Connect lead (B) to board (112).
8. Install cover (49) with four screws (60).
9. Install drive housing (78); **Drive Housing Replacement**, page 21.
10. Install pump (79); **Displacement Pump Replacement**, page 23.

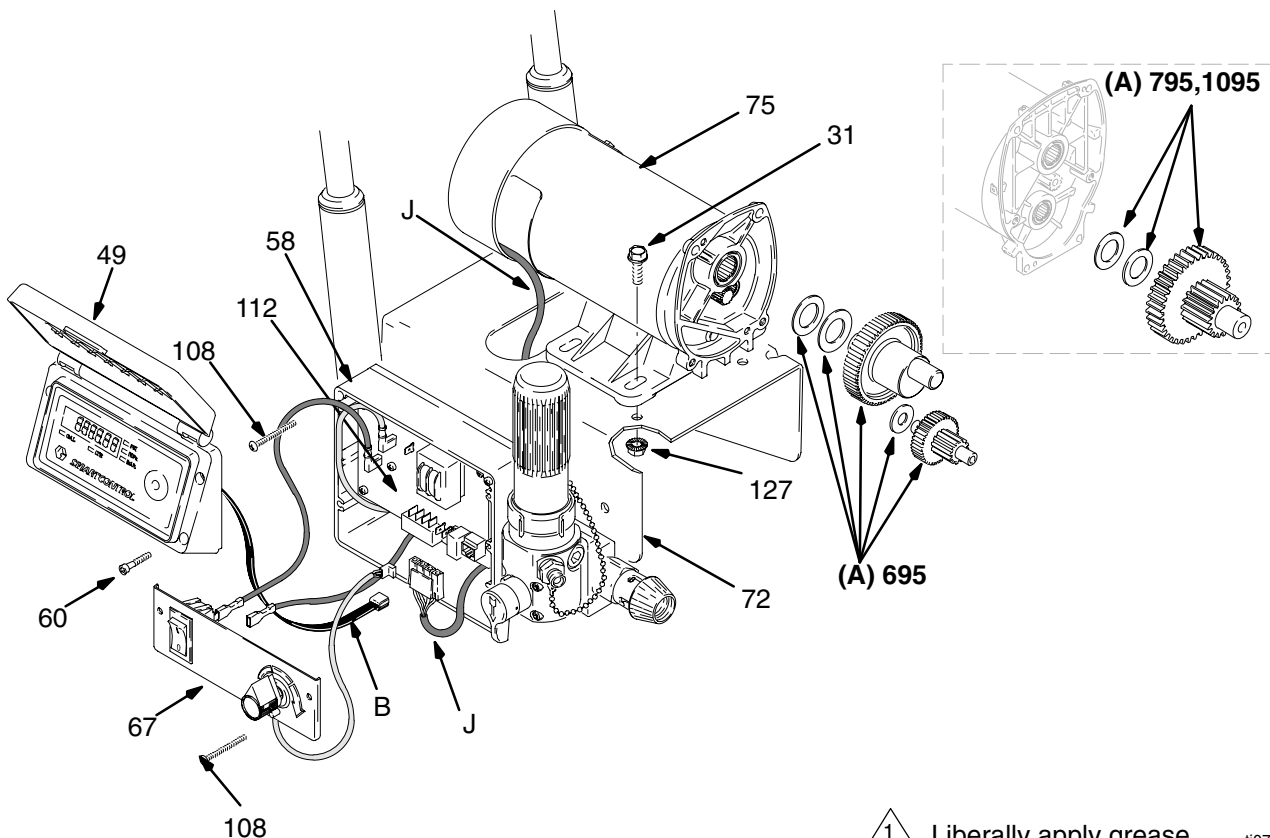



Fig. 16

 Liberally apply grease

ti0767A

Displacement Pump Replacement

See manual 309250 or 309277 for pump repair instructions.

See parts manuals for sprayer part number references.

Removing pump

1. Flush pump. Relieve pressure. Fig. 17. Cycle pump with piston rod (201) in its lowest position.
2. Fig. 17. Remove suction tube and hose.

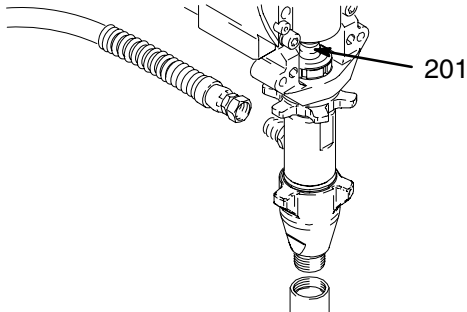

Fig. 17 ti0915

3. Fig. 18. Use screwdriver: push retaining spring up and push out pin.

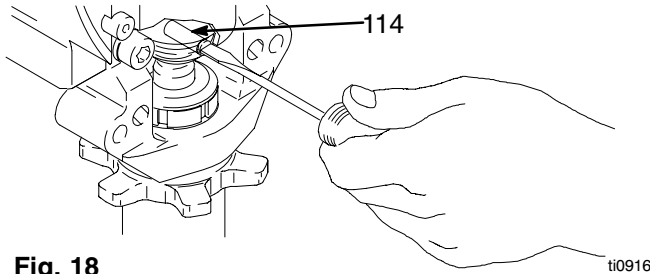

Fig. 18 ti0916

4. Fig. 19. Loosen locknut by hitting firmly with a plastic hammer. Unscrew pump.

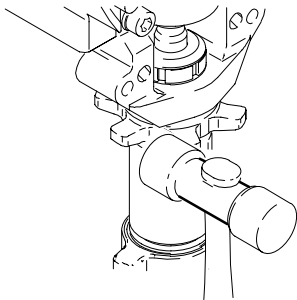

Fig. 19 ti0917

Installing pump

⚠ WARNING

If pin works loose, parts could break off due to force of pumping action. Parts could project through the air and result in serious injury or property damage. Make sure pin is properly installed.

⚠ CAUTION

If the pump jam nut loosens during operation, the threads of the bearing housing and drive train will be damaged. Make sure jam nut is tightened to 75 +/-5 ft-lb (102 N-m).

1. Fig. 20. Pull piston rod out 1.5 in. Screw in pump until holes in bearing cross link and piston rod align.

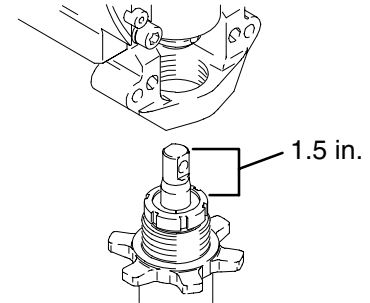

Fig. 20 ti0918

2. Fig. 18. Push pin (21) into hole. And push retaining spring into groove all the way around connecting rod.

Fig. 21. Screw jam nut down onto pump until stops. Screw pump up into bearing housing until it is stopped by jam nut. Back off pump and jam nut to align pump outlet to back. Tighten jam nut by hand, then tap 1/8 to 1/4 turn with a plastic hammer to approximately 75 +/-5 ft-lb (102 N-m).

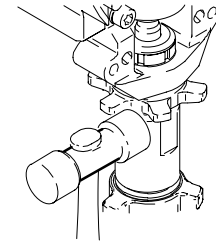

Fig. 21 ti0917

- Fig. 22. Fill packing nut with Graco TSL, through one of the slits, until fluid flows onto the top of seal.

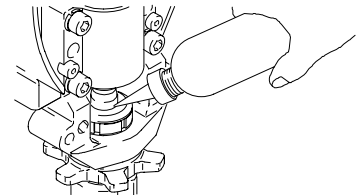

Fig. 22 7677B

Technical Data

Model	100–120V, Ø, A, Hz	220–240V, Ø, A, Hz	Generator Minimum W	Motor HP (W)	Cycles per gallon (liter)	Maximum Delivery gpm (lpm)	Maximum Tip size		Fluid Outlet npsm
							1 gun	2 guns	
695	1, 15, 50/60	1, 10, 50/60	3000	0.9 (373)	566 (150)	0.6 (2.3)	0.026	N/A	1/4 in.
795	1, 15, 50/60	1, 10, 50/60	4000	1.0 (466)	244 (64.6)	0.8 (3.0)	0.028	0.019	1/4 in.
1095	1, 15/20, 50/60	1, 10, 50/60	4000	1.2 (560)	200 (53)	1.1 (3.8)	0.032	0.021	1/4 in.

Basic Sprayer Wetted Parts:
zinc-plated carbon steel, polyurethane, polyethylene,
stainless steel, PTFE, Delrin®, chrome plating,
leather, V-Max™ UHMWPE, aluminum, stainless
steel, tungsten carbide

NOTE: Delrin® is a registered trademark of the
DuPont Co.

Dimensions

Model	Style	Weight lb (kg)	Height in. (cm)	Width in. (cm)	Length in. (cm)
695	Hi-Boy	87 (39)	30 (76)	22.5 (57)	25.5 (65)
	Lo-Boy	78 (35)	22 (56)	19.5 (49.5)	27 (69)
795	Hi-Boy	107 (48.5)	30 (76)	20.5 (52.1)	28 (71)
	Lo-Boy	101 (46)	22 (56)	22.5 (57)	27 (69)
1095	Hi-Boy	120 (54)	30 (76)	22.5 (57)	29 (74)

Graco Phone Number

TO PLACE AN ORDER OR FOR SERVICE, contact your Graco distributor,
or call **1-800-690-2894** to identify the nearest distributor.

*All written and visual data contained in this document reflects the latest product information available at the time of publication.
Graco reserves the right to make changes at any time without notice.*

Sales Offices: Minneapolis, Detroit
International Offices: Belgium, Korea, Hong Kong, Japan

www.graco.com

PRINTED IN USA 309251 01/2001, Revised 3/2003