

**REPAIR -
RÉPARATION -
REPARAÇÃO -
REPARACIÓN**



309060

Rev. F
Rév. F

190ES™ Displacement Pump

Bas de pompe 190ES™

Pistão de bombagem 190ES™

Base de bomba 190ES™

3000 psi (207 bar, 20.7 MPa) Maximum Working Pressure

Pression de service maximum 3000 psi (207 bar, 20.7 MPa)

Pressão máxima de trabalho de 3000 psi (207 bar, 20.7 MPa)

Presión máxima de funcionamiento de 3000 psi (207 bar, 20.7 MPa)

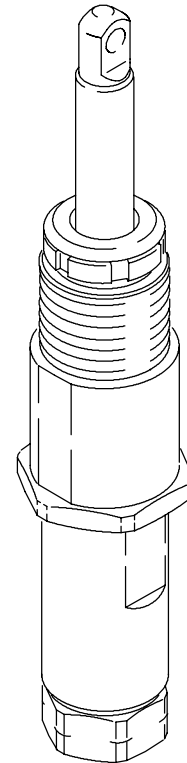

ti5991a

243187

The following are general Warnings related to the safe setup, use, maintenance and repair of this equipment. Additional, more specific warnings may be found throughout the text of this manual where applicable.

WARNING



FIRE AND EXPLOSION HAZARD

Flammable fumes, such as solvent and paint fumes, in work area can ignite or explode. To help prevent fire and explosion:

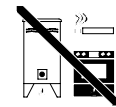

- Use equipment only in well ventilated area.
- Eliminate all ignition sources; such as pilot lights, cigarettes, portable electric lamps, and plastic drop clothes (potential static arc).
- Keep work area free of debris, including solvent, rags and gasoline.
- Do not plug or unplug power cords or turn lights on or off when flammable fumes are present.
- Ground equipment and conductive objects in work area. Read Grounding instructions.
- If there is static sparking or you feel a shock, stop operating immediately. Do not use equipment until you identify and correct the problem.



INJECTION HAZARD

High pressure fluid from gun, hose leaks, or ruptured components will pierce skin. This may look like just a cut, but it is a serious injury that can result in amputation. **Get immediate medical attention.**

- Do not point gun at anyone or any part of the body.
- Do not put your hand over the spray tip.
- Do not stop or deflect leaks with your hand, body, glove, or rag.
- Do not spray without tip guard and trigger guard installed.
- Engage trigger lock when not spraying.
- Follow Pressure Relief Procedure in this manual, when you stop spraying and before cleaning, checking or servicing equipment.



INSTRUCTIONS

EQUIPMENT MISUSE HAZARD

Misuse can cause death or serious injury.

- Do not exceed the maximum working pressure or temperature rating of the lowest rated system component. Read **Technical Data** in all equipment manuals.
- Use fluids and solvents that are compatible with equipment wetted parts. Read **Technical Data** in all equipment manuals. Read fluid and solvent manufacturer's warnings.
- Check equipment daily. Repair or replace worn or damaged parts immediately.
- Do not alter or modify equipment.
- Use equipment only for its intended purpose. Call your Graco distributor for information.
- Route hoses and cables away from traffic areas, sharp edges, moving parts and hot surfaces.
- Do not use hoses to pull equipment.
- Keep children and animals away from work area.
- Comply with all applicable safety regulations.







PRESSURIZED ALUMINUM PARTS HAZARD

Do not use 1,1,1-trichloroethane, methylene chloride, other halogenated hydrocarbon solvents or fluids containing such solvents in this equipment. Such use could result in a serious chemical reaction, with the possibility of explosion, which could cause death, serious injury and/or substantial property damage.

Ce qui suit sont des avertissements généraux liés à l'installation, à l'utilisation, à l'entretien et à la réparation sûrs de cet équipement. Des avertissements additionnels et plus spécifiques peuvent être trouvés dans tout le texte de ce manuel là où applicables.

! MISE EN GARDE

	<p>DANGER D'INCENDIE ET D'EXPLOSION</p> <p>Les vapeurs inflammables, vapeurs de solvant et de peinture par exemple, sur le lieu de travail peuvent s'enflammer ou exploser. Pour prévenir un incendie ou une explosion:</p> <ul style="list-style-type: none"> • N'utiliser l'équipement que dans des locaux bien ventilés. • Supprimer toutes les source de feu, telles que les veilleuses, cigarettes, lampes électriques portatives et bâches plastique (risque de décharge d'électricité statique). • Veiller à débarrasser la zone de travail de tout résidu, comme les solvants, les chiffons et l'essence. • Ne pas brancher ni débrancher de cordons d'alimentation électrique ni allumer ou éteindre la lumière en présence de vapeurs inflammables. • Raccorder le matériel et les objets conducteurs se trouvant dans la zone de travail à la terre. • Si l'on remarque la moindre étincelle d'électricité statique ou si l'on ressent une décharge électrique, arrêter le travail immédia.
	<p>DANGER D'INJECTION</p> <p>Le produit s'échappant à haute pression du pistolet, d'une fuite sur le flexible ou d'un composant défectueux risque de transpercer la peau. La blessure peut avoir l'aspect d'une simple coupure, mais il s'agit en fait d'une blessure sérieuse pouvant entraîner une amputation. Consulter immédiatement un médecin.</p> <ul style="list-style-type: none"> • Ne pas diriger le pistolet sur quelqu'un ou une partie quelconque du corps. • Ne pas mettre la main devant la buse de projection. • Ne jamais colmater ou dévier les fuites avec la main, le corps, un gant ou un chiffon. • Ne pas pulvériser sans garde-buse ni sous-garde. • Verrouiller la gâchette à chaque arrêt de la pulvérisation. • Observer la Procédure de décompression de ce manuel à chaque arrêt de la pulvérisation et avant tout nettoyage, contrôle ou entretien du matériel.
 <p>INSTRUCTIONS</p>	<p>RISQUE D'ABUS D'ÉQUIPEMENT</p> <p>L'abus peut causer la mort ou des dommages sérieux.</p> <ul style="list-style-type: none"> • N'excédez pas l'estimation maximum de pression ou de température d'utilisation du plus bas composant évalué de système. Lisez les données techniques en tous les manuels d'équipement. • Employez les fluides et les dissolvants qui sont compatibles avec les pièces mouillées par équipement. Lisez les données techniques en tous les manuels d'équipement. Lisez les avertissements liquides et dissolvants de manufacturer's. • Vérifiez le journal d'équipement. Réparez ou remplacez les pièces usées ou endommagées immédiatement. • Ne changez pas ou ne modifiez pas l'équipement. • Utilisez l'équipement seulement pour son but prévu. Appelez votre distributeur de Graco pour information. • Conduisez les tuyaux et les câbles loin des chaussées, des bords pointus, des pièces mobiles et des surfaces chaudes. • N'utilisez pas les tuyaux pour tirer l'équipement. • Maintenez les enfants et les animaux partis de la zone de travail. • Conformez-vous à tous les règlements applicables de sûreté.
	<p>RISQUES LIES AUX PIÈCES EN ALUMINIUM SOUS PRESSION.</p> <p>N'utiliser ni 1,1,1-trichloréthane, ni chlorure de méthylène, ni solvants à base d'hydrocarbures halogénés, ni produits renfermant de tels solvants dans un appareil sous pression en aluminium. L'utilisation de ces produit peut déclencher une violente réaction chimique et une casse du matériel et provoquer ainsi de graves dommages corporels et matériels pouvant entraîner la mort.</p>

Los siguientes son advertencias generales relacionadas con la disposición, el uso, el mantenimiento y la reparación seguros de este equipo. Las advertencias adicionales, más específicas se pueden encontrar a través del texto de este manual donde aplicables.

ADVERTENCIA



PELIGRO DE INCENDIOS Y EXPLOSIONES

Vapores inflamables, como los vapores de disolvente o de pintura en la zona de trabajo pueden incendiarse o explotar. Para evitar un incendio o explosión:

- Utilice el equipo únicamente en áreas bien ventiladas.
- Elimine toda fuente de ignición, tales como las luces piloto, los cigarrillos, las linternas eléctricas y las cubiertas de plástico (arcos estáticos potenciales).
- Mantenga limpia la zona de trabajo, sin disolventes, trapos o gasolina.
- No enchufe ni desenchufe cables de alimentación ni apague ni encienda las luces en el área de pulverización.
- Conecte a tierra el equipo y los objetos conductores eléctricamente de la zona de trabajo.
- Si se aprecia la formación de electricidad estática durante el uso de este equipo, deje de trabajar inmediatamente. No utilice el sistema hasta haber identificado y corregido el problema.

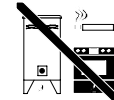

PELIGRO DE INYECCIÓN

El fluido a alta presión procedente de la pistola, fugas de la manguera o componentes rotos penetrarán en la piel. La inyección del líquido puede tener la apariencia de un simple corte, pero se trata de una herida grave que puede conducir a la amputación. Consiga atención médica inmediatamente.

- No coloque la mano o los dedos sobre la boquilla de pulverización, ni apunte la pistola hacia nadie ni ninguna parte del cuerpo.
- No coloque la mano sobre la boquilla de pulverización.
- No intente bloquear ni desviar posibles fugas con la mano, el cuerpo, los guantes o con un trapo.
- Nunca pulverice sin la protección de la boquilla y el seguro del gatillo.
- Enganche el seguro del gatillo cuando no esté pulverizando.
- Siga el Procedimiento de descompresión de este manual, cuando deje de pulverizar y antes de limpiar, revisar o reparar el equipo.



INSTRUCTIONS

PELIGRO DEL USO ERRÓNEO DEL EQUIPO

El uso erróneo puede causar muerte o lesión seria.

- No exceda el grado máximo de la presión o de la temperatura de funcionamiento del componente clasificado más bajo del sistema. Lea los datos técnicos en todos los manuales del equipo.
- Utilice los líquidos y los solventes que son compatibles con las piezas mojadas equipo. Lea los datos técnicos en todos los manuales del equipo. Lea las advertencias flúidas y solventes de manufacturer's.
- Compruebe el diario del equipo. Repare o sustituya las piezas gastadas o dañadas inmediatamente.
- No altere ni modifique el equipo.
- Utilice el equipo solamente para su propósito previsto. Llame su distribuidor de Graco para la información.
- Encamine las mangueras y los cables lejos de áreas de tráfico, de bordes agudos, de piezas móviles y de superficies calientes.
- No utilice las mangueras para tirar del equipo.
- Mantenga los niños y los animales ausentes de área de trabajo.
- Confórmese con todas las regulaciones aplicables de seguridad.





PELIGRO DE PIEZAS DE ALUMINIO PRESURIZADAS

No utilice 1,1,1 tricloroetano, cloruro de metileno y otros disolventes de hidrocarburos halogenados o productos que contengan dichos disolventes con equipos de aluminio presurizados. Esas sustancias podrían provocar peligrosas reacciones químicas y ruptura del equipo, y causar la muerte, lesiones graves y daños materiales.

Os seguintes são avisos gerais relacionados à instalação, ao uso, à manutenção e ao reparo seguros deste equipamento. Os avisos adicionais, mais específicos podem ser encontrados durante todo o texto deste manual onde aplicáveis.

! ADVERTÊNCIA

	<p>PERIGO DE INCÊNDIO E EXPLOSÃO</p> <p>Os vapores inflamáveis na área de trabalho, tais como os provenientes de solventes e tintas, podem inflamar-se ou explodir. Para ajudar a evitar incêndios e explosões:</p> <ul style="list-style-type: none"> ● Utilize o equipamento apenas em áreas bem ventiladas. ● Elimine todas as fontes de ignição, como, por exemplo, luzes piloto, cigarros, luzes eléctricas portáteis e plásticos de protecção (potencial arco estático). ● Mantenha a área de trabalho sem detritos, incluindo solvente, panos e gasolina. ● Não ligue nem desligue cabos de alimentação ou luzes na presença de vapores inflamáveis. ● Ligue o equipamento e os objectos condutores presentes na área de trabalho à terra. ● Se ocorrerem faíscas de estática ou se sentir um choque eléctrico, interrompa a utilização imediatamente. Não utilize o equipamento até identificar e eliminar o problema.
	<p>PERIGO DE INJEÇÃO</p> <p>O produto a alta pressão proveniente da pistola, fugas nos tubos flexíveis ou componentes danificados poderá provocar lesões na pele. As lesões podem ter o aspecto de um simples corte, porém, constituem ferimentos graves capazes de conduzir à amputação. Obtenha aconselhamento médico imediato.</p> <ul style="list-style-type: none"> ● Não aponte a pistola a ninguém nem a nenhuma parte do corpo. ● Não coloque as mãos sobre o bico. ● Não tente interromper ou desviar fugas com a mão, o corpo, uma luva ou um pano. ● Não comece a pintar sem que o protector do bico e o dispositivo de segurança do gatilho estejam instalados. ● Engate o dispositivo de segurança do gatilho quando não estiver a pintar. ● Siga o Procedimento de Descompressão neste manual, quando parar de pintar e antes de dar início aos procedimentos de limpeza, verificação ou manutenção. INJECTION HAZARD
 <p>INSTRUCTIONS</p>	<p>PERIGO DO EMPREGO ERRADO DO EQUIPAMENTO</p> <p>O emprego errado pode causar a morte ou ferimento sério.</p> <ul style="list-style-type: none"> ● Não exceda a avaliação máxima da pressão ou da temperatura de funcionamento do componente rated o mais baixo do sistema. Leia dados técnicos em todos os manuais do equipamento. ● Use os líquidos e os solventes que são compatíveis com as peças molhadas equipamento. Leia dados técnicos em todos os manuais do equipamento. Leia os avisos fluidos e solventes de manufacturer's. ● Verifique o diário do equipamento. Repare ou substitua as peças gastas ou danificadas imediatamente. ● Não altere nem não modifique o equipamento. ● Use o equipamento somente para sua finalidade pretendida. Chame seu distribuidor de Graco para a informação. ● Distribua mangueiras e cabos away das áreas de tráfego, das bordas afiadas, das peças moventes e das superfícies quentes. ● Não use mangueiras puxar o equipamento. ● Mantenha as crianças e os animais ausentes da área de trabalho. ● Comply com todos os regulamentos aplicáveis de segurança.
	<p>PERIGO DE PEÇAS DE ALUMÍNIO PRESSURIZADO</p> <p>Não utilize 1,1,1-tricloroetano, cloreto de metileno, outros solventes de hidrocarboneto halogenado ou produtos que contenham os solventes referidos em equipamento de alumínio pressurizado. A utilização dos produtos referidos pode provocar reacções químicas violentas e avaria do equipamento e resultar em morte, lesões graves e danos em bens.</p>

PRESSURE RELIEF / DÉCOMPRESSION / DESCOMPRESSÃO / DESCOMPRESIÓN



Follow 1-5 when you stop spraying.
Effectuer les opérations 1-5 lors d'un arrêt de la pulvérisation.

Siga os passos de 1-5 quando parar de pintar.

Cuando deje de pulverizar, siga los pasos 1-5.

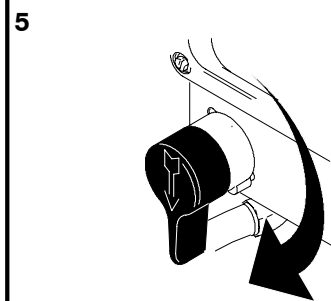
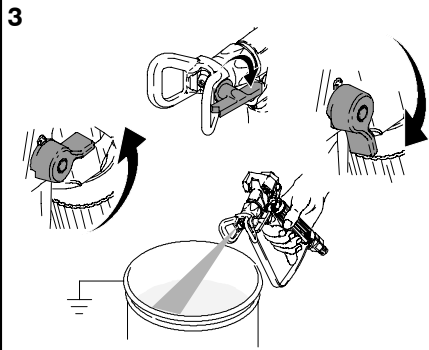
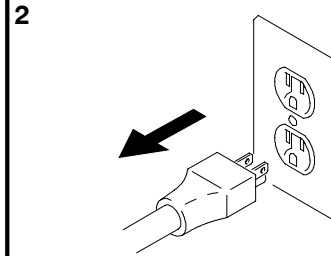
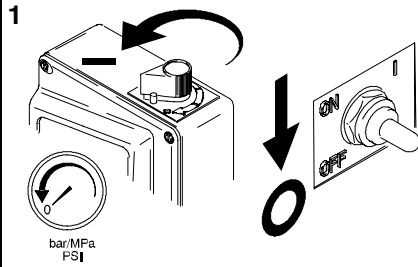

DISASSEMBLE / DÉMONTAGE / DESMONTAGEM / DESARMADO

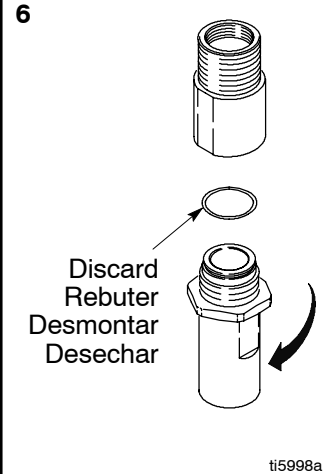
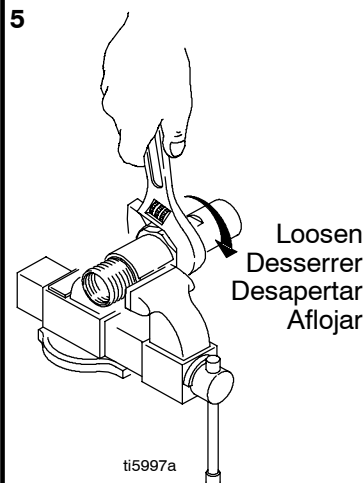
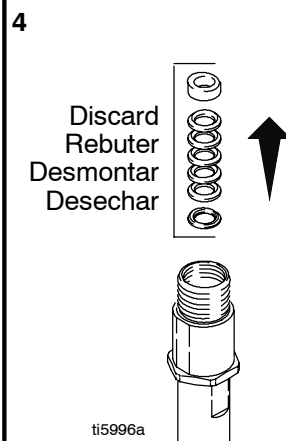
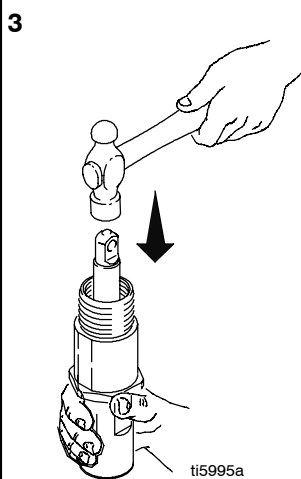
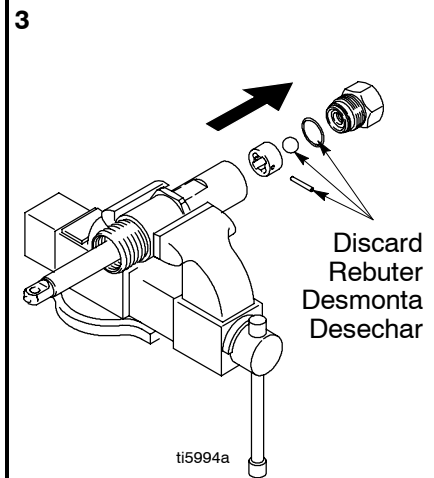
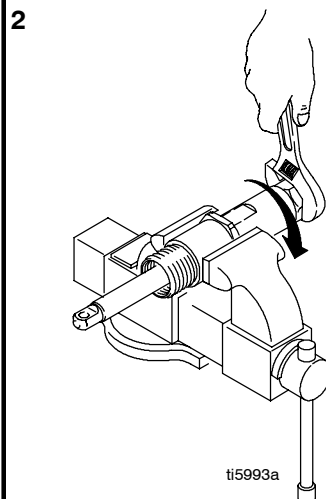
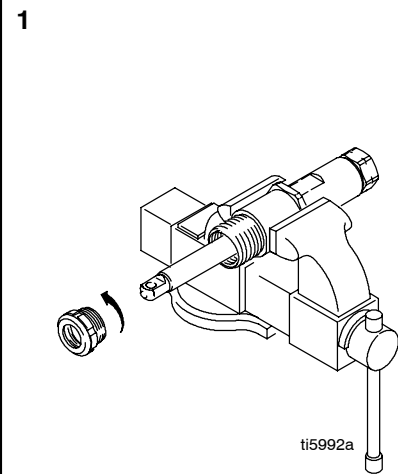

DISASSEMBLE / DÉMONTAGE / DESMONTAGEM / DESARMADO

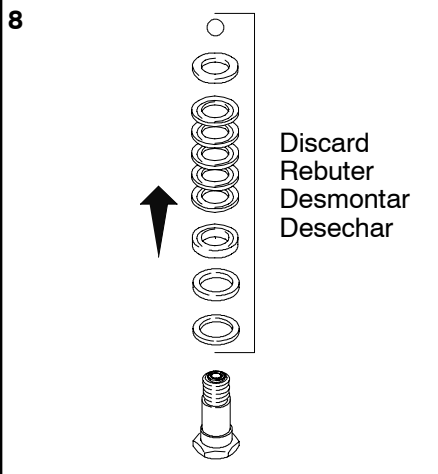
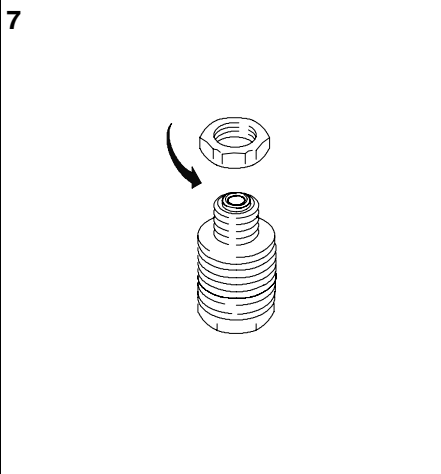
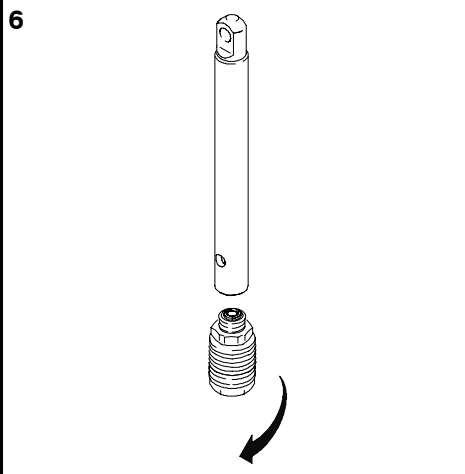

ASSEMBLE / MONTAGE / MONTAGEM / ARMADO

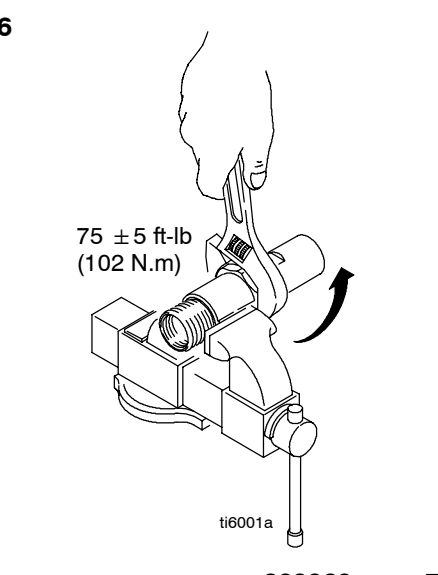
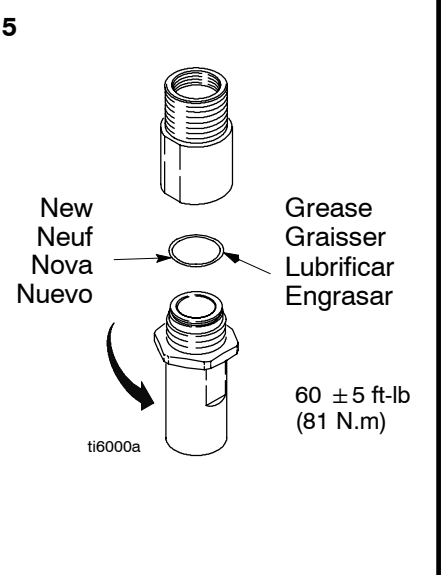
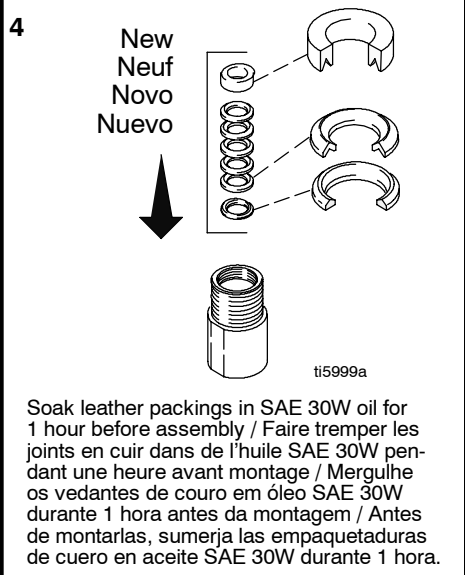
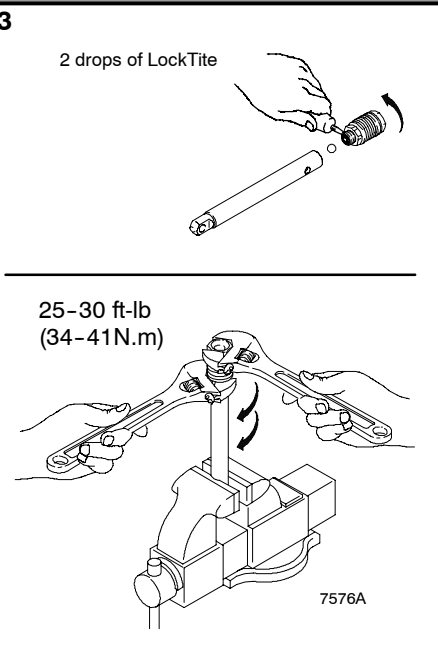
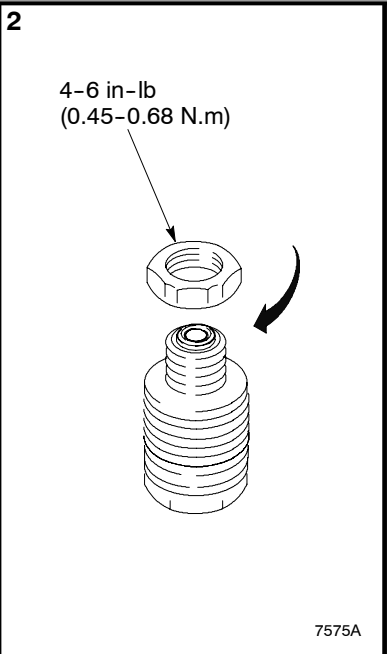
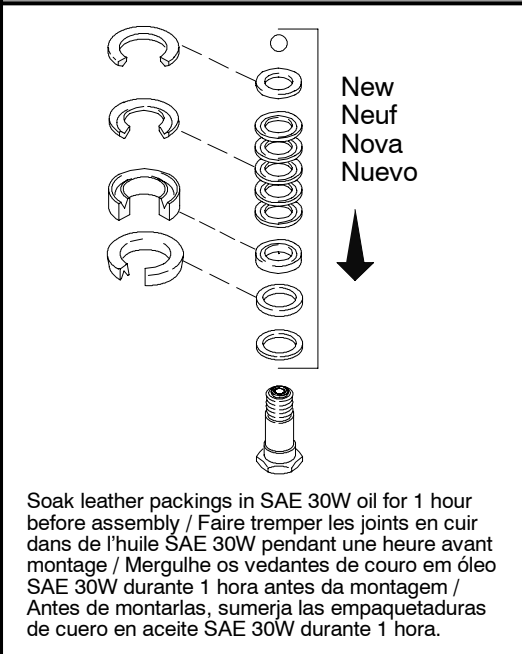

ASSEMBLE / MONTER / MONTAGEM / ARMADO

7

Install loosely
Monter sans serrer
Apertar ligeiramente
Instale, pero sin apretar

ti6002a

8

Grease
Graisser
Lubrificar
Engrasar

9

Grease Top 2 in.
Graisser le haut sur 2 in.
Lubrificar 2 pol. da parte superior
Engrasar las 2 pulg. superiores

10

ti6003a

11

Screw in packing nut until it stops against packings; then continue tightening 1/4-1/2 turn / Visser l'écrou de presse-étoupe jusqu'à ce qu'il soit en butée contre les joints; serrer encore de 1/4-1/2 tour / Aperte a porca de vedação até que esta encoste bem aos vedantes; depois, continue a apertar 1/4-1/2 de volta / Enrosque la tuerca prensaestopas hasta que tropiece contra las empaquetaduras; después siga apretando 1/4-1/2 de vuelta.

Install new
Installez nouveau
Instale novo
Instale nuevo

ti6004a

12

60 ± 5 ft-lb (81 N.m)

ti6005a

13 Storage / Entreposage
Armazenamento / Almacenamiento

THROAT PACKING ADJUSTMENT / RÉGLAGE DU PRESSE-ÉTOUPE / AJUSTE DE APERTO DOS EMPANQUES / AJUSTE DE LAS EMPAQUETADURAS DEL CUELLO

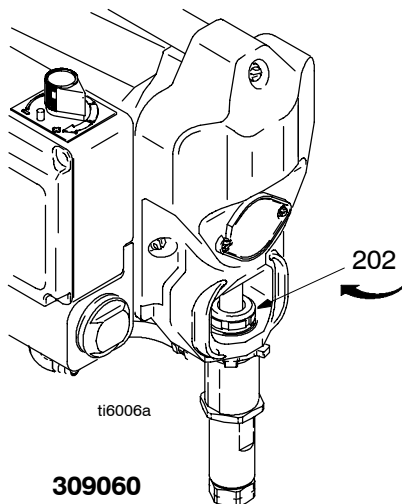

When pump begins to leak after much use. Then tighten packing nut (202) down until leakage stops or lessens. This allows approximately 100 gallons of additional operation before a repacking is required.

Quand la pompe commencer à fuir après une longue période d'utilisation, resserrer l'écrou de presse-étoupe (202) jusqu'à ce que la fuite soit résorbée ou réduite. Cela permet de prolonger le fonctionnement de 376 litres environ avant de changer les joints.

Quando a bomba começar a apresentar fugas após uma utilização intensiva, aperte a porca de vedação (202) até que a fuga pare ou diminua. Isto permite aproximadamente 376 litros de utilização adicional antes que seja necessária uma nova vedação.

Quando la bomba comienza a presentar fugas después de funcionar durante mucho tiempo. En tal caso, apriete la tuerca prensaestopas (202) hasta que las fugas desaparezcan o disminuyan. Esto permite que pueda seguir bombeando aproximadamente 376 litros antes de que sea necesario volver a poner nuevas empaquetaduras.

Parts / Pièces / Peças / Piezas

Model 243187, Series A / Modèle 243187, série A & B / Modelo 243187, série A & B / Modelo 243187, serie A & B

Includes items 101 to 126 / Comprenant les rep. 101 à 126 / Inluis os itens 101 a 126 / Incluye los ítems 101 a 126

Ref.No.	Part No.	Description	Qty
101	243179	DISPLACEMENT ROD	1
102	180656	PLUG	1
103	193047	PACKING NUT	1
104	243180	PUMP MANIFOLD	1
105	187614	JAM NUT, 1-3/8-18 unef-2b	1
106	176757*†	GLAND, female, throat	1
107	176997*†	V-PACKING, UHMW polyethylene, throat	3
108	176755*†	V-PACKING, leather, throat	2
109	176754*†	GLAND, male, throat	1
110	176750*†	GLAND, male, piston	1
111	176749*†	V-PACKING, leather, piston	2
112	176882*†	V-PACKING, UHMW polyethylene, piston	3
113	180073*†	GLAND, female, piston	1
114	105522*†	PACKING, u-cup, polyurethane	1
115	186652*†	WASHER, backup, steel	1
116	218197†	PISTON VALVE	1
117	105444*†	BALL, 5/16", piston	1
118	108526*†	PACKING, o-ring, PTFE	1
119	235708	CYLINDER, pump	1
120	224966	INLET VALVE	1
121	105445*†	INLET BALL, 1/2"	1
122	111603*†	PACKING, o-ring, PTFE	1
123	176760	BALL GUIDE	1
124	176759*†	BALL STOP PIN	1
125	176751†	NUT, hex, 1/2-20 unf-2b	1
126	102969*†	SEALANT (not shown)	1
225	162453	NIPPLE, 1/4 npsm x 1/4 npt	1

*Supplied in Repair Kit 243091
 Fourni avec le kit de réparation 243091
 Fornecido no kit de reparacão 243091
 Suministrado en el kit de reparacón 243091

†Supplied in Repair Kit 287078
 Fourni avec le kit de réparation 287078
 Fornecido no kit de reparacão 287078
 Suministrado en el kit de reparacón 287078

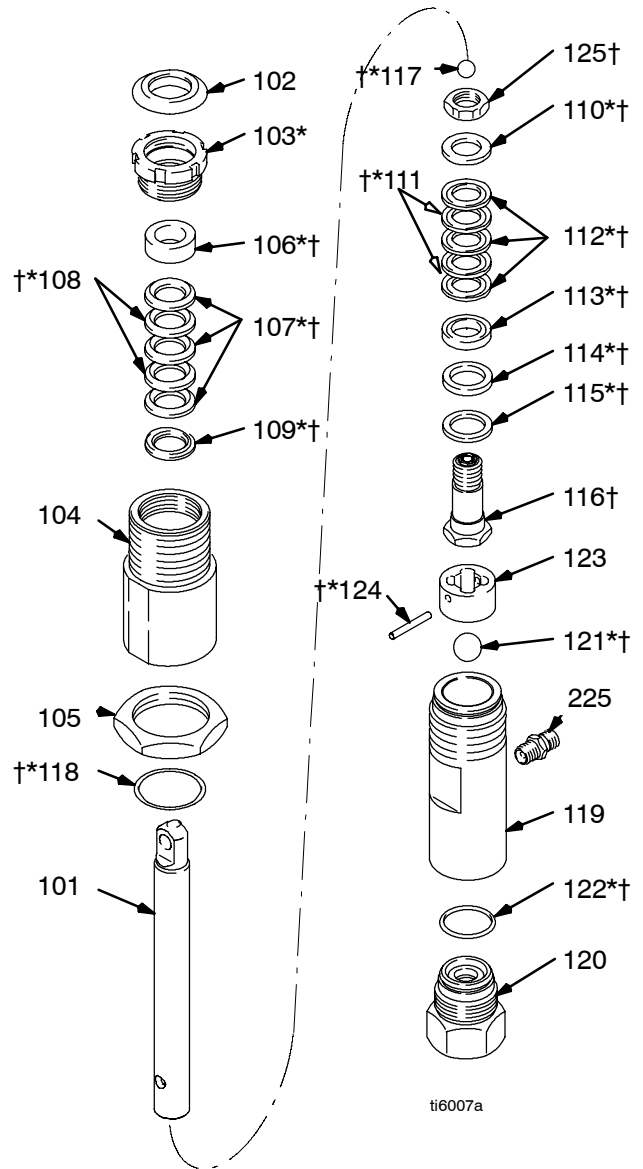

Technical Data / Caractéristiques techniques/ Dados técnicos / Características técnicas

Maximum working pressure / Pression de service maximum / Pressão máxima de trabalho // Presión máxima de	3000 psi (207 bar, 20.7 MPa)
Fluid inlet size / Entrée produit / Dimensão da entrada de líquido / Tamaño de la entrada de fluido	3/4 npt(f)
Fluid outlet size / Sortie produit / Dimensão da saída de líquido / Tamaño de la salida de fluido	1/4 npt(f)
Wetted parts	stainless steel, PTFE, leather, polyurethane, zinc-plated carbon steel, tungsten carbide, chrome plating, UHMWPE, Delrin®, polyethylene
Pièces en contact avec le produit	acier inox, PTFE, cuir, polyuréthane, acier au carbone galvanisé, carbure de tungstène, revêtement chromé, UHMWPE, Delrin®, polyéthylène
Peças em contacto com o produto	aço inoxidável, PTFE, couro, poliuretano, aço carbono zincado, carboneto de tungsténio, cromagem, UHMWPE, Delrin®, polietileno
Piezas húmedas	acero inoxidable, PTFE, cuero, poliuretano, acero al carbono revestido de zinc, carburo de tungsteno, cromado, UHMWPE, Delrin®, polietileno

NOTE: Delrin® is a registered trademark of the Du Pont Company. Loctite® is a registered trademark of the Loctite Company.

REMARQUE: Delrin® est une marque déposée de la société Du Pont Company. Loctite® est une marque déposée de la société Loctite Company.

NOTA: Delrin® é uma marca registada Du Pont Company. Loctite® é uma marca registada da Loctite Company.

NOTA: Delrin® es una marca registrada de Du Pont Company. Loctite® es una marca registrada de Loctite Company.

Graco Standard Warranty

Garantie Graco standard

Garantia Standard da Graco

Garantía estándar de Graco

Graco warrants all equipment referenced in this document which is manufactured by Graco and bearing its name to be free from defects in material and workmanship on the date of sale by an authorized Graco distributor to the original purchaser for use. With the exception of any special, extended, or limited warranty published by Graco, Graco will, for a period of twelve months from the date of sale, repair or replace any part of the equipment determined by Graco to be defective. This warranty applies only when the equipment is installed, operated and maintained in accordance with Graco's written recommendations.

This warranty does not cover, and Graco shall not be liable for general wear and tear, or any malfunction, damage or wear caused by faulty installation, misapplication, abrasion, corrosion, inadequate or improper maintenance, negligence, accident, tampering, or substitution of non-Graco component parts. Nor shall Graco be liable for malfunction, damage or wear caused by the incompatibility of Graco equipment with structures, accessories, equipment or materials not supplied by Graco, or the improper design, manufacture, installation, operation or maintenance of structures, accessories, equipment or materials not supplied by Graco.

This warranty is conditioned upon the prepaid return of the equipment claimed to be defective to an authorized Graco distributor for verification of the claimed defect. If the claimed defect is verified, Graco will repair or replace free of charge any defective parts. The equipment will be returned to the original purchaser transportation prepaid. If inspection of the equipment does not disclose any defect in material or workmanship, repairs will be made at a reasonable charge, which charges may include the costs of parts, labor, and transportation.

THIS WARRANTY IS EXCLUSIVE, AND IS IN LIEU OF ANY OTHER WARRANTIES, EXPRESS OR IMPLIED, INCLUDING BUT NOT LIMITED TO WARRANTY OF MERCHANTABILITY OR WARRANTY OF FITNESS FOR A PARTICULAR PURPOSE.

Graco's sole obligation and buyer's sole remedy for any breach of warranty shall be as set forth above. The buyer agrees that no other remedy (including, but not limited to, incidental or consequential damages for lost profits, lost sales, injury to person or property, or any other incidental or consequential loss) shall be available. Any action for breach of warranty must be brought within two (2) years of the date of sale.

GRACO MAKES NO WARRANTY, AND DISCLAIMS ALL IMPLIED WARRANTIES OF MERCHANTABILITY AND FITNESS FOR A PARTICULAR PURPOSE, IN CONNECTION WITH ACCESSORIES, EQUIPMENT, MATERIALS OR COMPONENTS SOLD BUT NOT MANUFACTURED BY GRACO. These items sold, but not manufactured by Graco (such as electric motors, switches, hose, etc.), are subject to the warranty, if any, of their manufacturer. Graco will provide purchaser with reasonable assistance in making any claim for breach of these warranties.

In no event will Graco be liable for indirect, incidental, special or consequential damages resulting from Graco supplying equipment hereunder, or the furnishing, performance, or use of any products or other goods sold hereto, whether due to a breach of contract, breach of warranty, the negligence of Graco, or otherwise.

FOR GRACO BRAZILIAN/CANADIAN/COLUMBIAN CUSTOMERS

The Parties acknowledge that they have required that the present document, as well as all documents, notices and legal proceedings entered into, given or instituted pursuant hereto or relating directly or indirectly hereto, be drawn up in English.

À L'ATTENTION DES CLIENTS BRÉSILIENS/CANADIENS/COLOMBIENS DE GRACO

Les parties reconnaissent avoir convenu que la rédaction du présente document sera en Anglais, ainsi que tous documents, avis et procédures judiciaires exécutés, donnés ou intentés à la suite de ou en rapport, directement ou indirectement, avec les procédures concernées.

PARA CLIENTES BRASILEIROS/CANADIANOS/COLOMBIANOS DA GRACO

As partes confirmam que solicitaram que o presente documento, assim como todos os demais documentos, notas e processos legais inseridos, atribuídos ou instituídos de acordo com o mesmo ou relacionados directa ou indirectamente com este documento, fossem redigidos em inglês.

PARA LOS CLIENTES EN BRASIL/CANADÁ/COLOMBIA

Las partes reconocen haber convenido que el presente documento, así como todos los documentos, notificaciones y procedimientos judiciales emprendidos, presentados o establecidos que tengan que ver con estas garantías directa o indirectamente, estarán redactados en inglés.

ADDITIONAL WARRANTY COVERAGE / AVENANT DE GARANTIE / COBERTURA DE GARANTIA ADICIONAL / COBERTURA ADICIONAL DE LA GARANTÍA

Graco does provide extended warranty and wear warranty for products described in the “Graco Contractor Equipment Warranty Program”.

Graco accorde une garantie étendue et se porte garant des produits décrits dans le “Programme de garantie d’équipements des fournisseurs Graco”.

A Graco fornece prorrogação de garantia e garantia de desgaste para os produtos descritos no “Graco Contractor Equipment Warranty Program” (Programa de garantia de equipamento Contractor da Graco).

Graco proporciona una garantía extendida y una garantía que cubre el desgaste de los productos descritos en el “Programa de Garantía del Equipo Contractor de Graco”.

TO PLACE AN ORDER OR FOR SERVICE, contact your Graco distributor,
or call 1-888-541-9788 to identify the nearest distributor.

POUR PASSER COMMANDE OU DEMANDER UNE PRESTATION D’ENTRETIEN, contactez votre distributeur Graco.

PARA EFECTUAR ENCOMENDAS OU PARA ASSISTÊNCIA TÉCNICA, contacte o seu distribuidor da Graco.

PARA REMITIR UN PEDIDO O SOLICITAR SERVICIO, póngase en contacto con el distribuidor de Graco.

All written and visual data contained in this document reflects the latest product information available at the time of publication. Graco reserves the right to make changes at any time without notice.

Toutes les données écrites et visuelles figurant dans ce document reflètent les toutes dernières informations disponibles au moment de sa publication. Graco se réserve le droit de procéder à des modifications à tout moment sans avis préalable.

Todo o texto e desenhos contidos neste documento reflectem as mais recentes informações sobre o produto disponíveis na altura da publicação.

A Graco reserva-se o direito de efectuar alterações em qualquer momento sem aviso prévio.

Todos los datos, escritos y visuales, contenidos en este documento reflejan la información más reciente sobre el producto disponible en el momento de su publicación, Graco se reserva el derecho de realizar cambios en cualquier momento, sin previo aviso.

Sales Offices: Minneapolis
International Offices: Belgium, Korea, Hong Kong, Japan
Bureaux des ventes: Minneapolis
Bureaux à l’étranger: Belgique, Corée, Hong-Kong, Japon
Escritórios de Vendas: Minneapolis
Escritórios estrangeiros: Bélgica, Coreia, Hong Kong, Japão
Oficinas de vendas: Minneapolis
Oficinas en el extranjero: Bélgica, Corea, Hong Kong, Japón

GRACO INC. P.O. BOX 1441 MINNEAPOLIS, MN 55440-1441

<http://www.graco.com>

PRINTED IN USA 309060 10/1999, Revised 11/2007
IMPRIMÉ AUX É.-U. 309060 10/1999, Révisé 11/2007
IMPRESO EN EE.UU. 309060 10/1999, Revisado 11/2007
IMPRESSO NOS EUA 309060 10/1999, Revisado 11/2007