

G-Max[®] 7900 Airless Paint Sprayer

308870G

EN

For Portable Airless Spraying of Architectural Coatings and Paints.

3300 psi (227 bar, 22.7 MPa) Maximum Working Pressure

Models

NOTE: All models are not available in all countries.

Model	Series	Description
232630	B	Hi-Boy
232631	B	Hi-Boy with RAC 5 tip, gun and hose
232632	B	Lo-Boy
232633	B	Lo-Boy with RAC 5 tip, gun and hose
233008	A	Hi-Boy with Gauge Kit



Important Safety Instructions

Read all warnings and instructions in this manual. Save these instructions.

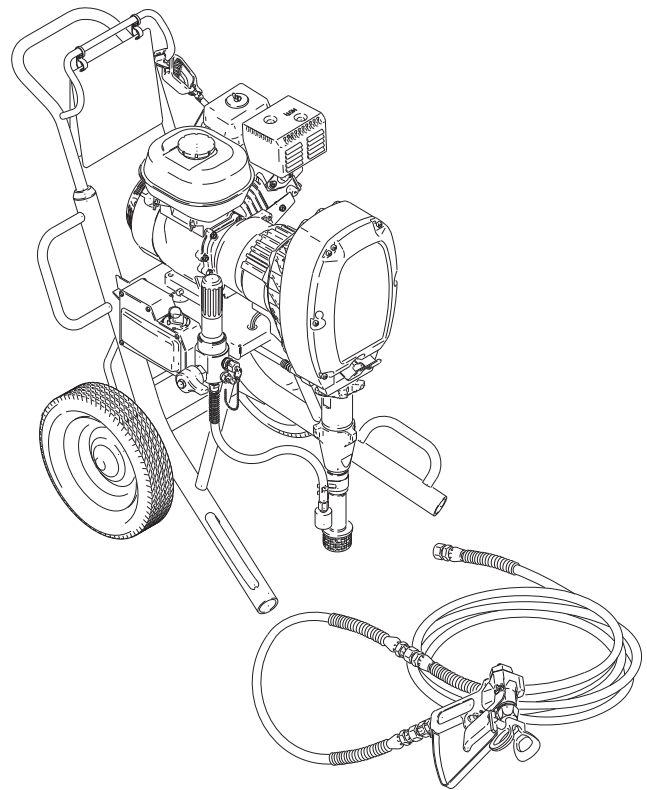

Related Manuals



Manual	Manual Number
Operation	308867
Displacement Pump	307898
Spray Gun	309091
Spray Tip	309055
PC Board	308919
Drain Valve Kit	308961

Table of Contents

Warnings	3
Component Identification	5
Maintenance	6
Pressure Relief Procedure	6
Troubleshooting	7
Pinion Assembly / Rotor / Field / Shaft / Clutch	13
Clamp	15
Engine	16
On / Off Switch	17
Pressure Control	18
Control Board	18
Pressure Control Transducer	19
Pressure Adjust Potentiometer	20
Control Board Diagnostics	21
Displacement Pump	22
Pump Pin Clip	23
Parts List & Drawing - Pinion Assembly	24
Parts Drawing - Hi-Boy Sprayer	25
Model 232630 and 233008	25
Parts List - Hi-Boy Sprayers	26
Models 232630, 232631 and 233008*	26
Parts Drawing - Lo-Boy Sprayer	28
Model 232632, 232633	28
Parts List - Lo-Boy Sprayers	29
Models 232632, 232633	29
Model 232630 through 232633	31
Parts List - Hi-Boy Sprayers	32
Models 232630 through 232633	32
Parts List - Complete Sprayers	33
Models 232631, 232633	33
Displacement Pump Repair Kit	33
Danger Labels	33
Wiring Diagram	34
Technical Data	35
Model 232630, 232631, 232008	35
Model 232632, 232633	35
Graco Warranty	36

Warnings

The following warnings are for the setup, use, grounding, maintenance, and repair of this equipment. The exclamation point symbol alerts you to a general warning and the hazard symbols refer to procedure-specific risks. When these symbols appear in the body of this manual or on warning labels, refer back to these Warnings. Product-specific hazard symbols and warnings not covered in this section may appear throughout the body of this manual where applicable.

<h1>WARNING</h1>	
	<p>FIRE AND EXPLOSION HAZARD</p> <p>Flammable fumes, such as solvent and paint fumes, in work area can ignite or explode. To help prevent fire and explosion:</p> <ul style="list-style-type: none"> • Use equipment only in well ventilated area. • Do not fill fuel tank while engine is running or hot; shut off engine and let it cool. Fuel is flammable and can ignite or explode if spilled on hot surface. • Eliminate all ignition sources; such as pilot lights, cigarettes, portable electric lamps, and plastic drop cloths (potential static arc). • Keep work area free of debris, including solvent, rags and gasoline. • Do not plug or unplug power cords, or turn power or light switches on or off when flammable fumes are present. • Ground all equipment in the work area. See Grounding instructions. • Use only grounded hoses. • Hold gun firmly to side of grounded pail when triggering into pail. Do not use pail liners unless they are antistatic or conductive. • Stop operation immediately if static sparking occurs or you feel a shock. Do not use equipment until you identify and correct the problem. • Keep a working fire extinguisher in the work area.
	<p>SKIN INJECTION HAZARD</p> <p>High-pressure spray is able to inject toxins into the body and cause serious bodily injury. In the event that injection occurs, get immediate surgical treatment.</p> <ul style="list-style-type: none"> • Do not aim the gun at, or spray any person or animal. • Keep hands and other body parts away from the discharge. For example, do not try to stop leaks with any part of the body. • Always use the nozzle tip guard. Do not spray without nozzle tip guard in place. • Use Graco nozzle tips. • Use caution when cleaning and changing nozzle tips. In the case where the nozzle tip clogs while spraying, follow the Pressure Relief Procedure for turning off the unit and relieving the pressure before removing the nozzle tip to clean. • Do not leave the unit energized or under pressure while unattended. When the unit is not in use, turn off the unit and follow the Pressure Relief Procedure for turning off the unit. • Check hoses and parts for signs of damage. Replace any damaged hoses or parts. • This system is capable of producing 3000 psi (210 bar/21 MPa). Use Graco replacement parts or accessories that are rated a minimum of 3000 psi (210 bar/21 MPa). • Always engage the trigger lock when not spraying. Verify the trigger lock is functioning properly. • Verify that all connections are secure before operating the unit. • Know how to stop the unit and bleed pressure quickly. Be thoroughly familiar with the controls.

WARNING



EQUIPMENT MISUSE HAZARD

Misuse can cause death or serious injury.

- Do not operate the unit when fatigued or under the influence of drugs or alcohol.
- Do not exceed the maximum working pressure or temperature rating of the lowest rated system component. See **Technical Data** in all equipment manuals.
- Use fluids and solvents that are compatible with equipment wetted parts. See Technical Data in all equipment manuals. Read fluid and solvent manufacturer's warnings. For complete information about your material, request MSDS from distributor or retailer.
- Do not leave the work area while equipment is energized or under pressure. (
- Turn off all equipment and follow the **Pressure Relief Procedure** when equipment is not in use.
- Check equipment daily. Repair or replace worn or damaged parts immediately with genuine manufacturer's replacement parts only.
- Do not alter or modify equipment. Alterations or modifications may void agency approvals and create safety hazards.
- Make sure all equipment is rated and approved for the environment in which you are using it.
- Use equipment only for its intended purpose. Call your distributor for information.
- Route hoses and cables away from traffic areas, sharp edges, moving parts, and hot surfaces.
- Do not kink or over bend hoses or use hoses to pull equipment.
- Keep children and animals away from work area.
- Comply with all applicable safety regulations.



PERSONAL PROTECTIVE EQUIPMENT

Wear appropriate protective equipment when in the work area to help prevent serious injury, including eye injury, hearing loss, inhalation of toxic fumes, and burns. This protective equipment includes but is not limited to:

- Protective eyewear, and hearing protection.
- Respirators, protective clothing, and gloves as recommended by the fluid and solvent manufacturer

Component Identification

202 Main hose
 203 Whip end hose
 204 Contractor gun with RAC 5
 DripLess tip guard and 517 size SwitchTip

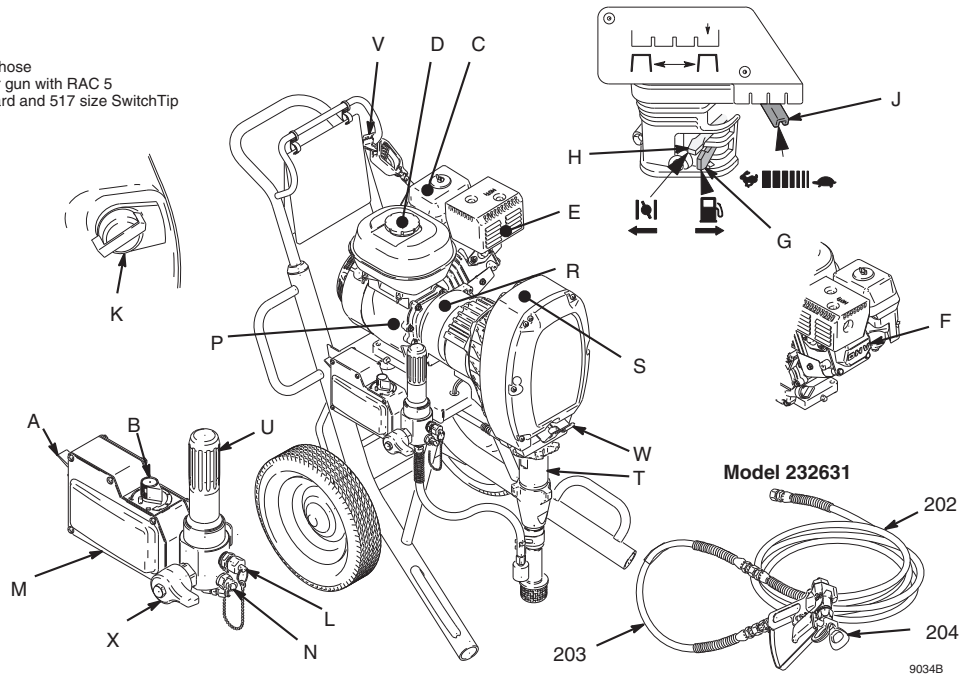

A	Pressure Control Switch	ON/OFF, enables/disables clutch function and pressure control
B	Pressure Adjusting Knob	Controls fluid outlet pressure
C	Air Cleaner*	Filters air entering the carburetor
D	Fuel Tank*	Uses 86 octane unleaded gasoline
E	Muffler*	Reduces noise of internal combustion
F	Spark Plug Cable*	Routes electrical current to spark plug
G	Fuel Shutoff Lever*	On/off lever to regulate fuel flow from gasoline tank to carburetor
H	Choke*	Enriches air/gasoline mixture for cold starting
J	Throttle Lever*	Adjusts engine speed for large or small orifice spray tips
K	Engine Switch*	Enables/disables engine operation
L	Secondary Fluid Outlet	Second hose and spray gun is connected here
M	Pressure Control	Controls clutch cycling to maintain fluid pressure
N	Primary Fluid Outlet	Hose and spray gun is connected here
P	Engine*	4-cycle gasoline engine
R	Clutch Housing	Transfers power from engine to drive assembly
S	Drive Housing	Transfers power from clutch to displacement pump
T	Displacement Pump	Provides fluid to be sprayed through spray gun
U	Fluid Filter	Filters fluid between source and spray gun
V	Grounding Clamp and Wire	Grounds sprayer system
W	Pail Hanger	Provides a hanger for paint pail
X	Drain Valve	Relieves fluid pressure when open

* For more detailed explanations of these controls, refer to the Honda Engines Owner's Manual; supplied.

Maintenance

NOTE: For detailed engine maintenance and specifications, refer to separate Honda Engines Owner's Manual, supplied.

Pressure Relief Procedure



Follow the Pressure Relief Procedure whenever you see this symbol.



This equipment stays pressurized until pressure is manually relieved. To help prevent serious injury from pressurized fluid, such as skin injection, splashing fluid and moving parts, follow the Pressure Relief Procedure when you stop spraying and before cleaning, checking, or servicing the equipment.

1. Engage trigger lock.
2. Turn ON/OFF switch to OFF.
3. Move pressure control switch to OFF and turn pressure control knob fully counterclockwise.
4. Unlock trigger safety. Hold metal part of gun firmly to side of grounded metal pail, and trigger gun to relieve pressure.
5. Lock gun trigger safety.
6. Open the pressure drain valve. Leave the pressure drain valve open until you are ready to spray again.
7. If you suspect the spray tip or hose is clogged or that pressure has not been fully relieved after following the steps above, **VERY SLOWLY** loosen tip guard retaining nut or hose end coupling to relieve pressure gradually, then loosen completely. Clear hose or tip obstruction.

Maintenance Checklist

- **DAILY:** Check engine oil level and fill as necessary.
- **DAILY:** Check hose for wear and damage.
- **DAILY:** Check gun safety for proper operation.
- **DAILY:** Check pressure drain valve for proper operation.
- **DAILY:** Check and fill the gas tank.

AFTER THE FIRST 20 HOURS OF OPERATION:

- Drain engine oil and refill with clean oil. Reference Honda Engines Owner's Manual for correct oil viscosity.
- **WEEKLY:** Remove air filter cover and clean element. Replace element, if necessary. If operating in an unusually dusty environment: check filter daily and replace, if necessary.

Replacement elements can be purchased from your local HONDA dealer.

- **WEEKLY:** Check level of TSL in displacement pump packing nut. Fill nut, if necessary. Keep TSL in nut to help prevent fluid buildup on piston rod and premature wear of packings.

AFTER EACH 100 HOURS OF OPERATION:

- Change engine oil. Reference Honda Engines Owner's Manual for correct oil viscosity.

SPARK PLUG:

- Use only BPR6ES (NGK) or W20EPR-U (NIPPON-DENSO) plug. Gap plug to 0.028 to 0.031 in. (0.7 to 0.8 mm).
- Use spark plug wrench when installing and removing plug.

Troubleshooting

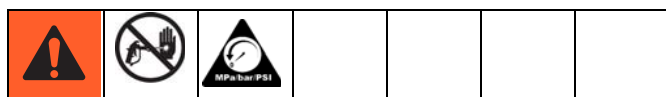

Problem	Cause	Solution
Engine won't start	Engine switch is OFF	Turn engine switch ON
	Engine is out of gas	Refill gas tank. Honda Engines Owner's Manual.
	Engine oil level is low	Try to start engine. Replenish oil, if necessary. Honda Engines Owner's Manual.
	Spark plug cable is disconnected or damaged	Connect spark plug cable or replace spark plug
	Cold engine	Use choke
	Fuel shutoff lever is OFF	Move lever to ON position
	Oil is seeping into combustion chamber	Remove spark plug. Pull starter rope 3 or 4 times. Clean or replace spark plug. Try to start engine. Keep sprayer upright to avoid oil seepage.
Engine operates, but displacement pump does not operate	Pressure control switch is OFF	Turn pressure control switch ON.
	Pressure setting is too low	Turn pressure adjusting knob clockwise to increase pressure
	Fluid filter (318) is dirty	Clean filter. Page 31.
	Tip or tip filter is clogged	Clean tip or tip filter. Manual 309091.
	Displacement pump piston rod is stuck due to dried paint	Repair pump. Manual 308798.
	Roller bearings are worn or damaged	Replace connecting rod. Page 10.
	Drive housing is worn or damaged	Replace drive housing. Page 10.

Problem	Cause	Solution
Engine operates, but displacement pump does not operate (continued)	Electrical power is not energizing clutch field	<p>Check wiring connections. Page 15. Reference control board diagnostics. Page 21.</p> <p>With pressure control switch ON and pressure turned to MAXIMUM, use a test light to check for power between clutch terminals on control board.</p> <p>Remove black clutch wires from control board and measure resistance across wires. At 70_ F, the resistance must be between 1.7 +0.2W; if not, replace clutch coil 241121.</p> <p>Have pressure control checked by authorized Graco dealer.</p>
	Clutch is worn or damaged	Replace clutch. Page 13.
	Pinion assembly is worn or damaged	Repair or replace pinion assembly. Page 13.
Pump output is low	Strainer (31) is clogged	Clean strainer
	Piston ball (25) is not seating	Service piston ball. Manual 308798.
	Piston packings are worn or damaged	Replace packings. Manual 308798.
	O-ring (227) in displacement pump is worn or damaged	Replace o-ring. Manual 308798.
	Intake valve ball is not seating properly	Clean intake valve. manual 308798.
	Engine speed is too low	Increase throttle setting. Manual 308867.
	Clutch is worn or damaged	Replace clutch. Page 13.
	Pressure setting is too low	Increase pressure. Manual 308867.
	Fluid filter (318), tip filter or tip is clogged or dirty	Clean filter. Manual 308867 or 309091.
Large pressure drop in hose with heavy materials	Use larger diameter hose and/or reduce overall length of hose. Use of more than 100 ft of 1/4 in. hose significantly reduces performance of sprayer. Use 3/8 in. hose for optimum performance (50 ft minimum).	

Problem	Cause	Solution
Excessive paint leakage into throat packing nut	Throat packing nut is loose	Remove throat packing nut spacer. Tighten throat packing nut just enough to stop leakage.
	Throat packings are worn or damaged	Replace packings. Manual 308798.
	Displacement rod is worn or damaged	Replace rod. Manual 308798.
Fluid is spitting from gun	Air in pump or hose	Check and tighten all fluid connections. Reprime pump. Manual 308867.
	Tip is partially clogged	Clear tip. Manual 309091.
	Fluid supply is low or empty	Refill fluid supply. Prime pump. Manual 308867. Check fluid supply often to prevent running pump dry.
Pump is difficult to prime	Air in pump or hose	Check and tighten all fluid connections. Reduce engine speed and cycle pump as slowly as possible during priming.
	Intake valve is leaking	Clean intake valve. Be sure ball seat is not nicked or worn and that ball seats well. Reassemble valve.
	Pump packings are worn	Replace pump packings. Manual 308798.
	Paint is too thick	Thin the paint according to the supplier's recommendations.
	Engine speed is too high	Decrease throttle setting before priming pump. Manual 308867.
Clutch squeaks each time clutch engages	Clutch surfaces are not matched to each other when new and may cause noise	Clutch surfaces need to wear into each other. Noise will dissipate after a day of run time.
Engine stalls	Engine speed is too slow	- Increase throttle setting. - Adjust engine speed at no load to 3750 - 3850 rpm
	Fluid filter is clogged	Relieve pressure and clean filter
	Too much pump friction (new pump)	Reduce pressure to 3000 psi (20.68 MPa, 206.8 bar) until pump wears in
	Spark plug wire is loose	Reconnect wire

Rollers

Removal



1. Relieve pressure, page 6.
2. Remove six cap screws (10) lock washers (9) and cover assembly (24) (FIG. 1).

NOTE: A screw driver may be needed to pry off cover assembly.

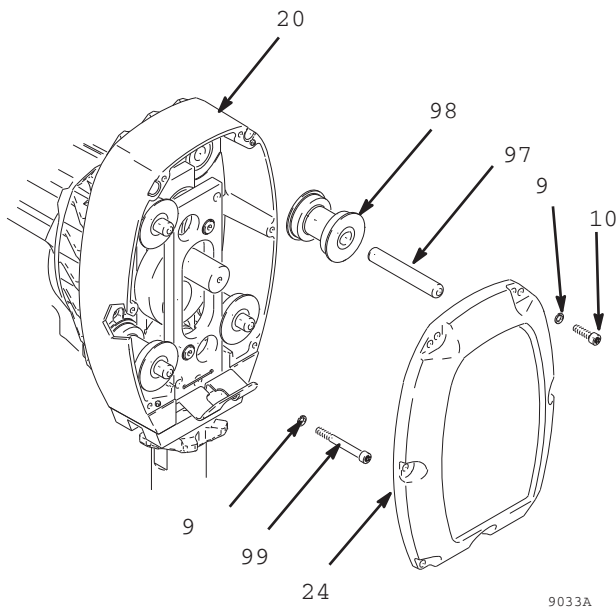

FIG. 1

3. Remove dowel pins (97) and rollers (98).

Installation

1. Install rollers (98) and dowel pins (97).
2. Install cover assembly (24) with six lock washers (9) and cap screws (10).

Drive Housing

Removal



1. Relieve pressure, page 6.
2. Remove six cap screws (10) lock washers (9) and cover assembly (24) (FIG. 1).
3. Remove two screws (99) and washers (9).
4. Remove four cap screws (10) lock washers (9) from drive housing (20).
5. Lightly tap around drive housing (20) to loosen drive housing. Pull drive housing straight off pinion housing. Be prepared to support gear cluster (18), which may also come out.

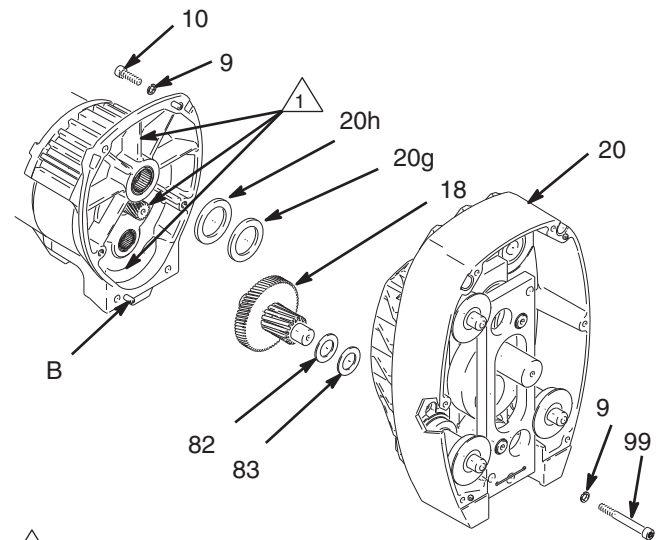

△ Apply remaining grease to these areas
FIG. 2

Installation

1. Liberally apply bearing grease (supplied with replacement gear cluster) to gear cluster (18), washers (82) and (83) (FIG. 2, page 10) and to areas called out by note 1. Use full 0.68 pint (0.32 liter) of grease for GMax 7900.
2. Place bronze colored washer (83) and silver colored washer (82) (FIG. 2, page 10) onto drive housing (20). Install gear cluster (18) through washers (83) and (82).
3. Place bronze colored washer (20g) and silver colored washer (20h) on shaft protruding from large shaft of drive housing (20) (FIG. 2, page 10). Align gears and push new drive housing straight onto pinion housing and locating pins (B).
4. Install two washers (9) and screws (99) (FIG. 2, page 10).
5. Install four lock washers (9) and cap screws (10) into drive housing (20) (FIG. 2, page 10).
6. Install cover assembly (24) with six lock washers (9) and cap screws (10) (FIG. 2, page 10).

Cam Follower Bearings

Removal

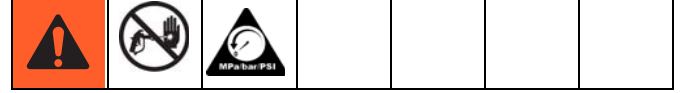

1. Relieve pressure, page 6.
2. Cycle pump piston rod (222) to lowest position (FIG. 3). Turn engine off.

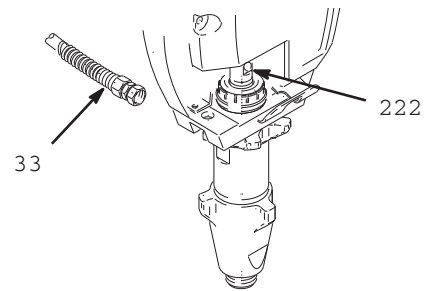

FIG. 3

NOTE: All Steps refer to FIG. 4.

3. Remove six cap screws (10), lock washers (9) and cover assembly (24) (FIG. 4, page 12).

NOTE: A screw driver may be needed to pry off cover assembly.

4. Remove four dowel pins (97) and rollers (98) (FIG. 4, page 12).
5. From front, drive out pump pin (101) with a screw driver (FIG. 4, page 12).
6. Remove two retainer rings (20d) (FIG. 4, page 12).
7. Remove cam follower plate (20b) (FIG. 4, page 12).

NOTE: Two 1/2 in. x 13 bolts may be needed to remove cam follower plates.

8. Remove two cam follower bearings (20c) (FIG. 4, page 12).

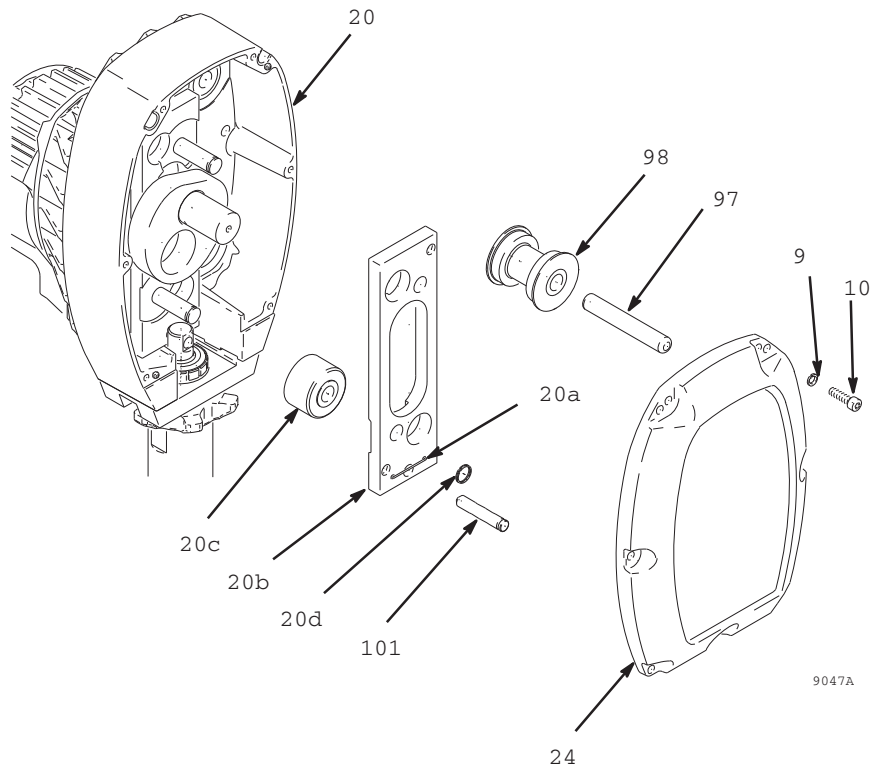

FIG. 4

Installation

NOTE: All Steps refer to FIG. 4.

1. Install two cam follower bearings (20c).
2. Install cam follower plate (20b).
3. Install two retainer rings (20d).
4. Drive in pump pin (101) until it engages with pump pin retaining clip (20a).
5. Install four rollers (98) and dowel pin (97).
6. Install cover assembly (24) with six lock washers (9) and cap screws (10).

Pinion Assembly / Rotor / Field / Shaft / Clutch

Removal

If pinion assembly (19) is not removed from clutch housing (5), do 1. through 4. Otherwise, start at 5.



1. Relieve pressure, page 6.
2. Disconnect field cable (X) from pressure control and engine lead (FIG. 5).

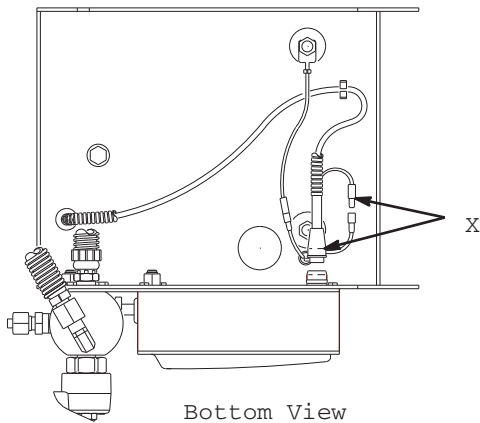

9027A

FIG. 5

3. Remove five screws (26) and lock washers (17) and pinion assembly (19) (FIG. 6).

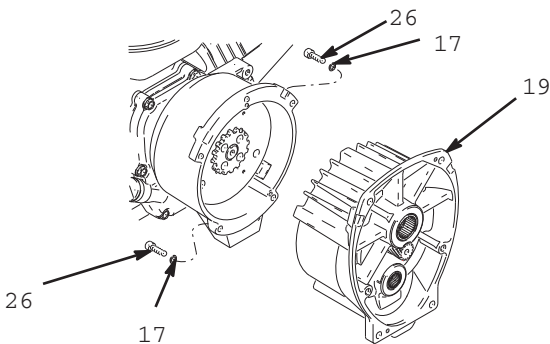

9029A

FIG. 6

4. Place pinion assembly (19) on bench with rotor side up.
5. Remove four screws (72) and lock washers (17). Install two screws in threaded holes (E) in rotor. Alternately tighten screws until rotor comes off (FIG. 7).

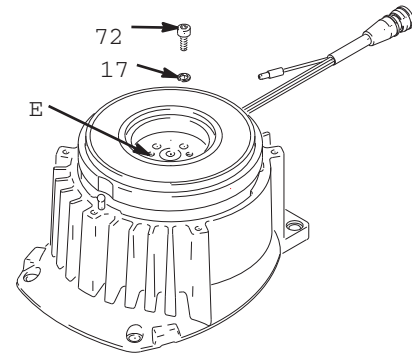

903C

FIG. 7

6. Remove retaining ring (19e) (FIG. 8).
7. Tap pinion shaft (19d) out with plastic mallet (FIG. 8).

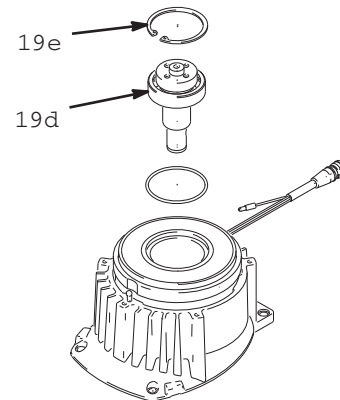
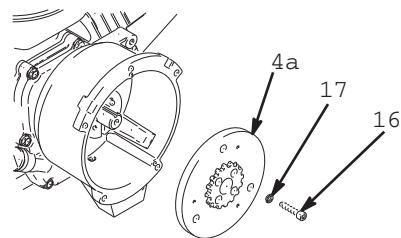

FIG. 8

8. Use an impact wrench or wedge something between armature (4a) and clutch housing to hold engine shaft during removal (FIG. 9).
9. Remove four screws (16) and lock washers (17) (FIG. 9).
10. Remove armature (4a) (FIG. 9).



9028A

FIG. 9

Installation

1. Lay two stacks of two dimes on smooth bench surface.
2. Lay armature (4a) on two stacks of dimes (FIG. 10).
3. Press center of clutch down on bench surface.

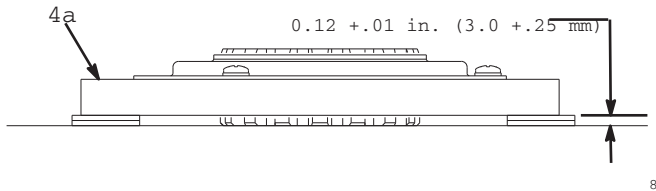

FIG. 10

4. Install armature (4a) on engine drive shaft.
5. Install four screws (16) and lock washers (17) with torque of 125 in-lb (14 N.m).
6. Tap pinion shaft (19d) in with plastic mallet (FIG. 11).

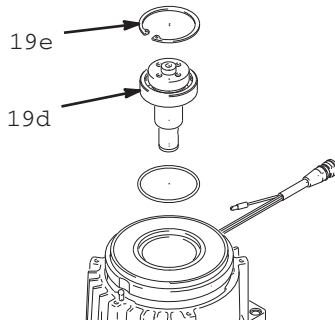

FIG. 11

7. Install retaining ring (19e) with beveled side facing field.
8. Place pinion assembly on bench with rotor side up (FIG. 12).

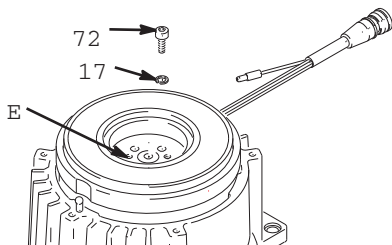

FIG. 12

9. Apply Locktite®¹ to screws. Install four screws (16) and lock washers (17) (FIG. 13). Alternately torque screws to 125 in-lb (14 N.m) until rotor is secure. Use threaded holes to hold rotor.

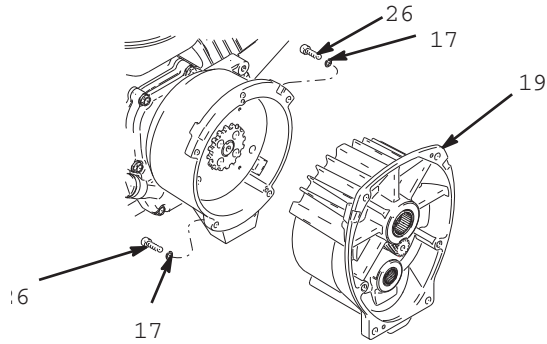

FIG. 13

10. Install pinion assembly (19) with five screws (10) and lock washers (9) (FIG. 13).
11. Connect field cable (X) to pressure control and engine lead (FIG. 14).

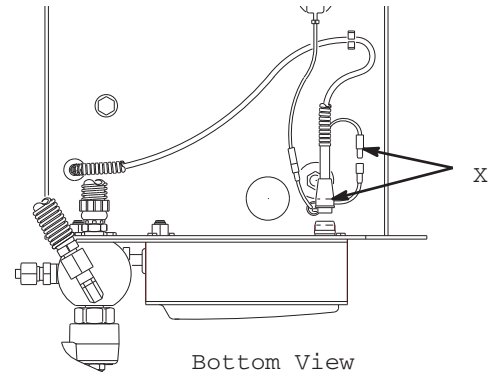

FIG. 14

¹.Locktite® is a registered trademark of Henkel.

Clamp

Removal

NOTE: All Steps refer to FIG. 15.

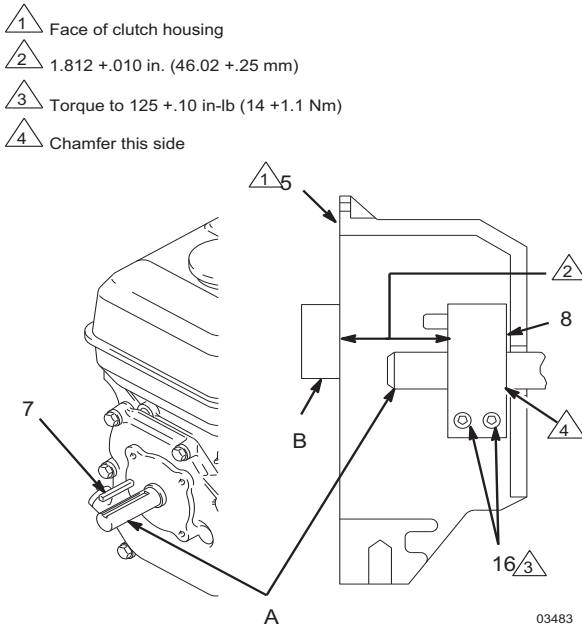

FIG. 15

1. Loosen two screws (16) on clamp (8).
2. Push screwdriver into slot in clamp (8) and remove clamp.

Installation

NOTE: All Steps refer to FIG. 15.

1. Install engine shaft key (7).
2. Tap clamp (8) on engine shaft (A) with plastic mallet.
3. Press clamp (8) onto engine shaft (A). Maintain dimension shown note 2 in Fig. 12. Chamfer side must face engine.

Check dimension: Place rigid, straight steel bar (B) across face of clutch housing (5). Use accurate measuring device to measure distance between bar and face of clamp. Adjust clamp as necessary. Torque two screws (16) to 125 +10 in-lb (14 +1.1 N.m).

Clutch Housing

Removal

NOTE: All Steps refer to FIG. 16.

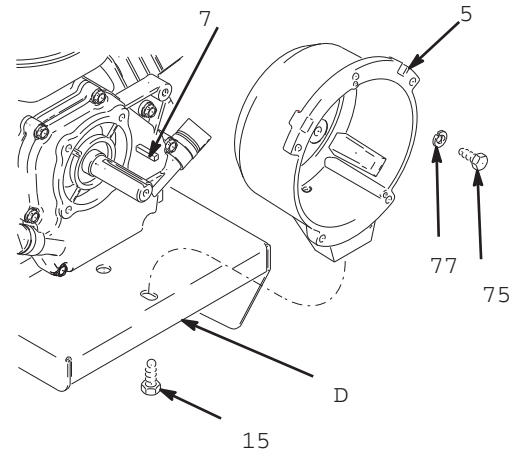

FIG. 16

1. Remove four cap screws (75) and lock washers (77) which hold clutch housing (5) to engine.
2. Remove screw (15) from under mounting plate (D).
3. Remove engine key (7).
4. Pull off clutch housing (5)

Installation

NOTE: All Steps refer to FIG. 16.

1. Push on clutch housing (5).
2. Install four cap screws (75) and lock washers (77) and secure clutch housing (5) to engine. Torque to 200 in-lb (22.6 N.m).
3. Install cap screw (15) from beneath mounting plate (D). Torque to 26 ft-lb (35.2 N.m).

Engine

Removal

1. Remove Pinion Assembly/Rotor/Field/Pinion/Clutch, Clamp and Clutch Housing. See instructions beginning on pages 13.
2. Disconnect all necessary wiring (FIG. 17).

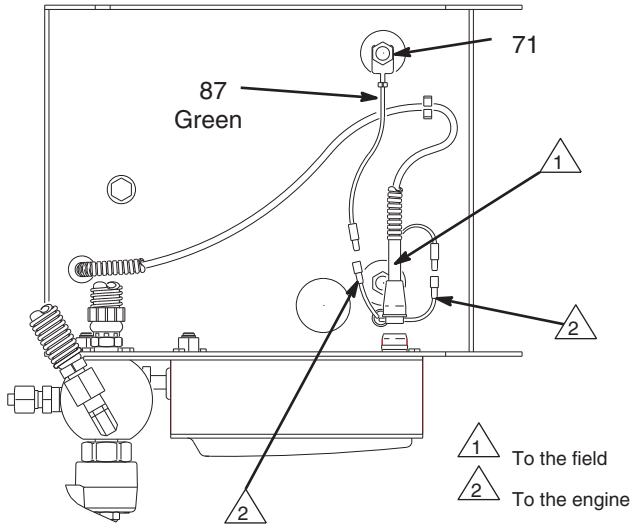

FIG. 17

3. Remove two lock nuts (71) and screws (70) from base of engine (FIG. 17).
4. Lift engine carefully and place on work bench.

NOTE: All service to the engine must be performed by an authorized HONDA dealer.

Installation

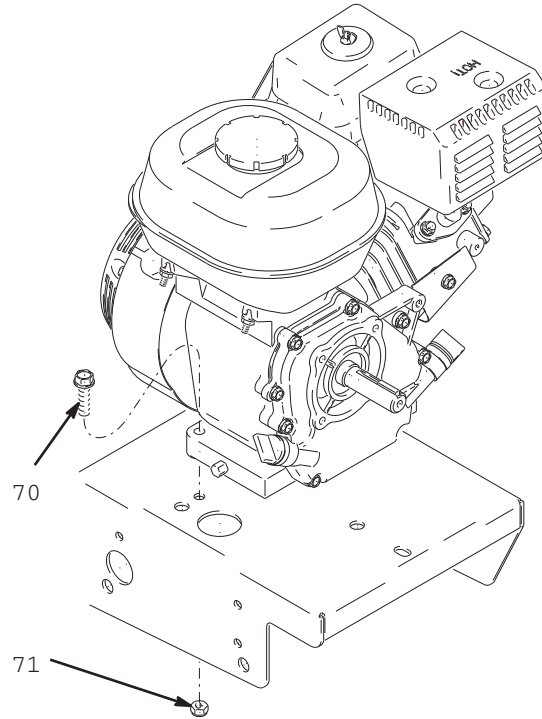

FIG. 18

1. Lift engine carefully and place on cart (FIG. 18).
2. Install two screws (70) in base of engine and secure with lock nuts (71) (FIG. 18). Torque to 200 in-lb (22.6 N.m).
3. Connect all necessary wiring (FIG. 17).
4. Install Pinion Assembly/Rotor/Field/Pinion/Clutch, Clamp and Clutch Housing, as instructed on page 14.

On / Off Switch

NOTE: All Steps refer to FIG. 19.

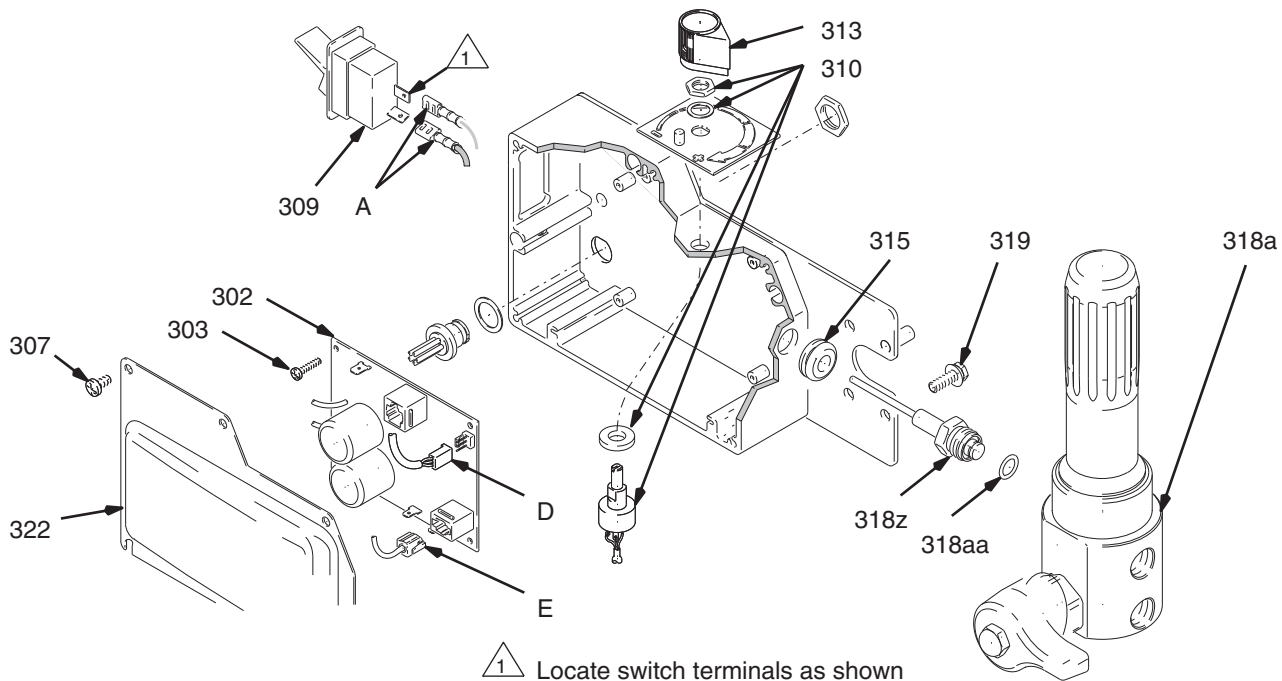
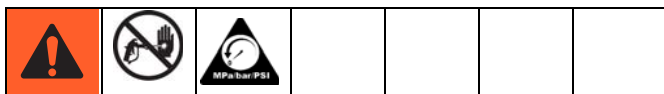

FIG. 19

Removal



1. Relieve pressure, page 6.
2. Remove five screws (307) and cover (322).
3. Disconnect two wires (A) from ON/OFF switch (309).
4. Press in on two retaining tabs on each side of ON/OFF switch (309) and remove switch.

Installation

1. Install new ON/OFF switch (309) so tabs of switch snap into place on inside of pressure control housing.
2. Connect two wires (A) to ON/OFF switch.
3. Install pressure control cover (322) with five screws (307).

Pressure Control

Control Board

NOTE: All Steps refer to FIG. 20.

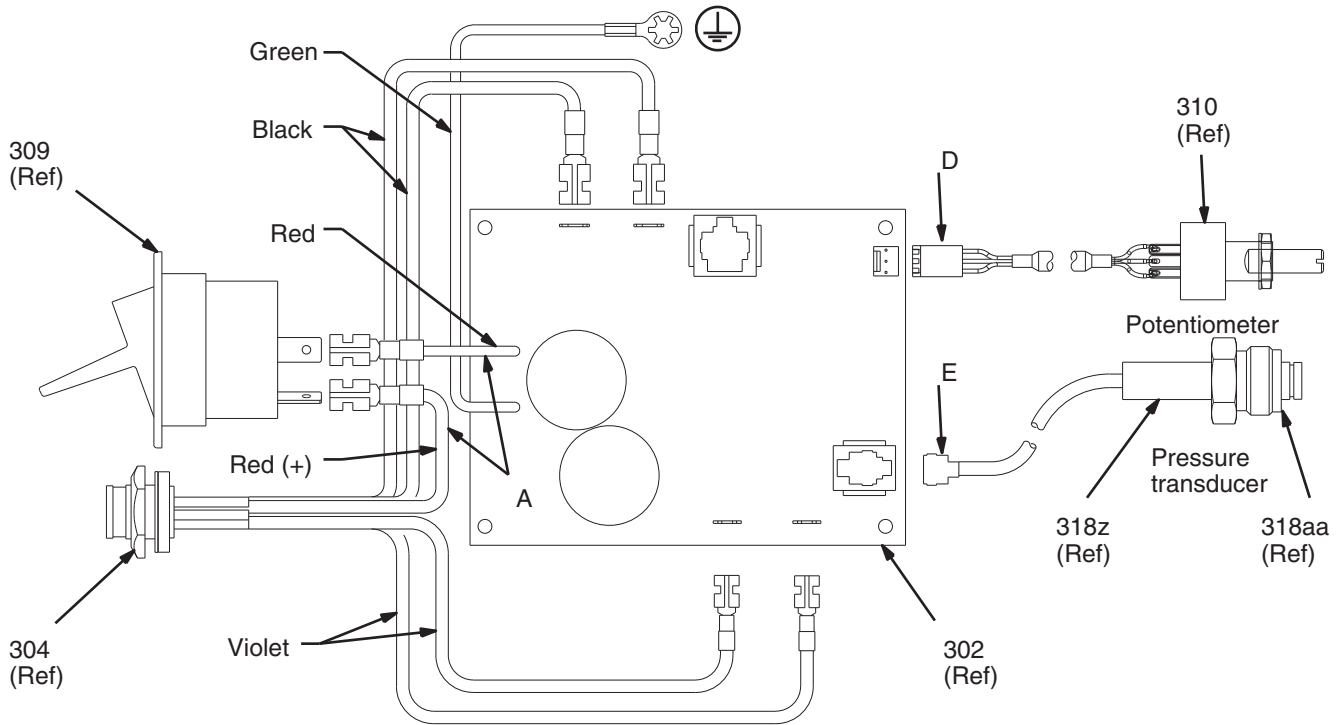
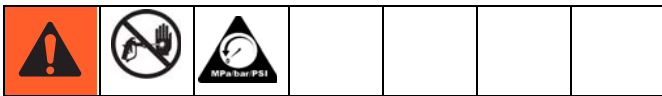

FIG. 20

Removal



1. Relieve pressure, page 6.
2. Remove five screws (307) and cover (322).
3. Disconnect at control board (302):
 - Four clutch leads: two violet and two black.
 - Lead (D) from potentiometer.
 - Lead (E) from transducer.
 - Two red leads (A) to ON/OFF switch (309).
4. Remove five screws (303), green ground wire and control board (302).

Installation

When installing replacement control board, follow instructions with control board to set model type.

1. Install green ground wire and control board (302) with five screws (303).
2. Connect to control board (302):
 - Two red leads (A) to ON/OFF switch (309).
 - Lead (E) to transducer.
 - Lead (D) to potentiometer.
 - Four clutch leads: two violet and two black.
3. Fig. 16. Install cover (322) with five screws (307).

Pressure Control Transducer

NOTE: All Steps refer to FIG. 21.

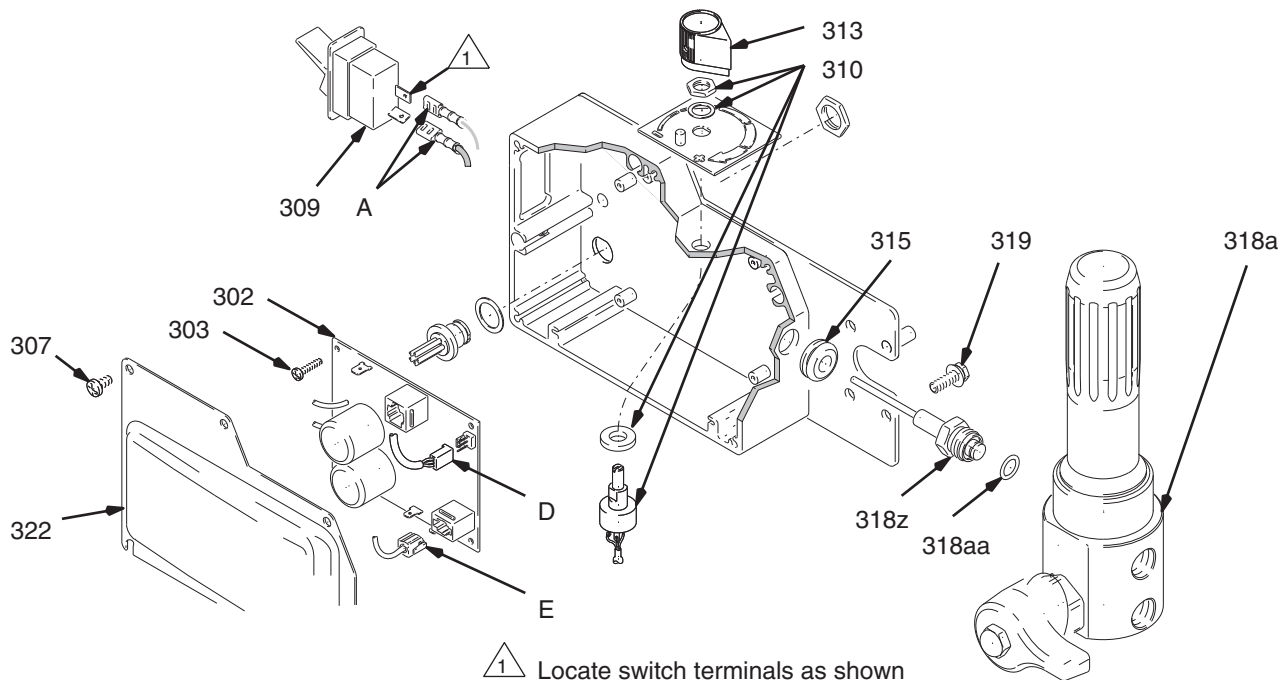
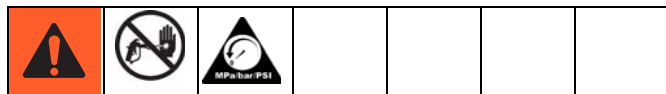

FIG. 21

Removal



1. Relieve pressure, page 6.
2. Remove five screws (307) and cover (322).
3. Disconnect lead (E) from control board (302).
4. Remove three screws (319) and fluid filter (318) from control plate (301). Carefully pull transducer connector through rubber grommet (315).
5. Remove pressure control transducer (318z) and packing o-ring (318aa) from filter housing (318a).

Installation

1. Install packing o-ring (318aa) and pressure control transducer (318z) in filter housing (318a). Torque to 30-35 ft-lb.
2. Carefully feed transducer connector through rubber grommet (315). Install fluid filter (318) on control plate (301) with three screws (319).
3. Connect lead (E) to motor control board (302).
4. Install cover (322) with five screws (307).

Pressure Adjust Potentiometer

NOTE: All Steps refer to FIG. 22.

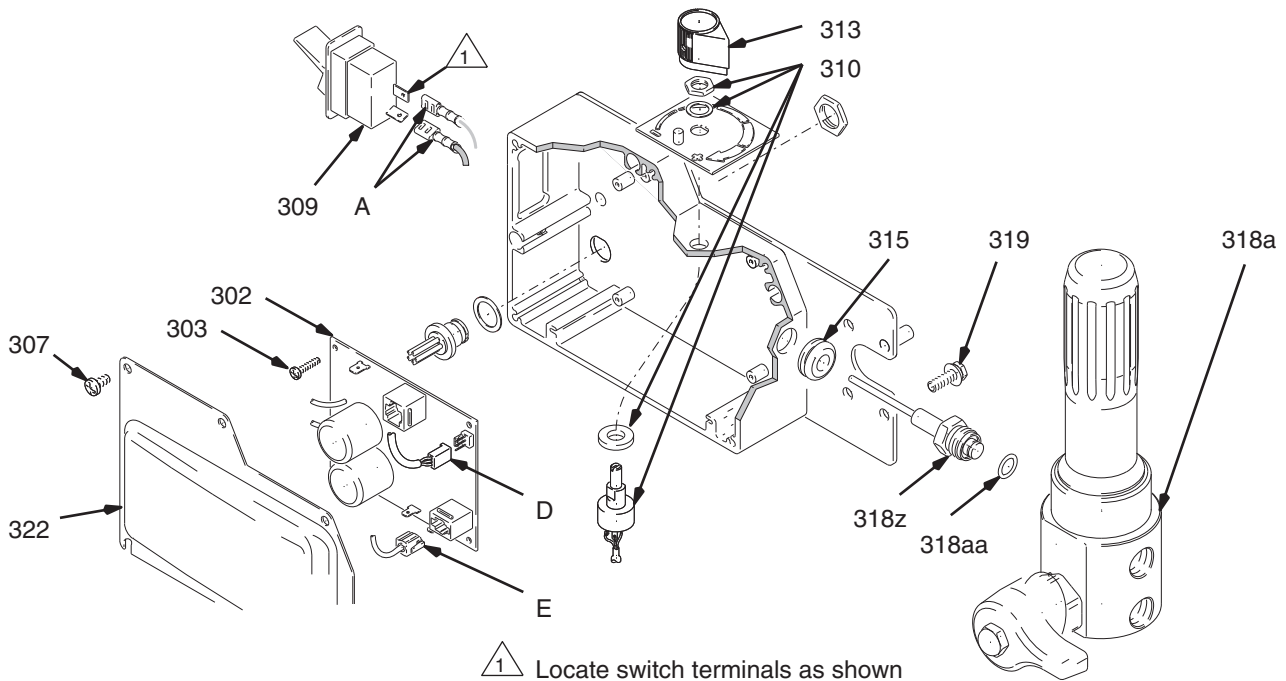
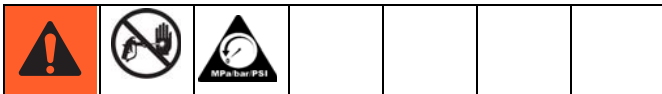

FIG. 22

Removal



1. Relieve pressure, page 6.
2. Remove five screws (307) and cover (322).
3. Disconnect lead (D) from control board (302).
4. Loosen set screws on potentiometer knob (313) and remove knob, shaft nut, lockwasher (310) and pressure adjust potentiometer (310).
5. Remove seal (311) from potentiometer (310)

Installation

1. Install seal (311) on potentiometer (310).
2. Install pressure adjust potentiometer (310), shaft nut, lock washer (310) and potentiometer knob (313).
 - a. Turn potentiometer shaft (310) clockwise to internal stop. Assemble potentiometer knob (313) to strike pin on plate (312).
 - b. After adjustment of step a., tighten both set screws in knob 1/4 to 3/8 turn after contact with shaft.
3. Connect lead (D) to control board (302).
4. Install cover (322) with five screws (307).

Control Board Diagnostics

1. Remove five screws (307) and cover (322) (FIG. 22).
2. Start sprayer.
3. Turn ON/OFF switch ON.
4. Observe LED operation and reference following table:

LED Blinks	Sprayer Operation	Indicates	What to do
Two times repeatedly	Sprayer shuts down and LED continues to blink two times repeatedly	Run away pressure. Pressure greater than 4500 psi (310 bar, 31 MPa)	<ol style="list-style-type: none"> 1. Check pressure transducer connection at control board. 2. Replace pressure transducer. 3. Replace control board.
Three times repeatedly	Sprayer shuts down and LED continues to blink three times repeatedly	Pressure transducer is faulty or missing	<ol style="list-style-type: none"> 1. Check pressure transducer connection at control board. 2. Replace pressure transducer. 3. Replace control board.
Four times repeatedly	Sprayer shuts down and LED continues to blink four times repeatedly	Generator voltage is low	<ol style="list-style-type: none"> 1. Increase engine throttle. 2. Check wiring connections. 3. Service Honda engine alternator.
Five times repeatedly	Sprayer shuts down and LED continues to blink five times repeatedly	High clutch current	<ol style="list-style-type: none"> 1. Check clutch 5-pin bulkhead connector. Clean contacts. 2. Measure $1.7 \pm 0.2\Omega$ across clutch field at 70°F (21°C). 3. Replace clutch field assembly.
Six times repeatedly	Sprayer shuts down and LED continues to blink six times repeatedly	High clutch temperature	<ol style="list-style-type: none"> 1. If clutch is new, let sprayer cool down and then restart 2. Inspect clutch. Replace clutch if there is excessive wear. 3. Remove pump pin, separate pinion housing from clutch housing. Rotate rotor clockwise to check for excessive drag.

Displacement Pump

Removal

1. Flush pump.
2. Cycle pump with piston rod (222) in lowest position (FIG. 23).

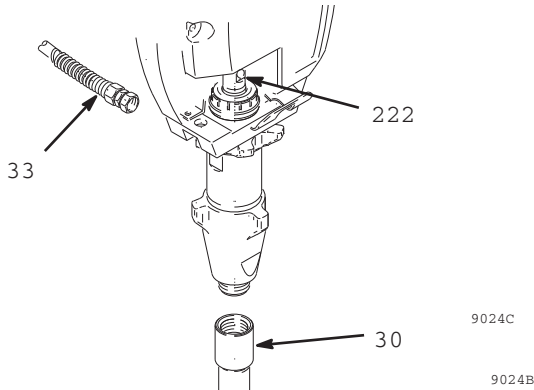

FIG. 23



3. Relieve pressure, page 6.
4. Remove suction tube (30) and hose (33).
5. Use screwdriver to push out pump pin (101) (FIG. 24).

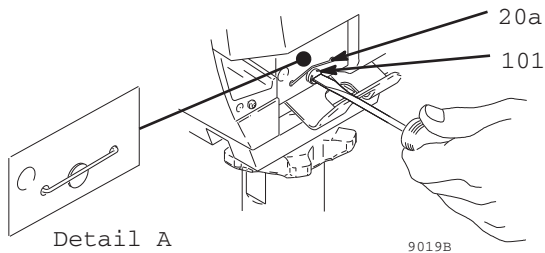

FIG. 24

6. Loosen locknut by hitting firmly with a 20 oz (maximum) hammer (FIG. 25). Unscrew pump.

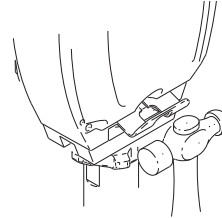

FIG. 25

NOTE: See manual 308798 for pump repair instructions.

Installation

!						
<p>If pin works loose, parts could break off due to force of pumping action. Parts could project through the air and result in serious injury or property damage. Make sure pin (101) and retaining clip (20a) are properly installed. See Detail A. Fig. 18.</p>						

NOTICE
<p>If the pump locknut loosens during operation, the threads of the bearing housing will be damaged. Make sure locknut is properly tightened.</p>

1. Pull piston rod out 1.0 in. Screw in pump until holes in housing plates and piston rod align (FIG. 26).

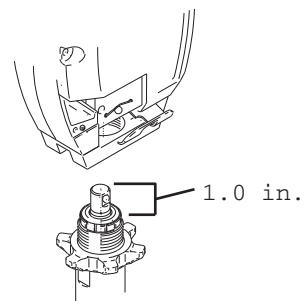
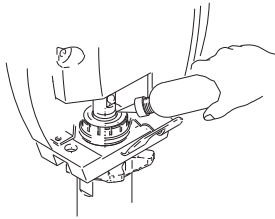

FIG. 26

2. See Detail A (FIG. 24). Push pin (101) into hole until retaining clip (20a) snaps over pin.

3. Screw jam nut down onto pump until nut stops. Screw pump up into pump plate until it stops. Back off pump one full turn and align pump outlet to back.
4. Tighten jam nut by hand, then tap 1/8 to 1/4 turn with a 20 oz (maximum) hammer to approximately 75 +5 ft-lb (102 Nm) (FIG. 27).
5. Fill packing nut with Graco TSL until fluid flows onto the top of seal.



90

FIG. 27

Pump Pin Clip

Removal

1. Remove pump (28).
2. Remove two bolts (86), washers (25), pump bracket (85), pail hook (94) and shield (95).
3. Remove clip (20a).

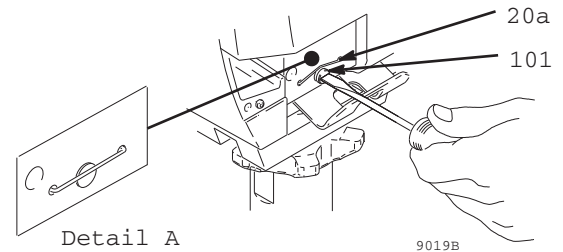
**FIG. 28**

Installation

1. Install clip (20a) (FIG. 28).
2. Install shield (95), pail hook (94) and pump bracket (85) with two washers (25) and bolts (86). Torque bolts to 40 ft-lb (54 NSm).
3. Install pump (28).

Parts List & Drawing - Pinion Assembly

Ref No. 19 and 20

Ref No. 19: Pinion Housing Assembly 241116

Ref	Part No.	Description	Qty
19a	241121	PINION HOUSING, coil	1
19b	105489	PIN	2
19d	241114	PINION SHAFT	
19e	112770	RETAINING RING, large	
20		DRIVE HOUSING	1
21a	194060	RETAINING CLIP, pump pin	1

Ref	Part No.	Description	Qty
20b	193656	CAM FOLLOWER PLATE	1
20c	114691	CAM FOLLOWER BEARING	2
20d	114828	RETAINER CLIP	2
20g	114697	WASHER	1
20h	114698	WASHER	1
101	195528	PIN	1

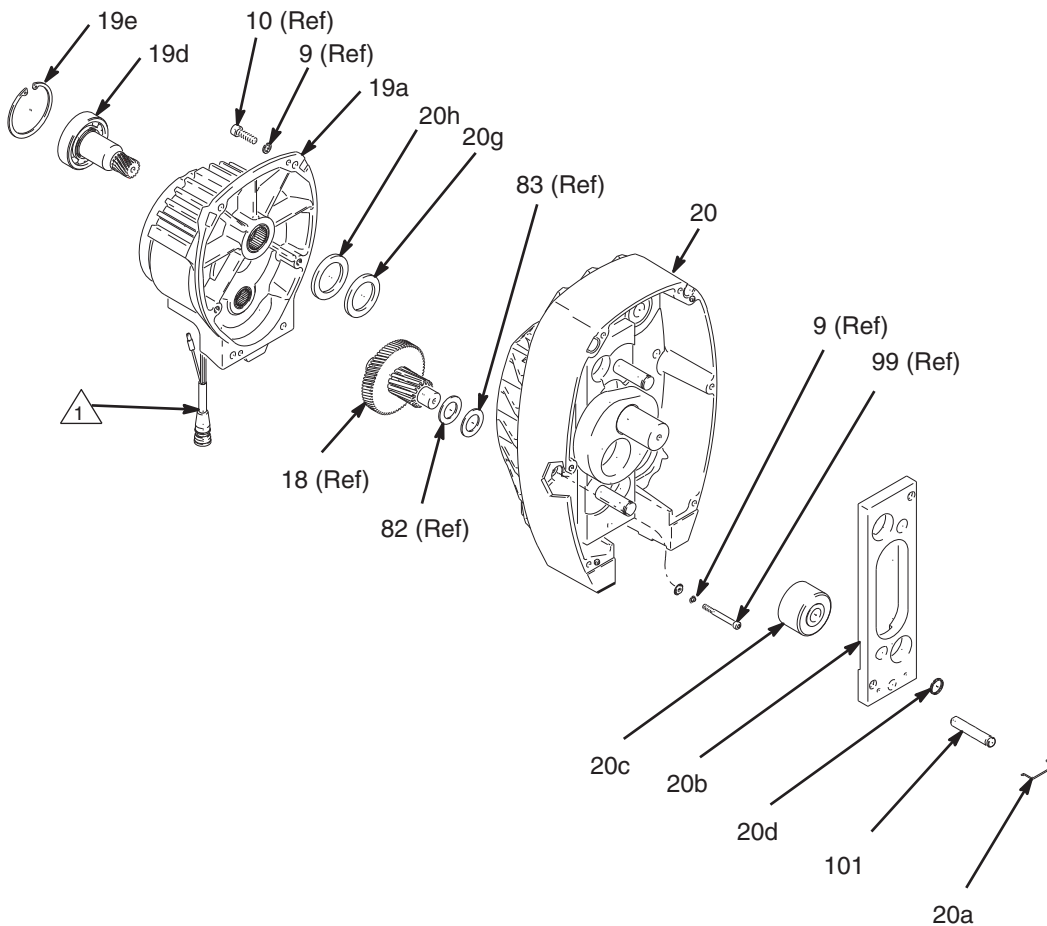

Parts Drawing - Hi-Boy Sprayer

Model 232630 and 233008

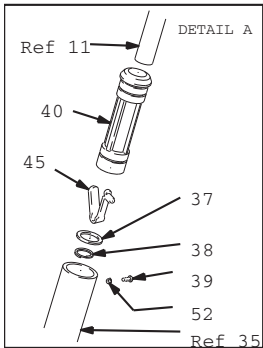

- 1 Label
- 2 See page 17 for the parts.
- 3 See manual 308798 for the parts.
- 4 See page 22 for the parts.
- 5 See page 22 for the parts.

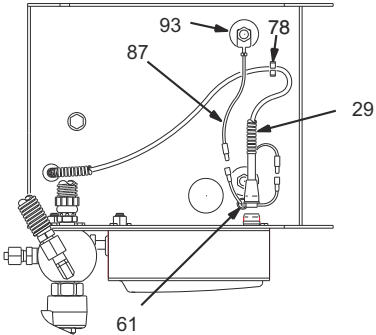

9027A

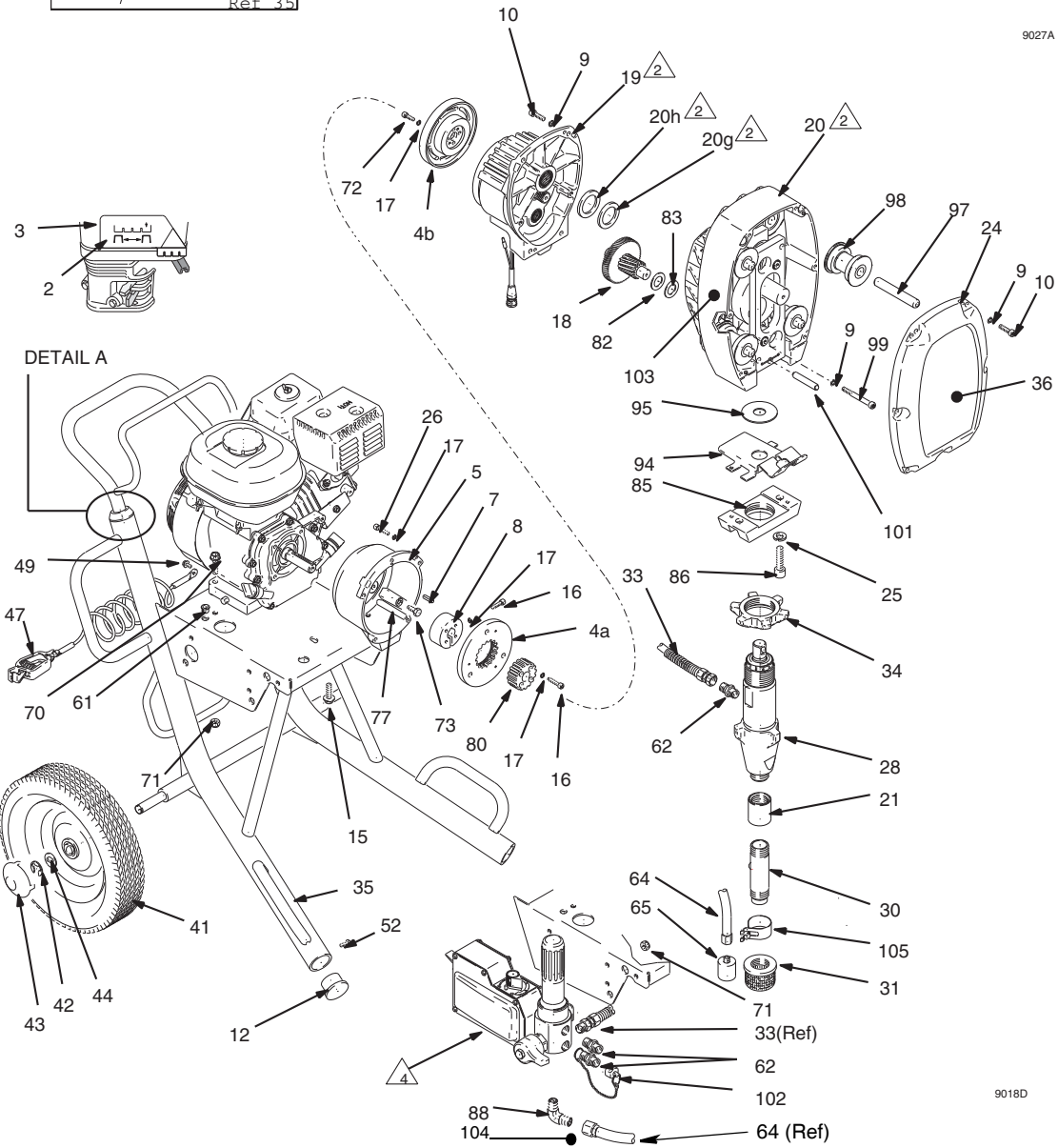

9018D

Parts List - Hi-Boy Sprayers

Models 232630, 232631 and 233008*

Ref	Part No.	Description	Qty
1	114530	ENGINE	1
2	113084	RIVET, blind	2
3	192014	PLATE, indicator	1
4	241113	CLUTCH, assembly, includes 4a, 4b, 15, 17, 72, 80	1
4a		ARMATURE, clutch, 5 inch	1
4b		ROTOR, 5 inch	1
5	193531	CLUTCH HOUSING	1
7	183401	KEY, parallel	1
8	193680	CLAMP	1
9	104008	WASHER, spring lock	12
10	101864	CAPSCREW, socket head, 1/4-20 x 3/4 in.	10
11	239998	CART HANDLE & HOSE RACK	1
12	193682	CAP, end	2
15	113802	SCREW, flange, hex hd, 3/8-16 x 5/8 in.	1
16	108803	CAPSCREW, sch, 1/4-2 x 1 in.	6
17	105510	LOCKWASHER, spring, 1/4 in.	15
18	241539	GEAR COMBINATION, include 91 and 92	1
19	241116	PINION ASSEMBLY; Parts page 24	1
20	241536	DRIVE HOUSING, Parts, page 24	1
21	114967	COUPLING	1
24	241537	COVER, housing, drive, kit	1
25	100018	WASHER, lock, spring	1
26	100644	SCREW, cap	5
28	240917	DISPLACEMENT PUMP, Parts manual 308798	1
29	194438	TUBE, nylon, split	1
30	244823	TUBE, intake, includes 21	1

Ref	Part No.	Description	Qty
31	189920	STRAINER	1
33	240795	HOSE, coupled	1
34	193394	NUT, retaining	1
35	241324	CART FRAME	1
36	194068	LABEL, identification	1
37	183350	WASHER, plain	2
38	110243	RING, retaining	2
39	108795	SCREW, mch, pn hd, 10-32 x 5/16 in.	4
40	191084	SLEEVE	2
41	179811	WHEEL, semi-pneumatic	2
42	101242	RING, retaining	2
43	104811	HUBCAP	2
44	154636	WASHER	2
45	112827	BUTTON, snap	2
47	237686	GROUNDING, CLAMP & WIRE	1
49	112798	SCREW, hex washer hd, No. 8 x 3/8 in.	1
52	114984	SCREW, mch, pn hd	2
56	194126	LABEL, warning	1
▲			
61	114678	BUSHING, strain relief	1
62	162485	NIPPLE, 3/8-18 npsm(m) x 3/8 npt(m)	3
64	194178	HOSE, drain	1
65	241718	DEFLECTOR	1
70	110837	SCREW, flng, hex hd, 5/16-18 x 1-1/2 in.	2
71	110838	LOCKNUT, heavy, hex hd, 5/16-18	6
72	101682	SCREW, cap sch	4
73	108842	SCREW, cap sch	4

Ref	Part No.	Description	Qty
77	100214	WASHER, lock spring	4
78	114687	CLIP, retainer	1
80		HUB, armature	1
82	114699	WASHER, thrust	1
83	114672	WASHER, thrust	1
85	194118	BRACKET, pump	1
86	110343	SCREW, cap, sch	2
87	240997	CONUDCTOR, ground	1
88	110249	ADAPTER, male elbow, 90°	1
93	108851	WASHER	2
94	241540	PAIL HOOK Repair Kit, includes 95	1
95	195377	GROMMET, pump	1
96	206994	THROAT SEAL LIQUID; not shown	1
97	114695	DOWEL PIN	4
98	241322	ROLLER, assembly	4
99	114693	SCREW, cap, sch	2
101	195523	PIN	1
102	240987	PLUG, packless 3/8 in.	1
103 ▲	194317	LABEL, warning	1
104 ▲	195119	LABEL, warning; not shown	1
105	194194	CLIP, spring	1

▲ Replacement Danger and Warning labels, tags and cards are available at no cost.

* Model 233008 includes Gauge Kit 241339.

Parts Drawing - Lo-Boy Sprayer

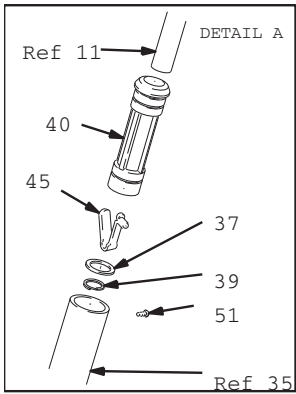

- 1 Label
- 2 See page 17 for the parts.
- 3 See manual 308798 for the parts.
- 4 See page 22 for the parts.

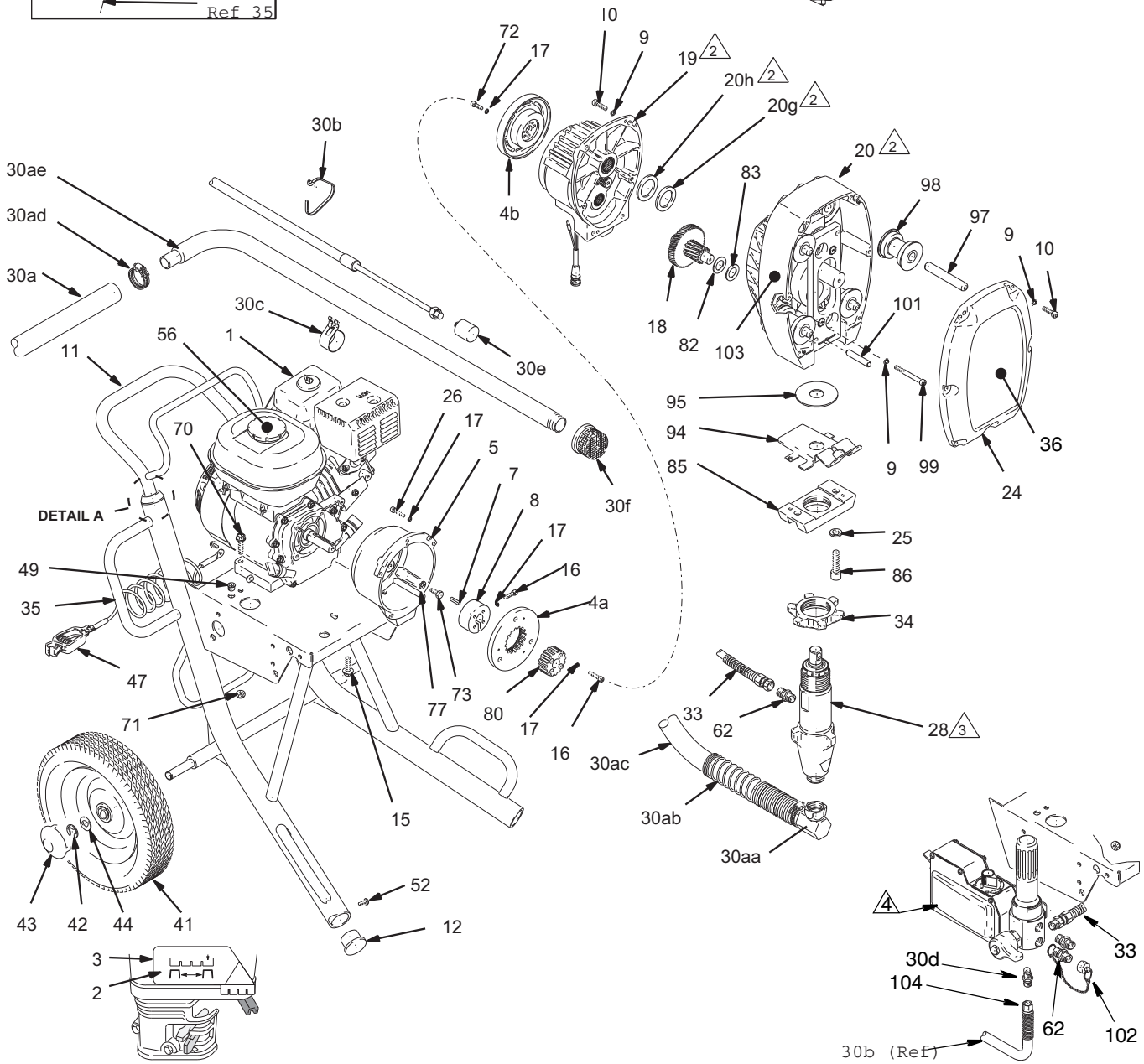
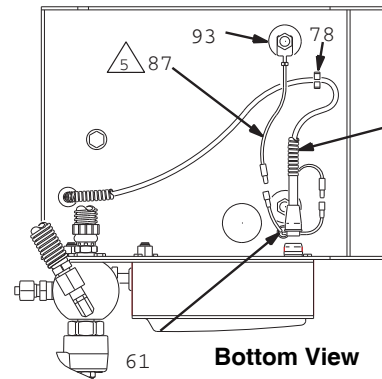

Parts List - Lo-Boy Sprayers

Models 232632, 232633

Ref	Part No.	Description	Qty
1	114530	ENGINE	1
2	113084	RIVET, blind	2
3	192014	PLATE, indicator	1
4	241113	CLUTCH, assembly, includes 4a, 4b, 15, 17, 72, 80	1
4a		ARMATURE, clutch, 5 inch	1
4b		ROTOR, 5 inch	1
5	193531	CLUTCH HOUSING	1
7	183401	KEY, parallel	1
8	193680	CLAMP	1
9	104008	WASHER, spring lock	12
10	101864	CAPSCREW, socket head, 1/4-20 x 3/4 in.	10
11	239998	CART HANDLE & HOSE RACK	1
12	193682	CAP, end	2
15	113802	SCREW, flange, hex hd, 3/8-16 x 5/8 in.	1
16	108803	CAPSCREW, sch, 1/4-2 x 1 in.	6
17	105510	LOCKWASHER, spring, 1/4 in.	15
18	241539	GEAR COMBINATION, include 91 and 92	1
19	241116	PINION ASSEMBLY; Parts page 24	1
20	241536	DRIVE HOUSING, Parts, page 24	1
24	241536	COVER, housing, drive, kit	1
25	100018	WASHER, lock, spring	1
26	100644	SCREW, cap	5
28	240917	DISPLACEMENT PUMP, Parts manual 308798	1
29	194438	TUBE, nylon, split	1

Ref	Part No.	Description	Qty
30	241288	ASSEMBLY, tube suction	1
30a	241269	. TUBE, suction, 30 gallon (120 L) included 30aa - 3ae	1
30aa	198119	.. SWIVEL, tube inlet	1
30ab	176450	.. GUARD, hose	1
30ac	194307	.. HOSE, fluid	1
30ad	101818	.. CLAMP, hose	2
30ae	192633	.. TUBE, suction	1
30b	194180	. HOSE, drain	1
30c	194194	. CLIP, spring	1
30d	162453	. NIPPLE	1
30e	241718	. DEFLECTOR	1
30f	189920	. STRAINER	1
33	240795	HOSE, coupled	1
34	193394	NUT, retaining	1
35	241324	CART FRAME	1
36	194068	LABEL, identification	1
37	183350	WASHER, plain	2
38	110243	RING, retaining	2
39	108795	SCREW, mch, pn hd, 10-32 x 5/16 in.	4
40	191043	SLEEVE	2
41	179811	WHEEL, semi-pneumatic	2
42	101242	RING, retaining	2
43	104811	HUBCAP	2
44	154636	WASHER	2
45	112827	BUTTON, snap	2
47	237686	GROUNDING, CLAMP & WIRE	1
49	112798	SCREW, hex washer hd, No. 8 x 3/8 in.	1
52	114984	SCREW, mch, pn hd	2
56▲	194126	LABEL, warning	1
61	114678	BUSHING, strain relief	1

Parts List - Lo-Boy Sprayers

Ref	Part No.	Description	Qty
62	162485	NIPPLE, 3/8-18 npsm(m) x 3/8 npt(m)	3
64	194178	HOSE, drain	1
65	241718	DEFLECTOR	1
70	110837	SCREW, flng, hex hd, 5/16-18 x 1-1/2 in.	2
71	110838	LOCKNUT, heavy, hex hd, 5/16-18	6
72	101682	SCREW, cap sch	4
73	108842	SCREW, cap sch	4
77	100214	WASHER, lock spring	4
78	114687	CLIP, retainer	1
80		HUB, armature	1
82	114699	WASHER, thrust	1
83	114672	WASHER, thrust	1
85	194118	BRACKET, pump	1
86	110343	SCREW, cap, sch	2
87	240997	CONUDCTOR, ground	1
88	110249	ADAPTER, male elbow, 90°	1
93	108851	WASHER	2
94	241540	PAIL HOOK Repair Kit, includes 95	1
95	194681	GROMMET, pump	1
96	206994	THROAT SEAL LIQUID; not shown	1
97	114695	DOWEL PIN	4
98	241322	ROLLER, assembly	4
99	114693	SCREW, cap, sch	2
101	195523	PIN	1
102	240987	PLUG, packless 3/8 in.	1
103 ▲	194317	LABEL, warning	1
104 ▲	195119	LABEL, warning; not shown	1

▲ Replacement Danger and Warning labels, tags and cards are available at no cost.

Model 232630 through 232633

Models 232630 through 232633

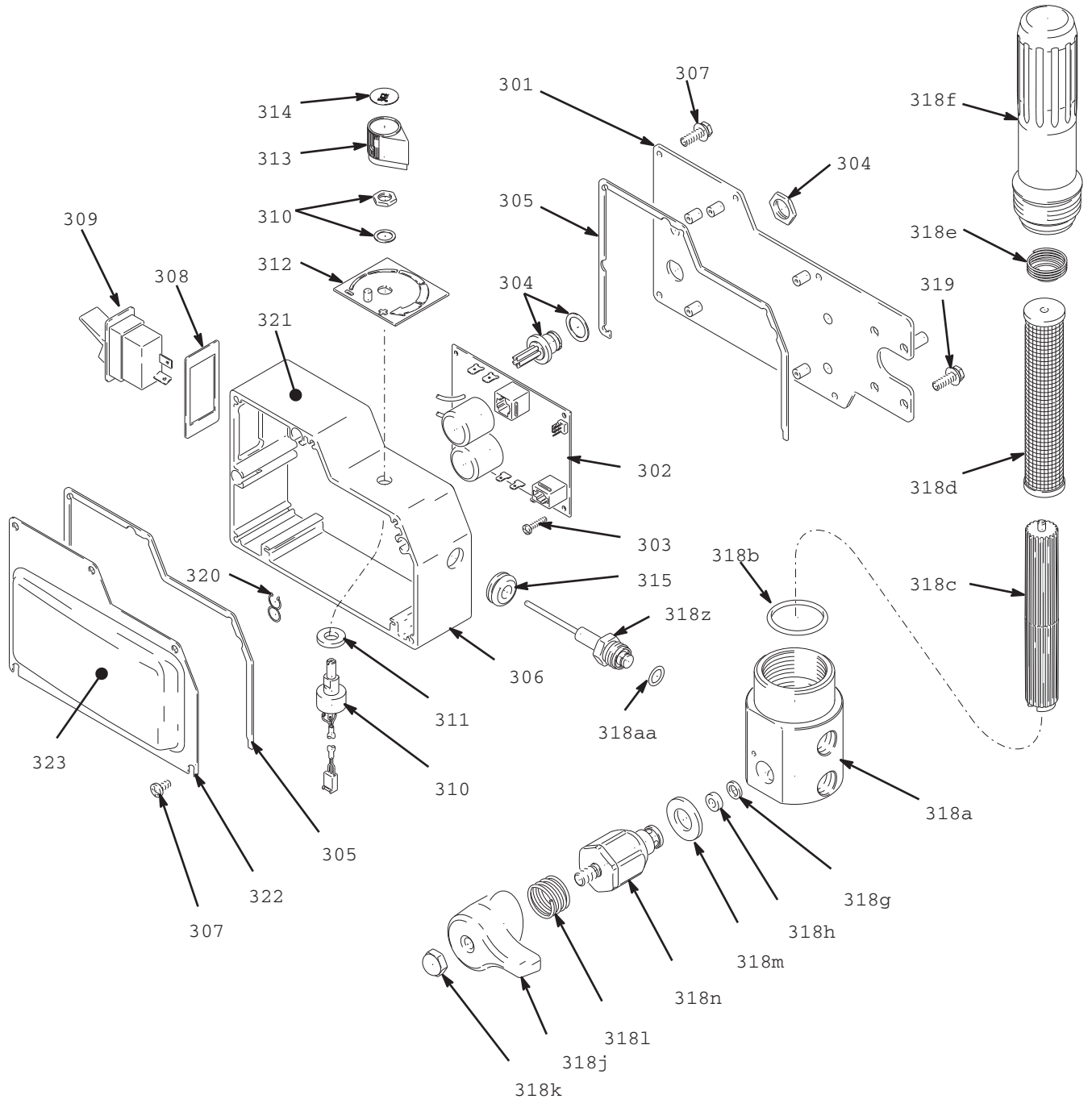

8716A

Parts List - Hi-Boy Sprayers

Models 232630 through 232633

Ref	Part No.	Description	Qty
301	193653	PLATE, control	1
302	241093	BOARD, PC	1
303	111839	SCREW, mch pan, 6-32 x 1/2 in.	5
304	240776	HARNESS, wiring	1
305	193497	GASKET, control	2
306	193652	HOUSING, control box	1
307	114631	SCREW, mach, pan hd	10
308	193052	PLATE, instruction	1
309	114277	SWITCH, rocker (spst)	1
310	241443	POTENTIOMETER, pressure control	1
311	193657	GASKET, potentiometer	1
312	193654	PLATE, instruction	1
313	114273	KNOB, potentiometer	1
314	193072	LABEL, control	1
315	114629	GROMMET, transducer	1
318		FILTER, fluid	1
318a	193651	HOUSING, filter	1
318b	104361	O-RING	1
318c	186075	SUPPORT, filter	1
318d	167025	STRAINER, mesh, 60	1
318e	171941	SPRING, compression	1
318f	192706	BOWL, filter	1
318g	193710	SEAL, valve	1
318h	193709	SEAT, valve	1
318j	194102	HANDLE, valve	1
319k	114688	NUT, cap, hex hd	1
319l	114708	SPRING, compression	1
319m	114797	GASKET	1
318n	245103*	VALVE	1

Ref	Part No.	Description	Qty
318z	240314	TRANSDUCER, pressure control includes 318aa	1
318aa	111457	O-RING	1
319	110997	SCREW, flange, hex	3
320	114532	TIE, wire, twist	1
321▲	189246	LABEL, warning	1
322	241444	COVER, pressure control	1
323	193684	LABEL, identification	1

▲ Replacement Danger and Warning labels, tags and cards are available at no cost.

* Drain valve replacement kit 245103 included 318g through 318n.

Parts List - Complete Sprayers

Models 232631, 232633

Includes 201 to 204

Ref.	Part No.	Description	Qty
201	232631	Hi-Boy Sprayer, see Parts list on page 26	1
	232633	Lo-Boy Sprayer, See Parts list on page 32	1
202	240797	HOSE, grounded, nylon, 3/8 in. ID; cpld 3/8 npsm(fbe); 50 foot (15 m); spring guards both ends	1
203	238358	HOSE, grounded, nylon; 3/16. ID; cpld 1/4 npsm(m) x 1/4 npsm(f) swivel; 3 foot (0.9 m); spring guards both ends	1
204	220955	CONTRACTOR SPRY GUN, includes RAC 5™ DripLess Tip Guard and 517-size SwitchTip™, see 309091 for parts	1

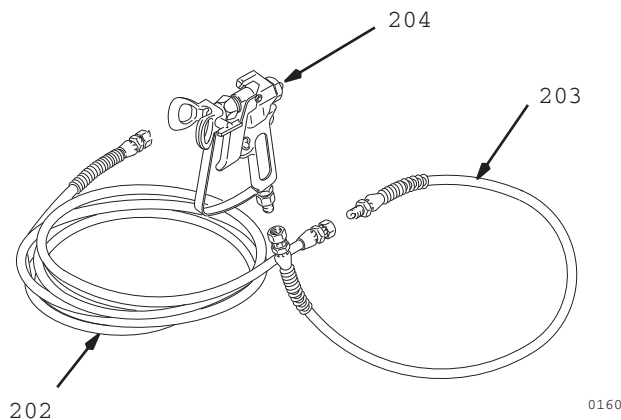

Accessories

Danger Labels

An English language DANGER label is on your sprayer. If you have painters who do not read English, order one of the following labels to apply to your sprayer. The drawing shows the best placement of these labels for good visibility.

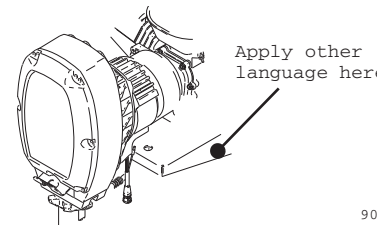

Order the labels from your Graco distributor.

Language	Part No.
French	194931
Spanish	194932
German	194933
Greek	194934
Korean	194935
English	194317

Displacement Pump Repair Kit

Packing repair kit. - GMax 7900: 240916

Wiring Diagram

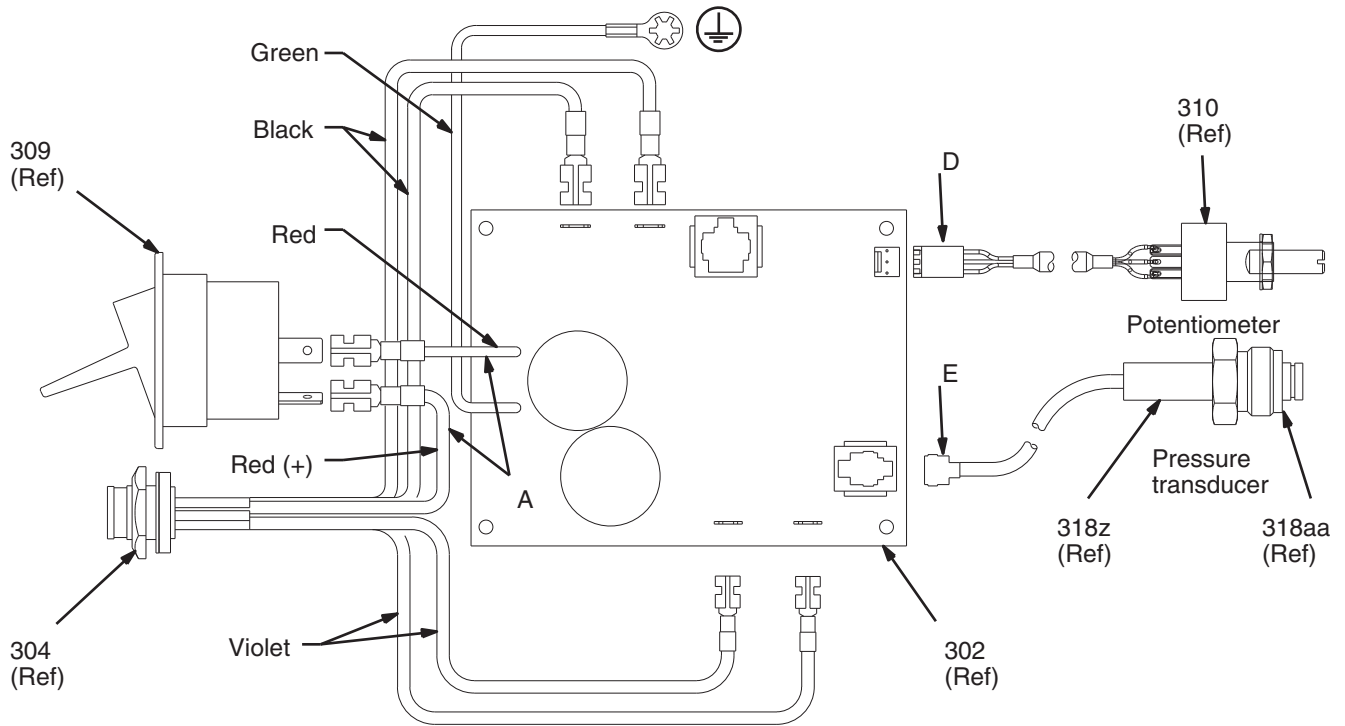

Technical Data

Honda GX160 Engine	
Power Rating @ 3700 RPM	
ANSI	5.5 horsepower
DIN 6270B/DIN 6271	
NA	2.9 Kw - 4.0 Ps
NB	3.6 Kw - 4.9 Ps
Maximum working pressure	3300 psi (227 bar, 22.7 MPa)
Noise Level	
Sound power	105 dBa per ISO 3744
Sound pressure	96 dBa measured at 3.1 feet (1 m)
Cycle/gallon (liter)	69 (18)
Maximum delivery rating	2.1 gpm (7.9 liter/min)
Maximum tip size	1 gun with 0.046 in. tip
	2 guns with 0.033 in. tip
	3 gun with 0.026 in. tip
	4 guns with 0.022 in. tip
Inlet pain strainer	16 mesh (1190 micron) stainless steel screen, reusable
Outlet paint filter	60 mesh (250 micron) stainless steel screen, reusable
Pump inlets size	3/4 in. npt(m)
Fluid outlet size	1/4 npsm from fluid filter
Wetted parts	zinc-plated carbon steel, PTFE, Nylon, polyurethane, UHMW polyethylene, FKM, acetal, leather, aluminum, tungsten, carbide, nickel-plated carbon steel, stainless steel, chrome plating

Dimensions

Model 232630, 232631, 232008

Hi-Boy without hose or gun

Weight (dry without packaging)	175 lb (79.4 kg)
Height	41 in. (104.1 cm)
Length	38 in. (96.5 cm)
Width	22 in. (55.9 cm)

Model 232632, 232633

Lo-Boy Cart without hose or gun

Weight (dry without packaging)	180 lb (82.1 kg)
Height	41 in. (104.1 cm)
Length	38 in. (96.5 cm)
Width	22 in. (55.9 cm)

Graco Warranty

Graco warrants all equipment manufactured by Graco and bearing its name to be free from defects in material and workmanship on the date of sale by an authorized Graco distributor to the original purchaser for use. With the exception of any special, extended, or limited warranty published by Graco, Graco will, for a period of twelve months from the date of sale, repair or replace any part of the equipment determined by Graco to be defective. This warranty applies only when the equipment is installed, operated and maintained in accordance with Graco's written recommendations.

This warranty does not cover, and Graco shall not be liable for general wear and tear, or any malfunction, damage or wear caused by faulty installation, misapplication, abrasion, corrosion, inadequate or improper maintenance, negligence, accident, tampering, or substitution of non-Graco component parts. Nor shall Graco be liable for malfunction, damage or wear caused by the incompatibility of Graco equipment with structures, accessories, equipment or materials not supplied by Graco, or the improper design, manufacture, installation, operation or maintenance of structures, accessories, equipment or materials not supplied by Graco.

This warranty is conditioned upon the prepaid return of the equipment claimed to be defective to an authorized Graco distributor for verification of the claimed defect. If the claimed defect is verified, Graco will repair or replace free of charge any defective parts. The equipment will be returned to the original purchaser transportation prepaid. If inspection of the equipment does not disclose any defect in material or workmanship, repairs will be made at a reasonable charge, which charges may include the costs of parts, labor, and transportation.

THIS WARRANTY IS EXCLUSIVE, AND IS IN LIEU OF ANY OTHER WARRANTIES, EXPRESS OR IMPLIED, INCLUDING BUT NOT LIMITED TO WARRANTY OF MERCHANTABILITY OR WARRANTY OF FITNESS FOR A PARTICULAR PURPOSE.

Graco's sole obligation and buyer's sole remedy for any breach of warranty shall be as set forth above. The buyer agrees that no other remedy (including, but not limited to, incidental or consequential damages for lost profits, lost sales, injury to person or property, or any other incidental or consequential loss) shall be available. Any action for breach of warranty must be brought within two (2) years of the date of sale.

Graco makes no warranty, and disclaims all implied warranties of merchantability and fitness for a particular purpose in connection with accessories, equipment, materials or components sold but not manufactured by Graco. These items sold, but not manufactured by Graco (such as electric motors, switches, hose, etc.), are subject to the warranty, if any, of their manufacturer. Graco will provide purchaser with reasonable assistance in making any claim for breach of these warranties.

In no event will Graco be liable for indirect, incidental, special or consequential damages resulting from Graco supplying equipment hereunder, or the furnishing, performance, or use of any products or other goods sold hereto, whether due to a breach of contract, breach of warranty, the negligence of Graco, or otherwise.

FOR GRACO CANADA CUSTOMERS

The parties acknowledge that they have required that the present document, as well as all documents, notices and legal proceedings entered into, given or instituted pursuant hereto or relating directly or indirectly hereto, be drawn up in English. Les parties reconnaissent avoir convenu que la rédaction du présente document sera en Anglais, ainsi que tous documents, avis et procédures judiciaires exécutés, donnés ou intentés à la suite de ou en rapport, directement ou indirectement, avec les procédures concernées.

ADDITIONAL WARRANTY COVERAGE

Graco does provide extended warranty and wear warranty for products described in the "Graco Contractor Equipment Warranty Program".

Graco Phone Number

TO PLACE AN ORDER, contact your Graco distributor, or call this number to identify the distributor closest to you: 1-800-690-2894 Toll Free

*All written and visual data contained in this document reflects the latest product information available at the time of publication.
Graco reserves the right to make changes at any time without notice.*

Original instructions. This manual contains English. MM 308870
For Patent Information see www.graco.com/patents

Graco Headquarters: Minneapolis
International Offices: Belgium, China, Japan, Korea

GRACO INC. AND SUBSIDIARIES • P.O. BOX 1441 • MINNEAPOLIS MN 55440-1441 • USA

Copyright 1999, Graco Inc. All Graco manufacturing locations are registered to ISO 9001.

www.graco.com
Revised April 2014