

OPERATION – TOEPASSING FONCTIONNEMENT – BETRIEB



308853

Rev. D

ULTRA® MAX 695

3000 psi (210 bar, 21 MPa) Maximum Working Pressure

Maximum werkdruk 3000 psi (210 bar, 21 MPa)

Pression de service maximum 3000 psi (210 bar, 21 MPa)

Zulässiger Betriebsüberdruck 3000 psi (210 bar, 21 MPa)

232138, 230V

232134 and 232135, 240V

232136 and 232137, 100V

232139, 120V

All models not available in all countries

Niet alle modellen zijn in alle landen beschikbaar

Tous les modèles ne sont pas disponibles dans tous les pays

Nicht alle Modelle sind in allen Ländern verfügbar

Related manuals

Bijbehorende handleidingen

Autres manuels techniques

Verwandte Formblätter



..... 308852



..... 307614

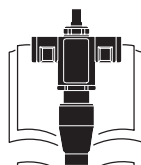

..... 308815



..... 308644

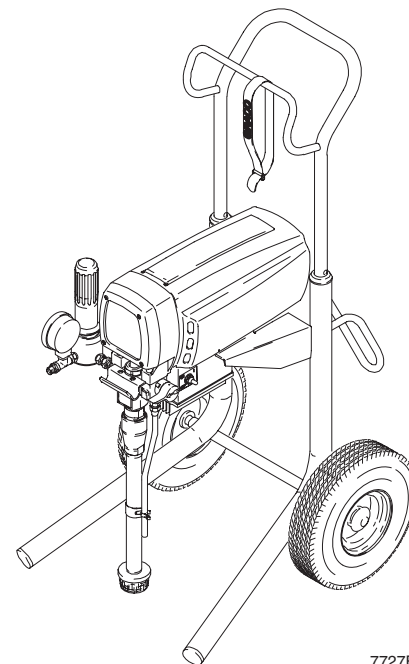

7727B

232138

INSTRUCTIONS	INSTRUCTIES
<p>READ ALL INSTRUCTION AND WARNINGS BEFORE SETTING UP OR OPERATING THIS UNIT.</p>	<p>LEES ALLE INSTRUCTIES EN WAARSCHUWINGEN VOORDAT U DE APPARATUUR INSTALLEERT OF TOEPAST</p>
<p>You need:</p> <ul style="list-style-type: none"> two adjustable wrenches two 5 gallon (19 liters) metal pails Compatible cleaning fluids 	<p>Benodigd:</p> <ul style="list-style-type: none"> twee verstelbare sleutels twee 20 liter metalen vaten Geschikte reinigingsvloeistoffen
<p>Power: grounded outlet</p> <p>Japan: 100V, 15A</p> <p>United Kingdom: 110V, 15A</p> <p>North/Latin Am: 120V, 15A</p> <p>Europe/South Am: 230V, 10A</p> <p>Australia/Asia: 240V, 10A</p> <ul style="list-style-type: none"> 12 AWG, (1.5 mm²) grounded extension cord up to 300 feet (100 M) 	<p>Elektrische voeding: geaard stopcontact</p> <p>Japan: 100V, 15A</p> <p>United Kingdom: 110V, 15A</p> <p>North/Latin Am: 120V, 15A</p> <p>Europe/South Am: 230V, 10A</p> <p>Australia/Asia: 240V, 10A</p> <ul style="list-style-type: none"> 12 AWG, (1.5 mm²) geaard verlengsnoer van maximaal 300 voet (100 meter)
<p>Clothing:</p> <ul style="list-style-type: none"> respirator safety glasses 	<p>Kleding:</p> <ul style="list-style-type: none"> ademhalingsfilter veiligheidsbril
<p>INSTRUCTIONS</p>	<p>ANLEITUNG</p>
<p>LIRE TOUTES LES INSTRUCTIONS ET MISES EN GARDE AVANT L'INSTALLATION OU LA MISE EN MARCHÉ DE CET APPAREIL.</p>	<p>VOR DEM EINRICHTEN ODER DER INBETRIEBNAHME DIESES GERÄTES ALLE BEDIENUNGSANLEITUNGEN UND SICHERHEITSHINWEISE LESEN.</p>
<p>Il vous faut:</p> <ul style="list-style-type: none"> deux clés à molette deux seaux métalliques de 20 litres des produits de nettoyage compatibles 	<p>Erforderlich:</p> <ul style="list-style-type: none"> zwei einstellbare Schlüssel zwei 20 l Metalleimer verträgliche Reinigungsflüssigkeit
<p>Alimentation électrique: Prise de</p> <p>Japan: 100V, 15A</p> <p>United Kingdom: 110V, 15A</p> <p>North/Latin Am: 120V, 15A</p> <p>Europe/South Am: 230V, 10A</p> <p>Australia/Asia: 240V, 10A</p> <ul style="list-style-type: none"> câble de 12 AWG, (1,5 mm²) de 100 m maximum mis à la terre 	<p>Spannung: geerdeter Stecker mit</p> <p>Japan: 100V, 15A</p> <p>United Kingdom: 110V, 15A</p> <p>North/Latin Am: 120V, 15A</p> <p>Europe/South Am: 230V, 10A</p> <p>Australia/Asia: 240V, 10A</p> <ul style="list-style-type: none"> geerdetes Verlängerungskabel mit 12 AWG (1,5 mm²) bis zu 100 m lang
<p>Habillement:</p> <ul style="list-style-type: none"> respirateur lunettes de sûreté 	<p>Kleidung:</p> <ul style="list-style-type: none"> Atemmaske Schutzbrillen

GRACO INC. P.O. BOX 1441 MINNEAPOLIS, MN 55440-1441

Graco Inc. is registered to I.S. EN ISO 9001

! WARNING

Fire and explosion can occur when spraying or flushing flammable fluid in an area where air circulation is poor and flammable vapors can be ignited by an open flame or sparks.

To help prevent a fire and explosion:

- **Use outdoors or in an extremely well ventilated area.**
- Do not use 1,1,1-trichloroethane, methylene chloride, other halogenated hydrocarbon solvents or fluids containing such solvents in pressurized aluminum equipment. Such use could result in a chemical reaction, with the possibility of explosion.
- Remove, extinguish or unplug all ignition sources; tape wall switches. Do not smoke in spray area.
- Ground Sprayer, object being sprayed, paint and solvent pails.
- Hold gun firmly to side of a grounded pail when triggering into pail.
- Use a properly grounded outlet.
- Use only conductive airless paint hose.



Fluid injection is a serious injury! If high pressure fluid pierces your skin, the injury might look like "just a cut". But it is a serious wound! Get immediate medical attention.

To help prevent injection, always:

- Engage trigger safety latch when not spraying.
- Point gun away from yourself or anyone else.
- Relieve pressure before checking or repairing any leak.
- Relieve pressure when you turn off the sprayer or stop spraying
- Do not use components rated less than system *Maximum Working Pressure*

Never allow children to use this unit. If you are injured using this equipment, get immediate medical treatment.



! WAARSCHUWING

Brand en ontploffing kunnen het gevolg zijn van spuiten of spoelen met ontvlambare vloeistof bij onvoldoende luchtcirculatie. Brandbare dampen kunnen dan tot onsteking komen door open vlammen of vonken.

Voorkom brand en explosies door de volgende maatregelen:

- **Alleen buitenshuis of in een zeer goed geventileerde ruimte gebruiken.**
- Gebruik in van aluminium vervaardigde apparatuur die onder druk staat geen 1,1,1-trichloorethaan, methyleenchloride, andere halogeenkoolwaterstoffen of materialen die zulke oplosmiddelen bevatten. Het gebruik van zulke stoffen kan namelijk een chemische reactie geven, met kans op ontploffing.
- Verwijder of doof alle ontstekingsbronnen, haal stekkers los, plak muurschakelaars af. Rook niet in de spuitruimte.
- Aard de spuitapparatuur, het te spuiten voorwerp, en vaten met verf en oplosmiddel.
- Houd het pistool stevig tegen de zijkant van een geaard vat gedrukt bij het spuiten in het vat.
- Gebruik een goed geaard stopcontact.
- Gebruik alleen een geaarde verflang voor luchtloos spuiten.

Vloeistofinjectie is een zware verwonding! Als vloeistof onder hoge druk door de huid heen binnendringt kan het op een gewone snijwond lijken. Maar het is een ernstige wond! Roep meteen medische hulp in.

Houd altijd deze regels aan om vloeistofinjectie te voorkomen:

- Gebruik de veiligheidsvergrendeling van de trekker als er niet gespoten wordt.
- Richt het pistool nooit op uzelf of op anderen.

- Ontlast de druk vóór controle of reparatie van lekken.
- Ontlast de druk bij uitschakelen en als u stopt met spuiten.

Laat nooit kinderen deze apparatuur gebruiken. Roep bij verwondingen door gebruik van de apparatuur meteen medische hulp in.

! MISE EN GARDE

Un incendie et une explosion peuvent se produire en cas de pulvérisation ou de rinçage avec un produit inflammable dans un local mal ventilé et où les vapeurs inflammables peuvent prendre feu au contact d'une flamme ou d'une étincelle.

Comment éviter un incendie et une explosion:

- **A utiliser à l'air libre ou dans un local très bien aéré.**
- Ne pas utiliser de trichloréthane 1,1,1, de chlorure de méthylène, d'autres solvants à base d'hydrocarbures halogénés ni de produits contenant de tels solvants dans un équipement en aluminium sous pression. Il pourrait en résulter une réaction chimique pouvant provoquer une explosion.
- Enlever, éteindre ou débrancher toutes les sources de feu. Coller du ruban adhésif sur les interrupteurs muraux. Ne pas fumer dans la zone de pulvérisation.
- Mettre le pulvérisateur, l'objet à peindre, la peinture et les seaux de solvant à la terre.
- Appuyer fortement le pistolet contre le bord d'un seau mis à la terre au moment de pulvériser dans le seau.
- Utiliser une prise correctement reliée à la terre.
- Utiliser uniquement un flexible de peinture sans air conducteur.

Une injection de produit est une blessure grave! Du produit injecté à haute pression sous la peau peut présenter l'aspect d'une "simple coupure", mais il s'agit d'une blessure grave qui exige des soins médicaux immédiats.

Comment éviter une injection. Toujours:

- Verrouiller la gâchette quand la pulvérisation est arrêtée.
- Détourner le pistolet de soi-même ou d'une autre personne.
- Décompresser avant de contrôler ou de réparer une fuite.
- Décompresser lors de la mise à l'arrêt du pulvérisateur ou d'une interruption de la pulvérisation.

Ne jamais laisser les enfants se servir de cet appareil. En cas de blessure avec ce matériel, faire appel à un médecin.



! WARNING

Brand- und Explosionsgefahr besteht beim Spritzen oder Spülen von brennbaren Flüssigkeiten in einem Bereich, wo nur schwache Luftzirkulation vorhanden ist und brennbare Dämpfe durch offene Flammen oder Funken entzündet werden könnten.

Durch folgende Punkte kann die Brand- und Explosionsgefahr verringert werden:

- **Gerät nur im Freien oder in sehr gut belüfteten Räumen verwenden.**
- Niemals 1,1,1-Trichlorethan, Methylenchlorid, andere Lösemittel mit halogenisierten Kohlenwasserstoffen oder Materialien, die solche Lösemittel enthalten, in druckbeaufschlagten Aluminiumgeräten verwenden. Dies könnte zu einer chemischen Reaktion führen und in der Folge eine Explosion verursachen.
- Alle potentiellen Zündquellen vermeiden; Wandschalter mit Klebeband abdichten. Im Spritzbereich nicht rauchen.
- Spritzgerät, Spritzobjekt sowie Material- und Lösemittelleimer erden.
- Beim Spritzen in einen geerdeten Eimer die Pistole fest an den Eimer drücken.
- Eine richtig geerdete Steckdose verwenden.
- Nur einen elektrisch leitfähigen Airless-Materialschlauch verwenden.

Eine Materialeinspritzung ist eine schwere Verletzung! Wenn Material mit hohem Druck in die Haut eindringt, kann die dabei entstehende Wunde wie ein "einfacher Schnitt" aussehen. Tatsächlich ist es jedoch eine schwere Verletzung! In diesem Fall sofort einen Arzt aufsuchen.

Um Einspritzungen zu vermeiden, stets:

- Die Abzugssperre an der Pistole verriegeln, wenn nicht gespritzt wird.
- Pistole niemals gegen den eigenen Körper oder andere Personen richten.
- Vor Überprüfungs- oder Reparaturarbeiten immer den Druck entlasten.
- Beim Abschalten des Spritzgerätes oder bei Einstellung der Spritzarbeiten den Druck entlasten.

Niemals Kinder an dieses Gerät lassen. Wenn Sie bei Verwendung dieses Gerätes verletzt werden, muß sofort ärztliche Hilfe geholt werden.

CONTROLS / BEDIENINGSORGANEN / COMMANDES / REGLER

Pressure Control Drukregeling Régulation de pression Druckregler

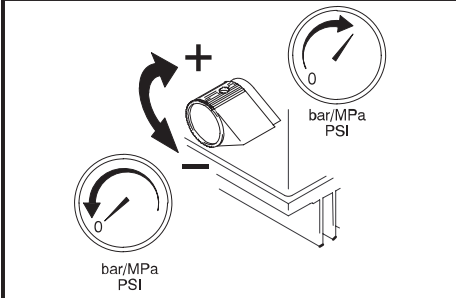

On/Off Switch Aan/Uit Schakelaar Interrupteur Marche/Arrêt Ein-Aus-Schalter

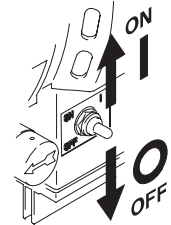

Drain Valve Aftapkraan Vanne de décharge Druckentlastungshahn

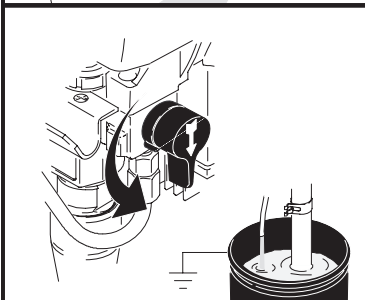
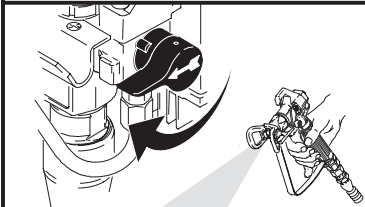

Trigger Lock Trekkervergrendeling Verrouillage de la gâchette Abzugssperre

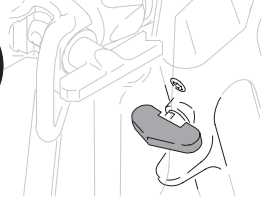

PRESSURE RELIEF / ONTLASTEN VAN DE DRUK / DÉCOMPRESSION / DRUCKENTLASTUNG



Follow 1-5 when you stop spraying.



Volg 1-5 wanneer u ophoudt met spuiten.

Suivre les opérations 1 à 5 pour arrêter la pulvérisation.

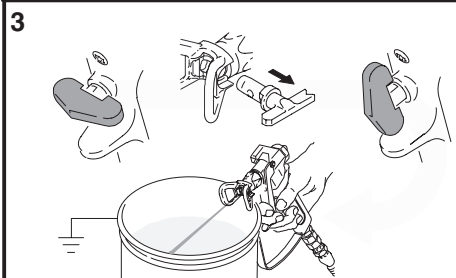
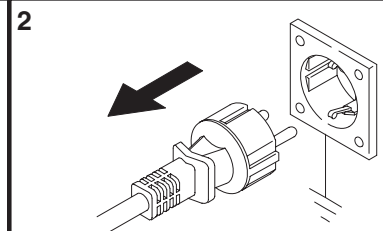
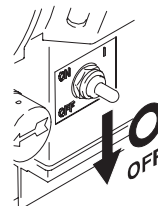
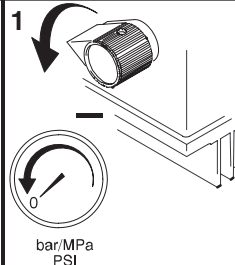

Schritte 1-5ausführen, wenn die Spritzarbeiten beendet werden.



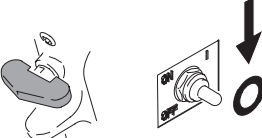
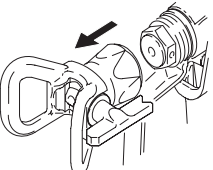
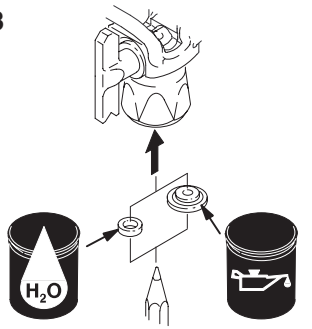

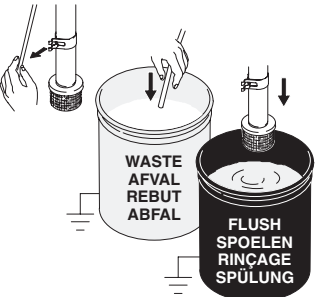
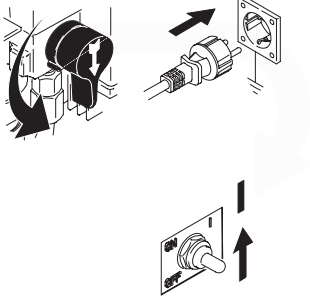
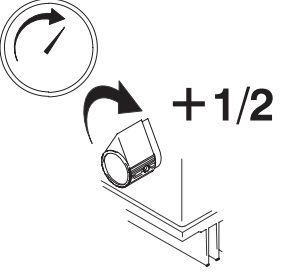
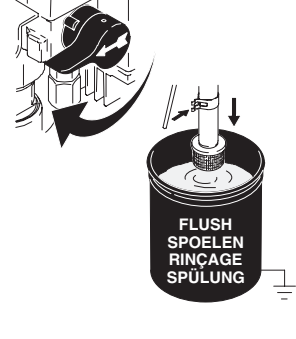

STARTUP / OPSTARTEN / MISE EN SERVICE / INBETRIEBNAHME

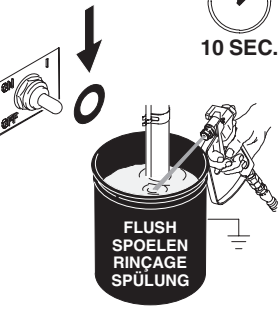
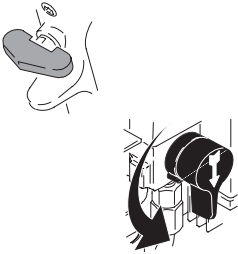
<p>Flush with warm soapy water. Spoel met warm zeepwater. Rincer à l'eau chaude et savonneuse. Mit warmem Seifenwasser spülen.</p>  <p>Flush with mineral spirits. Spoel met thinner Rincer au white spirit. Mit Lösungsbenzin spülen.</p> 	<p>1</p> <p>WARNING WAARSCHWING MISE EN GARDE WARNUNG</p>  	<p>2</p> 	<p>3</p> 
---	--	--	---

Flush / Spoelen / Rinçage / Spülung 4→11

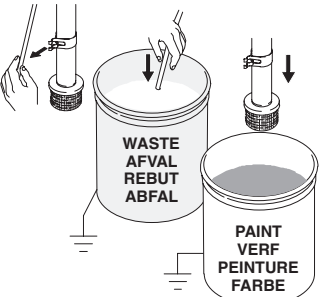
<p>4</p> <p>WARNING WAARSCHWING MISE EN GARDE WARNUNG</p>  	<p>5</p> 	<p>6</p> 	<p>7</p> 
<p>8</p>  <p>20 SEC.</p>	<p>9</p>  <p>1 MIN.</p>	<p>10</p>  <p>10 SEC.</p>	<p>11</p> 

Prime / Vullen / Amorçage / Entlüften 12→15

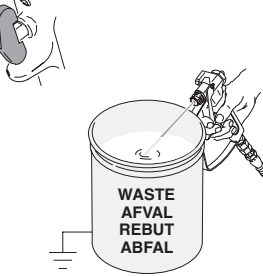
<p>12</p> <p>WARNING WAARSCHWING MISE EN GARDE WARNUNG</p>  	<p>13</p>   <p>Watch for paint. Wacht tot verf verschijnt. Attention à la peinture. Auf Spritzmaterial achten.</p>	<p>14</p>  	<p>15</p>  <p>Watch for paint. Wacht tot verf verschijnt. Attention à la peinture. Auf Spritzmaterial achten.</p>
--	---	---	---

SPRAY / SPUITEN / PULVÉRISATION / SPRITZEN

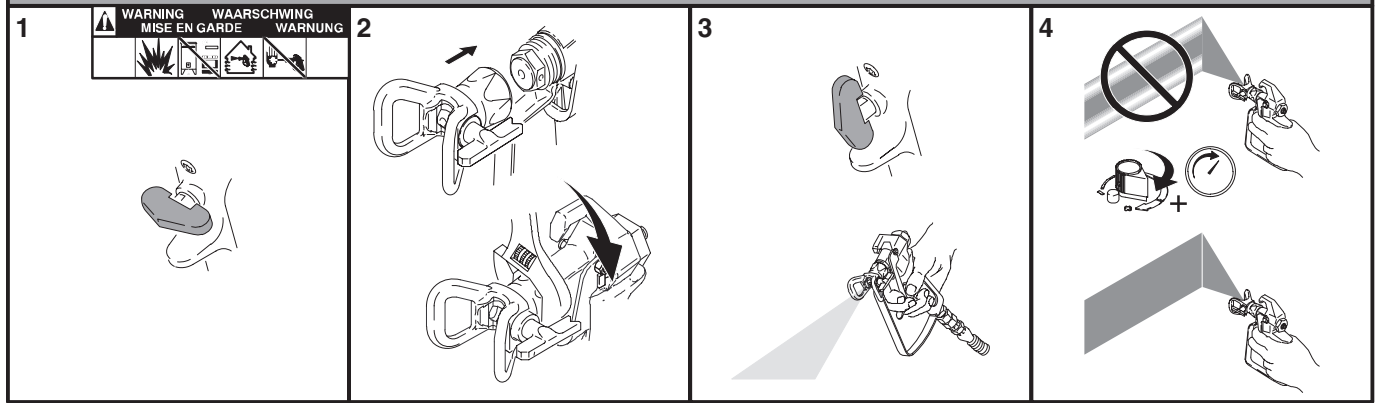

CLEAR CLOG / VERSTOPPING VERWIJDEREN / DÉBOUCHAGE / VERSTOPFUNG BESEITIGEN

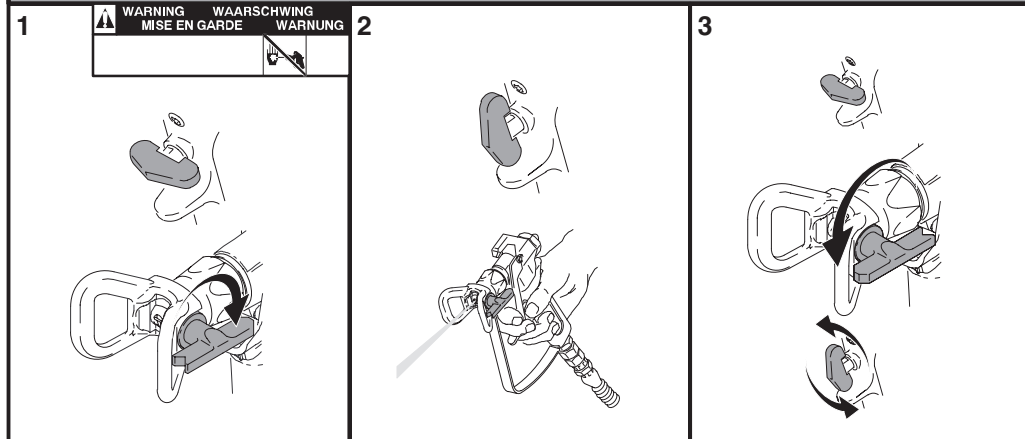

CHANGE PAINT / WISSELEN VAN VERF / CHANGEMENT DE PEINTURE / FARBE WECHSELN

<p>1</p> <p>Flush</p> <p>Spoelen</p> <p>Rinçage</p> <p>Spülung</p>	<p>2</p> <p>Prime</p> <p>Vullen</p> <p>Amorçage</p> <p>Entlüften</p>
---	---

SHUTDOWN / AFZETTEN / ARRÊT / GERÄT ABSCHALTEN

1



Pressure Relief
Drukontlasting
Décompression
Druckentlastung

2

WARNING WAARSCHUWING
 MISE EN GARDE WARNUNG

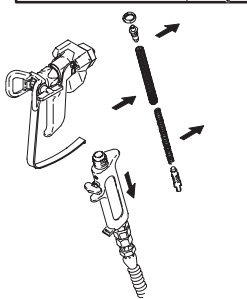

3

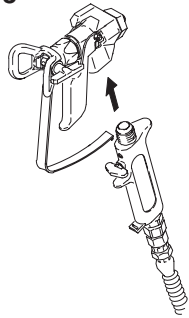

4

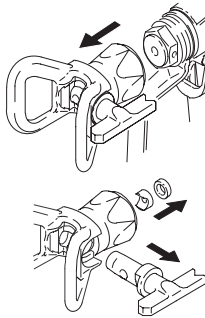

5

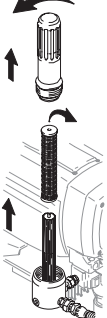

6

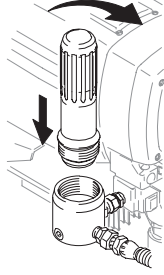

7

Flush
Spoelen
Rinçage
Spülung

8

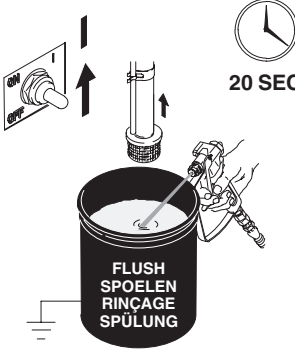

20 SEC.

FLUSH
 SPOELEN
 RINÇAGE
 SPÜLUNG

9



Pressure Relief
Drukontlasting
Décompression
Druckentlastung

10



FLUSH
 SPOELEN
 RINÇAGE
 SPÜLUNG

11

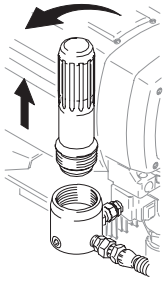

12

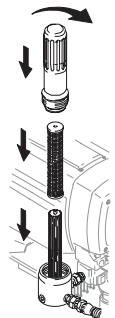

13

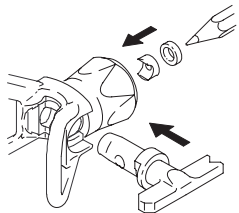

14

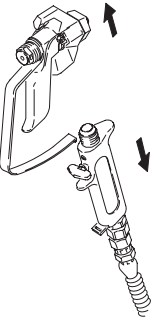

15

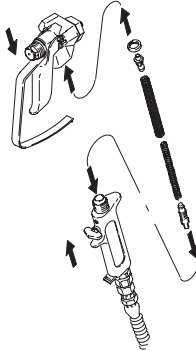

16

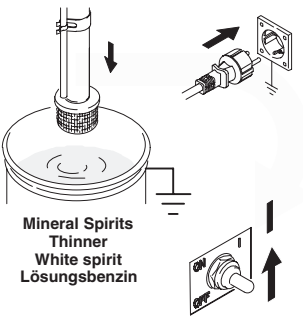

Mineral Spirits
 Thinner
 White spirit
 Lösungsbenzin

20 SEC.

17



WASTE
 AFVAL
 REBUT
 ABFAL

20 SEC.

18



Pressure Relief
Drukontlasting
Décompression
Druckentlastung

19



Mineral Spirits
 Thinner
 White spirit
 Lösungsbenzin

20

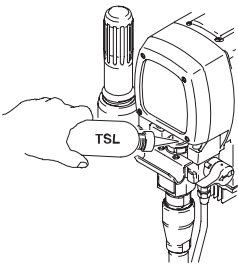

21

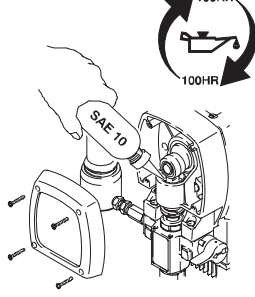

100HR

100HR

SAE 10

Noise Bruit Lärm Lawaai

Power Puissance Leistung Vermogen . . . 100 dB(A)*

Pressure Pression Druck Druk 90 dB(A)*

* ISO 3744

Graco Standard Warranty Standaard Graco Garantie Garantie standard de Graco Graco Standard-Garantie

Graco warrants all equipment referenced in this document which is manufactured by Graco and bearing its name to be free from defects in material and workmanship on the date of sale by an authorized Graco distributor to the original purchaser for use. With the exception of any special, extended, or limited warranty published by Graco, Graco will, for a period of twelve months from the date of sale, repair or replace any part of the equipment determined by Graco to be defective. This warranty applies only when the equipment is installed, operated and maintained in accordance with Graco's written recommendations.

This warranty does not cover, and Graco shall not be liable for general wear and tear, or any malfunction, damage or wear caused by faulty installation, misapplication, abrasion, corrosion, inadequate or improper maintenance, negligence, accident, tampering, or substitution of non-Graco component parts. Nor shall Graco be liable for malfunction, damage or wear caused by the incompatibility of Graco equipment with structures, accessories, equipment or materials not supplied by Graco, or the improper design, manufacture, installation, operation or maintenance of structures, accessories, equipment or materials not supplied by Graco.

This warranty is conditioned upon the prepaid return of the equipment claimed to be defective to an authorized Graco distributor for verification of the claimed defect. If the claimed defect is verified, Graco will repair or replace free of charge any defective parts. The equipment will be returned to the original purchaser transportation prepaid. If inspection of the equipment does not disclose any defect in material or workmanship, repairs will be made at a reasonable charge, which charges may include the costs of parts, labor, and transportation.

THIS WARRANTY IS EXCLUSIVE, AND IS IN LIEU OF ANY OTHER WARRANTIES, EXPRESS OR IMPLIED, INCLUDING BUT NOT LIMITED TO WARRANTY OF MERCHANTABILITY OR WARRANTY OF FITNESS FOR A PARTICULAR PURPOSE.

Graco's sole obligation and buyer's sole remedy for any breach of warranty shall be as set forth above. The buyer agrees that no other remedy (including, but not limited to, incidental or consequential damages for lost profits, lost sales, injury to person or property, or any other incidental or consequential loss) shall be available. Any action for breach of warranty must be brought within two (2) years of the date of sale.

GRACO MAKES NO WARRANTY, AND DISCLAIMS ALL IMPLIED WARRANTIES OF MERCHANTABILITY AND FITNESS FOR A PARTICULAR PURPOSE, IN CONNECTION WITH ACCESSORIES, EQUIPMENT, MATERIALS OR COMPONENTS SOLD BUT NOT MANUFACTURED BY GRACO. These items sold, but not manufactured by Graco (such as electric motors, switches, hose, etc.), are subject to the warranty, if any, of their manufacturer. Graco will provide purchaser with reasonable assistance in making any claim for breach of these warranties.

In no event will Graco be liable for indirect, incidental, special or consequential damages resulting from Graco supplying equipment hereunder, or the furnishing, performance, or use of any products or other goods sold hereto, whether due to a breach of contract, breach of warranty, the negligence of Graco, or otherwise.

VOOR NEDERLANDSE GRACO-KLANTEN

Partijen verklaren te zijn overeengekomen dat het onderhavige document, alsmede alle documenten, kennisgevingen en gerechtelijke handelingen hieruit voortvloeiende of direct of indirect hiermee verband houdende, in de Engelse taal dienen te worden gesteld.

POUR LES CLIENTS FRANÇAIS DE GRACO

Les parties reconnaissent avoir convenu que le présent document sera rédigé en anglais ainsi que tous les actes, avis et procédures judiciaires afférents passés, notifiés ou engagés, en rapport, direct ou indirect, avec lui.

FÜR DEUTSCHE GRACO-KUNDEN

Die Parteien bestätigen, daß sie festgelegt haben, daß das vorliegende Dokument sowie alle anderen Dokumente, Mitteilungen und Gerichtsverfahren, die im Zusammenhang damit erstellt, verteilt oder eingeleitet werden, oder sich direkt oder indirekt darauf beziehen, in englischer Sprache sein sollen.

**ADDITIONAL WARRANTY COVERAGE / AANVULLENDE GARANTIEDEKKING
COUVERTURE DE GARANTIE SUPPLÉMENTAIRE / ZUSÄTZLICHER GARANTIEUMFANG**

Graco does provide extended warranty and wear warranty for products described in the "Graco Contractor Equipment Warranty Program".

Graco biedt aanvullende garantie en garantie wat betreft slijtage voor producten beschreven in de "Graco Contractor Equipment Warranty Program".

Graco accorde une garantie étendue aux produits décrits dans le "Programme de garantie du matériel sous-traité par Graco" et s'en porte garant.

Graco gewährt eine erweiterte Garantie und eine Verschleißgarantie für die im "Garantieprogramm für Graco-Contractorgeräte" beschriebenen Produkte.

TO PLACE AN ORDER OR FOR SERVICE, contact your Graco distributor.

OM EEN ORDER TE PLAATSEN OF VOOR SERVICE: Bel uw Graco-verdeler.

POUR PASSER COMMANDE OU UNE OPÉRATION D'ENTRETIEN, contactez votre distributeur Graco.

FÜR EINE BESTELLUNG ODER EINE SERVICE-ANFORDERUNG nehmen Sie bitte mit Ihrem Graco-Händler Kontakt auf.

All written and visual data contained in this document reflects the latest product information available at the time of publication. Graco reserves the right to make changes at any time without notice.

Alle geschreven en afgebeelde gegevens in dit document geven de meest recente productinformatie weer zoals bekend op het tijdstip van publicatie. Graco behoudt zich het recht voor op elk moment wijzigingen aan te brengen zonder voorafgaande kennisgeving.

Toutes les données écrites ou visibles dans le présent document représentent les dernières informations sur le produit disponibles au moment de la publication. Graco se réserve le droit de procéder à toute modification à tout moment sans avertissement.

Die in dieser Dokumentation enthaltenen Daten entsprechen dem Stand zum Zeitpunkt der Drucklegung. Änderungen vorbehalten.

Sales Offices: Minneapolis, Detroit

Foreign Offices: Belgium, England, Korea, France, Germany, Hong Kong, Japan

Verkoopkantoren: Minneapolis, Detroit,

Buitenlandse vestigingen: België, Engeland, Korea, Frankrijk, Duitsland, Hong Kong, Japan

Bureau de vente: Minneapolis, Detroit

Bureaux à l'étranger: Belgique, Angleterre, Corée, France, Allemagne, Hong-Kong, Japon

Verkaufszentralen: Minneapolis, Detroit

Auslandszentralen: Belgien, England, Korea, Frankreich, Deutschland, Hong Kong, Japan

GRACO INC. P.O. BOX 1441 MINNEAPOLIS, MN 55440-1441

<http://www.graco.com>

PRINTED IN USA 308853 March 1998, Revised September 1999