



This manual contains important warnings and information.  
**READ AND KEEP FOR REFERENCE.**

INSTRUCTIONS

4.0 HORSEPOWER, GASOLINE-POWERED

## GM3500 Airless Paint Sprayer

3000 psi (210 bar, 21 MPa) Maximum Working Pressure

### Model 231-579, Series A

Basic Sprayer with Lo-Boy Cart

### Model 231-077

Same as 231-579, with hose and gun, RAC IV®  
Dripless™ Tip Guard, and 517 size SwitchTip™

### Model 231-578, Series A

Basic Upright Sprayer

### Model 231-057

Same as 231-578, with hose and gun, RAC IV®  
Dripless™ Tip Guard, and 517 size SwitchTip™

CE

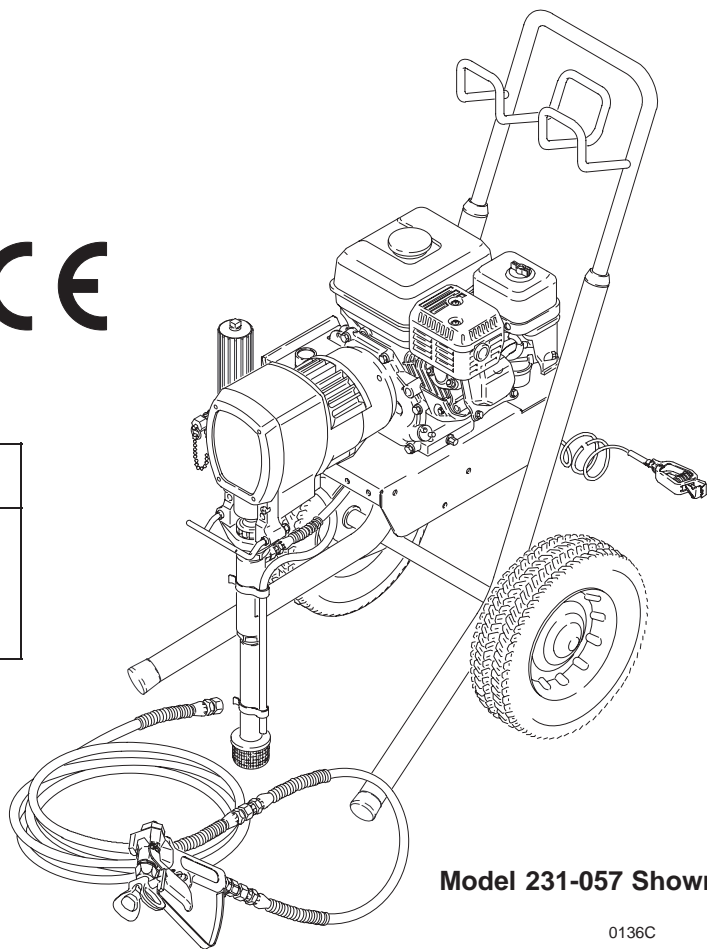

Model 231-057 Shown

0136C

### ⚠ CAUTION

Always use a minimum hose length of 50 foot (15 m) 1/4 inch ID or 50 foot (15 m) 3/8 inch ID. An undersized hose may result in poor equipment performance and damage to the clutch.

# Table of Contents

Warnings .....	2	Engine .....	23
Component Identification and Function .....	5	Field & Wiring Harness .....	24
Setup .....	6	Clamp .....	25
Fueling .....	8	Clutch Housing .....	25
Startup .....	9	Reassembly .....	26
Maintenance .....	11	Parts	
Flushing .....	12	Basic Lo-Boy Cart .....	28
Suction Tube Storage .....	13	Basic Upright Sprayer .....	30
Troubleshooting .....	14	Pinion Assembly .....	32
Pressure Control .....	16	Pressure Control .....	33
Displacement Pump .....	17	Accessories .....	34
Bearing Housing and Connecting Rod .....	18	Technical Data .....	35
Drive Housing .....	19	Dimensions .....	35
Pinion, Clutch, Clamp, Field & Engine .....	20	Graco Phone Number .....	35
Pinion Housing .....	21	Graco Warranty .....	36
Clutch .....	22		

## Symbols

### Warning Symbol



This symbol alerts you to the possibility of serious injury or death if you do not follow the instructions.

### Caution Symbol



This symbol alerts you to the possibility of damage to equipment if you do not follow the instructions.

## WARNING



INSTRUCTIONS

### EQUIPMENT MISUSE HAZARD

Equipment misuse can cause the equipment to rupture or malfunction and result in serious injury.

- This equipment is for professional use only.
- Read all instruction manuals, tags, and labels before operating the equipment.
- Use the equipment only for its intended purpose. If you are not sure, call your Graco distributor.
- Do not alter or modify this equipment. Use only genuine Graco parts.
- Check equipment daily. Repair or replace worn or damaged parts immediately.
- Do not exceed the maximum working pressure of the lowest rated system component. Refer to the **Technical Data** on page 35 for the maximum working pressure of this equipment.
- Use fluids and solvents which are compatible with the equipment wetted parts. Refer to the **Technical Data** section of all equipment manuals. Read the fluid and solvent manufacturer's warnings.
- Do not use hoses to pull equipment.
- Route hoses away from traffic areas, sharp edges, moving parts, and hot surfaces. Do not expose Graco hoses to temperatures above 82°C (180°F) or below -40°C (-40°F).
- Do not lift pressurized equipment.
- Comply with all applicable local, state, and national fire, electrical, and safety regulations.
- Wear hearing protection when operating this equipment.

# WARNING



## INJECTION HAZARD

Spray from the gun, leaks or ruptured components can inject fluid into your body and cause extremely serious injury, including the need for amputation. Fluid splashed in the eyes or on the skin can also cause serious injury.

- Fluid injected into the skin may look like just a cut, but it is a serious injury. **Get immediate medical attention.**
- Do not point the gun at anyone or at any part of the body.
- Do not put your hand or fingers over the spray tip.
- Do not stop or deflect leaks with your hand, body, glove or rag.
- Do not “blow back” fluid; this is not an air spray system.
- Always have the tip guard and the trigger guard on the gun when spraying.
- Check the gun diffuser operation weekly. Refer to the gun manual.
- Be sure the gun trigger safety operates before spraying.
- Lock the gun trigger safety when you stop spraying.
- Follow the **Pressure Relief Procedure** on page 12 if the spray tip clogs and before cleaning, checking or servicing the equipment.
- Tighten all fluid connections before operating the equipment.
- Check the hoses, tubes, and couplings daily. Replace worn or damaged parts immediately. Do not repair high pressure couplings; you must replace the entire hose.
- Fluid hoses must have spring guards on both ends, to help protect them from rupture caused by kinks or bends near the couplings.



## TOXIC FLUID HAZARD

Hazardous fluid or toxic fumes can cause serious injury or death if splashed in the eyes or on the skin, inhaled, or swallowed.

- Know the specific hazards of the fluid you are using.
- Store hazardous fluid in an approved container. Dispose of hazardous fluid according to all local, state and national guidelines.
- Always wear protective eyewear, gloves, clothing and respirator as recommended by the fluid and solvent manufacturer.



## FUEL HAZARD

The fuel used in this unit is combustible and when spilled on a hot surface can ignite and cause a fire.

- Do not fill the fuel tank while the engine is running or hot.



## EXHAUST HAZARD

The exhaust contains poisonous carbon monoxide which is colorless and odorless.

- Do not operate this equipment in a closed building.

# ! WARNING



## FIRE AND EXPLOSION HAZARD

Improper grounding, poor ventilation, open flames or sparks can cause a hazardous condition and result in a fire or explosion and serious injury.



- If there is any static sparking or you feel an electric shock while using this equipment, **stop spraying immediately**. Do not use the equipment until you identify and correct the problem.
- Provide fresh air ventilation to avoid the buildup of flammable fumes from solvents or the fluid being sprayed.
- Keep the spray area free of debris, including solvent, rags, and gasoline.
- Disconnect all electrical equipment in the spray area.
- Extinguish all open flames or pilot lights in the spray area.
- Do not smoke in the spray area.
- Do not turn on or off any light switch in the spray area while operating or if fumes are present.
- Do not operate a gasoline engine in the spray area.
- Ground the sprayer to a true earth ground with the ground wire and clamp (supplied).
- Use only electrically conductive hoses.
- Do not use 1,1,1-trichloroethane, methylene chloride, other halogenated hydrocarbon solvents or fluids containing such solvents in pressurized aluminum equipment. Such use could result in a chemical reaction, with the possibility of explosion.



## MOVING PARTS HAZARD

Moving parts can pinch or amputate your fingers.

- Keep clear of all moving parts when starting or operating the sprayer.
- Before servicing the equipment, follow the **Pressure Relief Procedure** on page 12 to prevent the equipment from starting unexpectedly.

**NOTE:** This is an example of the DANGER label on your sprayer. This label is available in other languages, free of charge. See page 34 to order.

! <b>DANGER</b> !			
	<b>FIRE AND EXPLOSION HAZARD</b>		<b>SKIN INJECTION HAZARD</b>
<p>Spray painting, flushing or cleaning equipment with flammable liquids in confined areas can result in fire or explosion.</p> <p>Use outdoors or in extremely well ventilated areas. Ground equipment, hoses, containers and objects being sprayed.</p> <p>Avoid all ignition sources such as static electricity from plastic drop cloths, open flames such as pilot lights, hot objects such as cigarettes, arcs from connecting or disconnecting power cords or turning light switches on and off.</p> <p>Failure to follow this warning can result in death or serious injury.</p>		<p>Liquids can be injected into the body by high pressure airless spray or leaks – especially hose leaks.</p> <p>Keep body clear of the nozzle. Never stop leaks with any part of the body. Drain all pressure before removing parts. Avoid accidental triggering of gun by always setting safety latch when not spraying.</p> <p>Never spray without a tip guard.</p> <p>In case of accidental skin injection, seek immediate “Surgical Treatment”.</p> <p>Failure to follow this warning can result in amputation or serious injury.</p>	
<b>READ AND UNDERSTAND ALL LABELS AND INSTRUCTION MANUALS BEFORE USE</b>			

# Component Identification and Function

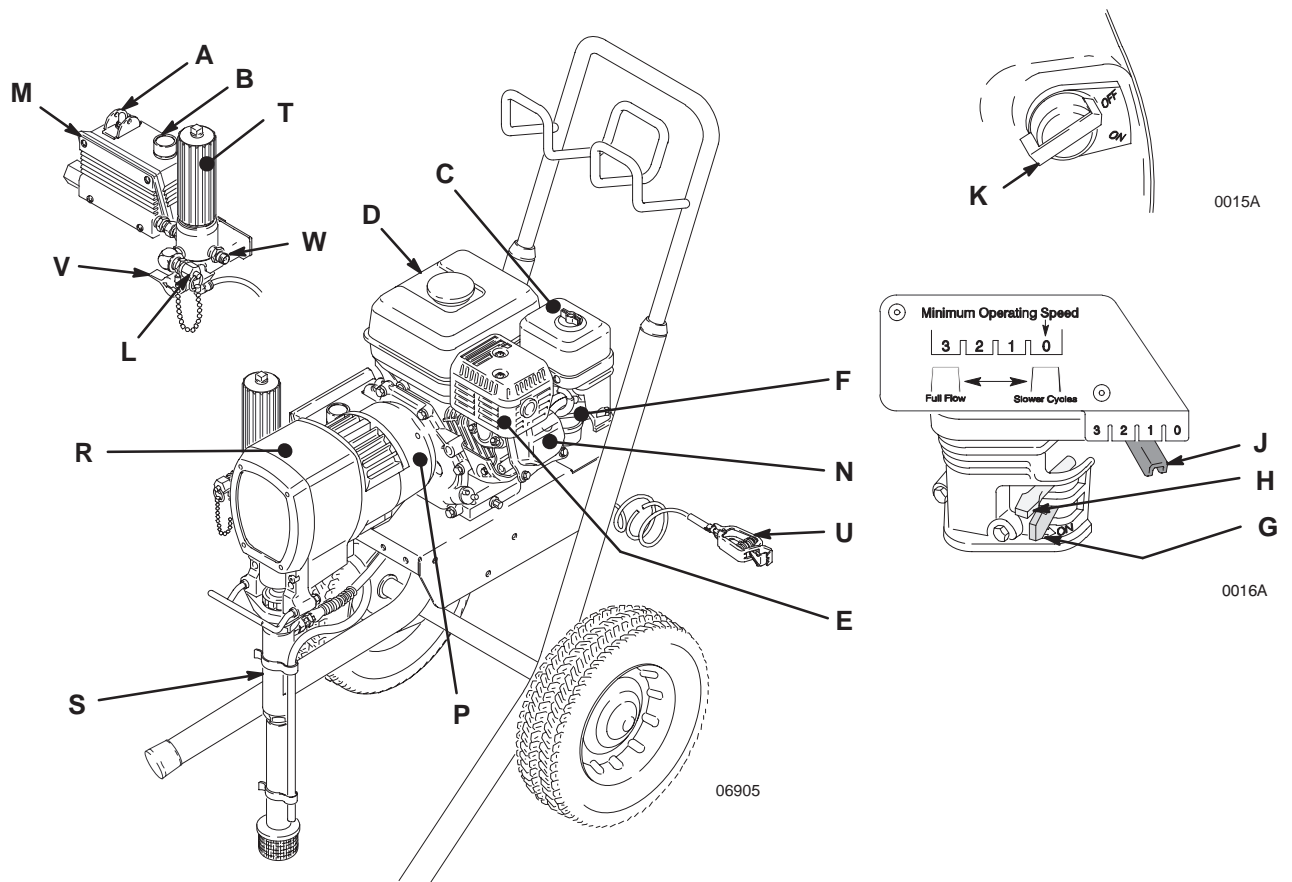

Fig. 1

<b>A</b>	Pressure Control Switch	ON/OFF, enables/disables clutch function
<b>B</b>	Pressure Adjusting Knob	Controls fluid outlet pressure
<b>C</b>	Air Cleaner*	Filters air entering the carburetor
<b>D</b>	Fuel Tank*	Holds 0.66 gallons (2.5 liters) of [(R+M)/2]; 86 octane gasoline
<b>E</b>	Muffler*	Reduces noise of internal combustion
<b>F</b>	Spark Plug Cable*	Routes electrical current to spark plug
<b>G</b>	Fuel Valve*	On/off valve to regulate fuel flow from gasoline tank to carburetor
<b>H</b>	Choke*	Enriches air/gasoline mixture for cold starting
<b>J</b>	Throttle*	Adjusts engine speed for large or small orifice spray tips
<b>K</b>	Engine Switch*	Enables/disables engine operation
<b>L</b>	Secondary Fluid Outlet	Secondary Hose and spray gun are connected here
<b>M</b>	Pressure Control	Controls clutch cycling to maintain fluid pressure.
<b>N</b>	Engine*	4.0 HP gasoline engine
<b>P</b>	Clutch	Transfers power from engine to drive assembly
<b>R</b>	Drive Assembly	Transfers power from clutch to displacement pump
<b>S</b>	Displacement Pump	Provides fluid to be sprayed through spray gun
<b>T</b>	Fluid Filter	Filters fluid between source and spray gun
<b>U</b>	Grounding Clamp and Wire	Grounds sprayer system
<b>V</b>	Pressure Drain Valve	Relieves fluid pressure when open
<b>W</b>	Primary Fluid Outlet	Hose and spray gun are connected here
*	For more detailed explanations of these controls, refer to the Honda engine manual; supplied	

# Setup

## ⚠ WARNING

If you supply your own hoses and spray gun, be sure the hoses are electrically conductive, that the gun has a tip guard, and that each part is rated for at least *3000 psi (210 bar, 21 MPa) Maximum Working Pressure*. This is to reduce the risk of serious bodily injury caused by static sparking, fluid injection or over-pressurization and rupture of the hose or gun.

## ⚠ CAUTION

To avoid damaging the pressure control, follow these precautions.

1. Always use nylon spray hose at least 50 ft (15.2 m) long.
2. Never use a wire braid hose; it is too rigid to act as a pulsation dampener.
3. Never install a ball valve or shutoff device between the filter and the 50 ft (15 m) hose.
4. Always use the main filter outlet for one gun operation. Never plug this outlet.

1. **Connect hose and gun.** Remove the plastic cap plug from the 1/4 npsm(m) outlet nipple (W). Assemble the 50 ft (15 m) hose (121), 3 ft (0.9 m) whip hose (122) and gun (123), and connect them to the outlet nipple.
2. **DO NOT** use thread sealant on the hose and gun connections. **DO NOT** install the spray tip until the system is primed.
3. **Two gun hookup.** Unscrew the cap (L) from the secondary hose outlet. Connect an accessory hose and gun to the 1/4 npsm(m) nipple.
4. **Fill the packing nut/wet-cup (216)** 1/3 full with Graco Throat Seal Liquid (TSL), supplied, and keep it filled, to help extend the pump life.

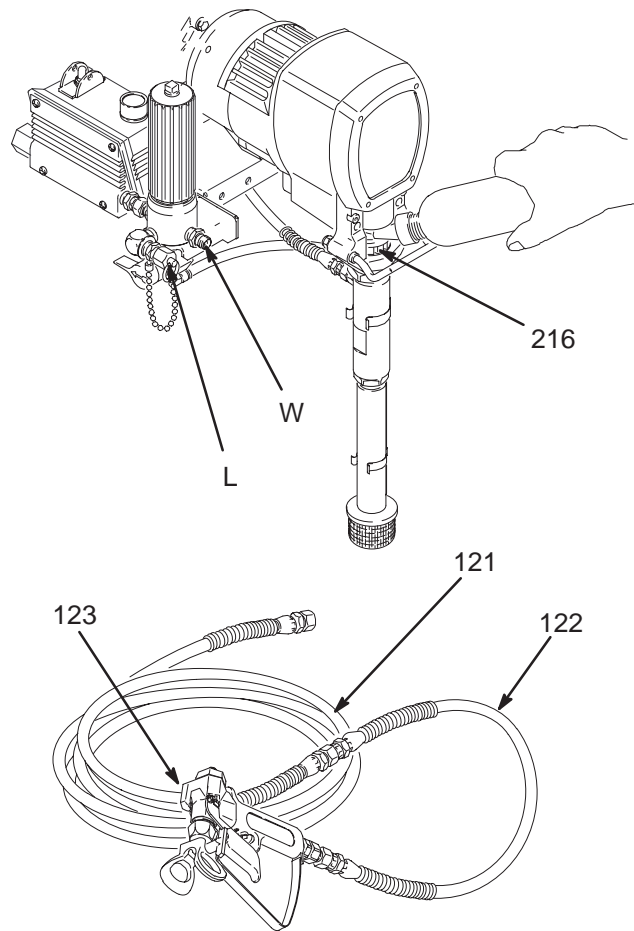

Fig. 2

06882

# Setup

5. **Check the engine oil level.** Refer to the Honda engine manual, supplied. This is a summary of the information: Remove one of the oil fill plugs; (C) the oil should be almost overflowing. See Fig. 3. Add oil as necessary.

Recommended lubrication oil: Use a high-quality, detergent oil, SAE 10W-40, classified "FOR SERVICE SE or SF", for regular use and for breaking-in a new engine.

6. **Be sure your system is properly grounded before operating it.** Read and follow the warning section, **Fire Or Explosion Hazard**, page 4. Use the ground wire (47) provided.
7. **Fill the gas tank.** See the **Fueling** section, below.
8. **Flush the pump** to remove the lightweight oil which was left in the pump to protect it from rust. Refer to the **Flushing**, page 12.
9. **Prepare the paint** according to the manufacturer's recommendations. Remove any skin that may have formed. Stir the paint to mix pigments.
10. **Strain the paint** through a fine nylon mesh bag (available at most paint dealers) to remove particles that could clog the filter or spray tip. This is probably the most important step toward trouble-free spraying.

11. **Keep the sprayer upright and level** during operation and whenever it is being moved. Read the last **CAUTION** on page 10.

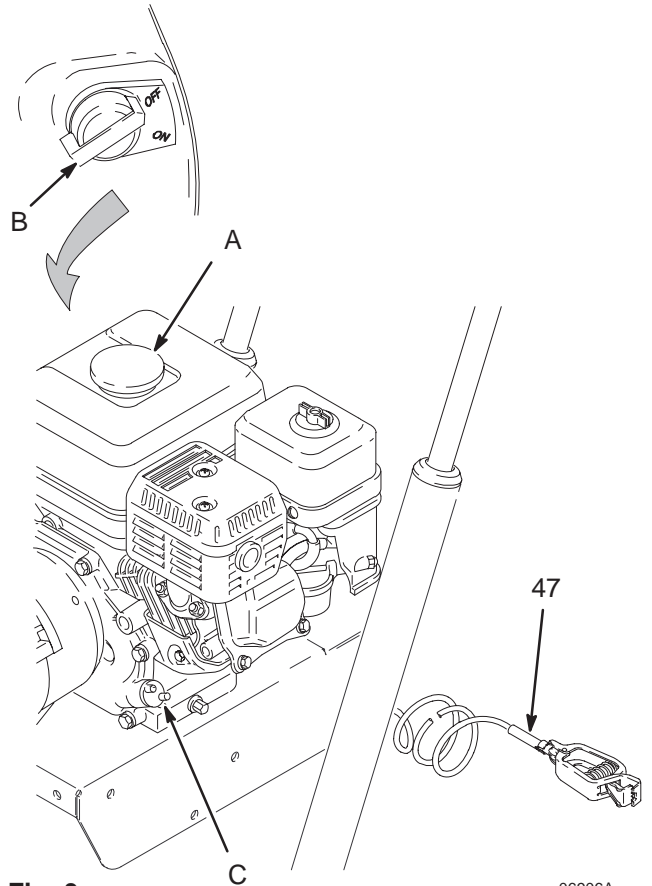

Fig. 3

06906A



# Fueling

## **WARNING**

Gasoline is extremely flammable and explosive under certain conditions. To reduce the risk of a fire or explosion:

- Always shut off the engine (B) before refueling.
- Refuel in a well-ventilated area.
- Do not smoke or allow flames or sparks in the area where the engine is refueled or where the gasoline is stored.
- Do not overfill the tank. Make sure the filler cap is securely closed after refueling.
- Be careful not to spill fuel when fueling. Fuel vapor or spilled fuel can ignite. If any fuel is spilled, make sure the area is dry before starting the engine.

1. **Fuel specifications.** Use automotive gasoline with a pump octane number of 86 or higher. If the engine knocks or pings, use a higher octane gasoline. Unleaded fuel minimizes combustion chamber deposits.

2. **Gasolines containing alcohol (gasohol).** Do not use gasohol which contains methanol, if the gasohol does not contain cosolvents and corrosion inhibitors for methanol. Even if it does contain such additives, do not use the gasohol if it contains more than 5% methanol.

**NOTE:** The HONDA engine warranty does not cover damage resulting from the use of gasolines containing alcohol. See the HONDA engine manual for more information.

3. **General.** Do not use oil and gasoline mixtures or contaminated gasoline. Avoid getting dirt, dust or water in the fuel tank.
4. **Tank Capacity.** 0.66 gallons (2.5 liter). Always leave at least 1/2 in. at the top of the tank for expansion.
5. **Shut off the engine before refueling.**
6. **After refueling, tighten the fuel tank cap (A) firmly.**



# Startup

**NOTE:** Refer to Fig. 1 as you start the sprayer.

**NOTE:** When starting a sprayer that IS NOT PRIMED, remove the spray tip.

1. **Be sure the gas tank is full.** Open the black fuel shutoff lever (G).
2. **Check the engine oil level.**

**NOTE:** The engine stops automatically if it is low on oil. If you try to start it again without adding more oil, a red light on the rear of the engine glows as you pull the starter rope.

3. **Place the suction tube (S) into the paint container.**
4. **Turn the pressure control switch (A) to OFF.**
5. **Open the black fuel shutoff lever (G) by pushing it in the direction of the arrow.**
6. **Be sure the spark plug cable (F) is firmly pushed onto the spark plug.**

## CAUTION

Never attempt to start the engine unless fluid pressure is relieved and the pressure control is turned OFF. Attempting to start the engine when it is pressurized will damage the recoil system.

## 7. To start the engine:

- a. **Turn the pressure adjusting knob (B)** all the way counterclockwise to the lowest pressure setting.
- b. **Pull the metal throttle lever (J) away from the fuel tank** to the maximum position (fully left).
- c. **If the engine is cold**, close the gray choke lever (H), located beneath the air cleaner.

**If the engine is warm**, close the choke only half way or not at all.

- d. **Turn the engine switch to ON.**

## WARNING

A rope which recoils too quickly may hit someone and cause serious bodily injury. The rope could also jam in the recoil assembly.

- e. **Grasp the starter rope.** Holding the frame of the sprayer with one hand, pull the rope rapidly and firmly. Continue holding the rope as you let it return. Pull and return the rope until the engine starts.
- f. **Open the choke (H) as soon as the engine starts.** In cold weather, leave the choke closed for 10 to 30 seconds before opening it to keep the engine running.

8. **Disengage the gun safety latch.** See Fig. 4.

# Startup

## 9. To start the pump:

- a. Open the pressure drain valve (V).
- b. Turn the pressure control switch (A) to ON.
- c. Slowly increase the pressure knob (B) until the pump starts to cycle slowly. Cycle the pump slowly until fluid is flowing smoothly from the pressure drain valve, indicating the pump is fully primed.
- d. Close the pressure drain valve (V).
- e. Hold a metal part of the gun firmly against a grounded metal container, squeeze the trigger until fluid is flowing smoothly from the gun.
- f. Release the trigger and engage the gun safety latch.

## **⚠ WARNING**

To reduce the risk of serious bodily injury from fluid injection, NEVER operate the spray gun with the tip guard removed.

10. **Install the spray tip.** Refer to the instruction manual supplied with the tip (307–848 if you are using a RAC IV).
11. **Adjust the engine speed and pump pressure.** Trigger the gun onto a test paper to check the spray pattern and atomization. Turn the pressure adjusting knob (B) until you get a good pattern. Then slowly lower the throttle (J) setting as far as you can without changing the spray pattern.

## **⚠ CAUTION**

Always use the lowest needed fluid pressure and the lowest needed throttle (J) setting, to increase the life of the sprayer. Higher settings cause excessive clutch cycling, premature tip wear and premature pump wear.

## **⚠ CAUTION**

Close the fuel valve (G) when transporting the sprayer to prevent fuel from flooding the engine.

Keep the sprayer upright and level when operating it and when transporting it. This prevents crankcase oil from leaking into the combustion chamber, which makes start up very difficult.

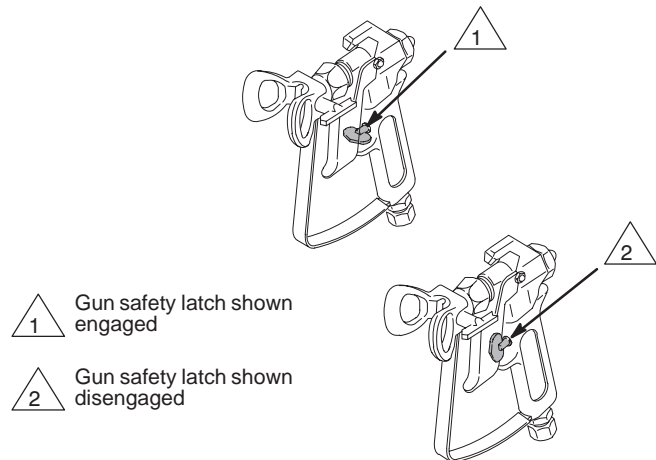

**Fig. 4**

0137

# Maintenance

## **WARNING**

To reduce the risk of serious bodily injury always follow the **Pressure Relief Procedure Warning** on page 12 before checking, adjusting, cleaning or shutting down the sprayer.

## **CAUTION**

For detailed engine maintenance and specifications, refer to the separate engine manual.

**DAILY:** Check the engine oil level and fill as necessary.

**DAILY:** Check and fill the gas tank.

**AFTER THE FIRST 20 HOURS OF OPERATION AND EACH 100 HOURS THEREAFTER:** Change the oil.

**WEEKLY:** Remove the air filter cover and clean the element. In very dusty environments, check the filter daily. Replace the element as needed. Replacement elements can be purchased from your local HONDA dealer.

**WEEKLY:** Check the level of the TSL in the displacement pump packing nut. Fill the nut, if necessary. Keep TSL in the nut to help lubricate the pump packings.

**SPARK PLUG:** Use only a BPR6ES (NGK) or W20 EPR-U (NIPPON DENSO) plug. Gap the plug to 0.028 to 0.031 in. (0.7 to 0.8 mm). Always use a spark plug wrench.

# Pressure Relief Procedure

## WARNING



### INJECTION HAZARD

The system pressure must be manually relieved to prevent the system from starting or spraying accidentally. Fluid under high pressure can be injected through the skin and cause serious injury. To reduce the risk of an injury from injection, splashing fluid, or moving parts, follow the **Pressure Relief Procedure** whenever you:

- are instructed to relieve the pressure,
- stop spraying,
- check or service any of the system equipment,
- install or clean the spray tip.

1. Engage the gun safety latch.
2. Turn the engine switch to OFF.
3. Move the pressure control ON/OFF switch to OFF.
4. Disengage the gun safety latch. Hold a metal part of the gun firmly to a grounded metal pail. Trigger the gun to relieve pressure.
5. Engage the gun safety latch.
6. Open the pressure drain valve. Leave the pressure drain valve open until you are ready to spray again.
7. Disconnect the spark plug cable.

If you suspect that the spray tip or hose is completely clogged, or that pressure has not been fully relieved after following the steps above, **VERY SLOWLY** loosen the tip guard retaining nut or hose end coupling to Relieve the pressure gradually, then loosen completely. Now clear the tip or hose.

## Flushing

**NOTE:** Several flushes are often required to thoroughly clean the system and prepare it for the next fluid to be sprayed, or to store the sprayer. Use this chart to determine the required flushing order for the fluid you are using, and then follow the procedure below for flushing.

\*Use this category for flushing a brand new sprayer and flushing after storage.

System has this fluid in it:	Next fluid to be sprayed.	Flushing order:			Before you spray or store sprayer:
		Flush 1	Flush 2	Flush 3	
*Oil-based solvent or paint	Oil-based paint – new color	Mineral spirits	none	none	Prime with oil-based paint
Oil-based solvent or paint	Water-based paint	Mineral spirits	Warm soapy water	Clean water	Prime with water-based paint
Oil-based solvent or paint	Prepare for storage	Mineral spirits	none	none	Relieve pressure, Leave drain valve open
Water or water-based paint	Water-based paint – new color	Warm soapy water	Clean water	none	Prime with water
Water or water-based paint	Oil-based paint	Warm soapy water	Clean water	Mineral spirits	Prime with oil
Water or water-based paint	Prepare for storage	Warm soapy water	Clean water	Mineral spirits	Relieve pressure, Leave drain valve open

# Flushing

## ⚠ CAUTION

NEVER allow water to freeze in the pressure control. Doing so prevents the sprayer from being started and causes serious damage to the pressure control. Pump the water out with mineral spirits.

## ⚠ WARNING



### FIRE AND EXPLOSION HAZARD

To reduce the risk of static sparking and splashing when flushing, always remove the spray tip from the gun and hold a metal part of the gun firmly to the side of a grounded metal pail.

1. Follow the **Pressure Relief Procedure** on page 12. Engage the gun safety latch.
2. Turn the pressure adjusting knob fully counter-clockwise to the minimum pressure.
3. Remove the spray tip from the gun. Remove the filter bowl (A) and screen (B); see manual 307–273. Clean the screen separately and install the bowl without the screen to flush it. See Fig. 5.
4. Put the suction tube into a grounded metal pail with 1/2 gallon of compatible solvent.

5. Start the sprayer. See page 10. To save the fluid in the sprayer, trigger the gun into another container until the next fluid appears, then trigger the gun back into the fluid you are pumping. Circulate the flushing fluid to thoroughly clean the system.
6. Remove the strainer (and suction tube, if used) and clean separately to remove all paint sediment.
7. Do not run the pump dry for more than 30 seconds to avoid damaging the pump packings!
8. Follow the **Pressure Relief Procedure** on page 12. Engage the gun safety latch.
9. Unscrew the filter bowl and reinstall the clean screen. Install the bowl and hand tighten. Install the suction tube assembly.

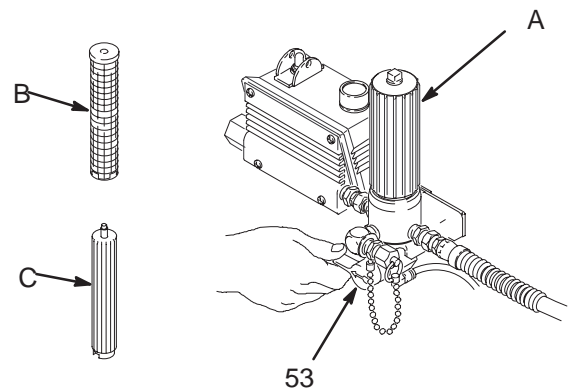

Fig. 5

06878

## Suction Tube Storage

Place the suction tube in the receptacle on the cart frame as shown in Fig. 6.

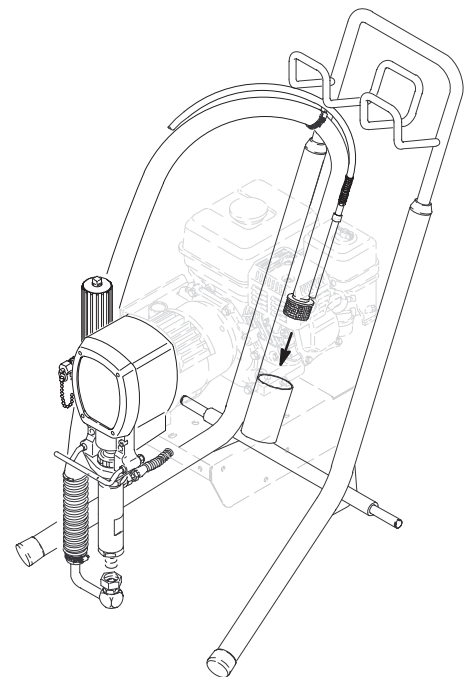

Fig. 6

06970

# Troubleshooting

## WARNING

To reduce the risk of serious bodily injury always follow the **Pressure Relief Procedure Warning** on page 12 before checking, adjusting, cleaning or shutting down the sprayer.

Check everything in the chart before disassembling the sprayer. (Continued on page 15)

PROBLEM	CAUSE	SOLUTION
Engine/sprayer won't start	Engine switch not on	Turn on.
	Out of gas	Replenish
	Engine oil level low	Try starting engine. If light on rear of engine glows, replenish oil.
	Spark plug cable disconnected or spark plug damaged	Connect cable on top of engine or replace spark plug. See Fig. 1, page 5.
	Water frozen in pressure control	Return pressure control to authorized Graco dealer for repair.
Engine won't "pull over"	Oil seepage into combustion chamber	Remove spark plug. Pull starter rope 3 or 4 times. Clean and replace plug. Try to start. Keep sprayer upright to avoid oil leakage. See last <b>CAUTION</b> on page 10.
Engine operates, but displacement pump doesn't	Pressure control switch turned OFF	Turn on.
	Pressure setting too low	Increase pressure.
	Displacement pump outlet filter dirty	Clean filter.
	Tip or tip filter clogged	Clean tip or tip filter.
	Displacement pump rod seized by dry paint	Service pump. See page 18.
	Connecting rod worn or damaged	Replace. See page 18.
	Drive housing worn or damaged	Replace. See page 19.
	Electrical power not energizing field	Check wiring connections. See pages 16 and 33. With pressure control switch ON and pressure turned to MAXIMUM, use a test light to check continuity across black and white wires from pressure control. Have pressure control checked by authorized Graco dealer.
	Clutch worn or damaged	Service. See page 24.
Pinion assembly worn or damaged	Service. See page 20.	

# Troubleshooting

PROBLEM	CAUSE	SOLUTION
Displacement pump output low on upstroke	Pump inlet screen clogged	Clean.
	Piston ball check not seating	Service piston ball check. See page 18.
	Piston packings worn or damaged	Replace packings. See page 18.
	Sleeve gasket in displacement pump worn or damaged	Replace. See page 18.
Displacement pump output low on downstroke or both strokes	Pump inlet screen clogged	Clean.
	Piston packings worn or damaged	Replace packings. See page 18.
	Intake valve ball check not seating properly	Clean and service. See page 18.
	Engine RPM too low	Increase throttle setting. See <b>Startup</b> , Step 11, page 10.
	Clutch worn or damaged	Replace. See page 24.
Paint leaks into wet-cup	Loose wet-cup	Tighten just enough to stop leakage.
	Throat packings worn or damaged	Replace packings. See page 18.
	Displacement rod worn or damaged	Replace rod. See page 18.
Low fluid delivery	Pump inlet screen clogged.	Clean.
	Pressure setting too low	Increase pressure. See <b>Startup</b> , Step 11, page 10.
	Engine RPM too low	Increase throttle setting. See <b>Startup</b> , Step 11, page 10.
	Dirty outlet filter, tip filter or tip	Clean.
	Large pressure drop in hose	Use larger diameter hose.
Spitting from gun	Air in fluid pump or hose	Check for loose connections at pump intake and tighten. Then prime the pump. See <b>Startup</b> , page 10.
	Tip partially clogged	Clear.
	Fluid supply is low or empty	Refill and prime the pump. See <b>Startup</b> , page 10. Check fluid supply often to prevent running the pump dry.



# Pressure Control Replacement

## **⚠ WARNING**



### **INJECTION HAZARD**

To reduce the risk of serious injury, whenever you are instructed to relieve pressure, follow the **Pressure Relief Procedure** on page 12.

1. Relieve pressure.
2. Disconnect the pressure control while holding the fitting or elbow (A) firmly. See the **CAUTION**, below. See Fig. 7.

## **⚠ CAUTION**

Do not allow the elbow or fitting (A) to turn when removing or connecting the hoses. Turning the fitting or elbow can shift the calibration of the pressure control.

3. Remove the four mounting screws and washers (302, 303, 304) from the pressure control cover (76). See Fig. 8.
4. Carefully remove the pressure control cover (76) so as not to stress the cables.
5. Disconnect the black and white wires of the pressure control cable (314) from the pressure control cover.
6. Disconnect the potentiometer cable assembly (310) from the pressure control cover.
7. Disconnect the red power lead (B) from the ON/OFF switch.
8. Loosen the ground terminal screw (317) and disconnect the ground lead (C).
9. Pull off the pressure control cover.

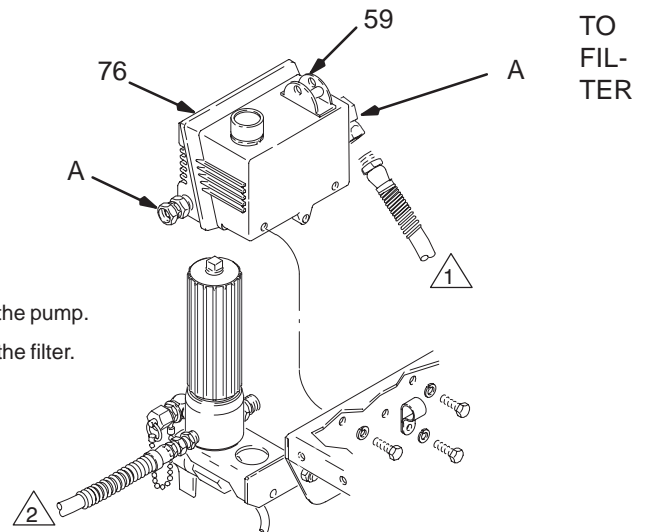

Fig. 7

06873

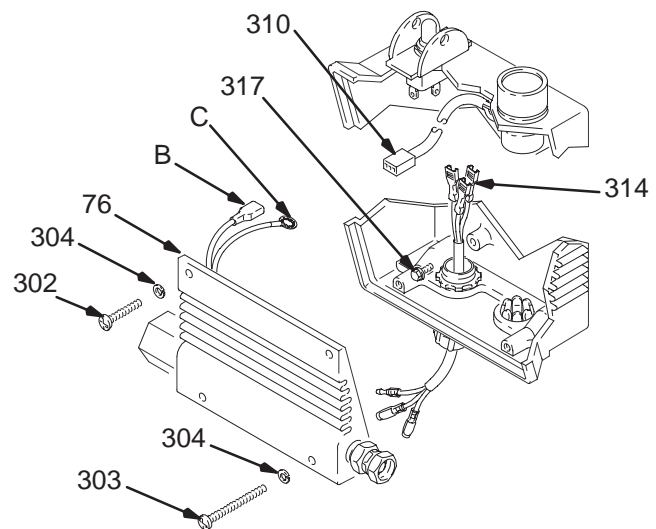

Fig. 8

06872A

## **⚠ WARNING**

Do not attempt to adjust or calibrate the pressure control. If the pressure control is faulty, replace it.

10. Reassemble in the reverse order; attach ground wire (C), power lead (B), and the black and white connectors. Attach the pressure control cover (76) using the four mounting screws and washers (302, 303, 304).

# Displacement Pump

## ⚠ WARNING

To reduce the risk of serious bodily injury always follow the **Pressure Relief Procedure Warning** on page 12 before checking, adjusting, cleaning or shutting down the sprayer.

### Removing the pump See Fig. 9.

1. Flush the pump. Relieve pressure.
2. Hold the intake valve (223) with a wrench and unscrew the suction tube (30). Remove the hose (55). **For upright carts**, remove the spring clips (90,92) and drain hose (91).
3. Push the retaining spring (26) up. Push the pin (25) out the rear.
4. Loosen the locknut (27). Unscrew the pump.

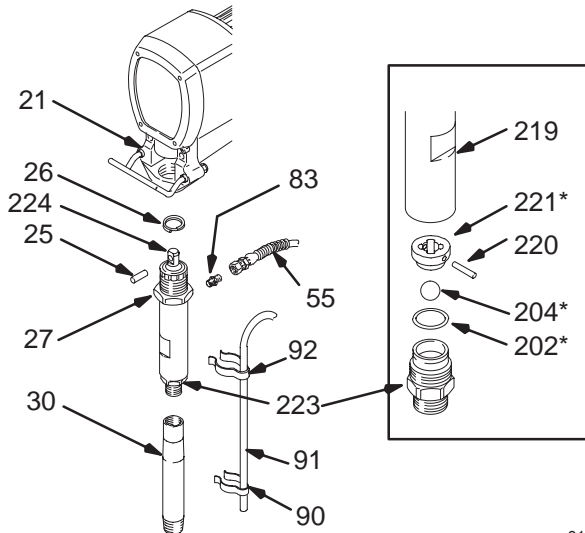

Fig. 9 01200A

### Repairing the pump

See Displacement Pump manual 307–806 for pump repair procedures.

## ⚠ WARNING

Seat the retaining spring (26) firmly in the connecting rod groove to prevent the pin (25) from working loose due to vibration.

If the pin works loose, it or other parts could break off due to the force of the pump action. These parts could be projected through the air and result in serious injury or property damage, including the connecting rod and bearing housing.

### Installing the pump

1. Screw the pump 3/4 of the way into the bearing housing (21). Hold the pin (25) up to the pin hole in the connecting rod (22) and continue screwing in the pump until the pin slides easily into the hole.
2. Align the top threads of the pump cylinder flush with the face of the bearing housing and so the outlet nipple (83) is straight back.
3. Push the retaining spring (26) into the groove of the connecting rod, all the way around. Torque the locknut (27) to  $90 \pm 5$  ft-lb ( $120 \pm 7$  N·m).
4. Tighten the packing nut (216) only enough to stop leaking. Fill the nut 1/2 full with Graco TSL.
5. Assemble the remaining parts.

⚠ 1 Face of bearing housing

⚠ 2 Torque to  $90 \pm 5$  ft-lb ( $120 \pm 7$  N·m)

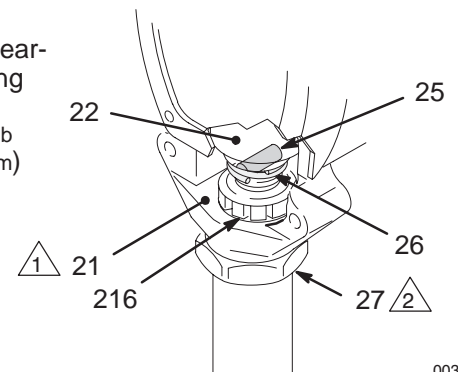

Fig. 10 0031A

# Bearing Housing and Connecting Rod

## ⚠ WARNING

To reduce the risk of serious bodily injury always follow the **Pressure Relief Procedure Warning** on page 12 before checking, adjusting, cleaning or shutting down the sprayer.

**NOTE:** Steps 1 to 10 refer to Fig. 11.

1. Remove the pump. See page 17.
2. Remove the four screws (69) and lockwashers (70) from the bearing housing (21).
3. While pulling the connecting rod assembly (22) with one hand, lightly tap the lower rear of the bearing housing (21) with a plastic mallet to loosen it from the drive housing (20). Pull the bearing housing and the connecting rod assembly off the drive housing.
4. Inspect the crank (A) for excessive wear and replace parts as needed.
5. Evenly lubricate the inside of the bronze bearing (C) in the bearing housing (21), and the inside of the connecting rod link (D), with high-quality motor oil. Liberally pack the roller bearing (E) in the connecting rod assembly (22) with bearing grease.
6. Assemble the connecting rod (22) and bearing housing (21).
7. Clean the mating surfaces of the bearing and drive housings.
8. Align the connecting rod with the crank (A). Align the locating pins (F) in the drive housing (20) with the holes in the bearing housing (21). Push the bearing housing onto the drive housing or tap it into place with a plastic mallet.

## ⚠ CAUTION

Use only the locating pins (F) to align or seat the bearing housing (21) with the drive housing (20).

9. Install the screws (69) and lockwashers (70) on the bearing housing. Tighten the screws evenly to  $300 \pm 20$  in-lb ( $34 \pm 2.3$  N·m).
10. Install the pump. See above.

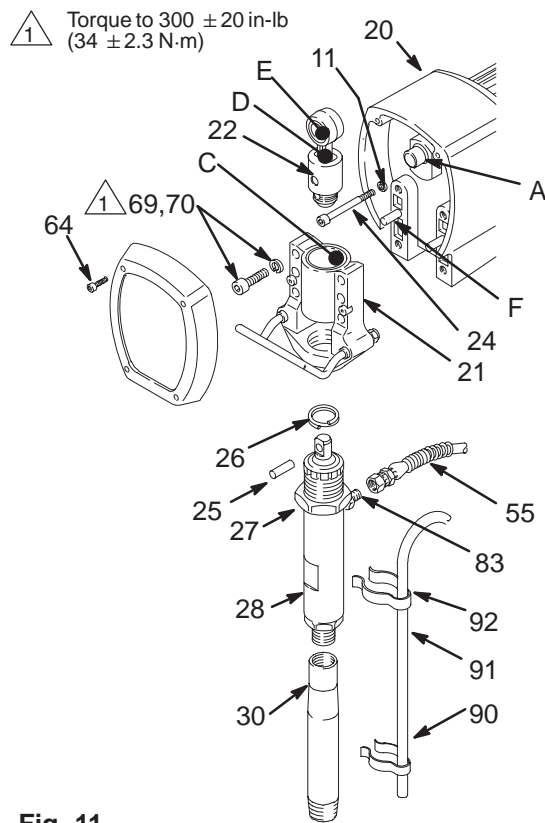

Fig. 11

0149B

# Drive Housing

## ⚠ WARNING

To reduce the risk of serious bodily injury always follow the **Pressure Relief Procedure Warning** on page 12 before checking, adjusting, cleaning or shutting down the sprayer.

**NOTE:** Refer to Fig. 12 for this procedure.

1. Remove the front cover (23).
2. Disconnect the hose (55) from the pump nipple (83). **For the upright carts only**, detach the drain hose (91) from the pump.
3. Remove the four screws (69) and lockwashers (70) from the bearing housing (21).
4. Lightly tap the back of the bearing housing with a plastic mallet. Pull the pump, bearing housing and connecting rod away from the drive housing as one assembly.
5. Remove the two screws (24) and lockwashers (11). Remove the four screws (10) and lockwashers (11).
6. Lightly tap around the drive housing (20) with a plastic mallet to loosen it from the pinion housing (19n).

## ⚠ CAUTION

**DO NOT** drop the gear cluster (18) when removing the drive housing (20). The gear cluster is easily damaged. The gear may stay engaged in either the drive housing or the pinion housing.

**DO NOT** lose the thrust balls (20c and 19j) located at each end of the gear cluster. The balls, which are heavily covered with grease, usually stay in the shaft recesses, but they could be dislodged. If they are caught between the gears and not removed, the balls will seriously damage the drive housing. If the balls are not in place, the bearings will wear prematurely.

7. Liberally apply bearing grease (20d, supplied) to the gear cluster (18). Be sure the thrust balls (20c and 19j) are in place.
8. Place the bronze colored washer (20a) and then the silver-colored washer (20b) on the shaft protruding from the big bearing of the drive housing (20). Align the gears and push the new drive housing straight onto the pinion housing and locating pins (B).
9. Starting at Step 5, work backwards to reassemble the sprayer. Or, move ahead to the next section in this manual if further service is needed.

⚠ Torque to 300 ± 20 in-lb  
(34 ± 2.3 N·m)

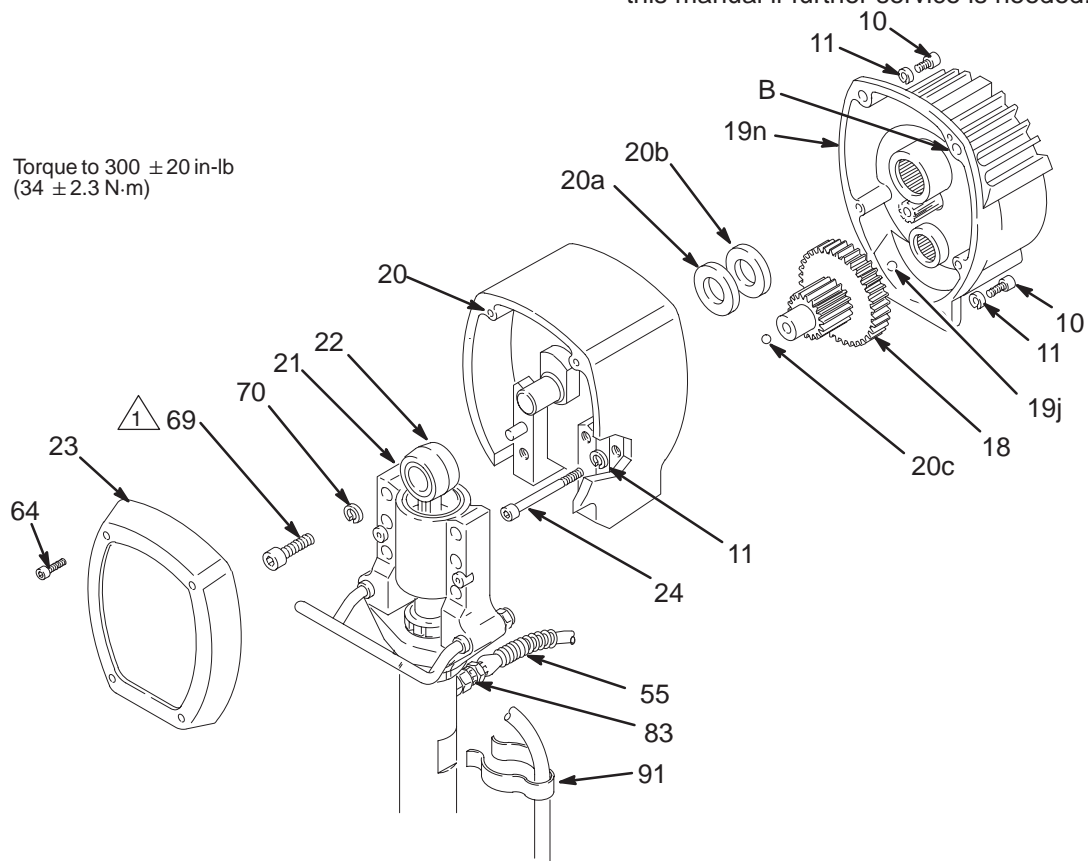

Fig. 12

0170A

# Pinion, Clutch, Clamp, Field & Engine

Disassembling these parts can start from the pinion housing or from the clutch, if no pinion service is needed.

If starting from the pinion housing, first follow Steps 1 to 6 of **Drive Housing**, on page 19, and then continue with the procedure below.

If starting from the clutch, see page 22.

## Pinion Housing

### Removing the Pinion Housing

#### **⚠ WARNING**

To reduce the risk of serious bodily injury always follow the **Pressure Relief Procedure Warning** on page 12 before checking, adjusting, cleaning or shutting down the sprayer.

**NOTE:** Refer to Fig. 13 for Steps 1 to 3, except where noted.

1. Remove the two bottom screws (10) first, and then remove the top three screws (11).

2. Pull the pinion housing (19n) away from the clutch housing (2). The armature (4a) will come with it.
3. Pull out the armature (4a).

#### **⚠ CAUTION**

Do not lose the thrust ball (19j). Refer to the **CAUTION** on page 19 for more information.

**NOTE:** To disassemble the pinion, continue with **Repairing the Pinion**, page 21. To disassemble more of the sprayer, go to page 22. To reassemble the sprayer from this point, skip ahead to **Reassembly**, page 27, Step 7.

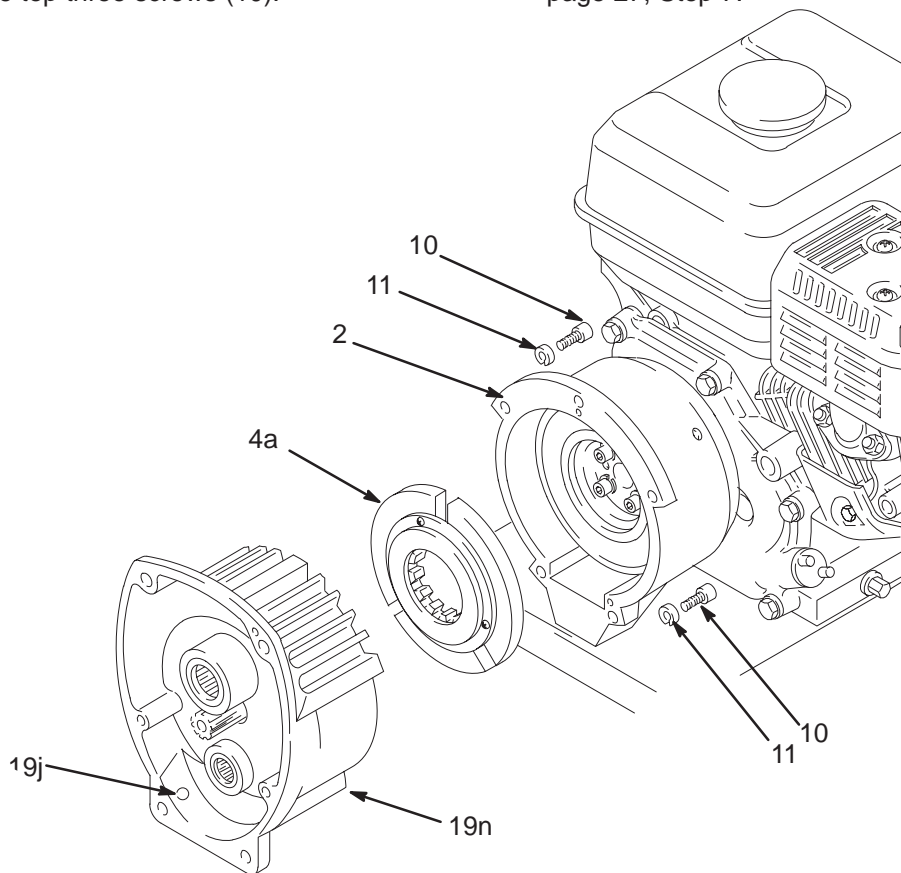

Fig. 13

0171A

# Pinion Housing

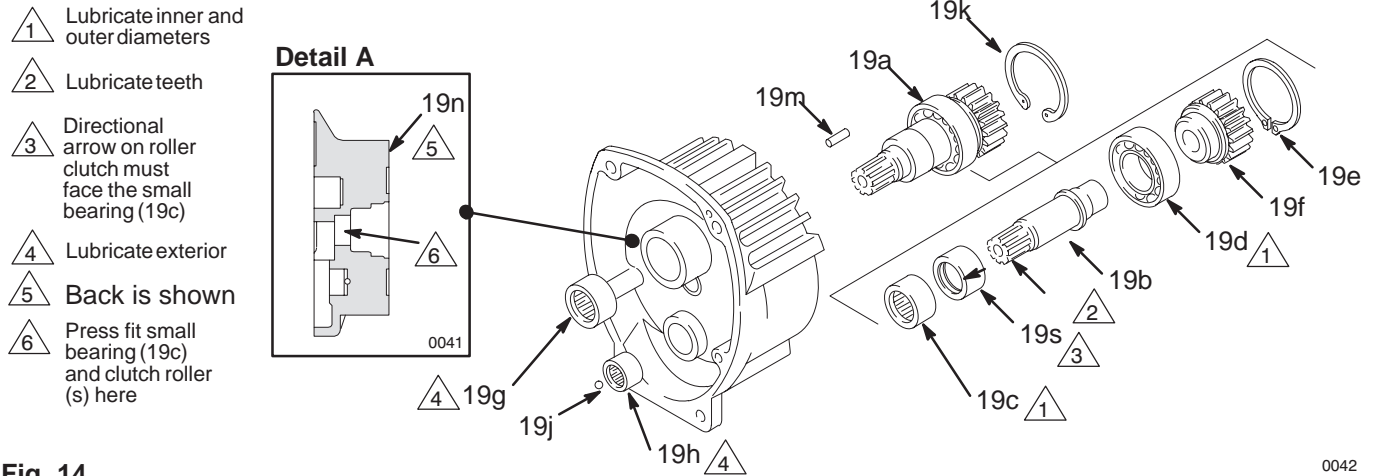

Fig. 14

0042

## Repairing the Pinion

**NOTE:** Use a hydraulic press if you purchase the pinion parts individually. Otherwise, use Repair Kit No. 223–189, which includes the shaft and bearings preassembled and lubricated.

**NOTE:** Refer to Fig. 14 except where noted.

If using Repair Kit 223–189, follow Steps 1 to 6, below.

1. Remove the small ring (19e) from the hub (19f) and the large ring (19k) from the bearing recess of the housing (19n).
2. Push on the front of the shaft (19b) to force the bearing and hub assembly out of the housing (19n).
3. Press the small bearing (19c) out of the pinion housing (19n). Remove the new bearing from the shaft of the kit and press it into the housing. See Detail A.
4. Install the shaft assembly (19a), pushing it to the shoulder of the housing (19n).
5. Install the rings (19e and 19k).
6. Go to **Reassembly**, page 27, Step 7, or continue on page 22.

If you purchased parts separately, follow steps 1 to 9, below. Disassemble only as far as needed for the parts being replaced.

**NOTE:** The old bearing (19d) will be damaged as it is removed. Have one on hand if you need to remove it for any reason.

1. If replacing the small bearing (19c) or roller clutch (19s), press the old ones out of the pinion housing (19n).
2. Remove the small ring (19e) from the hub (19f). Remove the snap ring (19k) from the bearing recess of the housing (19n).

### KEY

- A Round steel bar to push on shaft (19b)
- B Hydraulic press
- C Steel bar stock
- D Two steel blocks
- E Press platform

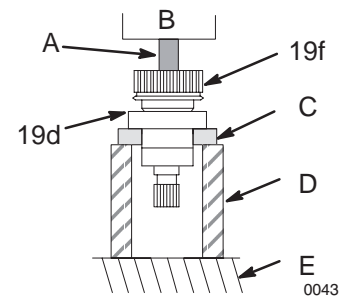

Fig. 15

0043

3. Push on the front of the shaft (19b) to force the bearing and hub assembly out of the housing (19n).
4. **Using a hydraulic press**, place pieces of steel bar stock on the inner race of the large bearing (19d) and press the shaft through the hub and bearing. See Fig. 15.
5. Apply lubricant to the parts as shown in Fig. 14.
6. Press fit the following parts:
  - Small bearing (19c) and then the roller clutch (19s), with the directional arrow facing the small bearing, into the rear of the housing (19n). See Detail A in Fig. 14.
  - Large bearing (19d) to shoulder of shaft (19b).
  - Hub (19f) onto the shaft (19b) all the way to the large bearing (19d).
7. Install the shaft assembly (19a), pushing it to the shoulder of the housing (19n).
8. Install the rings (19e and 19k).
9. Skip ahead to **Reassembly**, page 27, Step 7, or continue on page 22.



# Clutch

**NOTE:** The clutch assembly (4) includes the armature (4a) and rotor (4b). The armature and rotor must be replaced together so they wear evenly.

**NOTE:** If the pinion assembly (19) is not yet separated from the clutch housing, follow Steps 1 to 4. Otherwise, start at Step 5.

1. Follow the **Pressure Relief Procedure Warning** on page 12.
2. Disconnect the hose (55) from the displacement pump. **For the upright carts only**, detach the drain hose (91) from the pump.

3. Remove the bottom two screws (10) from the clutch housing (2) and then the top three screws.
4. Tap lightly on the back of the bearing housing (21) with a plastic mallet to loosen the assembly (D) from the clutch housing (2). Pull the assembly away; the armature (4a) will come with it. Remove the armature from the pinion shaft.
5. Remove the four capscrews (16). Install two of the screws in the threaded holes in the rotor (4b). Alternately tighten the screws until the rotor comes off. See Fig. 16.
6. Skip ahead to **Reassembly**, page 26, Step 6, or continue on the next page.

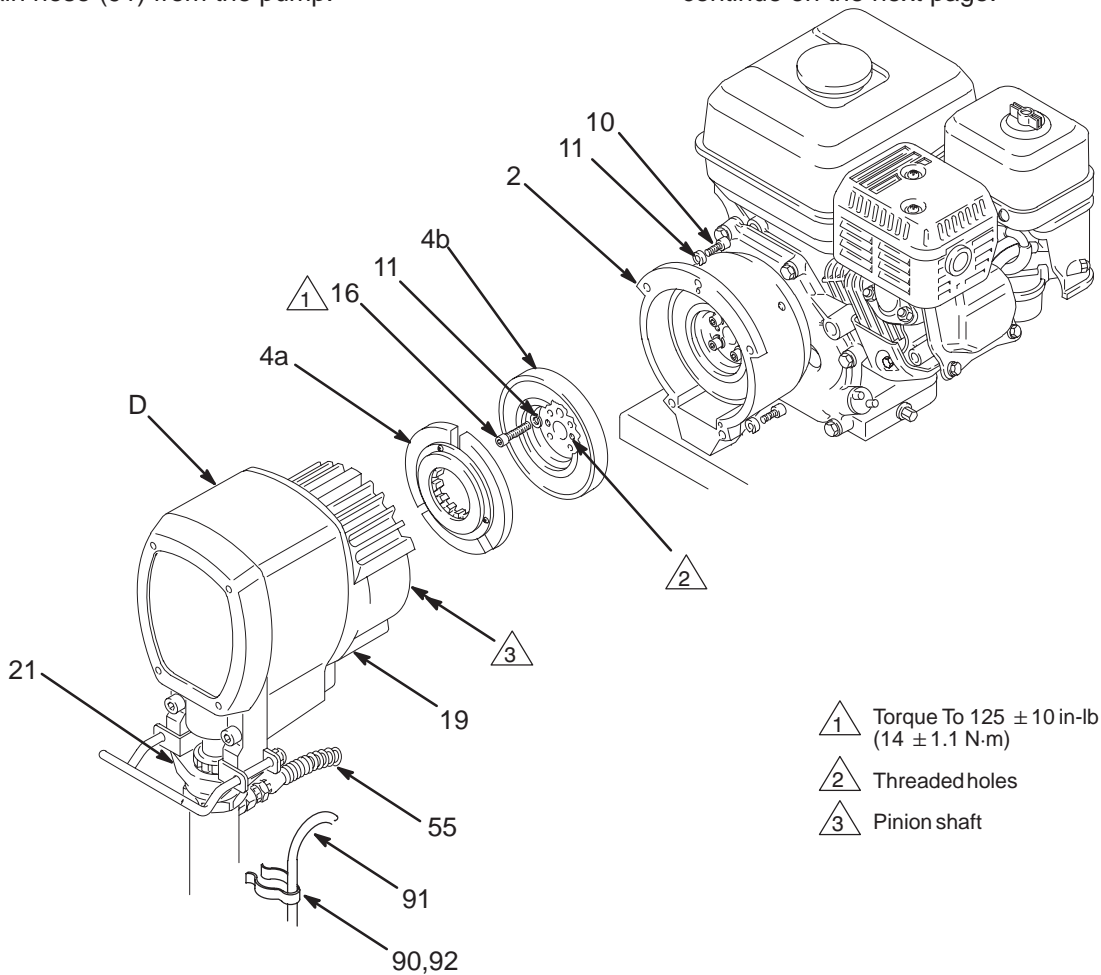

- 1 Torque To 125 ± 10 in-lb (14 ± 1.1 N·m)
- 2 Threaded holes
- 3 Pinion shaft

Fig. 16

0157A





# Field & Wiring Harness

**NOTE:** Refer to Fig. 19.

1. Remove the engine from the cart. See page 23.
2. Loosen the four setscrews (12) holding the field (6) to the clutch housing (2), and pull out the field.
3. Pull the plastic caps (B) off the wire screws (33) in both places on the field. Loosen the screws and release the wires (29).
4. Pull off the field.
5. Skip ahead to **Reassembly**, page 26, Step 4.

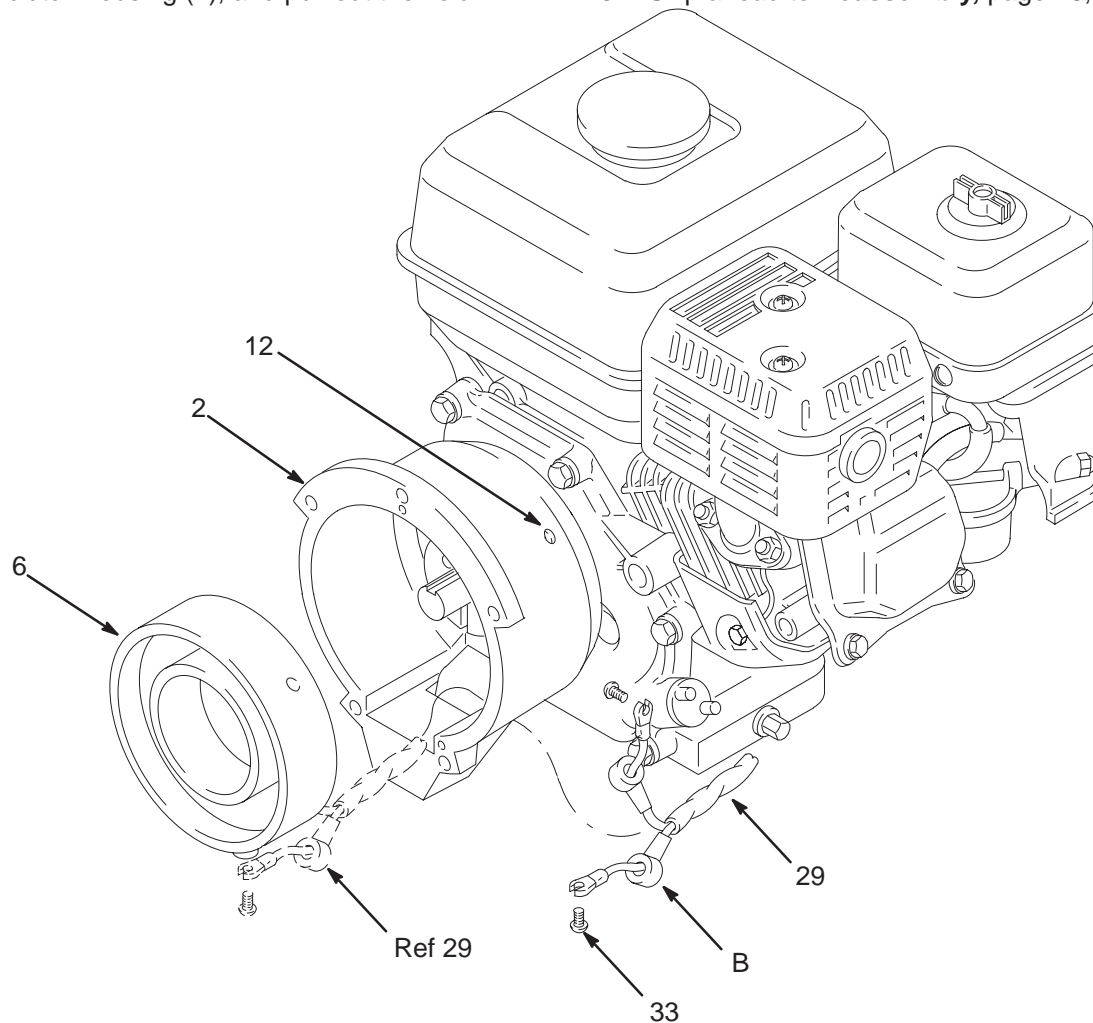

Fig. 19

03479

# Clamp

**NOTE:** A standard steering wheel puller is required to remove the clamp. Two 1/4–28 x 3 or 4 in. long screws are also needed.

**NOTE:** Refer to Fig. 20.

1. Loosen the two screws (16) on the clamp (3), working through the slot at the bottom of the clutch housing (2).
2. Install two screws (B) of the tool (A) in two of the threaded holes in the clamp. Tighten the screw (C) until the clamp comes off.
3. Skip ahead to **Reassembly**, page 26, Step 3, or continue to the right.

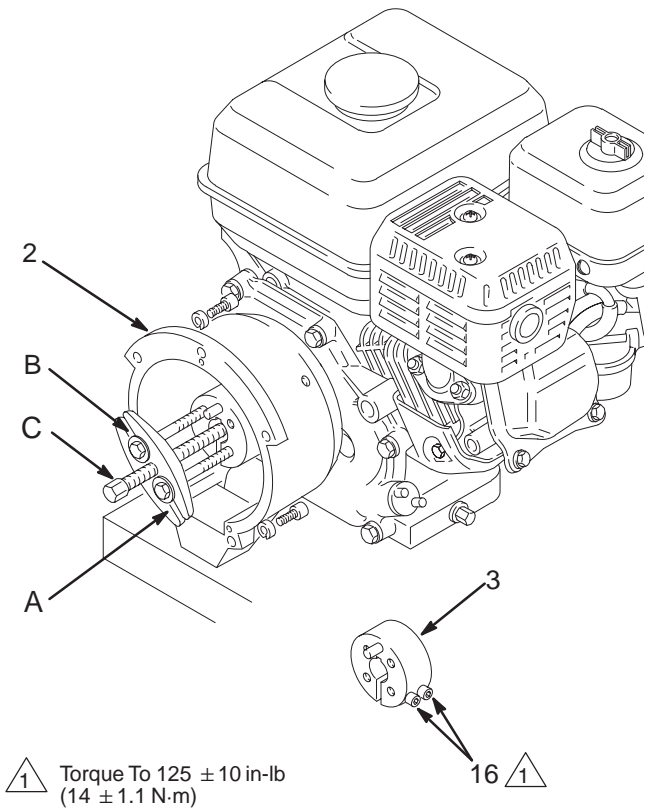

Fig. 20

0348C

# Clutch Housing

**NOTE:** Refer to Fig. 21.

1. Remove the four capscrews (8) and lockwashers (9) which hold the clutch housing (2) to the engine (1).
2. Remove the engine key (13).
3. Pull off the clutch housing (2).
4. Skip ahead to **Reassembly**, page 26, Step 1, or continue on page 30.

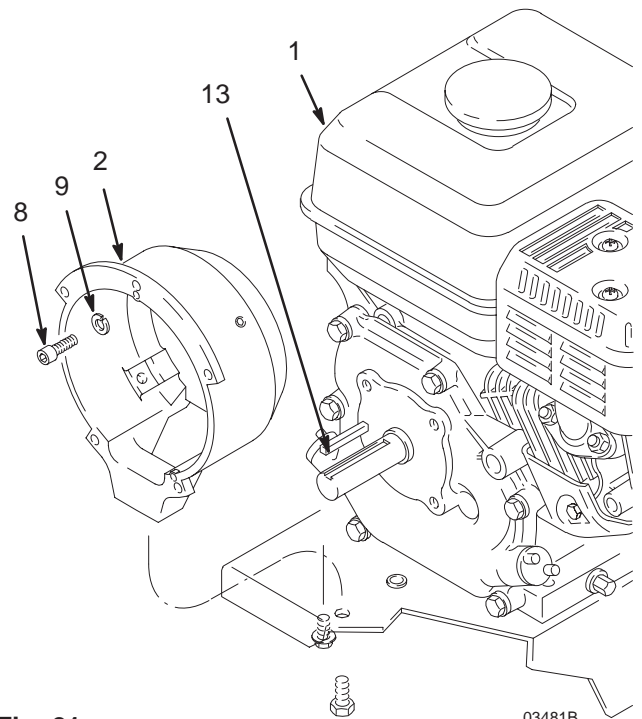

Fig. 21

03481B

# Reassembly

1. Install the **clutch housing (2)**, capscrews (8) and lockwashers (9) on the engine. Torque the capscrews (8) to  $200 \pm 10$  in-lb ( $23 \pm 1.1$  N·m). See Fig. 22.
2. Install the engine shaft **key (13)**. See Fig. 22.
3. Press the **clamp (3)** onto the engine shaft. Maintain the  $1.41 \pm 0.01$  in. ( $35.8 \pm 0.254$  mm) dimension shown in Fig. 23.
4. To check the dimension, place a rigid, straight steel bar (B) across the face of the clutch housing (2). Use an accurate measuring device to measure the distance between the bar and the face of the clamp. Torque the two screws (16) to  $125 \pm 10$  in-lb ( $14 \pm 1.1$  N·m).
5. Connect the wires of the harness (29) to the screws (33) in both places on the field. Pull the plastic caps (C) up and snap them over the screws. Guide the wires of the harness (29) through the slot in the clutch housing. Slide the **field (6)** into the clutch. Align the setscrew holes in the field and the clutch housing (2). Tighten the setscrews (12) oppositely and evenly, to  $27 \pm 3$  in-lb ( $3 \pm .33$  N·m). See Fig. 22.
6. Place the **engine (1)** assembly on the cart. Align the mounting holes. Guide the engine wire (B) and wiring harness (29) from the field through the appropriate grommets (62) in the mounting plate (E). Install the serrated flange screws (14), and nuts (48 or 57) and torque to  $15 \pm 2$  ft-lb ( $20 \pm 2.7$  N·m). Install the capscrew (15), from under the engine mounting plate to secure the clutch housing (2). Connect the engine wire (B) to the red wire (D), and connect the black and white wires as shown in Fig. 18.

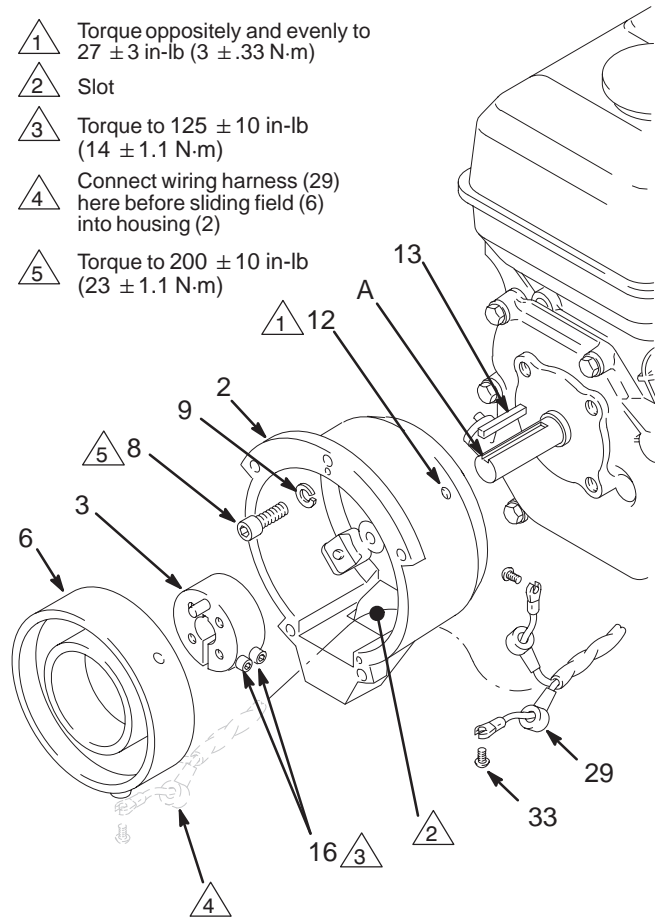

Fig. 22

0049A

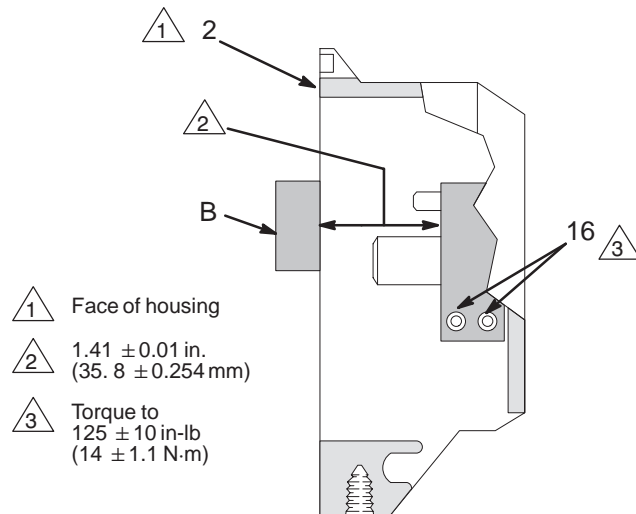

Fig. 23

Side cutaway view of clutch housing 0501

# Reassembly

- Be sure the face of the **rotor (4b)** and the field are free of all oil and contaminants. Remove any burrs on the outside edge of the rotor. Install the rotor, lockwashers (11) and capscrews (16). Torque the capscrews to  $125 \pm 10$  in-lb ( $14 \pm 1.1$  N·m). See Fig. 24.

After installing the **rotor (4b)**, check the clearance between the outside diameter of the rotor and the inside diameter of the field. The clearance must be at least 0.010 in. (0.25 mm) all the way around. Use shim stock or feeler gauge. If necessary, loosen the setscrews (12) and reposition the field. Tighten the setscrews evenly to  $27 \pm 3$  in-lb ( $3 \pm 0.33$  N·m).

- Pull the engine recoil rope to assure the engine turns freely, and there is no friction between the rotor (4b) and the field (6). If there is friction, loosen the setscrews (12) and reposition the field as necessary. Tighten the setscrews oppositely and evenly to  $27 \pm 3$  in-lb ( $3 \pm 0.33$  N·m). Also make sure there are no burrs on the outside edge of the rotor.

**NOTE:** With the autogap style armature, the gap between the rotor and the armature is critical for proper operation. The clutch kits with an autogap style armature include a cardboard spacer (186–857) to set the proper gap. This spacer is for use **only** during installation.

- Clean the face of the **armature (4a)**. With the flat side of the armature facing the rotor (4b), slide the armature onto the hub (F) in the drive/pinion assembly just until the chamfered end of the hub (19f) protrudes through the armature. See Detail B, Fig. 24. There will be significant resistance. Attach the cardboard spacer, supplied with the clutch kit, to the face of the armature. Engage the tabs on the spacer with the slots in the armature.

Brace the cart against a wall to keep it from rolling. Push the drive/pinion assembly onto the clutch housing (2). There will be significant resistance. When the mating surfaces of the drive/pinion assembly and the clutch housing (2) are flush, remove the drive/pinion assembly. **Remove the cardboard spacer.**

- Assemble the **pinion housing (19)** to the clutch housing (2), using the capscrews (10) and lockwashers (11). See Fig. 24.

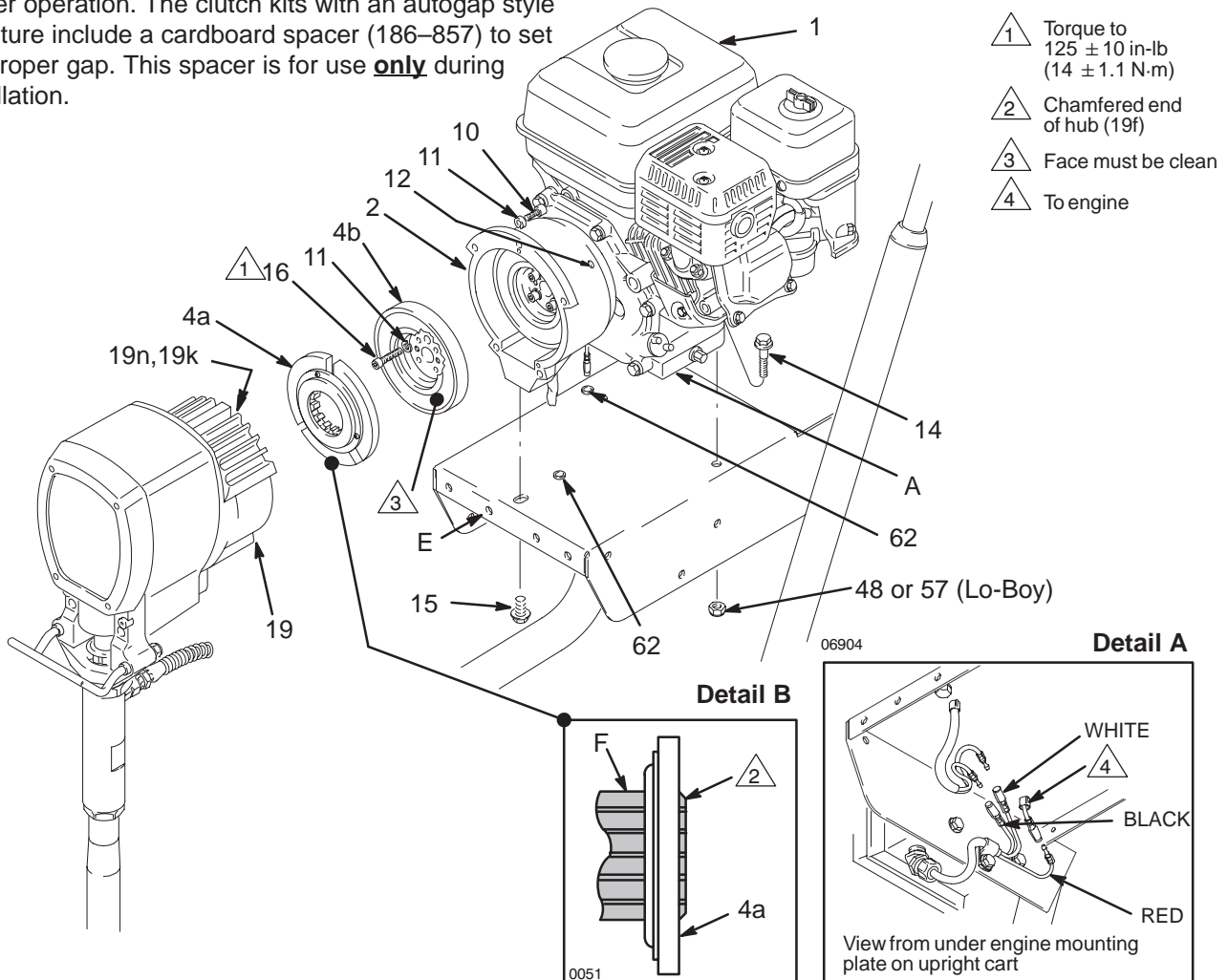
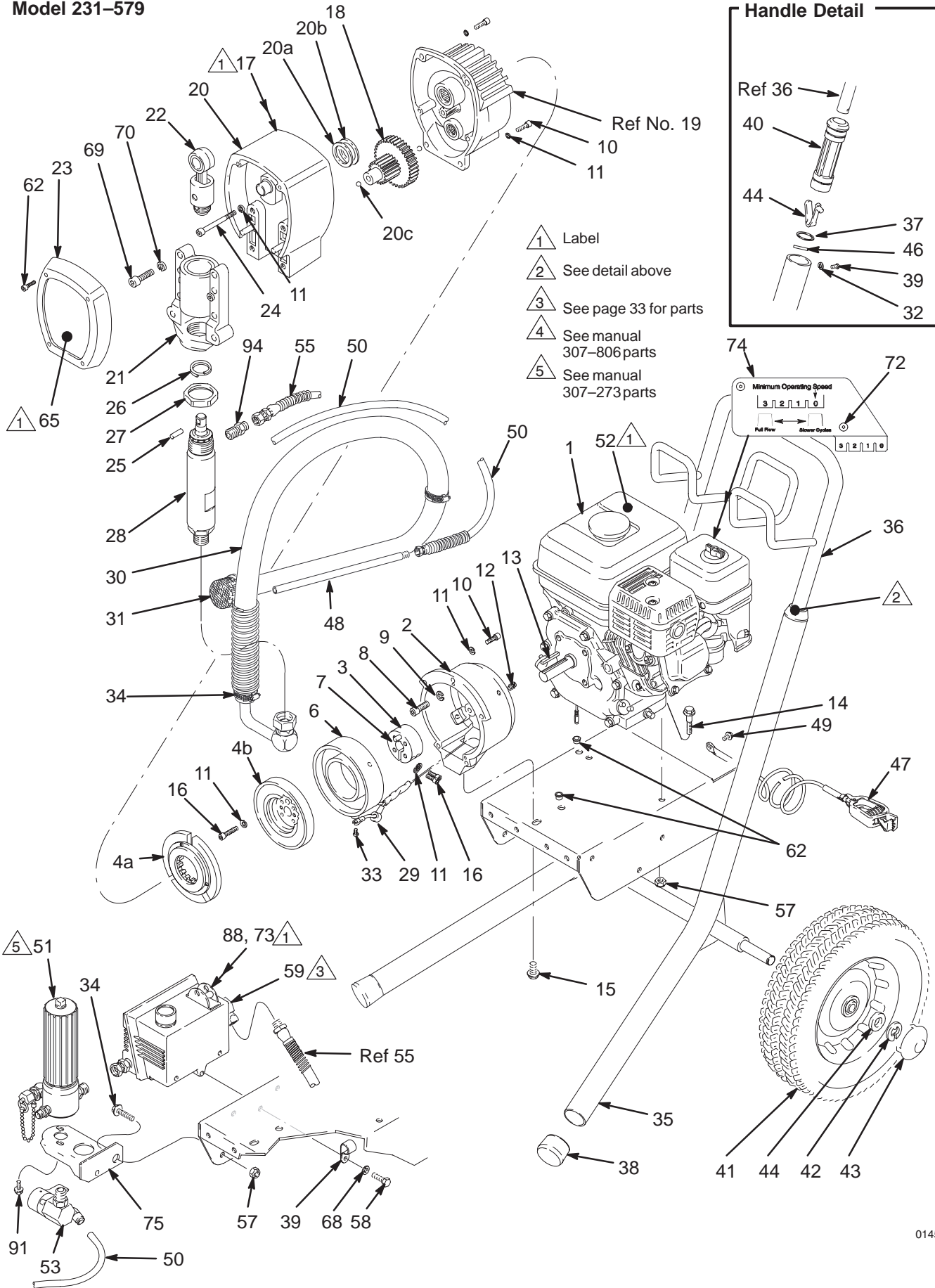

Fig. 24

# Parts – Basic Lo-Boy Cart

Model 231-579



01450C



# Parts – Basic Lo-Boy Sprayer

## Model 231–579

Ref No.	Part No.	Description	Qty	Ref No.	Part No.	Description	Qty
1	108–879	ENGINE, gasoline	1	36	238–187	CART HANDLE & HOSE RACK	1
2	183–512	HOUSING, clutch	1	37	183–350	WASHER, plain, 0.90 in.	2
3	183–517	CLAMP, mounting, rotor	1	38	108–691	PLUG, tubing	2
4	221–044	CLUTCH ASSEMBLY		39	108–868	CLAMP	1
		Includes items 4a and 4b	1	40	192–027	SLEEVE	2
4a		.ARMATURE	1	41	106–062	WHEEL, semi-pneumatic	2
4b		.ROTOR	1	42	101–242	RING, retaining	2
6	185–529	FIELD	1	43	104–811	HUBCAP	2
7	108–800	PIN, dowel, 5/16 x 1 in.	1	44	112–827	BUTTON, snap	2
8	109–031	CAPSCREW, 1/2 sch, 5/16–24 x 1 in.	4	45	109–032	SCREW, recess pnh, self-tap "F", No. 10–24 x 1/4 in.	4
9	104–008	LOCKWASHER, 5/16 in.	4	47	237–686	GROUNDING CLAMP & WIRE	1
10	100–644	CAPSCREW, sch, 1/4–20 x 3/4 in.	9	48	192–013	TUBE, drain	1
11	105–510	LOCKWASHER, spring, 1/4 in.	17	49	112–798	SCREW, hex hd, thread frmng 1/4–20 x 3/8 in.	1
12	108–801	SETSCREW, 1/4 in.	4	50	190–963	HOSE, drain	1
13	183–401	KEY, parallel, 3/16 in. sq x 7/8 in.	1	51	239–286	FLUID FILTER	
14	110–837	SCREW, serrated flange, hex hd, 5/16–18 x 1–1/2 in.	2			See 307–273 for parts	1
15	113–802	SCREW, serrated flange, hex hd, 3/8–16 x 5/8 in.	1	52▲	181–867	LABEL, WARNING <i>on engine</i>	1
16	108–803	CAPSCREW, hex sch, 1/4–28 x 1.0 in.	6	53	239–267	VALVE, pressure drain	1
17▲	185–953	LABEL, DANGER <i>on drive housing</i>	1	55	222–516	HOSE, 3/8 in. ID, 29 in. (715 mm), cpld 3/8–18 npt(m) x 3/8 npsm(f) swivel; spring guard both ends	1
18	221–042	GEAR REDUCER	1	57	110–838	LOCKNUT, heavy hex, 5/16–18	3
19	223–188	PINION		58	101–344	CAPSCREW, hex hd, 5/16–18 UNC–2a x 5/8 in.	3
		See parts on page 32	1	59	239–266	PRESSURE CONTROL ASSEMBLY	
20	218–032	DRIVE HOUSING KIT				See page 36 for parts	1
		Includes items 20a to 20d	1	62	109–099	BUSHING, snap	2
20a	178–967	.WASHER, bronze	1	64	107–209	SCREW, filh, 8–32 x 1 in.	4
20b	107–089	.WASHER, silver	1	65	290–365	LABEL, identification	1
20c	100–069	.BALL, sst	1	68	100–214	LOCKWASHER, spring, 5/16 in.	3
20d	110–293	.GREASE	1	69	107–210	CAPSCREW, sch, 3/8–16 x 1–1/2 in.	4
21	218–035	BEARING HOUSING	1	70	106–115	LOCKWASHER, spring, 3/8 in.	4
22	218–034	CONNECTING ROD	1	72	113–084	RIVET, blind	2
23	179–899	COVER, housing	1	73	290–375	LABEL, identification, control, top	1
24	107–218	CAPSCREW, sch, 1/4–20 x 2.75 in.	2	74	192–014	PLATE, indicator	1
25	176–818	PIN	1	75	237–831	BRACKET, mounting, filter	1
26	176–817	SPRING, retaining	1	82	206–994	THROAT SEAL LIQUID, 8 oz (0.27 liter) <i>not shown</i>	1
27	178–941	NUT, hex	1	88	290–366	LABEL, identification, control, bottom	1
28	222–580	DISPLACEMENT PUMP		91	110–997	SCREW, serrated flange, hex hd, 1/4–20 x 5/8 in.	2
		See manual 307–806 for parts		94	183–461	NIPPLE, 3/8–18 npsm(m) x 1/4–18 npt(m) x 1–5/16 in. long	1
		See ACCESSORIES for repair kit	1				
29	221–183	CONDUCTOR, electrical	1				
30	239–059	TUBE, suction	1				
31	181–072	STRAINER	1				
32	100–020	LOCKWASHER, spring	4				
33	109–033	SCREW, slotted, 6–32 x 3/16 in.	2				
34	112–818	CAPSCREW, hex hd, flanged, 5/16–18 x 3/4 in.	1				
35	238–685	CART	1				

▲ Replacement Danger and Warning labels, tags and cards are available at no cost.



# Parts – Basic Upright Sprayer

Model 231-578

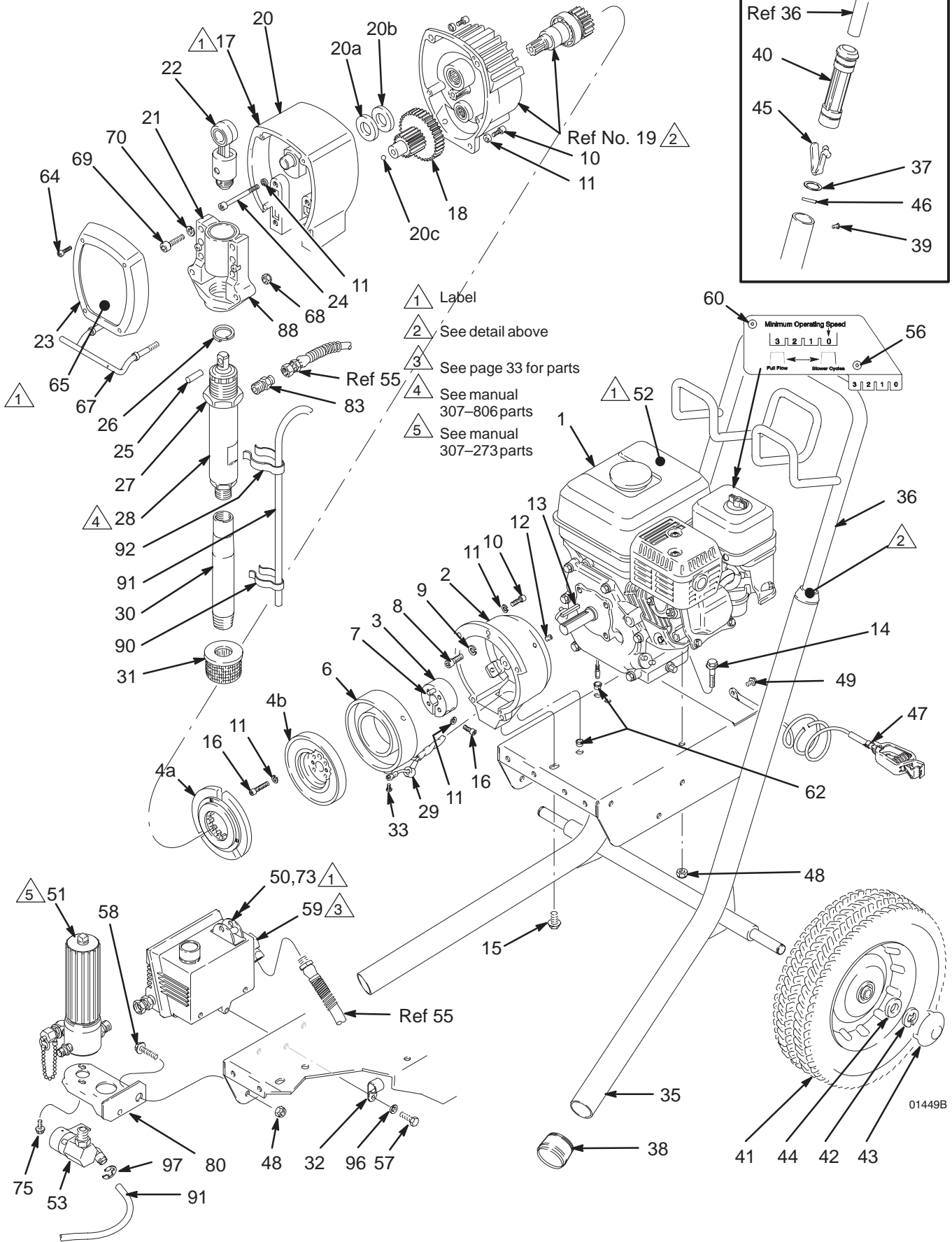

# Parts – Basic Upright Sprayer

## Model 231–578

Ref No.	Part No.	Description	Qty	Ref No.	Part No.	Description	Qty
1	108–879	ENGINE, gasoline	1	40	192–027	SLEEVE	2
2	183–512	HOUSING, clutch	1	41	106–062	WHEEL, semi–pneumatic	2
3	183–517	CLAMP, mounting, rotor	1	42	101–242	RING, retaining	2
4	221–044	CLUTCH ASSEMBLY		43	104–811	HUBCAP	2
		Includes items 4a and 4b	1	44	100–020	LOCKWASHER, spring, 3/16 in.	4
4a		.ARMATURE	1	45	112–827	BUTTON, snap	2
4b		.ROTOR	1	46	108–068	PIN, spring, straight, 3/16 in.	2
6	185–529	FIELD	1	47	237–686	GROUNDING CLAMP & WIRE	1
7	108–800	PIN, dowel, 5/16 x 1 in.	1	48	110–838	NUT, heavy hex, 5/16–18 UNC–2a	3
8	109–031	CAPSCREW, 1/2 sch, 5/16–24 x 1 in.	4	49	112–798	SCREW, hex hd, thread frmg	
9	104–008	LOCKWASHER, 5/16 in.	4			1/4–20 x 3/8 in.	1
10	100–644	CAPSCREW, sch, 1/4–20 x 3/4 in.	9	50	290–366	LABEL, identification, control, bottom	1
11	105–510	LOCKWASHER, spring, 1/4 in.	17	51	239–286	FLUID FILTER	
12	108–801	SETSCREW, 1/4 in.	4			See 307–273 for parts	1
13	183–401	KEY, parallel, 3/16 in. sq x 7/8 in.	1	52▲	181–867	LABEL, WARNING <i>on engine</i>	1
14	110–837	SCREW, serrated flange, hex hd, 5/16–18 unc–2a x 1.5 in.	2	53	237–677	VALVE, pressure drain	1
15	113–802	SCREW, serrated flange, hex hd, 3/8–16 x 5/8 in.	1	55	222–516	HOSE, 3/8 in. ID, 29 in. (715 mm), cpld 3/8–18 npt(m) x 3/8 npsm(f) swivel; spring guard both ends	1
16	108–803	CAPSCREW, hex sch, 1/4–28 x 1.0 in.	6	56	113–084	RIVET, blind	2
17▲	185–953	LABEL, DANGER <i>on drive housing</i>	1	57	101–344	CAPSCREW, hex hd, 5/16–18 UNC–2a x 5/8 in.	3
18	221–042	GEAR REDUCER	1			5/16–18 x 3/4 in.	1
19	223–188	PINION		58	112–818	CAPSCREW, hex hd, flanged, 5/16–18 x 3/4 in.	1
		See parts on page 32	1			PRESSURE CONTROL ASSEMBLY	
20	218–032	DRIVE HOUSING		59	239–266	See page 36 for parts	1
		Includes items 20a to 20d	1	60	192–014	PLATE, indicator	1
20a	178–967	.WASHER, bronze	1	62	109–099	BUSHING, snap	2
20b	107–089	.WASHER, silver	1	64	107–209	SCREW, filh, 8–32 UNC–2a x 1 in.	4
20c	100–069	.BALL, sst	1			LABEL, identification	1
20d	110–293	.GREASE	1	65	290–365	HANGER, pail	1
21	218–035	BEARING HOUSING	1	67	189–918	NUT, retainer	2
22	218–034	CONNECTING ROD	1	68	112–746	CAPSCREW, sch, 3/8–16 x 1–1/2 in.	4
23	179–899	COVER, housing	1	69	107–210	LOCKWASHER, spring, 3/8 in.	4
24	107–218	CAPSCREW, sch, 1/4–20 x 2–3/4 in.	2	70	106–115	LABEL, identification, control, top	1
25	176–818	PIN	1	73	290–375	SCREW, serrated flange, hex hd, 1/4–20 x 5/8 in.	2
26	176–817	SPRING, retaining	1	75	110–997	BRACKET, mounting, filter	1
27	178–941	NUT, hex	1	80	237–831	THROAT SEAL LIQUID, 8 oz (0.27 liter) <i>not shown</i>	1
28	222–580	DISPLACEMENT PUMP		82	206–994	NIPPLE, 3/8–18 npsm(m) x 1/4–18 npt(m) x 1–5/16 in. long	1
		See manual 307–806 for parts	1			CLIP, spring	1
29	221–183	CONDUCTOR, electrical	1	90	181–102	TUBE, bypass	1
30	180–573	TUBE, suction, 5 gal, 3/4 in. pipe	1	91	191–889	CLIP, spring	1
31	181–072	STRAINER	1	92	186–494	LOCKWASHER, spring, 5/16 in.	3
32	108–868	CLAMP	1	96	100–214	RING, retaining	1
33	109–033	SCREW, slotted, 6–32 x 3/16 in.	2	97	113–983		
35	239–422	CART	1				
36	238–187	HANDLE & HOSE RACK	1				
37	183–350	WASHER, plain, 0.90 in.	2				
38	108–691	PLUG, tubing	2				
39	109–032	SCREW, recess pnh, self–tap “F”, No. 10–24 x 1/4 in.	4				

▲ Replacement Danger and Warning labels, tags and cards are available at no cost.

# Parts – Complete Sprayers

## Model 231–057

### Sprayer with Upright Cart

Includes items 120 to 123

## Model 231–077

### Sprayer with Lo–Boy Cart

Includes items 121 to 124

Ref No.	Part No.	Description	Qty
120	231–578	GM3500 Basic Upright Sprayer See parts list on page 31	1
121	223–541	HOSE, grounded, nylon, 1/4 in. ID, cpld 1/4 npsm(f), 50 ft (15 m), spring guards both ends	1
122	214–701	HOSE, grounded, nylon, 3/16 in. ID, cpld 1/4 npsm(f), 3 ft (0.9 m), spring guards both ends	1
123	220–955	CONTRACTOR SPRAY GUN Includes RAC IV® DripLess™ Tip Guard and 517–size SwitchTip™ See 307–614 for parts	1
124	231–579	GM3500 Basic Lo–Boy Sprayer See parts list on page 29	1

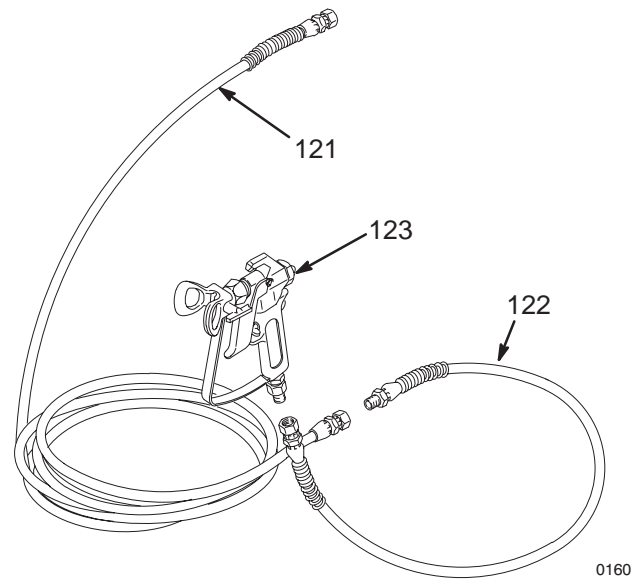

# Parts – Pinion Assembly

## Ref No. 19

### Pinion Housing

Includes items 19a to 19f and 19s

Ref No.	Part No.	Description	Qty	Ref No.	Part No.	Description	Qty
19a	223–189	PINION SHAFT ASSEMBLY Includes items 19b to 19f and 19s	1	<b>NOTE:</b> Items 19g to 19n are not included in a kit. Order them separately as needed.			
19b	183–681	.SHAFT, pinion	1	19g	105–684	BEARING, ball, large	1
19c	109–001	.BEARING, needle	1	19h	107–088	BEARING, ball, small	1
19d	109–002	.BEARING, ball	1	19j	100–069	BALL, sst	1
19e	108–880	.RING, retaining, external	1	19k	109–000	RING, retaining, internal	1
19f	183–515	.HUB, armature	1	19m	105–489	PIN, dowel	2
19s	110–607	CLUTCH, roller	1	19n	185–491	HOUSING, pinion	1

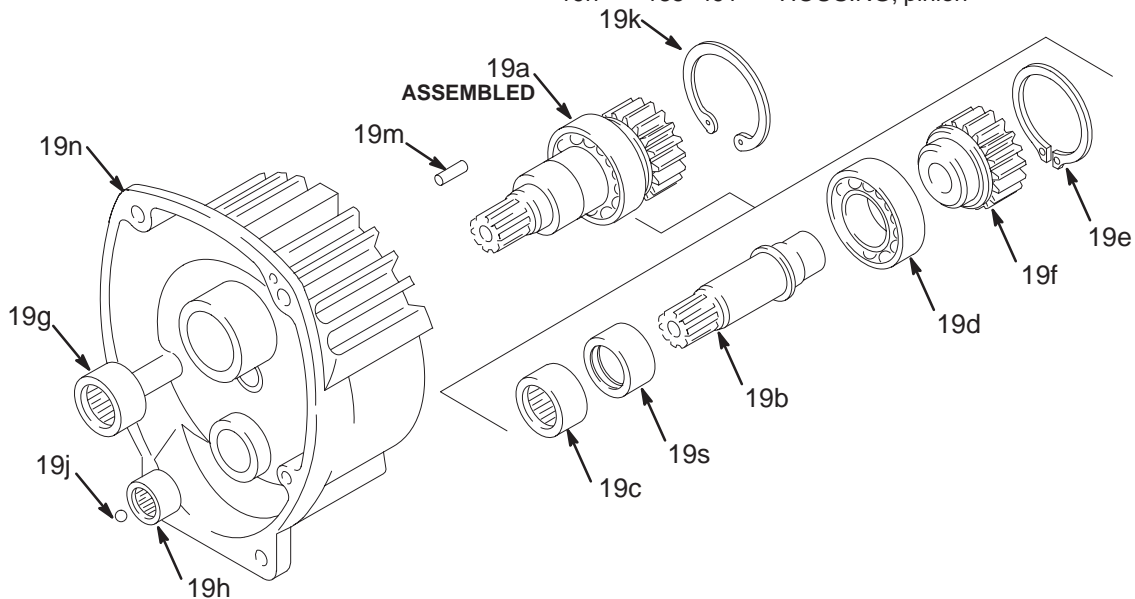

# Parts List – Pressure Control

## Basic Pressure Control for the GM3500 Sprayers

Ref No.	Part No.	Description	Qty	Ref No.	Part No.	Description	Qty
301	239-056	ENGINE CONTROL BOARD	1	312	112-373	KNOB	1
302	107-251	SCREW, panhead, 10-24 x 1 inch	2	313	185-565	LABEL	1
303	112-610	SCREW, panhead, 10-24 x 2 inch	2	314	237-674	CONDUCTOR	1
304	100-020	LOCKWASHER, No. 10	4	315	109-078	CONNECTOR	1
305	189-095	HOUSING,	1	316	112-376	LOCKNUT	1
306	112-614	PLUG	1	317	100-078	SCREW, hex head, 8-24 x .375 inch	1
307	105-679	TOGGLE SWITCH	1	318▲	189-286	LABEL, warning	1
308	107-255	GUARD	1	319▲	189-246	LABEL, warning	1
309	105-659	BOOT	1				
310	236-352	POTENTIOMETER, pressure adjustment	1				
311	112-382	NUT, shaft, sealing	1				

▲ Replacement Danger and Warning labels, tags, and cards are available free.

## Parts Drawing – Pressure Control

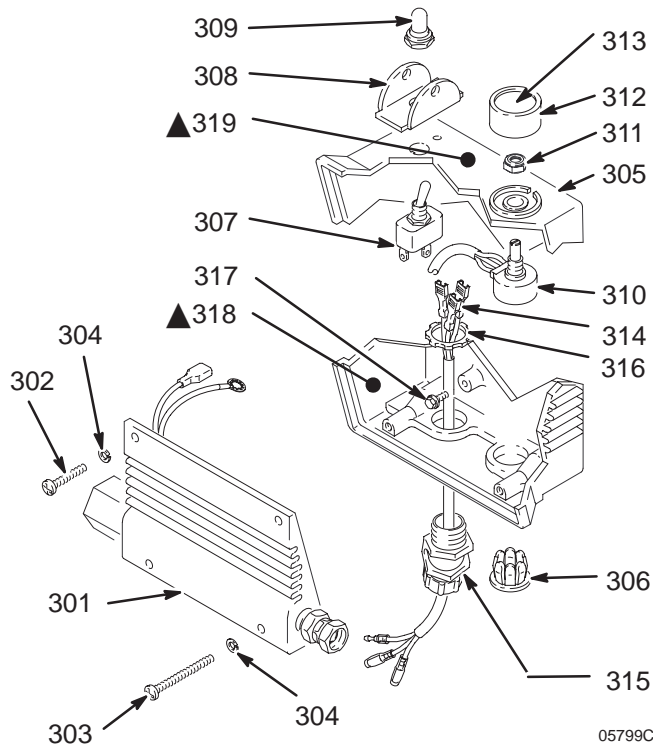

05799C

## Wiring Schematic – Pressure Control

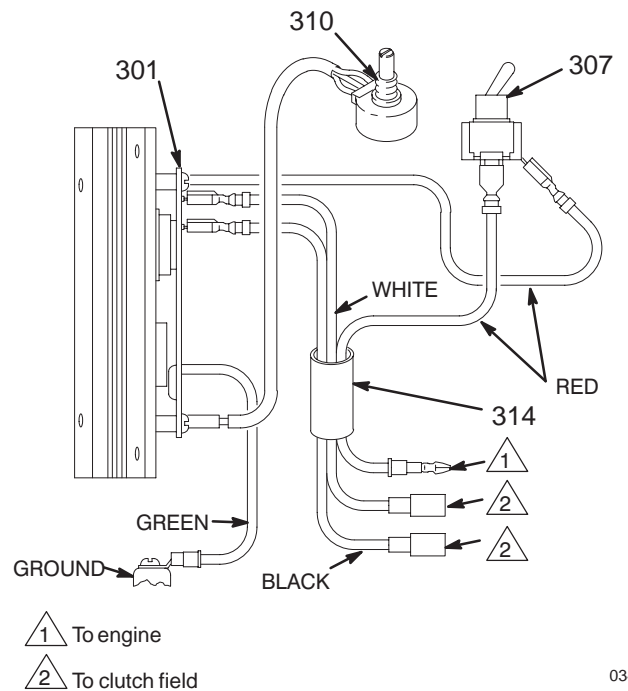

03496

# Accessories

## USE ONLY GENUINE GRACO PARTS AND ACCESSORIES

### DANGER LABELS

The English language DANGER label shown on page 1 is also on your sprayer. If you have painters who do not read English, order one of the following labels to apply to your sprayer. The drawing below shows the best placement of these labels for good visibility.

Order the labels directly from Graco, free of charge. Toll Free: 1-800-328-0211

<b>French</b>	<b>185-956</b>
<b>Spanish</b>	<b>185-961</b>
<b>German</b>	<b>186-041</b>
<b>Greek</b>	<b>186-045</b>
<b>Korean</b>	<b>186-049</b>
<b>English</b>	<b>185-953</b>

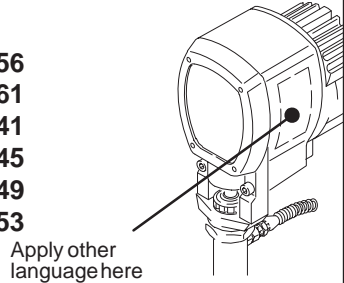

0505

### SUCTION TUBE KIT 208-259

55 gallon (200 liter) size, For Upright Cart Sprayers  
Includes:

Ref No.	Part No.	Description	Qty
1	156-589	UNION, 90° ADAPTER, 3/4 npt(f) x 3/4 np(f) swivel	1
2	214-961	HOSE, coupled 3/4 npt(mbe) 3/4 in. ID; nylon, 6 ft (1.8 m); spring guard one end	1
3	156-591	ELBOW, 90°; 3/4 npt x 1-1/2 - 24 NS	1
4	156-593	PACKING, o-ring, nitrile rubber	1
5	100-220	THUMBSCREW, 5/16-18 x 1 in.	1
6	176-684	ADAPTER, bung	1
7	156-592	TUBE, riser	1
8	159-100	RETAINER, screen	1
9	161-377	SCREEN, filter	1
10	159-101	NUT, screen retainer	1

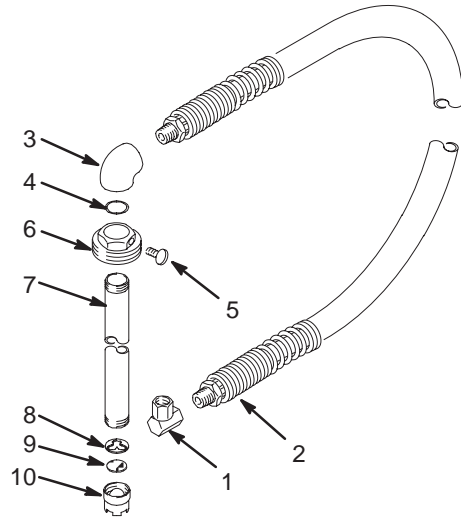

0161

### DISPLACEMENT PUMP REPAIR KIT 222-588

See contents in manual 307-806. Repair instructions are included with the kit.

### SLEEVE REMOVAL TOOL 222-586

Required for removing the sleeve of the displacement pump during service.

### THROAT SEAL LIQUID

Non-evaporating liquid for the wet-cup. Helps prevent buildup of paint on the rod and throat packings, to reduce premature wear.

<b>206-994</b>	8 oz.
<b>206-995</b>	1 quart
<b>206-996</b>	1 gallon

### SUCTION TUBE KIT 208-920

5 gallon (19 liter) size, For Upright Cart Sprayers  
Includes:

Ref No.	Part No.	Description	Qty
1	101-818	CLAMP, hose	2
2	160-327	UNION, 90° swivel; 3/4 npt(m x f)	1
3	170-705	ADAPTER, intake	1
4	170-706	HOSE, 1 in. ID x 48 in.; nylon	1
5	170-957	TUBE, suction	1
6	181-072	STRAINER	1

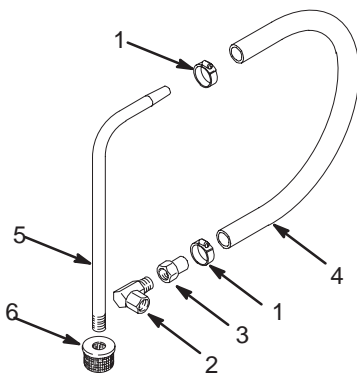

0161

# Technical Data

Engine ..... 4.0 Horsepower, Honda  
Maximum Working Pressure ..... 3000 psi  
(210 bar, 21 MPa)  
Noise Level  
Sound Power ..... 103 dbA  
Sound Pressure ..... 95 dbA @ 1 meter under  
maximum operating conditions  
per ISO-3744  
Cycles/Gallon (liter) ..... 200 (53)  
Maximum Delivery ..... 0.85 gpm (3.2 liter/min)  
Fuel Tank Capacity ..... 0.66 gallons (2.5 liter)  
Maximum Tip Size ..... 1 gun with 0.031 tip  
2 guns with 0.021 tip

Inlet Paint Strainer ..... 16 mesh (1190 micron)  
Stainless Steel screen, reusable  
Outlet Paint Filter ..... 60 mesh (250 micron)  
Stainless Steel screen, reusable  
Pump inlet Size ..... 3/4 npt (m)  
Fluid Outlet Size ..... 1/4 npsm from fluid filter  
Wetted Parts  
*Displacement Pump* . Carbon Steel, Plastic, Leather  
*Filter* ..... Aluminum, Carbon Steel, Stainless Steel

**NOTE:** For information on converting your sprayer to one that can safely pump fluids containing halogenated hydrocarbons, contact Graco Product Service, at 1-800-328-0211.

## Dimensions

### Model 231-578

#### Upright Cart without hose or gun

Weight (dry, without packaging) ..... 109 lb (49 kg)  
Height ..... 30.25 in. (768 mm)  
Length ..... 29.5 in. (749 mm)  
Width ..... 22.25 in. (565 mm)

### Model 231-579

#### Lo-Boy Cart without hose or gun

Weight (dry, without packaging) ..... 109 lb (49 kg)  
Height ..... 30.25 in. (768 mm)  
Length ..... 29.5 in. (749 mm)  
Width ..... 22.25 in. (565 mm)

## Graco Phone Number

**TO PLACE AN ORDER,** contact your Graco distributor, or call this number to identify the distributor closest to you:  
**1-800-328-0211 Toll Free.**



# Graco Warranty

Graco warrants all equipment listed in this manual which is manufactured by Graco and bearing its name to be free from defects in material and workmanship on the date of sale by an authorized Graco distributor to the original purchaser for use. With the exception of any special extended or limited warranty published by Graco, Graco will, for a period of twelve months from the date of sale, repair or replace any part of the equipment determined by Graco to be defective. This warranty applies only when the equipment is installed, operated and maintained in accordance with Graco's written recommendations.

This warranty does not cover, and Graco shall not be liable for general wear and tear, or any malfunction, damage or wear caused by faulty installation, misapplication, abrasion, corrosion, inadequate or improper maintenance, negligence, accident, tampering, or substitution of non-Graco component parts. Nor shall Graco be liable for malfunction, damage or wear caused by the incompatibility of Graco equipment with structures, accessories, equipment or materials not supplied by Graco, or the improper design, manufacture, installation, operation or maintenance of structures, accessories, equipment or materials not supplied by Graco.

This warranty is conditioned upon the prepaid return of the equipment claimed to be defective to an authorized Graco distributor for verification of the claimed defect. If the claimed defect is verified, Graco will repair or replace free of charge any defective parts. The equipment will be returned to the original purchaser transportation prepaid. If inspection of the equipment does not disclose any defect in material or workmanship, repairs will be made at a reasonable charge, which charges may include the costs of parts, labor, and transportation.

Graco's sole obligation and buyer's sole remedy for any breach of warranty shall be as set forth above. The buyer agrees that no other remedy (including, but not limited to, incidental or consequential damages for lost profits, lost sales, injury to person or property, or any other incidental or consequential loss) shall be available. Any action for breach of warranty must be brought within two (2) years of the date of sale.

**GRACO MAKES NO WARRANTY, AND DISCLAIMS ALL IMPLIED WARRANTIES OF MERCHANTABILITY AND FITNESS FOR A PARTICULAR PURPOSE IN CONNECTION WITH ACCESSORIES, EQUIPMENT, MATERIALS OR COMPONENTS SOLD BUT NOT MANUFACTURED BY GRACO.** These items sold, but not manufactured by Graco (such as electric motors, gas engines, switches, hose, etc.), are subject to the warranty, if any, of their manufacturer. Graco will provide purchaser with reasonable assistance in making any claim for breach of these warranties.

In no event will Graco be liable for indirect, incidental, special or consequential damages resulting from Graco supplying equipment hereunder, or the furnishing, performance, or use of any products or other goods sold hereto, whether due to a breach of contract, breach of warranty, the negligence of Graco, or otherwise.

## **FOR GRACO CANADA CUSTOMERS**

The parties acknowledge that they have required that the present document, as well as all documents, notices and legal proceedings entered into, given or instituted pursuant hereto or relating directly or indirectly hereto, be drawn up in English. Les parties reconnaissent avoir convenu que la rédaction du présente document sera en Anglais, ainsi que tous documents, avis et procédures judiciaires exécutés, donnés ou intentés à la suite de ou en rapport, directement ou indirectement, avec les procédures concernées.

## **ADDITIONAL WARRANTY COVERAGE**

Graco does provide extended warranty and wear warranty for products described in the "Graco Contractor Equipment Warranty Program".

*All written and visual data contained in this document reflects the latest product information available at the time of publication.  
Graco reserves the right to make changes at any time without notice.*

**Sales Offices:** Minneapolis, Detroit, Los Angeles  
**Foreign Offices:** Belgium, Canada, England, Korea, France, Germany, Hong Kong, Japan

**GRACO INC. P.O. BOX 1441 MINNEAPOLIS, MN 55440-1441**

**<http://www.graco.com>**

©1998-1997 Graco Inc. 308-709 Rev. B May 1998 PRINTED IN U.S.A.