

INSTRUCTIONS—PARTS LIST



308572

Rev. P

This manual contains important warnings and information.
READ AND KEEP FOR REFERENCE.

INSTRUCTIONS

First choice when quality counts.™

Direct-Drive Pressure Washers

1535

Model 804506, Series A

1500 psi (102 bar, 10.2 MPa) Operating Pressure

1900 psi (131 bar, 13.1 MPa) Maximum Working Pressure

2030

Model 804532, Series A

2000 psi (138 bar, 13.8 MPa) Operating Pressure

2400 psi (165 bar, 16.5 MPa) Maximum Working Pressure

2540

Model 804507, Series A

2500 psi (172 bar, 17.2 MPa) Operating Pressure

2900 psi (200 bar, 20.0 MPa) Maximum Working Pressure

2835

Model 804583, Series A

2800 psi (193 bar, 19.3 MPa) Operating Pressure

3200 psi (221 bar, 22.1 MPa) Maximum Working Pressure

3040

Model 804508, Series A

3000 psi (210 bar, 21.0 MPa) Operating Pressure

3400 psi (234 bar, 23.4 MPa) Maximum Working Pressure

Related Manual

Hydra-Clean® Gun 308511

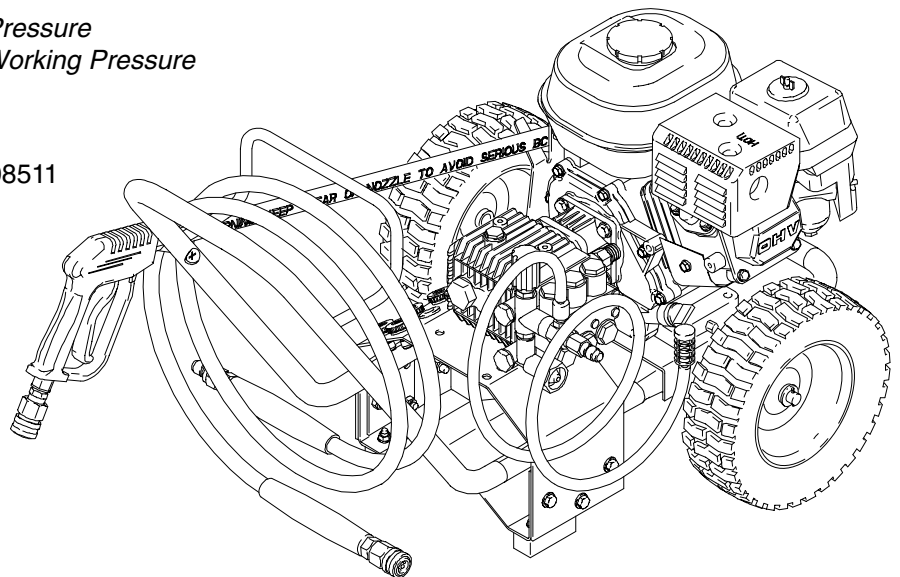

1535 Pressure Washer

Model 804506

7329B

GRACO INC. P.O. BOX 1441 MINNEAPOLIS, MN 55440-1441

©COPYRIGHT 1995 GRACO INC.

Graco Inc. is registered to I.S. EN ISO 9001

Table of Contents

| | |
|---|----|
| Warnings | 2 |
| Setup | 4 |
| Pressure Relief Procedure | 5 |
| Operation | 5 |
| Troubleshooting | 8 |
| Pump Service | |
| 1535 and 2030 Pressure Washers | 10 |
| 2540, 2835, and 3040 Pressure Washers | 12 |
| Parts Lists and Drawings | |
| 1535 and 2030 Pressure Washers | 14 |
| 2540 and 3040 Pressure Washers | 16 |
| 2835 Pressure Washer | 18 |
| Pump Assembly for 1535 and 2030 Pressure Washers | 20 |
| Pump Assembly for 2540, 2835, and 3040 Pressure Washers | 22 |
| Accessories | 25 |
| Technical Data | 25 |
| Graco Warranty | 26 |
| Graco Phone Number | 26 |

Warning Symbol



This symbol alerts you to the possibility of serious injury or death if you do not follow the instructions.

Caution Symbol



This symbol alerts you to the possibility of damage to or destruction of equipment if you do not follow the instructions.

WARNING

| | |
|--|---|
| | <p>INJECTION HAZARD</p> <p>Spray from the gun, leaks, or ruptured components can inject fluid into your body and cause serious injury. Fluid splashed in the eyes or on the skin can also cause serious injury.</p> <ul style="list-style-type: none"> ● Fluid injected into the skin might look like just a cut, but it is a serious injury. Get emergency medical attention. ● Do not point the gun at anyone or at any part of the body. ● Do not stop or deflect leaks with hand, body, glove, or rag. ● Do not put your hand or fingers over the spray tip. ● Tighten fluid connections before you start this equipment. ● Engage the gun trigger safety whenever you stop spraying. ● Follow Pressure Relief Procedure on page 5 if the spray tip clogs and before you clean, check, or service this equipment. ● Repair or replace worn or damaged parts immediately. ● Check hoses, tubes, and coupling daily. Do not repair high-pressure couplings. Replace the entire hose. Fluid hoses must have spring guards on both ends to prevent kinks and rupture. |
|--|---|

WARNING



HAZARDOUS FLUIDS

Improper handling of hazardous fluids can cause serious injury or death due to splashing in eyes, ingestion, or bodily contamination.

- Know the specific hazards of the fluid being used.
- Store hazardous fluids in approved containers. Dispose of hazardous fluids per local, state, and national guidelines.
- Wear protective eye wear, gloves, clothing, and respirator as recommended by the fluid manufacturer.



FUEL HAZARD

The fuel used in this pressure washer is combustible. When spilled on a hot surface, it can ignite and cause a fire.

Do not fill the fuel tank while the engine is running or hot.



EXHAUST HAZARD

The exhaust contains poisonous carbon monoxide, which is colorless and odorless.

Do not operate this equipment in a closed building.



EQUIPMENT MISUSE HAZARD

Misuse of the pressure washer or accessories could cause them to rupture and result in fluid injection, splashing in the eyes or on the skin, or other serious injury.

- Do not alter or modify any part or factory-set adjustment of this equipment.
- Do not exceed the maximum working pressure of any component or accessory in the system.
- Do not use any chemicals that are incompatible with the wetted parts as stated in **Technical Data** on page 25.
- Do not alter the throttle setting.

Setup

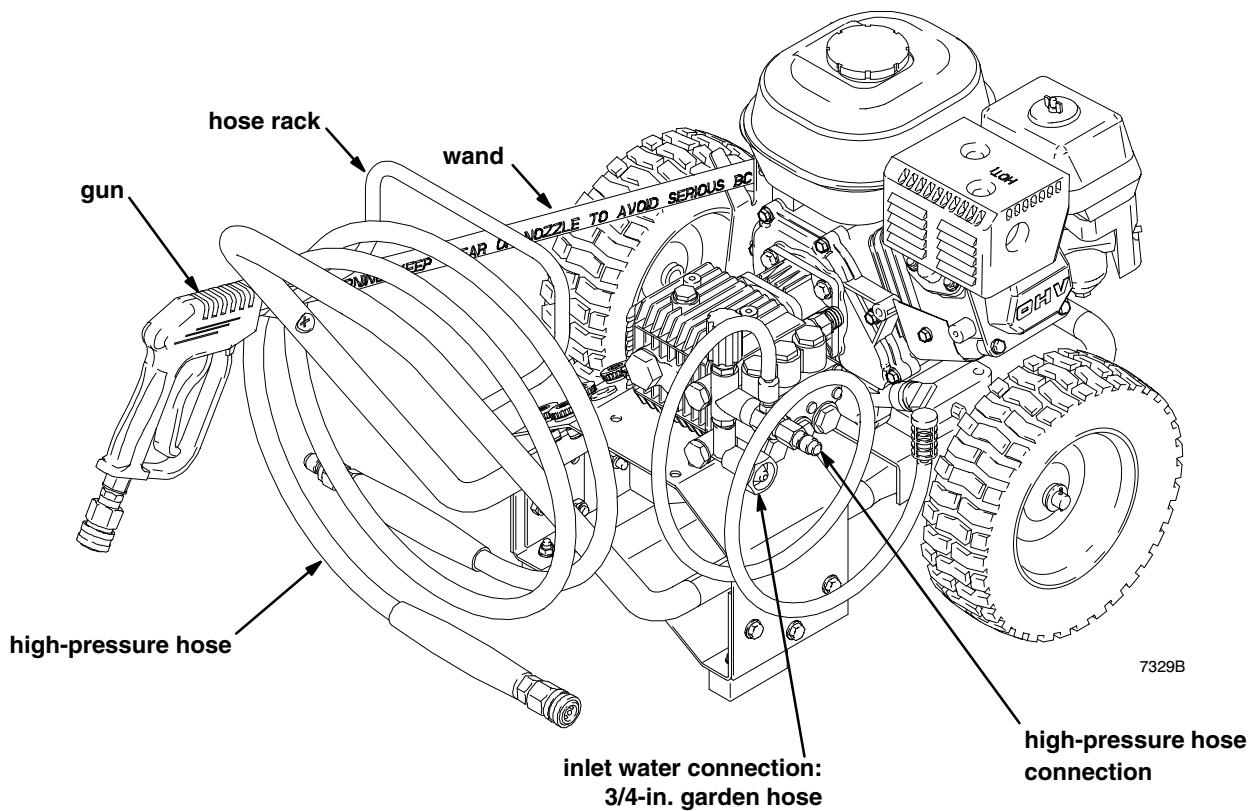

Check for Shipping Damage

Check the pressure washer for shipping damage. **Notify the carrier immediately** if there is any damage.

Connect High-Pressure Hose and Gun

Connect the high-pressure hose between the pump outlet and the gun inlet. Both of these connections are made with quick couplers.

⚠ CAUTION

Up to 100 ft (30 m) of high-pressure hose may be used. Longer hoses could affect pressure washer and chemical injector performance.

Install Spray Tip

Install the appropriate spray tip on the wand. See **Installing and Changing Spray Tips** on page 6. If you are using a Sandblaster Kit, see its separate manual for installation instructions.

Connect to Water Supply

⚠ CAUTION

Before you connect the garden hose to the pressure washer, check your local plumbing code regarding cross-connection to the water supply. If required, install a backflow preventer.

If the inlet water pressure is over 60 psi (4.1 bar), a regulating water valve must be installed at the garden hose connection.

Do not exceed 160° F (70° C) inlet water temperature.

Connect a hose with at least a 3/4-in. (19 mm) ID from the water supply to the 3/4 in. garden hose inlet on the pressure washer. The supply hose should not be more than 50 ft (15 m) long.

NOTE: The water source *must* have a minimum flow rate equal to that of the pressure washer. See **Technical Data** on page 25.

Pressure Relief Procedure

⚠ WARNING



INJECTION HAZARD

The system pressure must be manually relieved to prevent the system from starting or spraying accidentally. Fluid under high pressure can be injected through the skin and cause serious injury. To reduce the risk of injury from injection, splashing fluid, or moving parts, follow the **Pressure Relief Procedure** whenever you

- Are instructed to relieve the pressure
- Stop spraying for more than 10 minutes
- Check or service any of the system equipment
- Install or clean the spray nozzle

1. Engage the trigger safety latch.
2. Turn the pressure washer off, and remove the ignition cable from the spark plug.
4. Shut off the water supply.
5. Disengage the trigger safety latch, and trigger the gun to relieve pressure. Then engage the trigger safety latch.

If you suspect that the spray tip or hose is clogged or that pressure has not been fully relieved after following the steps above: Disengage the trigger safety latch, and trigger the gun to relieve pressure. Wrap a rag around the hose end coupling, and **VERY SLOWLY** loosen the coupling to relieve pressure gradually. Then loosen it completely. Then clear the tip or hose.

Operation

Startup

Always use this startup procedure to ensure that the pressure washer is started safely and properly.

- Always engage the gun trigger safety latch when you stop spraying even for a moment. This reduces the risk of fluid injection or splashing in the eyes or on the skin if the gun is bumped or triggered accidentally.
- Always observe the **CAUTIONS** in this section to avoid costly damage to the pressure washer.
- If you use the Sandblaster Kit, see the Sandblaster Kit manual for detailed cleaning information.

1. Check the oil level.

NOTE: All pressure washers are equipped with a low-oil sensor that shuts the engine off if the oil level falls below a certain level. If the engine stops unexpectedly, check the oil and the fuel levels. Check the oil level each time you add fuel.

2. Check fuel level.

⚠ WARNING



FIRE HAZARD

Do not refuel a hot engine. Refueling a hot engine could cause a fire. Use only fresh, clean, regular or unleaded gasoline. Close the fuel shutoff valve during refueling.

3. Turn on the water supply.

⚠ CAUTION

Never run the pressure washer without water. Costly damage to the pump will result. Always be sure the water supply is completely turned on before you run the pressure washer.

4. Trigger the gun until water sprays from the tip, indicating that the air is purged from the system.
5. Open the fuel shutoff valve. Be sure the spark plug ignition cable is pushed firmly onto the spark plug. Put the switch in the **START** position, and put the throttle in the **RUN** position.

⚠ CAUTION

Do not allow the pressure washer to idle for more than 10 minutes. Doing so could cause the circulating water to overheat and seriously damage the pump. Turn off the pressure washer if it will not be spraying at least every 10 minutes. If heated inlet water is used, reduce this time more. Do not operate the pressure washer with the inlet water screen removed. This screen helps keep abrasive sediment out of the pump, which could clog the pump or damage the cylinders. Keep the screen clean. Do not pump caustic materials; such materials could corrode the pump components.

Operation

- Pull the starter rope to start the engine. Brace one foot on the pressure washer chassis, and pull the starter rope out quickly. Pull and return the rope until the engine starts.

⚠ CAUTION

Do not allow the starter rope to snap back against the engine. Let the rope recoil gently to prevent damage to the recoil.

NOTE: For easier starting, have one person start the pressure washer while another person triggers the gun.

If the engine is cold, start the engine with the choke completely closed. In cool weather, you might have to let the engine run with the choke closed for the first 10 to 30 seconds. In warm weather, open the choke completely as soon as the engine starts.

If the engine is warm, start the engine with the choke completely open or partially closed. When the engine starts, open the choke completely.

Trigger Safety Latch

⚠ WARNING

To reduce the risk of serious bodily injury, including fluid injection and splashing in the eyes or on the skin, always engage the trigger safety latch when you stop spraying even for a moment. When engaged, the trigger safety latch prevents the gun from being triggered accidentally by hand or when dropped or bumped. Be sure the latch is pushed fully down, or it will not prevent the gun from being triggered. See Fig. 1.

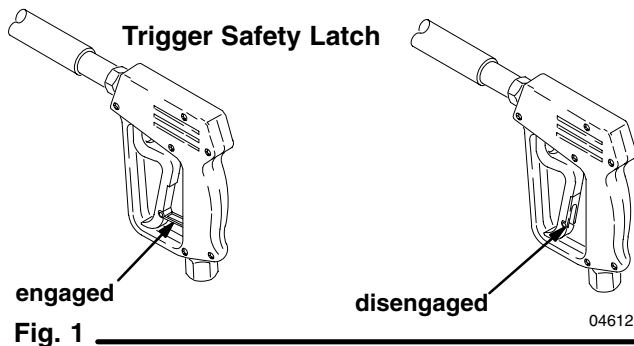



Fig. 1

Chemical Injector Operation

- 

Relieve the pressure. See page 5.
- Insert the chemical filter (attached with clear tubing to the chemical injector) into the container of chemical.
- Install the black large-orifice chemical tip. See **Installing and Changing Spray Tips** below.

The large orifice of the chemical tip causes a drop in pressure that actuates the chemical injector. Changing back to a small-orifice spray tip deactivates the chemical injector and produces high pressure for rinsing. The chemical filter can be left in the chemical container during high-pressure use. To regulate the flow rate of the chemical, turn the chemical adjustment knob on the injector. Maximum chemical flow is a full two turns counterclockwise from the CLOSED (clockwise) position.

Installing and Changing Spray Tips

Spray tips have 4- or 5-digit numbers on them. The first two digits are the spray angle. Select the spray tip appropriate for your application. Tip holding holes are provided on the chassis.

| Spray Tip Number | Spray Pattern Fan Angle |
|------------------|-------------------------|
| 00XXX | 0° blaster (red) |
| 15XXX | 15° (yellow) |
| 25XXX | 25° (green) |
| 40XXX | 40° (white) |

NOTE: The chemical injector tip is brass and has a large opening and a black plastic cap.

- 

Relieve the pressure. See page 5.
- Point the gun and wand away from yourself and anyone else.
- Without holding your hand over the spray tip (A), pull back the quick coupler ring (B). Remove the current tip, and install a different one. Then push back the ring. See Fig. 2.

Operation

- Pull on the tip to be sure the tip is secure before you spray again.

⚠ CAUTION

To avoid blowing the O-ring out of the quick coupler due to the high pressure in the system, never operate the pressure washer without a tip securely mounted in the quick coupler.

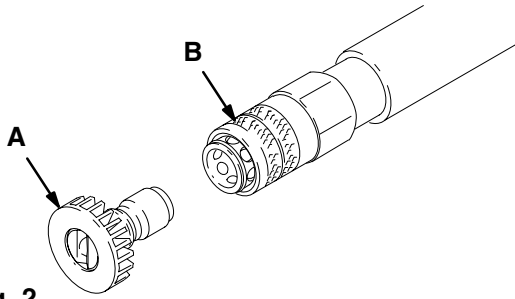

Fig. 2

04929

Shutdown, Flushing, and Storage

⚠ CAUTION

If water freezes in the pressure washer, thaw it in a warm room before you try to start it. Do not pour hot water on or into the pump; it could crack the ceramic plungers.

- If the pressure washer will be exposed to freezing temperatures, drain all water out of the pump. If it must be stored in freezing temperatures, flush the pressure washer with a 50% antifreeze solution, and relieve the pressure. Flush the pressure washer before you use it again to remove the antifreeze.
- Before you store the pressure washer overnight or transport it, disconnect the water supply, and turn off the fuel supply valve.
- After each use, wipe all surfaces of the pressure washer with a clean, damp cloth.
- Perform the appropriate maintenance. See **Maintenance Chart** at right.

Maintenance

Observing regular maintenance intervals helps ensure that you get maximum performance and life from the pressure washer.

There is a break-in period for the engine and pump. After you change the oil in these components following their respective break-in periods, the interval between required changes is longer.

If the pressure washer operated in dusty conditions, these maintenance checks should be made more often.

Maintenance Chart

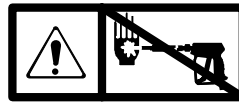

Relieve the pressure

(see page 5) before you proceed with maintenance.

| Interval | What to do |
|---|--|
| Daily | Clean water inlet screen and filter. Check engine and pump oil levels. Fill as necessary. Check gasoline level. Fill as necessary. |
| After first 5 hours of operation | Change engine break-in oil. Drain oil when warm. Use SAE 30 or 10W-30 detergent oil. |
| After every 25 hours of operation | Clean and remove air cleaner foam. Wash with water and detergent. Dry thoroughly. Rub with oil, and squeeze to distribute oil. |
| After first 50 hours of operation | Change pump break-in oil. Use SAE 20 or 30 non-detergent oil. |
| After every 100 hours of operation, or every 3 months | Clean or replace paper air cleaner cartridge. Tap gently to remove dirt. Change engine oil. Use SAE 30 or 10W-30 detergent oil. |
| After every 500 hours of operation, or every 6 months | Change pump oil. Use SAE 20 or 30 non-detergent oil. |

Troubleshooting

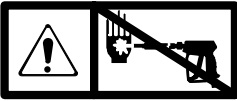

Relieve the pressure (see page 5) before you proceed with troubleshooting.

| Problem | Cause | Solution |
|--|---|---|
| Engine will not start or is hard to start. | <p>No gasoline in fuel tank or carburetor</p> <p>Low oil</p> <p>Start/Stop switch in STOP position</p> <p>Water in fuel, or old fuel</p> <p>Engine flooded or improperly choked</p> <p>Dirty air cleaner filter</p> <p>Spark plug dirty, wrong gap, or wrong type</p> <p>Gun not triggered</p> | <p>Fill the tank with gasoline, and open fuel shutoff valve. Check fuel line and carburetor.</p> <p>Add oil to proper level.</p> <p>Move switch to START position.</p> <p>Drain fuel tank and carburetor. Use new fuel, and make sure spark plug is dry.</p> <p>Open choke, and pull engine starter rope several times to clear out fuel. Make sure spark plug is dry.</p> <p>Remove and clean.</p> <p>Clean, adjust the gap, or replace.</p> <p>Trigger gun while starting engine.</p> |
| Engine misses or lacks power. | <p>Partially plugged air cleaner filter</p> <p>Spark plug dirty, wrong gap, or wrong plug type</p> | <p>Remove and clean.</p> <p>Clean, adjust the gap, or replace.</p> |
| Pressure is too low, and/or pump runs roughly. | <p>Worn or wrong size tip</p> <p>Inlet filter clogged</p> <p>Worn packings, abrasives in water, or natural wear</p> <p>Inadequate water supply</p> <p>Fouled or dirty inlet or discharge valves</p> <p>Restricted inlet</p> <p>Worn inlet or discharge valves</p> <p>Leaking high-pressure hose</p> | <p>Replace with tip of proper size.</p> <p>Clean. Check more frequently.</p> <p>Check filter. Replace packings. See Pump Service on pages 10 and 12.</p> <p>Check water flow rate to pump.</p> <p>Clean inlet and discharge valve assemblies. Check filter.</p> <p>Garden hose might be collapsed or kinked.</p> <p>Replace worn valves. See Pump Service on pages 10 and 12.</p> <p>Replace high-pressure hose.</p> |
| Water leaks from under pump manifold. | <p>Worn packings</p> | <p>Install new packings. See Pump Service on pages 10 and 12.</p> |
| There is water on oil side of pump. | <p>Humid air condensing inside crankcase</p> <p>Worn packings</p> <p>Oil seals leaking</p> | <p>Change oil as specified in Maintenance Chart on page 7.</p> <p>Install new packings. See Pump Service on pages 10 and 12.</p> <p>Install new oil seals. See Pump Service on pages 10 and 12.</p> |

Troubleshooting

| Problem | Cause | Solution |
|--|--|---|
| Packings are failing frequently or prematurely. | Scored, damaged, or worn plungers | Install new plungers. See Pump Service on pages 10 and 12. |
| | Abrasive material in the fluid being pumped | Install proper filtration on pump inlet plumbing. |
| | Inlet water temperature too high | Check water temperature. It should not exceed 160°F (70°C). |
| | Overpressurizing pump | Do not modify any factory-set adjustments. See Equipment Misuse Hazard on page 3. |
| | Excessive pressure due to partially plugged or damaged tip | Clean or replace tip. See Installing and Changing Spray Tips on page 6. |
| | Pump running too long without spraying Running pump dry | Never run pump more than 10 minutes without spraying. Do not run pump without water. |
| There is strong surging at inlet and low pressure on discharge side. | Foreign particles in inlet or discharge valve, or worn inlet and/or discharge valves | Clean or replace valves. See Pump Service on pages 10 and 12. |

Pump Service: 1535 and 2030 Pressure Washers

Repair kits are available. See the individual repair sections, the **Parts Lists** on pages 15 to 23, and **Pump Repair Kits** on pages 21 and 23. For the best results, use all parts in the kits.

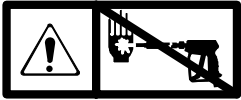

Relieve the pressure
(see page 5) before you proceed with service.

NOTES:

- The following metric wrenches are needed: 5 mm, 13 mm, and 22 mm.
- There is a tool kit to aid in servicing the pump. Tool Kit 800271 includes tools to aid in removing packing retainers.

Valves

NOTE: For a set of six valves, order Valve Assembly Kit 801472.

1. Remove the hex plug from the manifold using a 22 mm socket.
2. Examine the O-ring under the hex plug, and replace if cut or distorted.
3. Remove the valve assembly from the cavity; the assembly might come apart.
4. Install the new valve. Install the O-ring and hex plug. Torque to 33 ft-lb (45 N•m).

NOTE: Retorque the plug after 5 hours of operation.

Pumping Section

1. Remove the eight capscrews and lockwashers from the manifold using a 5 mm wrench.
2. Carefully separate the manifold from the crankcase.

NOTE: You might have to tap the manifold lightly with a soft mallet to loosen it.

⚠ CAUTION

To avoid damage to the plunger or seals, keep the manifold properly aligned with the ceramic plungers when you remove it.

3. Carefully examine each plunger for any scoring or cracking, and replace as necessary.

Servicing the Plungers

NOTE: Plunger Repair Kit 801474 is available to replace retainers, O-rings, washers, and backup rings for three cylinders.

1. Loosen the plunger retaining nut five or six turns using a 13 mm wrench. Push the plunger towards the crankcase to separate the plunger and retaining screw.
2. Remove the nut from the plunger, and examine the O-ring, backup ring, and copper bearing/gasket washer. Replace these parts if necessary using Plunger Repair Kit 801474.
3. Remove the plunger and flinger from the plunger shaft. Clean and replace parts as necessary.
4. Inspect the plunger shaft for oil leakage from the crankcase. If leaking is obvious, replace the oil seals. Otherwise, DO NOT remove these seals, because they cannot be reused. Oil Seal Kits are available for replacing the seals. See **Pump Repair Kits** on page 21.
5. Lightly grease the flinger (and oil seal if it is being replaced), and replace on the plunger shaft. Then install the plunger.

Pump Service: 1535 and 2030 Pressure Washers

6. Lightly grease the retaining screw and the outer end of the plunger. Place the washer, O-ring, and backup ring around the screw, and install the nut through the plunger. Torque to 11 ft-lb (15 N•m).

NOTE: If you plan to replace the packings, see **Servicing the V-packings** at right.

7. Lubricate the outside of each plunger. Slide the manifold onto the crankcase, being careful not to damage the seals.
8. Install the capscrews and washers finger tight. Torque the screws to 8.8 ft-lb (12 N•m) following the tightening pattern (Fig. 3). Uneven tightening could cause the manifold to bind or jam.

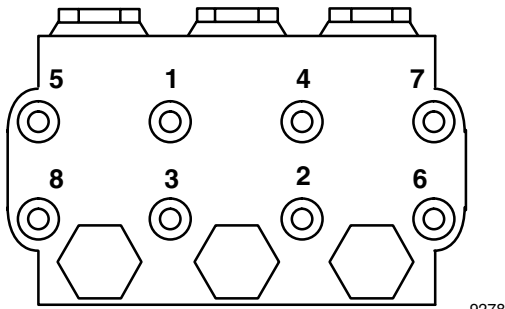

Fig. 3

Servicing the V-Packings

NOTE: There are two types of packing kits: One is packings only. The other includes the packings, rings, and retainers.

1. Remove the manifold as outlined in **Pumping Section** on page 10.
2. Carefully pull the packing retainer from the manifold. Examine the O-ring, and replace if cut or damaged.
3. Remove the V-packing and head ring. Pull out the intermediate retainer ring. Remove the second V-packing and second head ring.
4. Inspect all parts, and replace as necessary.
5. Thoroughly clean the packing cavities, and examine for debris or damage.
6. Lightly grease the packing cavities, and replace the packings in the following order: head ring, V-packing, intermediate ring, head ring, V-packing, packing retainer. Install the O-ring in the retainer groove.

▲ CAUTION

Install the parts in the proper order and facing the proper direction. Improperly installed parts will cause a malfunction.

7. Reassemble the manifold as instructed in **Servicing the Plungers** on page 10.

Pump Service: 2540, 2835, and 3040 Pressure Washers

Repair kits are available. See the individual repair sections, the **Parts Lists** on pages 15 to 23, and **Pump Repair Kits** on pages 21 and 23. For the best results, use all parts in the kits.



Relieve the pressure
(see page 5) before you
proceed with service.

NOTES:

- The following metric wrenches are needed: 6 mm, 13 mm, and 27 mm.
- There is a tool kit to aid in servicing the pump. Tool Kit 800271 includes tools to aid in removing packing retainers.

Valves

NOTE: For a set of six valves, order Valve Assembly Kit 804402.

1. Remove the hex plug from the manifold using a 27 mm socket.
2. Examine the O-ring under the hex plug, and replace if cut or distorted.
3. Remove the valve assembly from the cavity; the assembly might come apart.
4. Install the new valve. Install the O-ring and hex plug. Torque to 73 ft-lb (99 N•m).

NOTE: Retorque the plug after 5 hours of operation.

Pumping Section

1. Remove the eight capscrews and lockwashers from the manifold using a 6 mm wrench.
2. Carefully separate the manifold from the crankcase.

NOTE: You might have to tap the manifold lightly with a soft mallet to loosen it.

⚠ CAUTION

To avoid damage to the plunger or seals, keep the manifold properly aligned with the ceramic plungers when you remove it.

3. Carefully examine each plunger for any scoring or cracking, and replace as necessary.

Servicing the Plungers

NOTE: Plunger Repair Kit 243430 is available to replace retainers, O-rings, washers, and backup rings for three cylinders.

1. Loosen the plunger retaining nut five or six turns using a 13 mm wrench. Push the plunger towards the crankcase to separate the plunger and retaining screw.
2. Remove the nut from the plunger, and examine the O-ring, backup ring, and copper bearing/gasket washer. Replace these parts if necessary using Plunger Repair Kit 243430.
3. Remove the plunger and flinger from the plunger shaft. Clean and replace parts as necessary.
4. Inspect the plunger shaft for oil leakage from the crankcase. If leaking is obvious, replace the oil seals. Otherwise, DO NOT remove these seals, because they cannot be reused. Oil Seal Kits are available for replacing the seals. See **Pump Repair Kits** on page 23.
5. Lightly grease the flinger (and oil seal if it is being replaced), and replace on the plunger shaft. Then install the plunger.

Pump Service: 2540, 2835, and 3040 Pressure Washers

6. Lightly grease the retaining screw and the outer end of the plunger. Place the washer, O-ring, and backup ring around the screw, and install the nut through the plunger. Torque to 14.4 ft-lb (19.5 N•m).

NOTE: If you plan to replace the packings, see **Servicing the V-packings** at right.

7. Lubricate the outside of each plunger. Slide the manifold onto the crankcase, being careful not to damage the seals.
8. Install the capscrews and washers finger tight. Torque the screws to 22 ft-lb (30 N•m) following the tightening pattern (Fig. 4). Uneven tightening could cause the manifold to bind or jam.

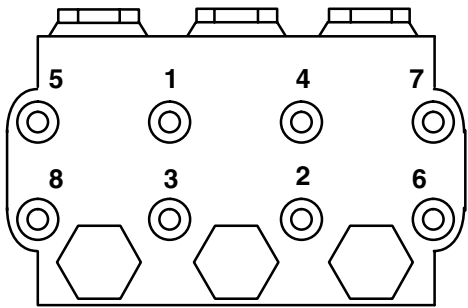

9278

Fig. 4

Servicing the V-Packings

NOTE: There are two types of packing kits: One is packings only. The other includes the packings, rings and retainers.

1. Remove the manifold as outlined in **Pumping Section** on page 12.
2. Carefully pull the packing retainer from the manifold. Examine the O-ring, and replace if cut or damaged.
3. Remove the V-packing and head ring. Pull out the intermediate retainer ring. Remove the second V-packing and second head ring.
4. Inspect all parts, and replace as necessary.
5. Thoroughly clean the packing cavities, and examine for debris or damage.
6. Lightly grease the packing cavities, and replace the packings in the following order: head ring, V-packing, intermediate ring, head ring, V-packing, packing retainer. Install the O-ring in the retainer groove.

▲ CAUTION

Install the parts in the proper order and facing the proper direction. Improperly installed parts will cause a malfunction.

7. Reassemble the manifold as instructed in **Servicing the Plungers** on page 12.

Parts: 1535 and 2030 Pressure Washers

Model 804506, Series A: 1535 Pressure Washer

Model 804532, Series A: 2030 Pressure Washer

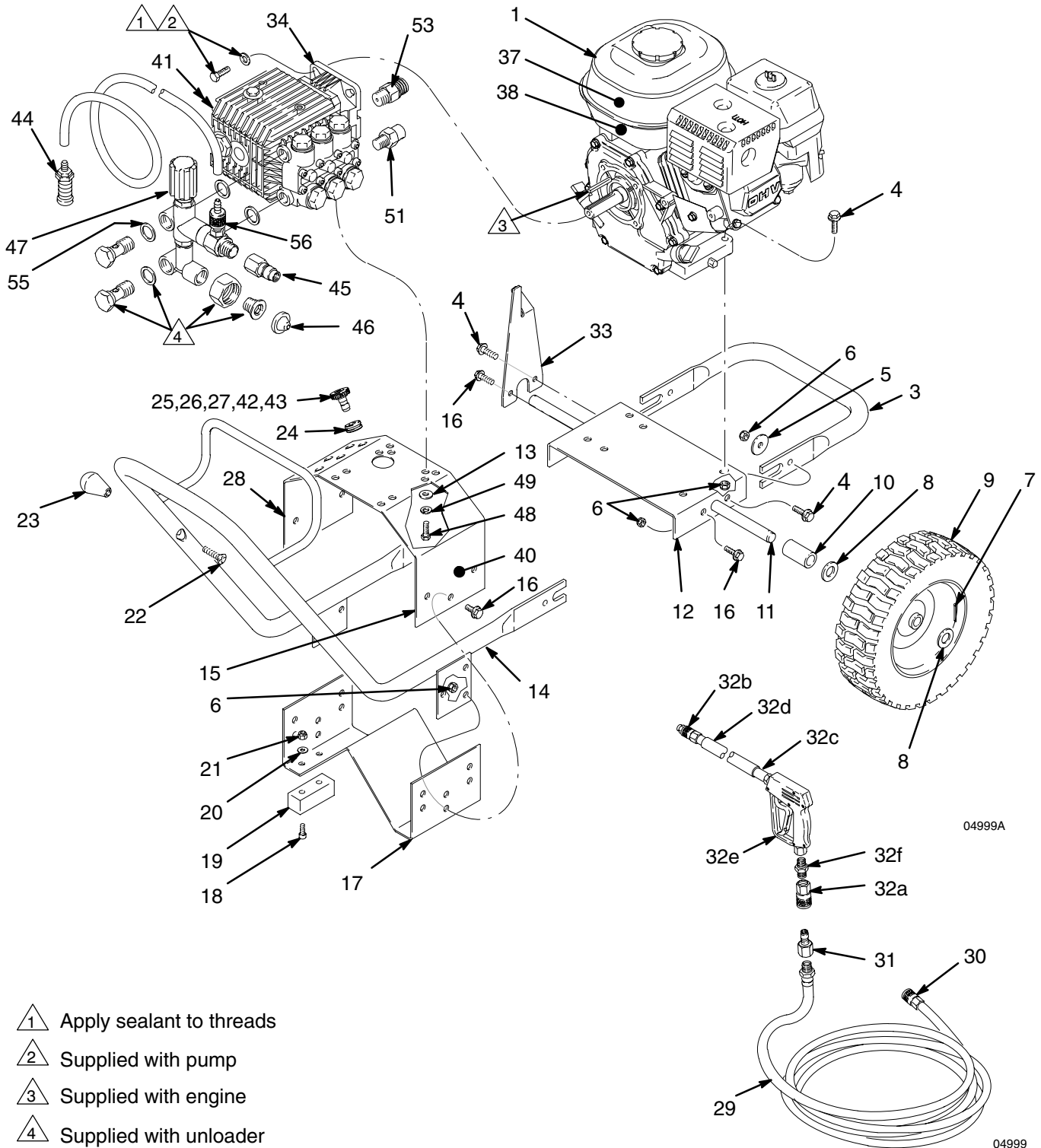

Parts: 1535 and 2030 Pressure Washers

USE ONLY GENUINE GRACO PARTS AND ACCESSORIES

Model 804506, Series A: 1535 Pressure Washer

Model 804532, Series A: 2030 Pressure Washer

| Ref. No. | Part No. | Description | Qty. | Ref. No. | Part No. | Description | Qty. |
|----------|----------|------------------------------|------|----------|----------|---------------------------------|------|
| 1 | 802264 | ENGINE, 5.5 hp | 1 | 29 | 804479 | HOSE, high pressure 3/8 x 50' | 1 |
| 3 | 804510 | HANDLE, lift | 1 | 30 | 801569 | QUICK COUPLER, 3/8 female | 1 |
| 4 | 804533 | SCREW, cap, flange, 5/16-18 | 6 | 31 | 801568 | QUICK COUPLER, 3/8 male | 1 |
| 5 | 804523 | WASHER, handle | 2 | 32 | 800392 | GUN / WAND ASSEMBLY | |
| 6 | 111040 | NUT, lock 5/16-18 | 14 | | | (includes 32a to 32f) | 1 |
| 7 | 101545 | PIN, cotter 1/8 dia. x 1 in. | 2 | 32a | 801569 | •QUICK COUPLER, female 3/8 | 1 |
| 8 | 154636 | WASHER, plain, 1-3/16 | 4 | 32b | 801009 | •QUICK COUPLER, female 1/4 | 1 |
| 9 | 804511 | WHEEL, pneumatic | 2 | 32c | 801134 | •WAND, 32 in. | 1 |
| 10 | 804512 | SPACER | 2 | 32d | 801674 | •SLEEVE, 28 in. | 1 |
| 11 | 804554 | AXLE | 1 | 32e | 803350 | •GUN (see manual 308511) | 1 |
| 12 | 804516 | PLATE, motor mounting | 1 | 32f | 801603 | •NIPPLE, hex, 3/8 npt x 3/8 npt | 1 |
| 13 | 100527 | WASHER, plain | 2 | 33 | 804529 | HOLDER, gun | 1 |
| 14 | 804509 | HANDLE | 1 | 34 | | PUMP ASSEMBLY (see page 20) | 1 |
| 15 | 804514 | PLATE, pump | 1 | | 800740 | 1535 pressure washer | 1 |
| 16 | 114412 | SCREW, flange, hex hd | 8 | | 804544 | 2030 pressure washer | 1 |
| 17 | 804515 | PLATE, bottom | 1 | 37 | 290130 | LABEL | 1 |
| 18 | 100643 | SCREW, cap, sch, 14-20 x .75 | 4 | 38 | 802363 | LABEL, caution | 1 |
| 19 | 109059 | PAD, rubber | 2 | 40 | 290131 | LABEL, warning | 1 |
| 20 | 100086 | WASHER, plain, 3/16 | 4 | 41 | 290133 | LABEL | 1 |
| 21 | 102040 | NUT, lock, hex, 1/4-20 | 4 | 42 | | TIP, spray | 1 |
| 22 | 804530 | SCREW, mach, flthd, 3/8-16 | 1 | | 805558 | 1535 pressure washer | |
| 23 | 108789 | KNOB | 1 | | | 40° (white), 40055 | 1 |
| 24 | 801012 | GROMMET, rubber | 6 | | 805546 | 2030 pressure washer | |
| 25 | | TIP, spray | 1 | | | ,40° (white), 4004 | 1 |
| | 805555 | 1535 pressure washer | | 43 | | TIP, spray, chemical injector | 1 |
| | | 0° (red), 00055 | 1 | | 805634 | 1535 pressure washer (black) | 1 |
| | 805543 | 2030 pressure washer | | | 805634 | 2030 pressure washer (black) | 1 |
| | | 0° (red), 0004 | 1 | 44 | 803885 | STRAINER | 1 |
| 26 | | TIP, spray | 1 | 45 | 803857 | COUPLER, sst | 1 |
| | 805556 | 1535 pressure washer | | 46 | 801112 | SCREEN | 1 |
| | | 15° (yellow), 15055 | 1 | 47 | | KIT, unloader/injector | 1 |
| | 805544 | 2030 pressure washer | | | 804542 | 1535 pressure washer | 1 |
| | | 15° (yellow), 1504 | 1 | | 804543 | 2030 pressure washer | 1 |
| 27 | | TIP, spray | 1 | 48 | 801210 | SCREW | 2 |
| | 805557 | 1535 pressure washer | | 49 | 100214 | WASHER, lock | 2 |
| | | 25° (green), 25055 | 1 | 51 | 800742 | VALVE, thermal relief | 1 |
| | 805545 | 2030 pressure washer | | 53 | | VALVE, relief | 1 |
| | | 25° (green), 2504 | 1 | | 804534 | 1535 pressure washer | 1 |
| 28 | | LABEL | 1 | | 804546 | 2030 pressure washer | 1 |
| | 290139 | 1535 pressure washer | 1 | 55 | 804570 | GASKET | 4 |
| | 290142 | 2030 pressure washer | 1 | 56 | 244350 | KIT, repair, chemical injector | 1 |

Parts: 2540 and 3040 Pressure Washers

Model 804507, Series A: 2540 Pressure Washer
 Model 804508, Series A: 3040 Pressure Washer

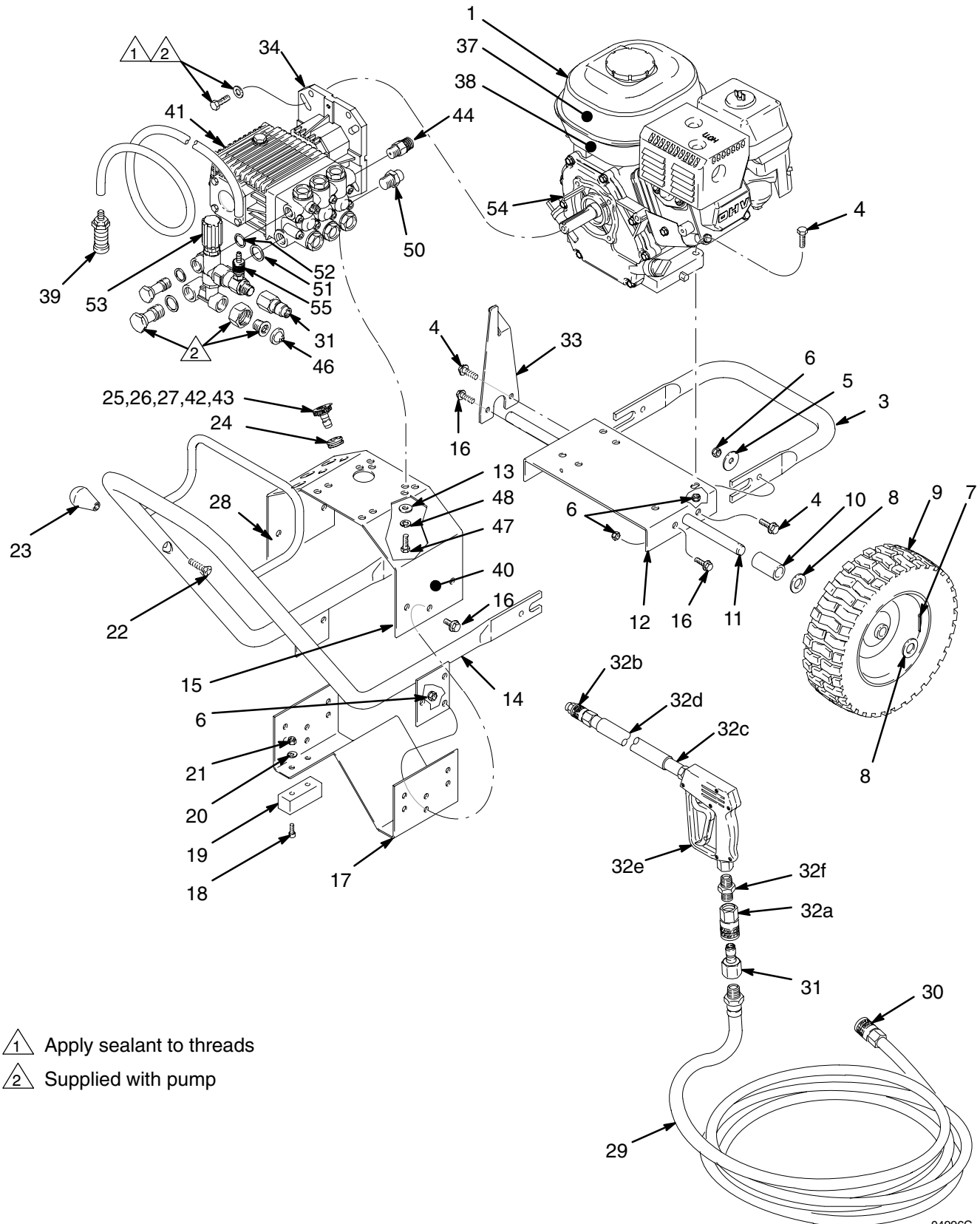

04996C

Parts: 2540 and 3040 Pressure Washers

USE ONLY GENUINE GRACO PARTS AND ACCESSORIES

Model 804507, Series A: 2540 Pressure Washer

Model 804508, Series A: 3040 Pressure Washer

| Ref. No. | Part No. | Description | Qty. | Ref. No. | Part No. | Description | Qty. |
|----------|----------|------------------------------|------|----------|----------|---------------------------------|------|
| 1 | 803900 | ENGINE, 9 hp | | 28 | | LABEL | 1 |
| | | 2540 pressure washer | 1 | | 290140 | 2540 pressure washer | 1 |
| | 803158 | ENGINE, 11 hp | | | 290141 | 3040 pressure washer | 1 |
| | | 3040 pressure washer | 1 | 29 | 804479 | HOSE, high pressure 3/8 x 50' | 1 |
| 3 | 804510 | HANDLE, lift | 1 | 30 | 801569 | QUICK COUPLER, 3/8 female | 1 |
| 4 | 110837 | SCREW, cap, flange, 5/16-18 | 6 | 31 | 801568 | QUICK COUPLER, 3/8 male | 2 |
| 5 | 804523 | WASHER, handle | 2 | 32 | 800392 | GUN / WAND ASSEMBLY | |
| 6 | 111040 | NUT, Lock 5/16-18 | 14 | | | (includes 32a to 32f) | 1 |
| 7 | 101545 | PIN, cotter 1/8 dia. x 1 in. | 2 | 32a | 801569 | •QUICK COUPLER, female 3/8 | 1 |
| 8 | 154636 | WASHER, plain, 1-3/16 | 4 | 32b | 801009 | •QUICK COUPLER, female 1/4 | 1 |
| 9 | 804511 | WHEEL, pneumatic | 2 | 32c | 801134 | •WAND, 32 in. | 1 |
| 10 | 804512 | SPACER | 2 | 32d | 801674 | •SLEEVE, 28 in. | 1 |
| 11 | 804554 | AXLE | 1 | 32e | 803350 | •GUN (see manual 308511) | 1 |
| 12 | 804516 | PLATE, motor mounting | 1 | 32f | 801603 | •NIPPLE, hex, 3/8 npt x 3/8 npt | 1 |
| 13 | 100527 | WASHER, plain | 4 | 33 | 804529 | HOLDER, gun | 1 |
| 14 | 804509 | HANDLE | 1 | 34 | 804540 | PUMP ASSEMBLY (see page 22) | 1 |
| 15 | 804514 | PLATE, pump | 1 | 37 | 290130 | LABEL | 1 |
| 16 | 114412 | SCREW, flange, hex hd | 8 | 38 | 802363 | LABEL, caution | 1 |
| 17 | 804515 | PLATE, bottom | 1 | 39 | 803885 | STRAINER | 1 |
| 18 | 100643 | SCREW, cap, sch, 14-20 x .75 | 4 | 40 | 290131 | LABEL, warning | 1 |
| 19 | 109059 | PAD, rubber | 2 | 41 | 290133 | LABEL | 1 |
| 20 | 100086 | WASHER, plain, 3/16 | 4 | 42 | | TIP, spray | 1 |
| 21 | 102040 | NUT, lock, hex, 1/4-20 | 4 | | 805554 | 2540 pressure washer | |
| 22 | 804530 | SCREW, mach, flthd, 3/8-16 | 1 | | | 40° (white), 4005 | 1 |
| 23 | 108789 | KNOB | 1 | | 805550 | 3040 pressure washer | |
| 24 | 801012 | GROMMET, rubber | 6 | | | 40° (white), 40045 | 1 |
| 25 | | TIP, spray | 1 | 43 | | TIP, spray, chemical injector | 1 |
| | 805551 | 2540 pressure washer | | | 805634 | 2540 pressure washer (black) | 1 |
| | | 0° (red), 0005 | 1 | | 805634 | 3040 pressure washer (black) | 1 |
| | 805547 | 3040 pressure washer | | 44 | 804547 | KIT, repl, relief valve | 1 |
| | | 0° (red), 00045 | 1 | 46 | 804051 | SCREEN | 1 |
| 26 | | TIP, spray | 1 | 47 | 801210 | SCREW | 4 |
| | 805552 | 2540 pressure washer | | 48 | 100214 | WASHER, lock | 4 |
| | | 15° (yellow), 1505 | 1 | 50 | 804397 | VALVE, thermal relief | 1 |
| | 805548 | 3040 pressure washer | | 51 | 804569 | GASKET, unloader | 1 |
| | | 15° (yellow), 15045 | 1 | 52 | 804570 | GASKET | 1 |
| 27 | | TIP, spray | 1 | 53 | | UNLOADER/INJECTOR | 1 |
| | 805553 | 2540 pressure washer | | | 804527 | 2540 pressure washer | 1 |
| | | 25° (green), 2505 | 1 | | 804528 | 3040 pressure washer | 1 |
| | 805549 | 3040 pressure washer | | 54 | 801137 | KEY, square | 1 |
| | | 25° (green), 25045 | 1 | 55 | 244350 | KIT, repair, chemical injector | 1 |

Parts: 2835 Pressure Washer

Model 804583, Series A

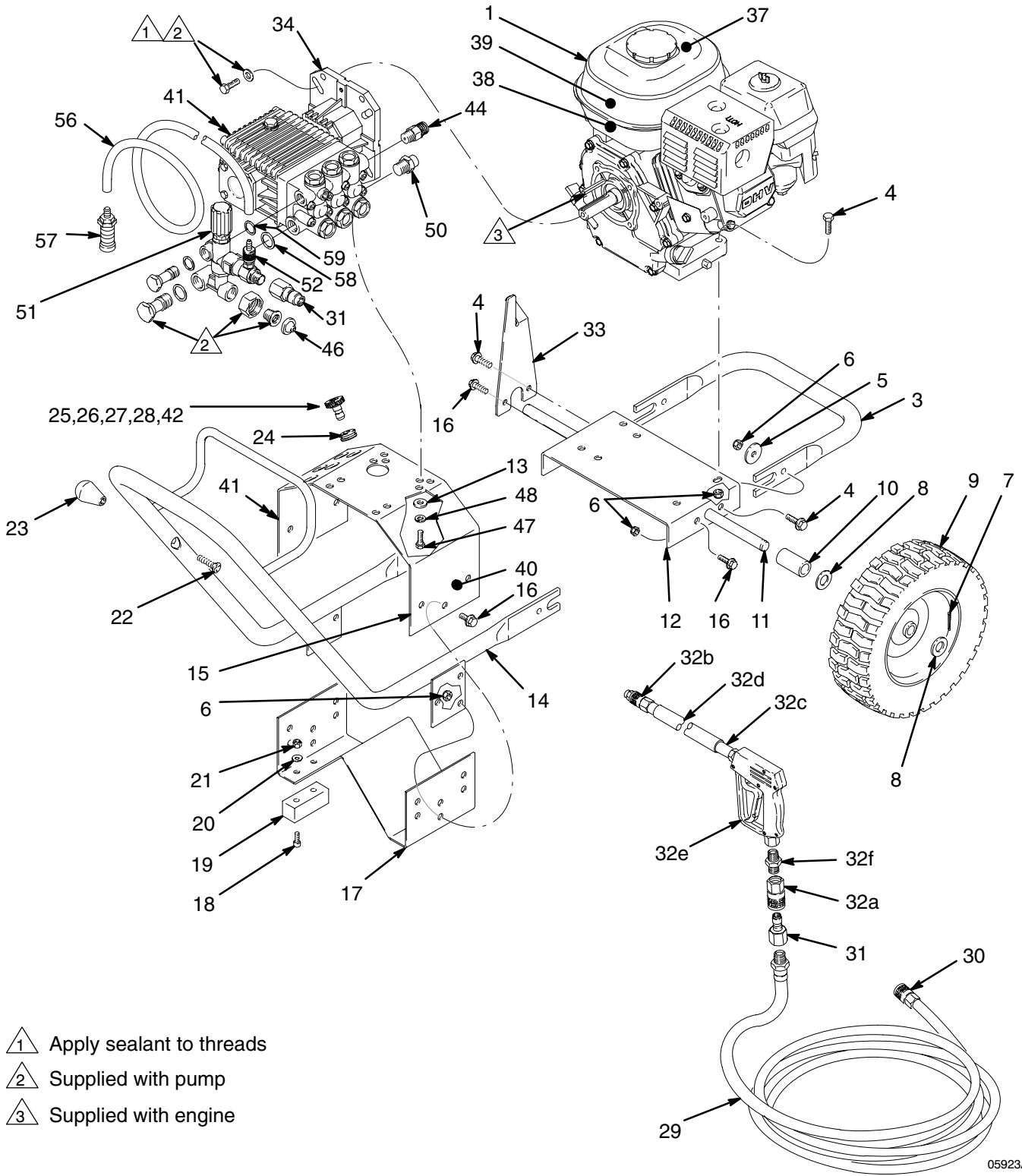

Parts: 2835 Pressure Washer

USE ONLY GENUINE GRACO PARTS AND ACCESSORIES

Model 804583, Series A

| Ref. No. | Part No. | Description | Qty. | Ref. No. | Part No. | Description | Qty. |
|----------|----------|--------------------------------|------|----------|----------|--|------|
| 1 | 803900 | ENGINE, 9 hp | 1 | 30 | 801569 | QUICK COUPLER, 3/8 female | 1 |
| 3 | 804510 | HANDLE, lift | 1 | 31 | 801568 | QUICK COUPLER, 3/8 male | 2 |
| 4 | 110837 | SCREW, cap, flange, 5/16-18 | 6 | 32 | 800392 | GUN / WAND ASSEMBLY (includes 32a to 32f) | 1 |
| 5 | 804523 | WASHER, handle | 2 | 32a | 801569 | •QUICK COUPLER, female 3/8 | 1 |
| 6 | 111040 | NUT, lock 5/16-18 | 14 | 32b | 801009 | •QUICK COUPLER, female 1/4 | 1 |
| 7 | 101545 | PIN, cotter 1/8 dia. x 1 in. | 2 | 32c | 801134 | •WAND, 32 in. | 1 |
| 8 | 154636 | WASHER, plain, 1-3/16 | 4 | 32d | 801674 | •SLEEVE, 28 in. | 1 |
| 9 | 804511 | WHEEL, pneumatic | 2 | 32e | 803350 | •GUN (see manual 308511) | 1 |
| 10 | 804512 | SPACER | 2 | 32f | 801603 | •NIPPLE, hex, 3/8 npt x 3/8 npt | 1 |
| 11 | 804554 | AXLE | 1 | 33 | 804529 | HOLDER, gun | 1 |
| 12 | 804516 | PLATE, motor mounting | 1 | 34 | 804559 | PUMP ASSEMBLY (see page 22) | 1 |
| 13 | 100527 | WASHER, plain | 4 | 37 | 290013 | LABEL | 1 |
| 14 | 804509 | HANDLE | 1 | 38 | 802363 | LABEL, caution | 1 |
| 15 | 804514 | PLATE, pump | 1 | 39 | 820137 | LABEL | 1 |
| 16 | 114412 | SCREW, flange, hex hd | 8 | 40 | 290131 | LABEL, warning | 1 |
| 17 | 804515 | PLATE, bottom | 1 | 41 | 290557 | LABEL | 1 |
| 18 | 100643 | SCREW, cap, sch, 14-20 x .75 | 4 | 42 | 805634 | TIP, spray, chemical injector | 1 |
| 19 | 109059 | PAD, rubber | 2 | 44 | 804536 | VALVE, relief | 1 |
| 20 | 100086 | WASHER, plain, 3/16 | 4 | 46 | 804051 | SCREEN | 1 |
| 21 | 102040 | NUT, lock, hex, 1/4-20 | 4 | 47 | 801210 | SCREW | 4 |
| 22 | 804530 | SCREW, mach, flthd, 3/8-16 | 1 | 48 | 100214 | WASHER, lock | 4 |
| 23 | 108789 | KNOB | 1 | 50 | 804397 | VALVE, thermal relief | 1 |
| 24 | 801012 | GROMMET, rubber | 6 | 51 | 804567 | KIT, unloader/injector | 1 |
| 25 | 805543 | TIP, spray; 0° (red), 0004 | 1 | 52 | 244350 | KIT, repair, chemical injector | 1 |
| 26 | 805544 | TIP, spray; 15° (yellow), 1504 | 1 | 56 | 804275 | TUBE, chemical | 1 |
| 27 | 805545 | TIP, spray; 25° (green), 2504 | 1 | 57 | 801683 | STRAINER | 1 |
| 28 | 805546 | TIP, spray; 40° (white), 4004 | 1 | 58 | 804569 | GASKET, unloader | 1 |
| 29 | 804479 | HOSE, high pressure 3/8 x 50' | 1 | 59 | 804570 | GASKET | 1 |

Parts: Pump Assembly for 1535 and 2030 Pressure Washers

Pump Models 800740 and 804544

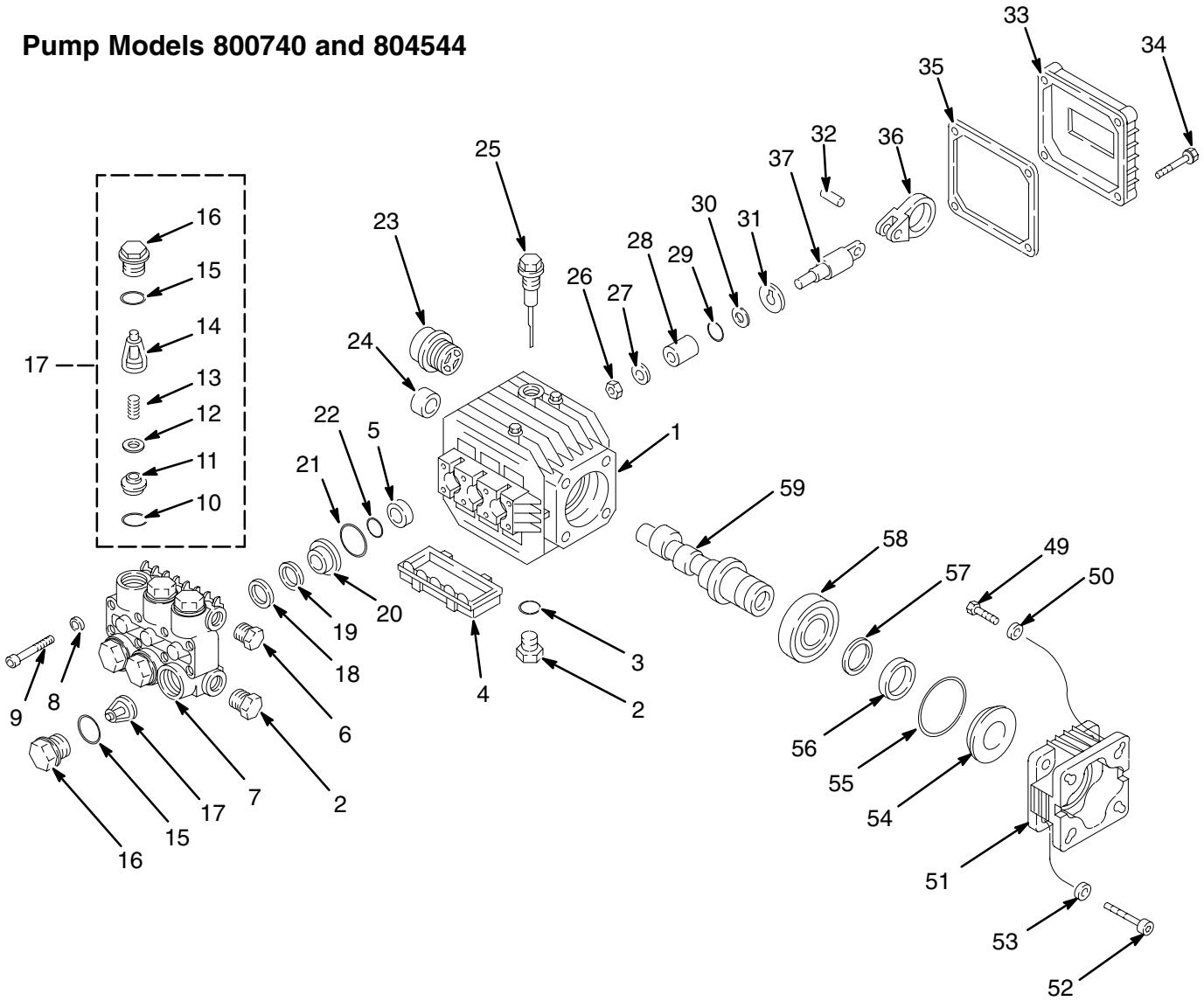

05001

Parts: Pump Assembly for 1535 and 2030 Pressure Washers

USE ONLY GENUINE GRACO PARTS AND ACCESSORIES

Pump Models 800740 and 804544

| Ref. No. | Part No. | Description | Qty. | Ref. No. | Part No. | Description | Qty. |
|----------|-----------|-------------------|------|----------|----------|---------------------|------|
| 1 | | CRANKCASE | 1 | 25 | 801659 | DIPSTICK | 1 |
| 2 | 801484 | PLUG | 2 | 26 | 803920 | NUT | 3 |
| 3 | | O-RING | 1 | 27 | 803921 | WASHER | 3 |
| 4 | | PROTECTOR | 1 | 28 | 804011 | PLUNGER | 3 |
| 5 | KIT 83 | SEAL, oil | | 29 | 803918 | O-RING | 3 |
| 6 | 801753 | PLUG | 1 | 30 | 803919 | RING, backup | 3 |
| 7 | | MANIFOLD | 1 | 31 | 803922 | WASHER, flinger | 3 |
| 8 | 803278 | WASHER | 8 | 32 | | PIN, connecting rod | 3 |
| 9 | 804027 | SCREW | 8 | 33 | | COVER, crankcase | 1 |
| 10 | KIT 1 | O-RING | | 34 | | SCREW | 4 |
| 11 | KIT 1 | SEAT, valve | | 35 | | GASKET, cover | 1 |
| 12 | KIT 1 | PLATE, valve | | 36 | 804010 | END, connecting rod | 3 |
| 13 | KIT 1 | SPRING | | 37 | 804012 | ROD, connecting | 3 |
| 14 | KIT 1 | CAGE, valve | | 49 | 804028 | SCREW | 4 |
| 15 | KIT 84 | O-RING | | 50 | 801652 | WASHER | 4 |
| 16 | KIT 84 | CAP, valve | | 51 | | FLANGE | 1 |
| 17 | KIT 1 | VALVE ASSEMBLY | | 52 | | SCREW | 4 |
| 18 | KIT 96,97 | RING, head | | 53 | | WASHER | 4 |
| 19 | KIT 96,97 | PACKING | | 54 | 803281 | SPACER | 1 |
| 20 | KIT 96 | RETAINER, packing | | 55 | 803268 | O-RING | 1 |
| 21 | KIT 96,97 | O-RING | | 56 | 804018 | SEAL, oil | 1 |
| 22 | KIT 96,97 | O-RING | | 57 | | RING, snap | 1 |
| 23 | 802345 | GAUGE, sight | 1 | 58 | | BEARING | 1 |
| 24 | 804021 | BEARING | 1 | 59 | | CRANKSHAFT | 1 |

Pump Repair Kits

| Kit No. | Repair Kit Part No. | Ref. No. | Description | Qty. | Entire Pump | One Cylinder |
|---------|-------------------------|--|--|----------------------------|-------------|--------------|
| 1 | 801472 Valve Assembly | 10 11 12 13 14 or 17 * | O-RING SEAT, valve PLATE, valve SPRING CAGE, valve VALVE ASSEMBLY | 6 6 6 6 6 6 | ** | |
| 83 | 804033 Oil Seal | 5 | SEAL, oil | 3 | ** | |
| 84 | 804034 Valve Cap | 15 16 | O-RING CAP, valve | 6 6 | ** | |
| 96 | 804036 Packing Assembly | 18 19 20 21 22 | RING, head PACKING RETAINER, packing O-RING O-RING | 1 1 1 1 1 | | ** |
| 97 | 804037 Packing | 18 19 21 22 | RING, head PACKING O-RING O-RING | 3 3 3 3 | ** | |

* Item 17 consists of items 10 to 14. See **Pump Assembly** illustration on facing page.

** Designates whether kit contains parts for entire pump or for only one cylinder.

Parts: Pump Assembly for 2540, 2835, and 3040 Pressure Washers

Pump Models 804540 and 804559

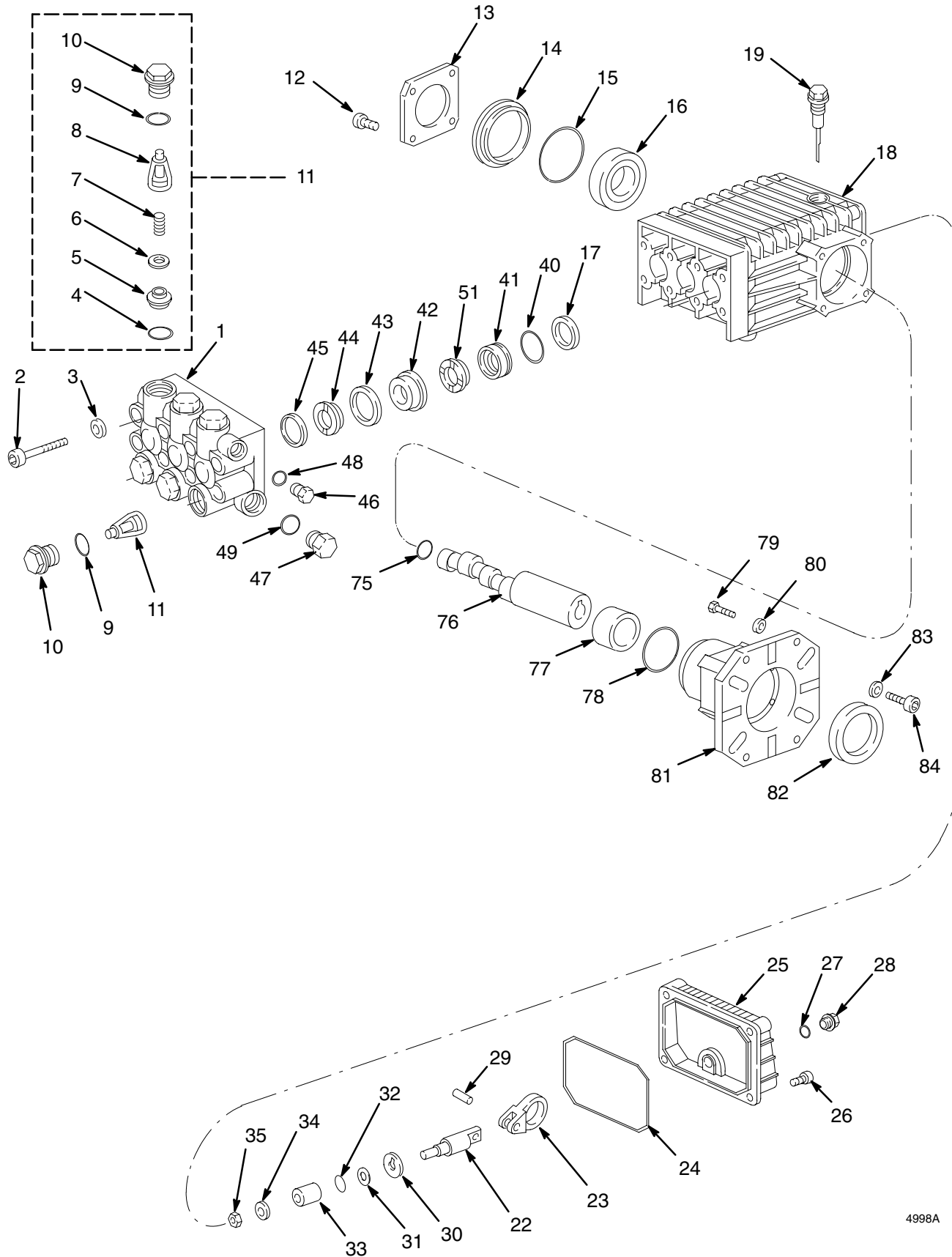

4998A

Parts: Pump Assembly for 2540, 2835, and 3040 Pressure Washers

USE ONLY GENUINE GRACO PARTS AND ACCESSORIES

Pump Models 804540 and 804559

| Ref. No. | Part No. | Description | Qty. | Ref. No. | Part No. | Description | Qty. |
|----------|----------|-----------------|------|----------|----------|----------------------|------|
| 1 | | HEAD, pump | 1 | 30 | 804414 | WASHER | 3 |
| 2 | 801651 | SCREW | 8 | 31 | 803919 | RING, anti extrusion | 3 |
| 3 | 801652 | WASHER | 8 | 32 | 803918 | O-RING | 3 |
| 4 | KIT 123 | O-RING | | 33 | 804415 | PISTON | 3 |
| 5 | KIT 123 | SEAT, valve | | 34 | 803921 | WASHER | 3 |
| 6 | KIT 123 | VALVE | | 35 | 803920 | NUT | 3 |
| 7 | KIT 123 | SPRING | | 40 | KIT 130 | O-RING | |
| 8 | KIT 123 | CAGE, valve | | 41 | KIT 130 | RETAINER, packing | |
| 9 | KIT 124 | O-RING | | 42 | KIT 130 | RING, intermediate | |
| 10 | KIT 124 | CAP | | 43 | KIT 130 | PACKING | |
| 11 | KIT 123 | VALVE ASSEMBLY | | 44 | KIT 130 | PACKING | |
| 12 | | SCREW | 8 | 45 | KIT 130 | RING, head | |
| 13 | | COVER, bearing | 2 | 46 | | SCREW, cap | 1 |
| 14 | | SPACER | 1 | 47 | 801482 | SCREW, cap | 1 |
| 15 | 803268 | O-RING | 1 | 48 | 801485 | WASHER | 1 |
| 16 | | BEARING | 2 | 49 | | WASHER | 1 |
| 17 | KIT 23 | SEAL, oil | | 51 | 115709 | SEAL, low pressure | 1 |
| 18 | | CRANKCASE | 1 | 75 | | RING, retaining | 1 |
| 19 | 801659 | DIPSTICK | 1 | 76 | | CRANKSHAFT | 1 |
| 22 | | GUIDE, piston | 3 | 77 | | BEARING | 1 |
| 23 | | ROD, connecting | 3 | 78 | | O-RING | 1 |
| 24 | | O-RING | 1 | 79 | | SCREW | 4 |
| 25 | | COVER, rear | 1 | 80 | | WASHER | 4 |
| 26 | | SCREW | 5 | 81 | | FLANGE | 1 |
| 27 | 801488 | O-RING | 1 | 82 | 804422 | SEAL, oil | 1 |
| 28 | | SCREW, cap | 1 | 83 | | WASHER | 4 |
| 29 | | PIN | 3 | 84 | | SCREW | 4 |

Pump Repair Kits

| Kit No. | Repair Kit Part No. | Ref. No. | Description | Qty. | Entire Pump | One Cylinder |
|---------|-----------------------------------|------------------------------------|---|--------------------------------|-------------|--------------|
| 23 | 801658 Oil Seal | 17 | SEAL, oil | 3 | ** | |
| 123 | 804402 Valve Assembly | 4 5 6 7 8 or 11* | O-RING SEAT, valve VALVE SPRING CAGE, valve VALVE ASSEMBLY | 6 6 6 6 6 6 | ** | |
| 124 | 804403 Valve Cap | 9 10 | O-RING CAP | 6 6 | ** | |
| 130 | 804404 Packing Assembly | 40 41 42 43 44 45 | O-RING RETAINER, packing RING, intermediate PACKING PACKING RING, head | 1 1 1 1 2 2 | | ** |
| | 243430 Plunger Repair | 30 31 32 34 35 | WASHER RING, anti extrusion O-RING WASHER NUT | 3 3 3 3 3 | ** | |

* Item 11 consists of items 4 to 8. See **Pump Assembly** illustration on facing page.

** Designates whether kit contains parts for entire pump or for only one cylinder.

Accessories

Water Sandblasting Kit 800120

For abrasive cleaning of stubborn dirt and paint. Requires a sandblasting tip, sold separately as follows:

- 1535 pressure washer uses sandblasting tip 805325.
- 2030 pressure washer uses sandblasting tip 805313.
- 2540 pressure washer uses sandblasting tip 805321.
- 2835 pressure washer uses sandblasting tip 805313.
- 3040 pressure washer uses sandblasting tip 805317.

Technical Data

| | 1535 Model 804506 | 2030 Model 804532 | 2540 Model 804507 | 2835 Model 804583 | 3040 Model 804508 |
|---|---|------------------------------------|------------------------------------|------------------------------------|------------------------------------|
| Engine (4 cycle, air cooled) | 5.5 HP Honda™ OHV | 5.5 HP Honda OHV | 9 HP Honda OHV | 9 HP Honda OHV | 11 HP Honda OHV |
| Gasoline tank capacity | 3.8 quarts (3.6 liters) | 3.8 quarts (3.6 liters) | 6.2 quarts (6.1 liters) | 6.2 quarts (6.1 liters) | 6.9 quarts (6.5 liters) |
| Maximum operating pressure | 1500 psi (102 bar, 10.2 MPa) | 2000 psi (138 bar, 13.8 MPa) | 2500 psi (172 bar, 17.2 MPa) | 2800 psi (193 bar, 19.3 MPa) | 3000 psi (210 bar, 21.0 MPa) |
| Water pump maximum working pressure | 1900 psi (131 bar, 13.1 MPa) | 2400 psi (165 bar, 16.5 MPa) | 2900 psi (200 bar, 20.0 MPa) | 3200 psi (221 bar, 22.1 MPa) | 3400 psi (234 bar, 23.4 MPa) |
| Water pump maximum flow | 3.5 gpm (13 lpm) | 3 gpm (11 lpm) | 4 gpm (15 lpm) | 3.5 gpm (13 lpm) | 4 gpm (15 lpm) |
| Inlet hose connection | 3/4-in. garden hose (f) | 3/4-in. garden hose (f) | 3/4-in. garden hose (f) | 3/4-in. garden hose (f) | 3/4-in. garden hose (f) |
| Weight (without gun and hose) | 79 lb (36 kg) | 79 lb (36 kg) | 110 lb (50 kg) | 110 lb (50 kg) | 128 lb (58 kg) |
| Dimensions | | | | | |
| Length | 34.5 in. (940 mm) | 34.5 in. (914 mm) | 34.5 in. (914 mm) | 34.5 in. (914 mm) | 34.5 in. (914 mm) |
| Width | 22 in. (483 mm) | 22 in. (533 mm) | 22 in. (533 mm) | 22 in. (533 mm) | 22 in. (533 mm) |
| Height | 23.5 in. (508 mm) | 23.5 in. (572 mm) | 23.5 in. (572 mm) | 23.5 in. (572 mm) | 23.5 in. (572 mm) |
| Maximum inlet water temperature | 160°F (70°C) | 160°F (70°C) | 160°F (70°C) | 160°F (70°C) | 160°F (70°C) |
| Sound data (per ISO 3744) | | | | | |
| Sound pressure | 93.1 dB(A) | 93.1 dB(A) | 94.3 dB(A) | 94.3 dB(A) | 95.8 dB(A) |
| Sound level | 103.5 dB(A) | 103.5 dB(A) | 104.7 dB(A) | 104.7 dB(A) | 106.3 dB(A) |
| Wetted parts | | | | | |
| High-pressure hose | acrylonitrile and buna-N cover and tube | | | | |
| Bypass hose | synthetic yarn and EPDM | | | | |
| Pressure washer (including fittings) | anodized aluminum; aluminum or bronze alloys; brass copper; Nylon-PTFE composite; ceramic; buna-N; cotton phenolic; 303, 304, and 316 stainless steel; polyamide-12 thermoplastic; PTFE; carbon steel; zinc with or without yellow chromate plate | | | | |

PTFE® is a registered trademark

Honda™ is a trademark of the Honda Corporation.

Graco Warranty

Graco warrants all equipment listed in this manual which is manufactured by Graco and bearing its name to be free from defects in material and workmanship on the date of sale by an authorized Graco distributor to the original purchaser for use. With the exception of any special extended or limited warranty published by Graco, Graco will, for a period of twelve months from the date of sale, repair or replace any part of the equipment determined by Graco to be defective. This warranty applies only when the equipment is installed, operated and maintained in accordance with Graco's written recommendations.

This warranty does not cover, and Graco shall not be liable for general wear and tear, or any malfunction, damage or wear caused by faulty installation, misapplication, abrasion, corrosion, inadequate or improper maintenance, negligence, accident, tampering, or substitution of non-Graco component parts. Nor shall Graco be liable for malfunction, damage or wear caused by the incompatibility of Graco equipment with structures, accessories, equipment or materials not supplied by Graco, or the improper design, manufacture, installation, operation or maintenance of structures, accessories, equipment or materials not supplied by Graco.

This warranty is conditioned upon the prepaid return of the equipment claimed to be defective to an authorized Graco distributor for verification of the claimed defect. If the claimed defect is verified, Graco will repair or replace free of charge any defective parts. The equipment will be returned to the original purchaser transportation prepaid. If inspection of the equipment does not disclose any defect in material or workmanship, repairs will be made at a reasonable charge, which charges may include the costs of parts, labor, and transportation.

Graco's sole obligation and buyer's sole remedy for any breach of warranty shall be as set forth above. The buyer agrees that no other remedy (including, but not limited to, incidental or consequential damages for lost profits, lost sales, injury to person or property, or any other incidental or consequential loss) shall be available. Any action for breach of warranty must be brought within two (2) years of the date of sale.

GRACO MAKES NO WARRANTY, AND DISCLAIMS ALL IMPLIED WARRANTIES OF MERCHANTABILITY AND FITNESS FOR A PARTICULAR PURPOSE IN CONNECTION WITH ACCESSORIES, EQUIPMENT, MATERIALS OR COMPONENTS SOLD BUT NOT MANUFACTURED BY GRACO. These items sold, but not manufactured by Graco (such as electric motors, gas engines, switches, hose, etc.), are subject to the warranty, if any, of their manufacturer. Graco will provide purchaser with reasonable assistance in making any claim for breach of these warranties.

In no event will Graco be liable for indirect, incidental, special or consequential damages resulting from Graco supplying equipment hereunder, or the furnishing, performance, or use of any products or other goods sold hereto, whether due to a breach of contract, breach of warranty, the negligence of Graco, or otherwise.

FOR GRACO CANADA CUSTOMERS

The parties acknowledge that they have required that the present document, as well as all documents, notices and legal proceedings entered into, given or instituted pursuant hereto or relating directly or indirectly hereto, be drawn up in English. Les parties reconnaissent avoir convenu que la rédaction du présente document sera en Anglais, ainsi que tous documents, avis et procédures judiciaires exécutés, donnés ou intentés à la suite de ou en rapport, directement ou indirectement, avec les procédures concernées.

ADDITIONAL WARRANTY COVERAGE

Graco does provide extended warranty and wear warranty for products described in the "Graco Contractor Equipment Warranty Program".

Graco Phone Number

TO PLACE AN ORDER, contact your Graco distributor, or call this number to identify the distributor closest to you:
1-800-690-2894 Toll Free

*All written and visual data contained in this document reflect the latest product information available at the time of publication.
Graco reserves the right to make changes at any time without notice.*

Sales Offices: Minneapolis, Detroit
International Offices: Belgium, Korea, Hong Kong, Japan

GRACO INC. P.O. BOX 1441 MINNEAPOLIS, MN 55440-1441

www.graco.com

PRINTED IN USA 308572 05/1995, Revised 9/2003