

Instructions–Parts List

Carbon Steel



Check–Mate™ 800 Displacement Pump

308570H

EN

For use with hot–melt applications.

Part No. 253141 Pump, Series B,
55 Gallon (200 Liter) Drum Size
5850 psi (40 MPa, 403 bar) Maximum Fluid Working Pressure

Part No. 237795 Pump, Series C,
55 Gallon (200 Liter) Drum Size
5850 psi (40 MPa, 403 bar) Maximum Fluid Working Pressure

Part No. 237885 Pump, Series C,
5 Gallon (19 Liter) Pail Size
5850 psi (40 MPa, 403 bar) Maximum Fluid Working Pressure

Refer to page 2 for Table of Contents.



Important Safety Instructions

Read all warnings and instructions in this manual.
Save these instructions.

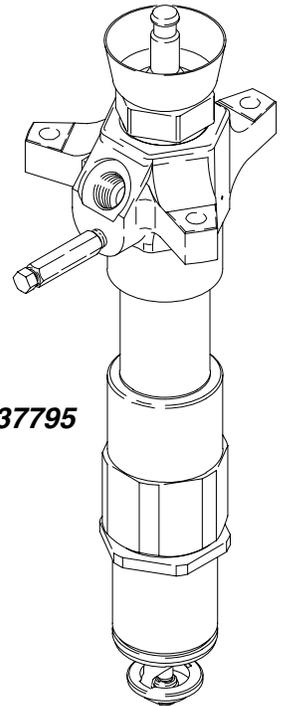

Model 237795

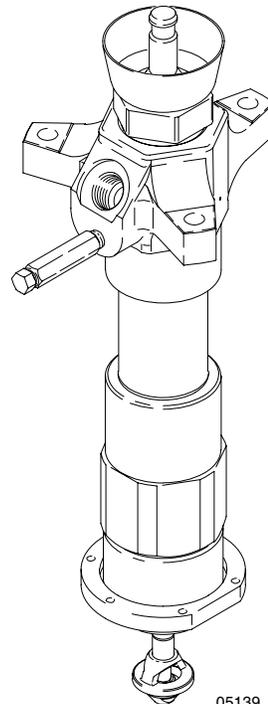

05137

05139

Table of Contents

Symbols	2
Warnings	2
Installation	5
Operation/Maintenance	7
Service	
Required Tools	8
Disconnecting the Displacement Pump	8
Servicing the Throat Packings	9
Servicing the Priming Piston	11
Servicing the Intake Valve	12
Servicing the Piston	14
Parts	16
Technical Data	23
Warranty	NO TAG
Toll-Free Graco Phone Number	NO TAG

Symbols

Warning Symbol



This symbol alerts you to the possibility of serious injury or death if you do not follow the instructions.

Caution Symbol



This symbol alerts you to the possibility of damage to or destruction of equipment if you do not follow the instructions.

! WARNING



INSTRUCTIONS

EQUIPMENT MISUSE HAZARD

Equipment misuse can cause the equipment to rupture or malfunction and result in serious injury.

- This equipment is for professional use only.
- Read all instruction manuals, tags, and labels before operating the equipment.
- Use the equipment only for its intended purpose. If you are not sure, call your Graco distributor.
- Do not alter or modify this equipment.
- Check equipment daily. Repair or replace worn or damaged parts immediately.
- Do not exceed the maximum working pressure stated on the equipment or in the **Technical Data** for your equipment. Do not exceed the maximum working pressure of the lowest rated component in your system.
- Use fluids and solvents which are compatible with the equipment wetted parts. Refer to the **Technical Data** section of all equipment manuals. Read the fluid and solvent manufacturer's warnings.
- Wear hearing protection when operating this equipment.
- Comply with all applicable local, state, and national fire, electrical, and safety regulations.



HOT SURFACE AND FLUID HAZARD

Heated fluid can cause severe burns and can cause equipment surfaces to become very hot.

- Wear protective gloves and clothing when operating this equipment in a heated system.
- Allow the equipment to cool thoroughly before servicing.

WARNING

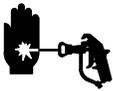

SKIN INJECTION HAZARD

High-pressure fluid from gun, hose leaks, or ruptured components will pierce skin. This may look like just a cut, but it is a serious injury that can result in amputation. **GET IMMEDIATE SURGICAL TREATMENT.**



- Do not point the gun/valve at anyone or at any part of the body.
- Do not put your hand or fingers over the nozzle.
- Do not stop or deflect leaks with your hand, body, glove or rag.
- Always have the trigger guard on the gun/valve when dispensing.
- Be sure the gun/valve trigger safety operates before dispensing.
- Lock the gun/valve trigger safety when you stop dispensing.
- Follow the **Pressure Relief Procedure** on page 7 if the nozzle clogs and before cleaning, checking or servicing the equipment.
- Tighten all fluid connections before operating the equipment.
- Check the hoses, tubes, and couplings daily. Replace worn or damaged parts immediately. Do not repair high pressure couplings; you must replace the entire hose.
- Fluid hoses must have spring guards on both ends, to help protect them from rupture caused by kinks or bends near the couplings.



MOVING PARTS HAZARD

Moving parts, such as the priming piston, can pinch or amputate your fingers.

- Keep clear of all moving parts when starting or operating the pump.
- Keep hands and fingers away from the priming piston during operation and whenever the pump is charged with air.
- Before servicing the equipment, follow the **Pressure Relief Procedure** on page 7 to prevent the equipment from starting unexpectedly.

WARNING



FIRE AND EXPLOSION HAZARD

Improper grounding, poor ventilation, open flames or sparks can cause a hazardous condition and result in a fire or explosion and serious injury.

- Ground the equipment and the object being dispensed to. Refer to **Grounding** on page 5.
- If there is any static sparking or you feel an electric shock while using this equipment, **stop dispensing immediately**. Do not use the equipment until you identify and correct the problem.
- Provide fresh air ventilation to avoid the buildup of flammable fumes from solvents or the fluid being dispensed.
- Keep the dispense area free of debris, including solvent, rags, and gasoline.
- Extinguish all open flames or pilot lights in the dispense area.
- Do not smoke in the dispense area.
- Do not operate a gasoline engine in the dispense area.



TOXIC FLUID HAZARD

Hazardous fluid or toxic fumes can cause serious injury or death if splashed in the eyes or on the skin, inhaled, or swallowed.

- Know the specific hazards of the fluid you are using.
- Store hazardous fluid in an approved container. Dispose of hazardous fluid according to all local, state and national guidelines.
- Always wear protective eyewear, gloves, clothing and respirator as recommended by the fluid and solvent manufacturer.
- Use the optional vent hood kit when pumping hazardous fluids.

Installation

Grounding

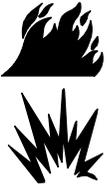
⚠ WARNING	
	FIRE AND EXPLOSION HAZARD Before operating the pump, ground the system as explained below. Also read the section FIRE AND EXPLOSION HAZARD on page 4.

1. *Pump*: the pump is grounded with a wire connecting the pump from the control enclosure. Locate the small hole (W) in the pump outlet housing. See Fig. 1. Attach the ground wire (Y) to the pump outlet housing using the ground screw (X) supplied with your system. Tighten the ground screw securely. Do not operate the equipment without the ground wire in place.
2. *Air compressor*: follow manufacturer's recommendations.
3. *Spray gun/dispense valve*: ground through connection to a properly grounded fluid hose and pump.
4. *Fluid supply container*: follow your local code.
5. *Object being dispensed to*: follow your local code.

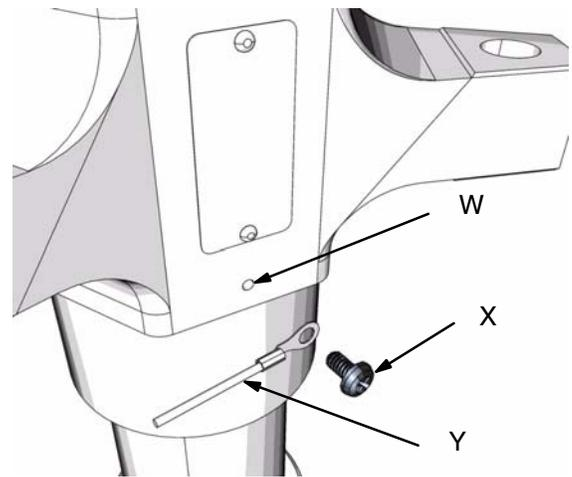

Fig. 1

T18154

Installation

Connecting the Displacement Pump to a Graco Air Motor

The displacement pump may be installed on **Senator, Bull, and King** Graco air motors using Connection Kit C03510 which can be purchased separately. Fig. 2 illustrates the displacement pump being installed on an NXT™ air motor.

1. Screw the tie rods (A) into the base of the air motor (B). Torque to 68–81 N.m (50–60 ft-lb).
2. Make sure the coupling nut (C) and the coupling collars (D) are in place on the pump displacement rod (1).
3. Use at least two people to hold the displacement pump (G) while another connects it to the motor (B). Orient the pump's fluid outlet (E) to the air inlet (F) as shown. Position the displacement pump (G) on the tie rods (A).
4. Screw the nuts (H) onto the tie rods (A) and torque to 61–81 N.m (50–60 ft-lb).
5. Screw the coupling nut (C) onto the motor shaft (J) loosely. Hold the motor shaft flats with a wrench to keep it from turning. Use an adjustable wrench to tighten the coupling nut. Torque to 196–210 N.m (145–155 ft-lb).
6. Replace the motor mount brackets (K) onto the motor.
7. Connect all hoses. Connect the ground wire (see page 5). Fill the wet-cup (2) 1/3 full of Graco Throat Seal Liquid or compatible fluid.
8. If there is material already in the pump, you must warm up the system for 30–60 minutes before running the pump. Be sure to open the gun before heating the system.
9. Turn on the air supply. Run the pump slowly to ensure proper operation.

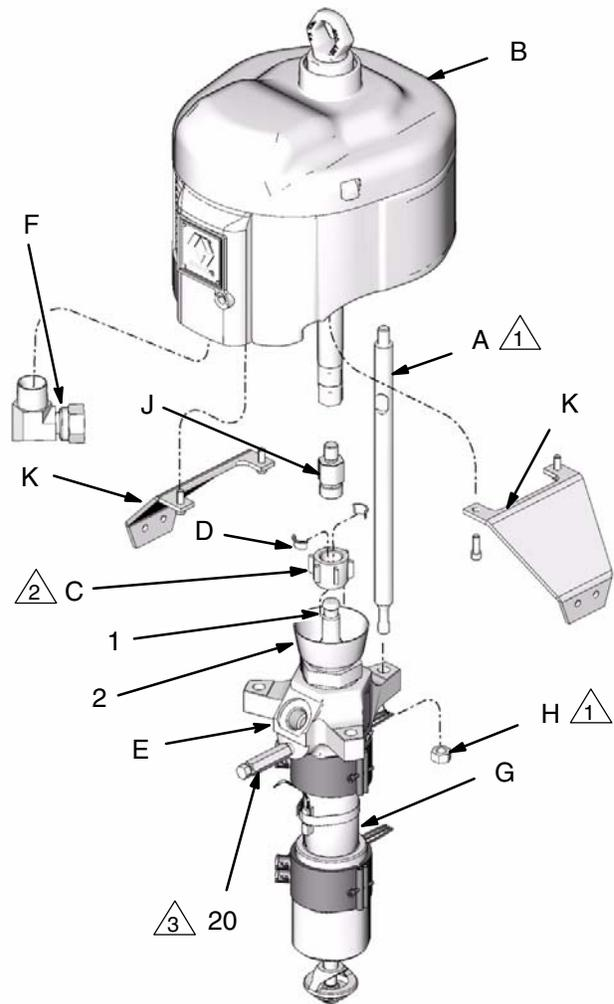

T18132

- △1 Torque to 61–81 N.m (50–60 ft-lb).
- △2 Torque to 196–210 N.m (145–155 ft-lb).
- △3 Bleed hole must face down.

Fig. 2

Operation/Maintenance

Pressure Relief Procedure

WARNING



INJECTION HAZARD

The system pressure must be manually relieved to prevent the system from starting or dispensing accidentally. Fluid under high pressure can be injected through the skin and cause serious injury. To reduce the risk of an injury from injection, splashing fluid, or moving parts, follow the **Pressure Relief Procedure** whenever you:

- are instructed to relieve the pressure,
- stop spraying/dispensing,
- check or service any of the system equipment,
- or install or clean the spray tip/nozzle.

WARNING



HOT SURFACE AND FLUID HAZARD

Heated fluid can cause severe burns and can cause equipment surfaces to become very hot. Wear protective gloves and clothing when operating this equipment in a heated system. Allow the equipment to cool thoroughly before servicing.

1. Lock the gun/valve trigger safety.
2. Close all air bleed valves (required in your system) to shut off the air supply to the pump.
3. Unlock the gun/valve trigger safety.
4. Hold a metal part of the gun/valve firmly to the side of a grounded metal pail, and trigger the gun/valve to relieve pressure.
5. Lock the gun/valve trigger safety.
6. Open the pump bleeder valve (required in your system), having a container ready to catch the drainage.
7. Leave the pump bleeder valve open until you are ready to spray/dispense again.

If you suspect that the spray tip/nozzle or hose is completely clogged, or that pressure has not been fully relieved after following the steps above, very slowly loosen the tip retaining nut or hose end coupling and relieve pressure gradually, then loosen completely. Now clear the tip/nozzle or hose.

Pump Startup, Adjustment, and Shutdown Instructions

Refer to your separate system manual to start, adjust, and shutdown the pump.

Service

Required Tools

- Torque wrench
- Bench vise, with soft jaws
- Rubber mallet
- Hammer
- O-ring pick
- 13 mm (1/2 in.) dia. brass rod
- Set of socket wrenches
- Set of adjustable wrenches
- Pipe wrench
- Screwdriver
- Heat gun
- Gloves
- Thread lubricant
- Thread sealant

Disconnecting the Displacement Pump

NOTE: The priming piston can be serviced without disconnecting the displacement pump from the motor. See page 9.

1. Flush the pump, if possible. Stop the pump at the bottom of its stroke, to prevent fluid from drying on the exposed displacement rod.

WARNING

To reduce the risk of serious injury whenever you are instructed to relieve pressure, always follow the **Pressure Relief Procedure** on page 7.

2. **Relieve the pressure.**

WARNING



HOT SURFACE AND FLUID HAZARD

Heated fluid can cause severe burns and can cause equipment surfaces to become very hot. Wear protective gloves and clothing when operating this equipment in a heated system. Allow the equipment to cool thoroughly before servicing.

3. Allow the pump to cool if being used in a heated system.

NOTE: It may be necessary to use a heat gun to ease disassembly of some parts.

4. Disconnect the air and fluid hoses.
5. Disconnect the pump from the heated platen.
6. Disconnect the displacement pump from the motor as explained in your separate system manual.

CAUTION

Be sure to use *at least* two people when lifting, moving, or disconnecting the pump. This pump is too heavy for one person. If you are disconnecting the displacement pump from a motor which is still mounted (for example, on a ram), *be sure* to support the displacement pump while it is being disconnected, to prevent it from falling and causing injury or property damage. Do this by securely bracing the pump, or by having at least two people hold it while another disconnects it.

NOTE: When disassembling the pump, lay out all the removed parts in sequence, to ease reassembly. Clean all parts with a compatible solvent and inspect them for wear or damage. Refer to Fig. 7 for a cutaway view of the pump.

Service

Servicing the Throat Packings

NOTE: The throat packings are available as a preassembled, pre-lubricated kit. See table below for Throat Seal Repair Kits.

Pump Part No.	Pump Series	Throat Seal Repair Kit	Kit Series
237795	A	237905	A
237795	B	241782	A
237795	C	241782	B
237885	A	237905	A
237885	B	241782	A
237885	C	241782	B
253141	A	253545	A
253141	B	253545	B

⚠ WARNING

To reduce the risk of serious injury whenever you are instructed to relieve pressure, always follow the **Pressure Relief Procedure** on page 7.

1. **Relieve the pressure.**
2. See Fig. 3. Unscrew the packing nut (2) using a pipe wrench. Remove the o-ring (6) and washer (47) from the bottom of the packing housing (3) or from the outlet housing (9).

1 Torque to 305 ± 14 N.m (225 ± 10 ft-lb).

2 Torque to 203 ± 41 N.m (150 ± 30 ft-lb).

3 Lips of u-cup packing must face down.

3. Place the flats of the packing nut (2) in a vise. Unscrew the packing housing (3) and discard it and the packings. Remove the washer (46), seal (5), and backup washer (45) from the packing nut.
4. The throat repair kit is preassembled. Screw the kit into the packing nut (2), making sure that the backup washer (45*), seal (5*), and washer (46*) are properly positioned on top of the packing housing (3*), with the lips of the seal facing down. Torque the packing housing (3*) to 305 ± 14 N.m (225 ± 10 ft-lb). See Fig. 3.
5. Remove o-ring (6*) from packing housing (3*) and lubricate with grease included with throat seal repair kit. This will keep the o-ring in place during installation. Install o-ring in packing housing .
6. **For Pump 253141 only:** Before installing packing housing into pump, generously pack grease zone region (46*) with high temperature grease supplied with repair kit.
7. Ensure washer (47*) and o-ring (6*) are properly installed on the bottom of the packing housing (3*).
8. Screw the packing nut (2) and packing housing (3*) into the outlet housing (9). Torque to 203 ± 41 N.m (150 ± 30 ft-lb).

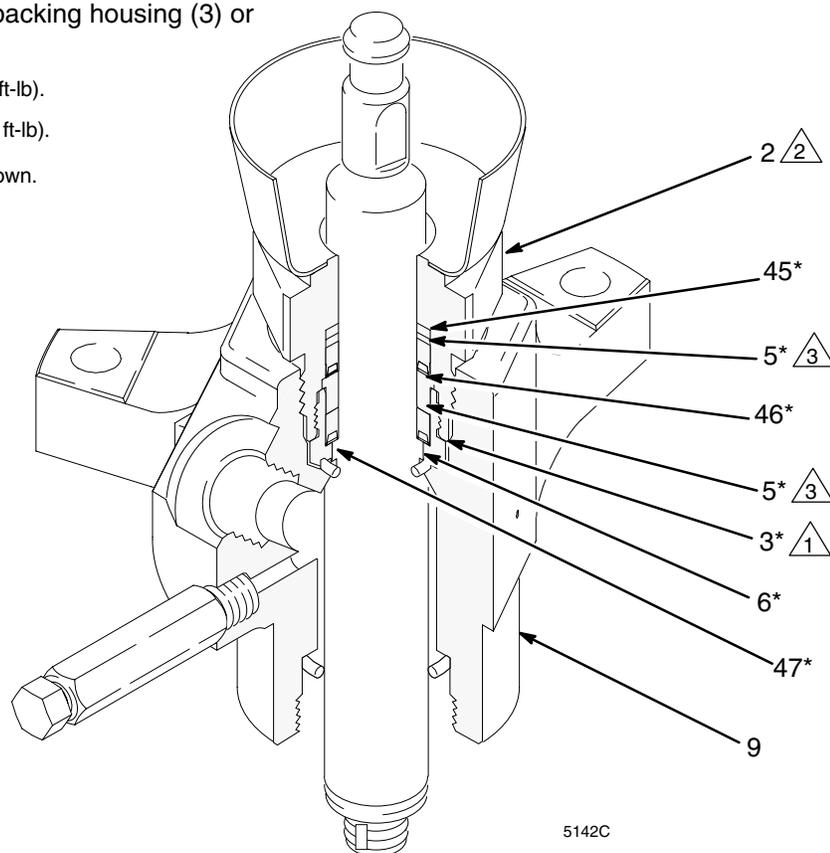

Fig. 3

5142C

Service

Servicing the Priming Piston

NOTE: The priming piston and the seat are a matched set. If either part needs replacement, replace both. See the table below for Priming Piston Repair Kits.

Pump Part No.	Priming Piston Repair Kit Part No.
237795	237909
253141	237907
237885	237910

1. Stop the pump on the downstroke, with the flats of the priming piston rod (18) exposed below the intake cylinder (19). It is not necessary to disconnect the displacement pump from the motor, but you may have to disconnect it from the heated platen.

! WARNING

To reduce the risk of serious injury whenever you are instructed to relieve pressure, always follow the **Pressure Relief Procedure** on page 7.

2. Relieve the pressure.
3. Hold the flats of the priming piston rod (18) with an adjustable wrench, and use a second wrench to unscrew the priming piston seat (22) from the rod. Slide the priming piston (21) off the rod. Inspect the inner and outer surfaces of the piston (21) for scoring, wear, or other damage.
4. Slide the priming piston (21☆) onto the rod (18) until it stops. Hold the rod (18) steady with a wrench on the flats, and screw the seat (22☆) onto the rod with another wrench. Torque to 81 ± 4 N.m (60 ± 3 ft-lb). See Fig. 4.

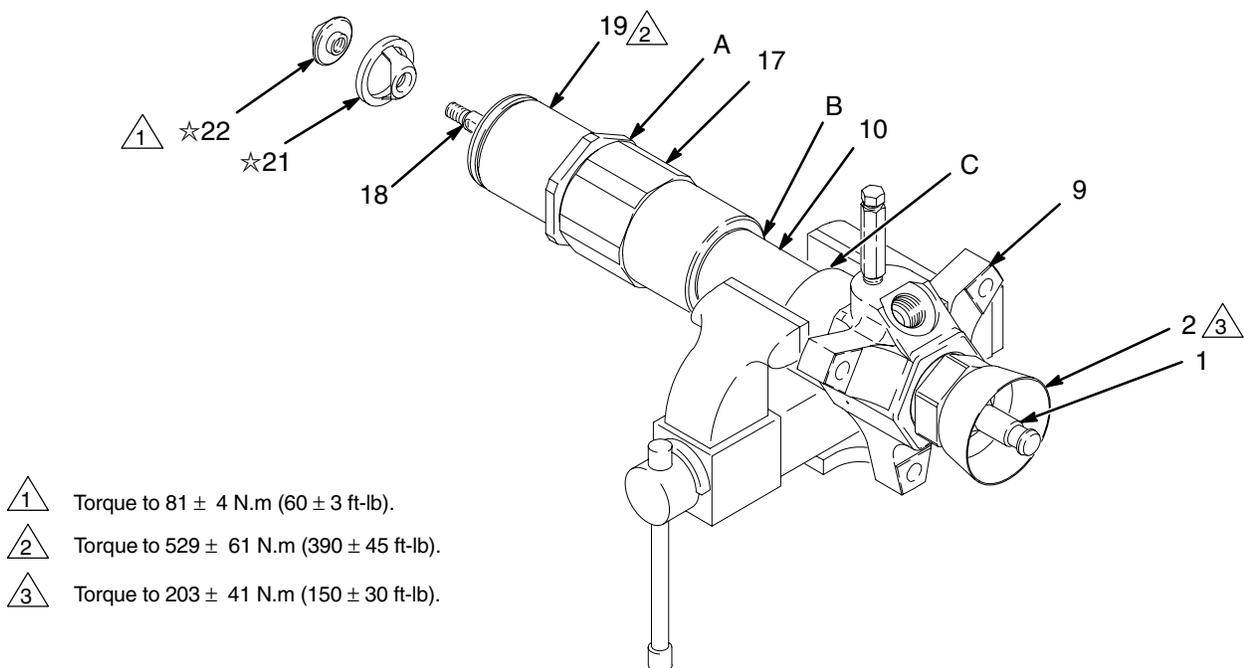

1 Torque to 81 ± 4 N.m (60 ± 3 ft-lb).

2 Torque to 529 ± 61 N.m (390 ± 45 ft-lb).

3 Torque to 203 ± 41 N.m (150 ± 30 ft-lb).

Fig. 4

05140

Service

Servicing the Intake Valve

NOTE: The intake valve (V) is available as a preassembled, pre-lubricated kit. The kit includes the valve and all seals and packings, and also includes the intake valve seat (36) and seal (37). See the table below for a list of Intake valve repair Kit Part Nos.

Displacement Pump Part Nos	Intake valve Repair Kit Part Nos.
253141	253546
237795	237907
237885	237907

Disassembly

WARNING

To reduce the risk of serious injury whenever you are instructed to relieve pressure, always follow the **Pressure Relief Procedure** on page 7.

1. **Relieve the pressure.**
2. Disconnect the displacement pump as explained in your separate system manual.
3. Place the pump in a vise, with the outlet housing (9) positioned as shown in Fig. 4 on page 11.

4. Remove the priming piston (21) as explained on page 11.
5. Using a pipe wrench on the hex of the intake cylinder (19), unscrew it from the intake housing (17). The pump may separate at joints A, B, or C.

NOTE: These instructions are written with the pump separating at joint A. If it separates at joints B or C, disassemble it at that joint, place the intake housing (17) in a vise, and continue with step 6.

6. Unscrew the intake housing (17) from the cylinder (10). Pull the housing off the pump. The intake check valve assembly (V, see Fig. 5) should slide down the priming piston rod (18) as you remove the housing; if it does not slide easily, firmly tap on the top of the housing (17) with a rubber mallet to loosen.
7. Pull the intake seat (36) and seal (37) out the bottom of the intake housing (17). Take care not to drop the valve assembly (V) as it comes free. See Fig. 5.

NOTE: If the seat (36) is difficult to remove, insert a brass rod through the top of the housing (17) and drive the seat out with a hammer.

8. To service the piston, cylinder, seals, and rods, go to **Servicing the Piston** on page 14.

Service

Reassembly

1. Slide the intake housing (17) onto the priming piston rod (18), making certain that the smooth surface of the valve stop (VS) is facing down toward the pump intake. Screw the housing (17) onto the cylinder (10). See Figs. 5 and 6.
2. Lubricate the priming piston rod (18), then slide the preassembled intake valve (V‡) onto the rod, making certain that the packing nut (15‡) goes on the rod first. Push the valve assembly up the rod as far as possible. Use a rubber mallet on the priming piston rod (18), to drive the valve assembly up to the stop (VS). See Figs. 5 and 6.
3. The intake seat (36‡) is reversible. Push it into the housing (17) until it seats securely. Lubricate the seal (37‡) and install in the bevel around the bottom of the seat. See Fig. 5.
4. Screw the intake cylinder (19) into the intake housing (17). Using a pipe wrench on the hex of the cylinder (19), torque the cylinder to 522–542 N.m (385–400 ft-lb). This will also torque the intake housing (17) and pump cylinder (10) into the outlet housing (9). See Fig. 4 on page 11.
5. Replace the priming piston (21☆) and seat (22☆) as explained on page 11.
6. Reconnect the displacement pump to the air motor as explained in your separate system manual.

- △1 Lubricate.
- △2 Lips of u-cup seal and v-packings must face up.
- △3 Torque to 97–106 N.m (71–78 ft-lb).

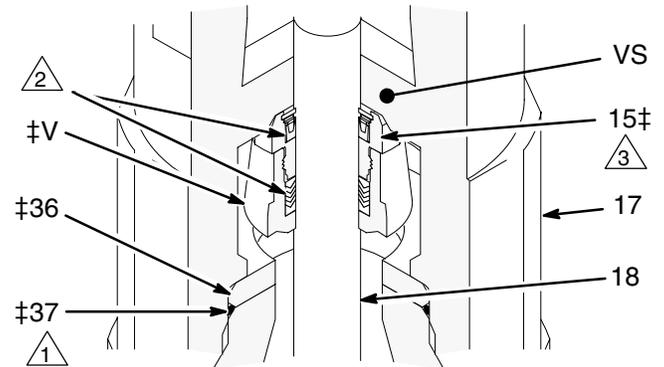

Fig. 5

05142

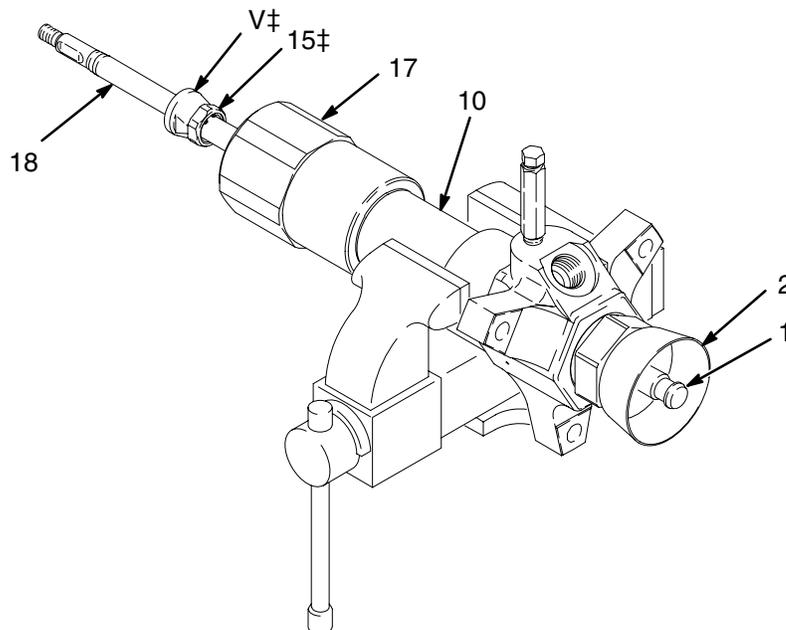

Fig. 6

05141

Service

Servicing the Piston

NOTE: The piston valve is available as a preassembled, pre-lubricated kit. The kit includes the piston seat/guide assembly (P, items 11, 13, and 14), piston (12), and two cylinder seals (8). Order Part No. 237906. Parts included in this kit are marked with a symbol, for example (8†).

Disassembly

1. Disassemble the pump as explained under **Servicing the Intake Valve** on page 12.
2. Using a rubber mallet, drive the displacement rod (1) and the priming piston rod (18) out of the outlet housing (9) and cylinder (10). Inspect the outer surfaces of the rods for damage by running a finger over the surface.
3. Remove the seal (8) from the bottom of the cylinder (10). See Fig. 7. Shine a light into the cylinder to examine the inside surface for scoring or damage. **Only if the cylinder is damaged, or there is evidence of leaking around the top cylinder seal (8),** unscrew the cylinder from the outlet housing, using a pipe wrench. Remove the top cylinder seal.
4. Place the flats of the displacement rod (1) in a vise. Unscrew the piston (12) from the displacement rod; the priming piston rod (18) will come with it. Slide the piston seat/guide assembly (P, items 11, 13, and 14) off the piston (12).
5. Place the piston (12) flats in a vise and unscrew the rod (18).

Reassembly

1. Place the preassembled piston seat/guide assembly (P†, items 11, 13, and 14) onto the piston (12†) so the 45° beveled seating surfaces match.
2. Place the flats of the displacement rod (1) in a vise. Screw the piston (12†) onto the displacement rod (1) hand tight, then torque to 339–359 N.m (250–265 ft-lb).
3. Using an adjustable wrench on the flats of the priming piston rod (18), screw the rod into the piston. Torque to 125–137 N.m (92–101 ft-lb). Be careful not to create burrs on the flats of the rod.
4. If the cylinder (10) was removed from the outlet housing (9), lubricate the seal (8†) and place it on the top of the cylinder. (The cylinder is symmetrical, so either end can be the top.) Screw the cylinder into the outlet housing. See Fig. 7.
5. Lubricate the displacement rod (1). Slide the rod, piston assembly, and priming piston rod (18) into the cylinder (10) from the bottom, until the top of the rod (1) protrudes from the packing nut (2).
6. Lubricate the seal (8†) and install it on the bottom of the cylinder (10).
7. Continue with **Reassembly** under **Servicing the Intake Valve** on page 13.

Service

- △1 Piston check valve (see Detail below).
- △2 Throat packings (see Fig. 3).
- △3 Intake check valve (see Fig. 5).
- △4 Lubricate.
- △5 Torque to 190–217 N.m (140–160 ft-lb).
- △6 Torque to 522–542 N.m (385–400 ft-lb).
- △7 Torque to 125–137 N.m (92–101 ft-lb).
- △8 Torque to 75–88 N.m (55–65 ft-lb).
- △9 Torque to 339–359 N.m (250–265 ft-lb).

DETAIL OF PISTON CHECK VALVE

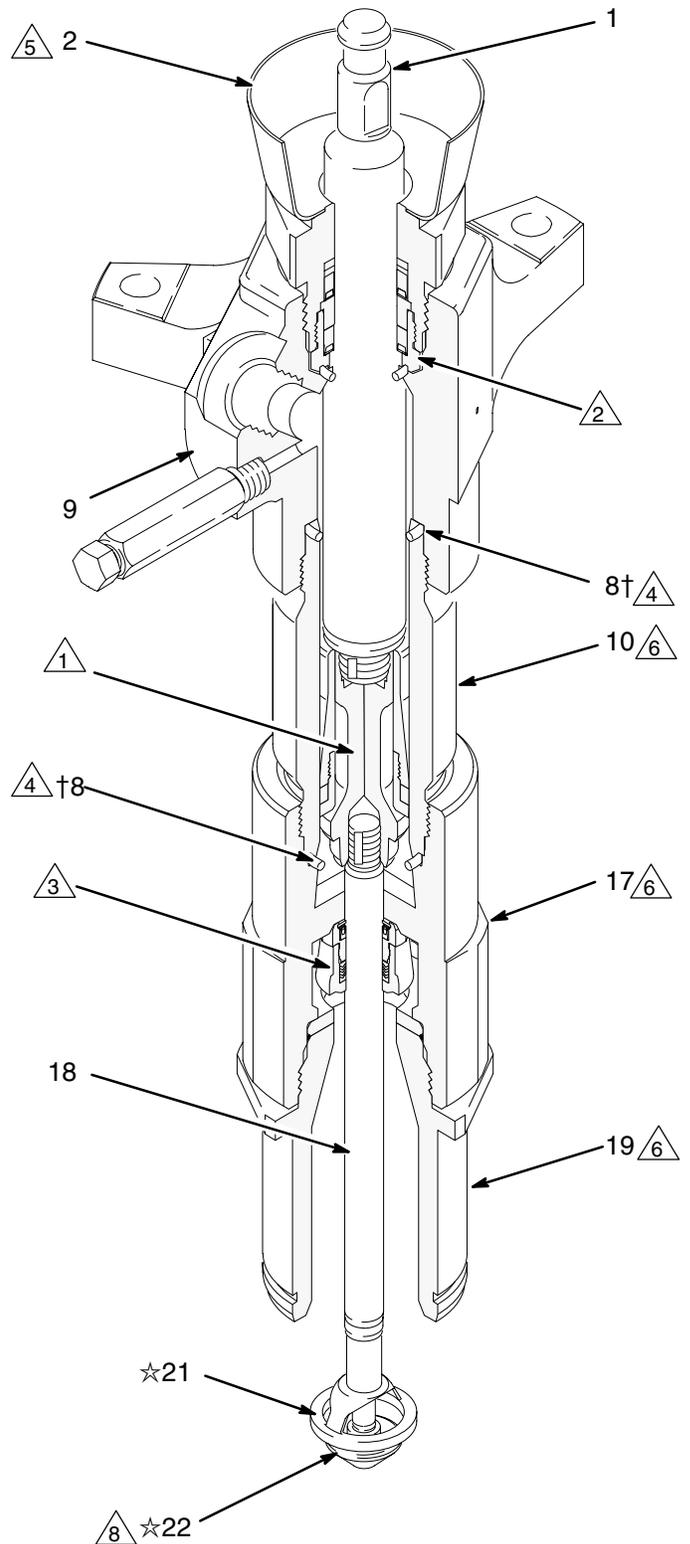
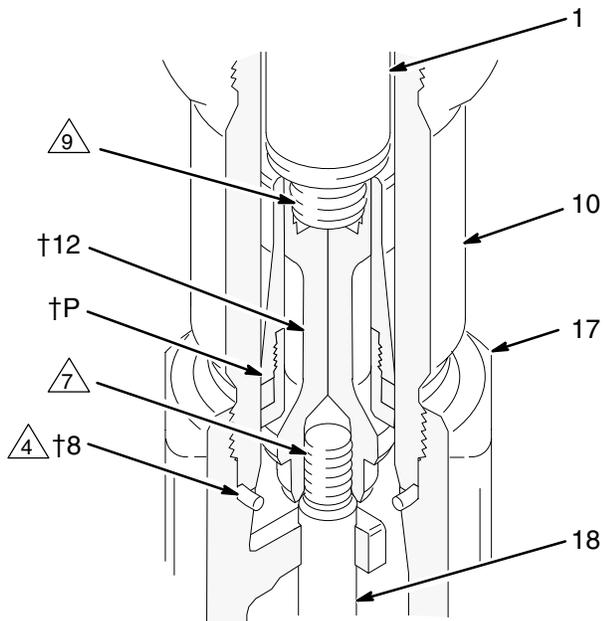

Fig. 7

5142C

Parts

Part No. 237795, Series C, 55 Gallon (200 Liter) Drum Size Displacement Pump

Ref No.	Part No.	Description	Qty	Ref No.	Part No.	Description	Qty
1	189317	ROD, displacement; stainless steel	1	26‡		RING, retaining; carbon steel	1
2	237799	PACKING NUT/WET-CUP; carbon steel	1	30▲	172479	TAG, warning (not shown)	1
3*	190585	HOUSING, throat seal; carbon steel	1	36‡	189446	SEAT, intake valve; chrome plated stainless steel	1
5*	113021	SEAL, u-cup, throat; PTFE with stainless steel spring	2	37‡	113041	SEAL, intake; Fluoroelastomer	1
6*	106258	O-RING; Fluoroelastomer	1	38	101754	PLUG, pipe; 3/8 npt	1
8†	113040	SEAL, cylinder; Fluoroelastomer	2	39	109482	SEAL, intake valve; Fluoroelast- omer	1
9	237894	HOUSING, outlet; ductile iron	1	43‡	109301	V-PACKING; PTFE	4
10	189437	CYLINDER, pump; stainless steel	1	44‡	184196	GLAND, female; carbon steel	1
11†	189438	GUIDE, piston; stainless steel	1	45*	19Y496	WASHER, seal backup	1
12†	189439	PISTON; stainless steel	1	46*	19Y497	WASHER, scraper	1
13†	113355	BEARING, piston; bronze-filled PTFE	1	47*	19Y495	WASHER, rod scraper	1
14†	189441	SEAT, piston; stainless steel	1	* These parts are included in Throat Repair Kit 241782, which may be purchased separately. For Series A pumps, use Throat Repair Kit 237905, which includes items 3, 5 (qty.: 1), 6, and 47.			
15‡	190762	NUT, packing, intake valve; carbon steel	1	☞ To convert a Series A single throat packing pump to a Series B dual throat packing pump, order Throat Repair Kit 241782 and a new Packing Nut 237799.			
16‡	189514	VALVE BODY, intake; chrome plated stainless steel	1	† These parts are included in Piston Repair Kit 237906, which may be purchased separately.			
17	237895	HOUSING, intake; ductile iron	1	‡ These parts are included in Intake Valve Repair Kit 237907, which may be purchased separately.			
18	184400	ROD, priming piston; stainless steel	1	☆ These parts are included in Priming Piston Repair Kit 237909, which may be purchased separately.			
19	190586	CYLINDER, intake; carbon steel	1	▲ Replacement Danger and Warning labels, tags and cards are available at no cost.			
20	237908	BLEEDER VALVE KIT; carbon steel	1				
21☆	276378	PISTON, priming; stainless steel	1				
22☆	190241	SEAT, priming piston; stainless steel	1				
23‡	184246	GLAND, male; carbon steel	1				
24‡	113020	SEAL, u-cup, intake valve; PTFE with stainless steel spring	1				
25‡	190523	WASHER, retainer; stainless steel	1				

Parts

Part No. 237795, Series C, 55 Gallon (200 Liter) Drum Size Displacement Pump

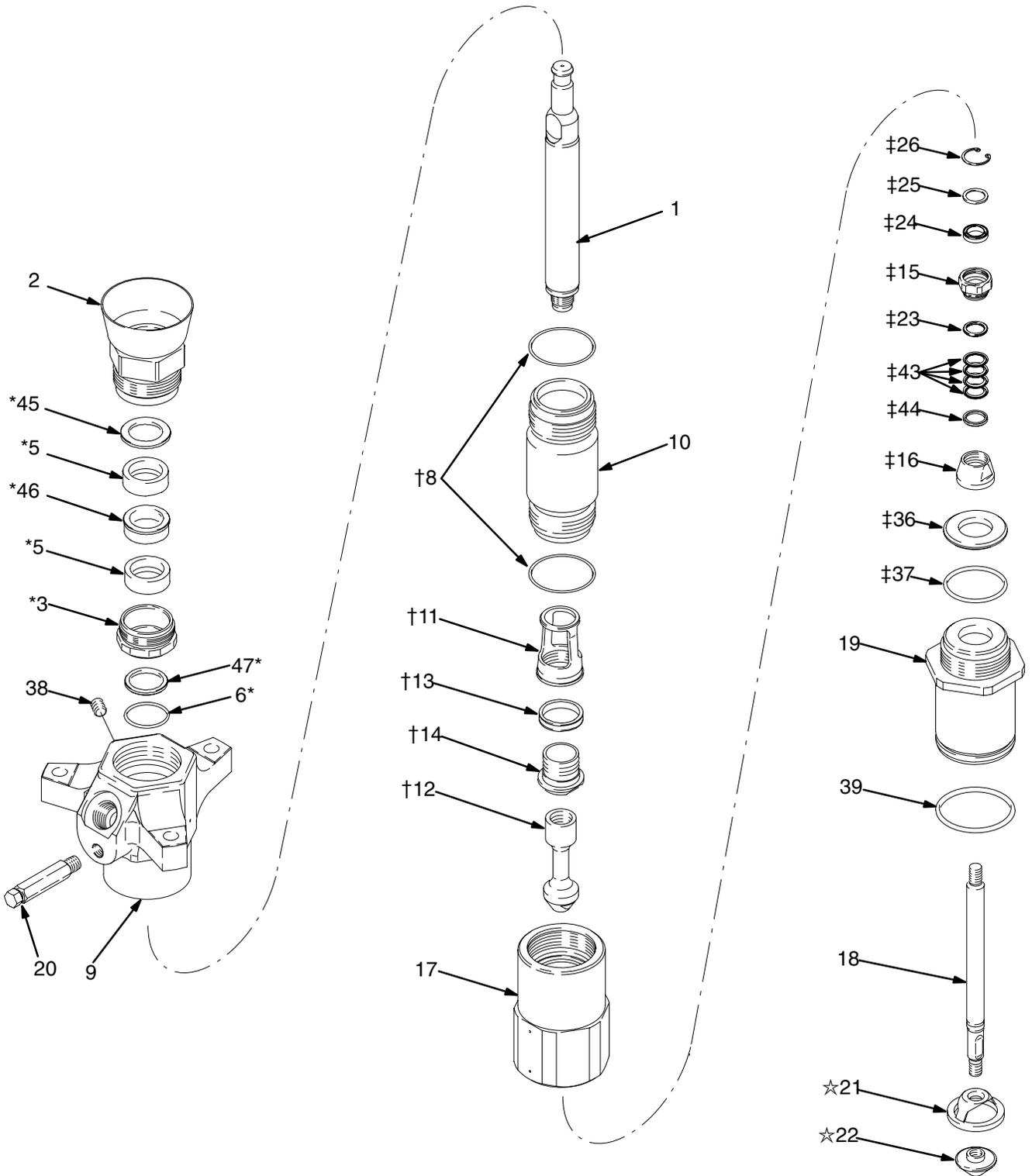

05136C

Parts

Part No. 237885, Series C, 5 Gallon (19 Liter) Pail Size Displacement Pump

Ref No.	Part No.	Description	Qty	Ref No.	Part No.	Description	Qty
1	189317	ROD, displacement; stainless steel	1	36‡	189446	SEAT, intake valve; chrome plated stainless steel	1
2	237799	PACKING NUT/WET-CUP; carbon steel	1	37‡	113041	SEAL, intake; Fluoroelastomer	1
3*	190585	HOUSING, throat seal; carbon steel	1	38	101754	PLUG, pipe; 3/8 npt	1
5*	113021	SEAL, u-cup, throat; PTFE with stainless steel spring	2	39	113054	SEAL, intake valve; Fluoroelastomer	1
6*	106258	O-RING; Fluoroelastomer	1	40	190620	FLANGE; carbon steel	1
8†	113040	SEAL, cylinder; Fluoroelastomer	2	43‡	109301	V-PACKING; PTFE	4
9	237894	HOUSING, outlet; ductile iron	1	44‡	184196	GLAND, female; carbon steel	1
10	189437	CYLINDER, pump; stainless steel	1	45*	19Y496	WASHER, seal backup	1
11†	189438	GUIDE, piston; stainless steel	1	46*	19Y497	WASHER, scraper	1
12†	189439	PISTON; stainless steel	1	47*	19Y495	WASHER, rod scraper	1
13†	113355	BEARING, piston; bronze-filled PTFE	1	* These parts are included in Throat Repair Kit 241782, which may be purchased separately. For Series A pumps, use Throat Repair Kit 237905, which includes items 3, 5 (qty.: 1), 6, and 47.			
14†	189441	SEAT, piston; stainless steel	1	☞ To convert a Series A single throat packing pump to a Series B dual throat packing pump, order Throat Repair Kit 241782 and a new Packing Nut 237799.			
15‡	190762	NUT, packing, intake valve; carbon steel	1	* These parts are included in Throat Repair Kit 237905, which may be purchased separately.			
16‡	189514	VALVE BODY, intake; chrome plated stainless steel	1	† These parts are included in Piston Repair Kit 237906, which may be purchased separately.			
17	237895	HOUSING, intake; ductile iron	1	‡ These parts are included in Intake Valve Repair Kit 237907, which may be purchased separately.			
18	184400	ROD, priming piston; stainless steel	1	☆ These parts are included in Priming Piston Repair Kit 237910, which may be purchased separately.			
19	190608	CYLINDER, intake; carbon steel	1	▲ Replacement Danger and Warning labels, tags and cards are available at no cost.			
20	237908	BLEEDER VALVE KIT; carbon steel	1				
21☆	190606	PISTON, priming; carbon steel	1				
22☆	190607	SEAT, priming piston; carbon steel	1				
23‡	184246	GLAND, male; carbon steel	1				
24‡	113020	SEAL, u-cup, intake valve; PTFE with stainless steel spring	1				
25‡	190523	WASHER, retainer; stainless steel	1				
26‡		RING, retaining; carbon steel	1				
30▲	172479	TAG, warning (not shown)	1				

Parts

Part No. 237885, Series C, 5 Gallon (19 Liter) Pail Size Displacement Pump

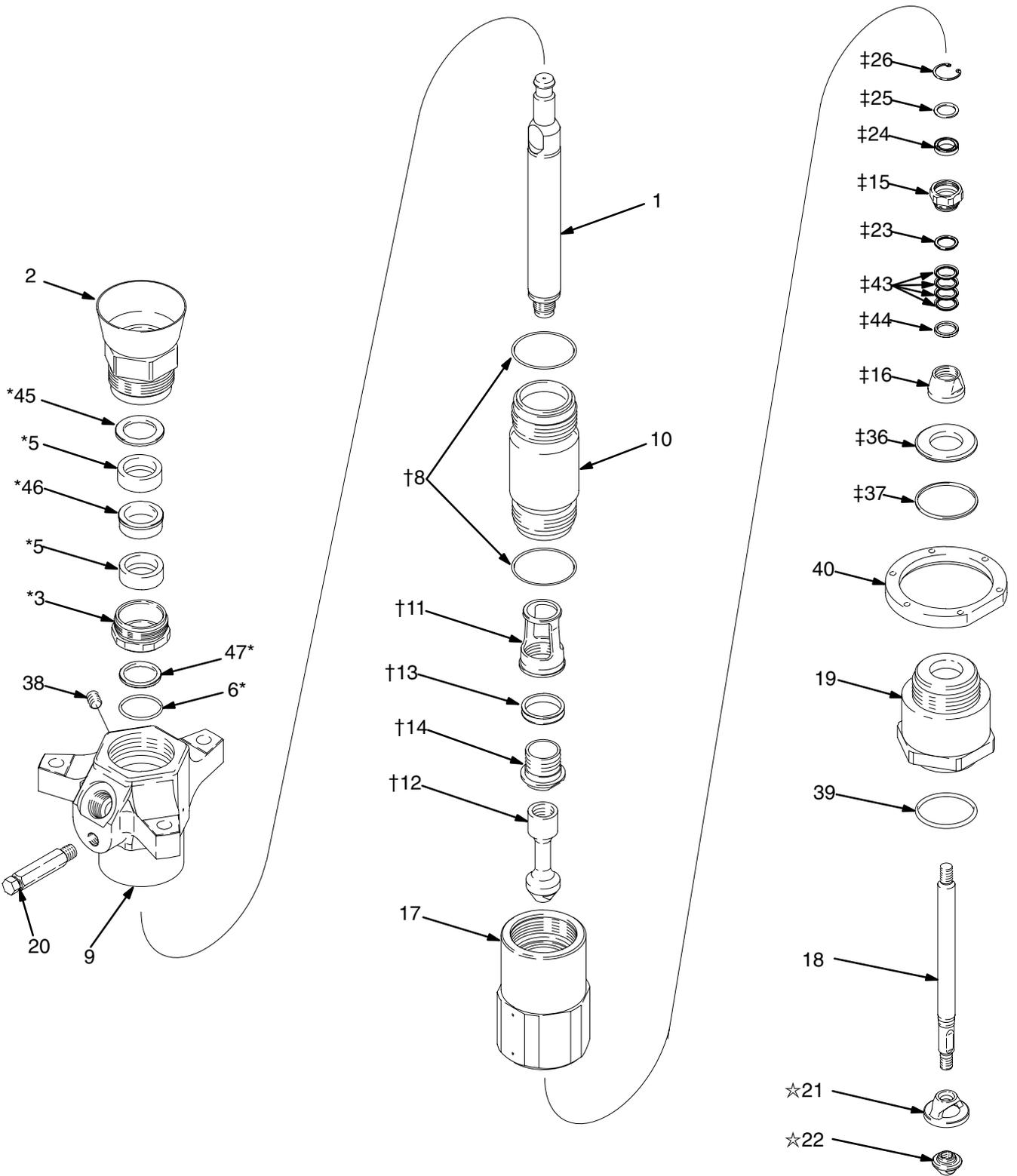

05138C

Parts

Part No. 253141, Series B, 55 Gallon (200 Liter) Drum Size Displacement Pump

Ref No.	Part No.	Description	Qty	Ref No.	Part No.	Description	Qty
1	189317	ROD, displacement	1	28▲	184090	LABEL, warning (not shown)	2
2	237799	NUT, packing	1	29‡	190126	BODY, bleeder	1
3*	190585	NUT, packing	1	36‡	189446	SEAT, valve	1
5*	120286	PACKING, u-cup	2	37‡	113041	PACKING, o-ring	1
6*	106258	PACKING, o-ring	1	38	101754	PLUG, pipe	1
8†	113040	PACKING, o-ring	2	39	109482	PACKING, o-ring	1
9	190598	HOUSING, outlet	1	43‡	109301	V-PACKING	4
10	189437	CYLINDER, pump	1	44‡	184196	GLAND, packing female	1
11†	189438	GUIDE, piston	1	45*	19Y496	WASHER, seal backup	1
12†	189439	SEAT, piston SST	1	46*	19Y498	WASHER, scraper grease zone	1
13†	113355	BEARING, piston	1	47*	19Y495	WASHER, rod scraper	1
14†	189441	SEAT, piston	1				
15‡	190762	NUT, seal	1				
16‡	189514	VALVE, intake	1				
17	190597	HOUSING, valve	1				
18	184400	ROD, piston	1				
19	190586	CYLINDER, intake	1				
20	190128	PLUG, valve	1				
21☆	276378	PISTON	1				
22☆	190241	SEAT, piston	1				
23‡	184246	GLAND, packing male	1				
24‡	120285	PACKING, u-cup	1				
25‡	190523	WASHER, retainer	1				
26‡		RING, retainer	1				
27‡	100508	SCREW, drive (not shown)	6				

* These parts are included in Throat Repair Kit 253545, which may be purchased separately.

† These parts are included in Piston Repair Kit 237906, which may be purchased separately.

‡ These parts are included in Intake Valve Repair Kit 253546, which may be purchased separately.

☆ These parts are included in Priming Piston Repair Kit 237909, which may be purchased separately.

▲ Replacement Danger and Warning labels, tags and cards are available at no cost.

Parts

Part No. 253141, Series B, 55 Gallon (200 Liter) Drum Size Displacement Pump

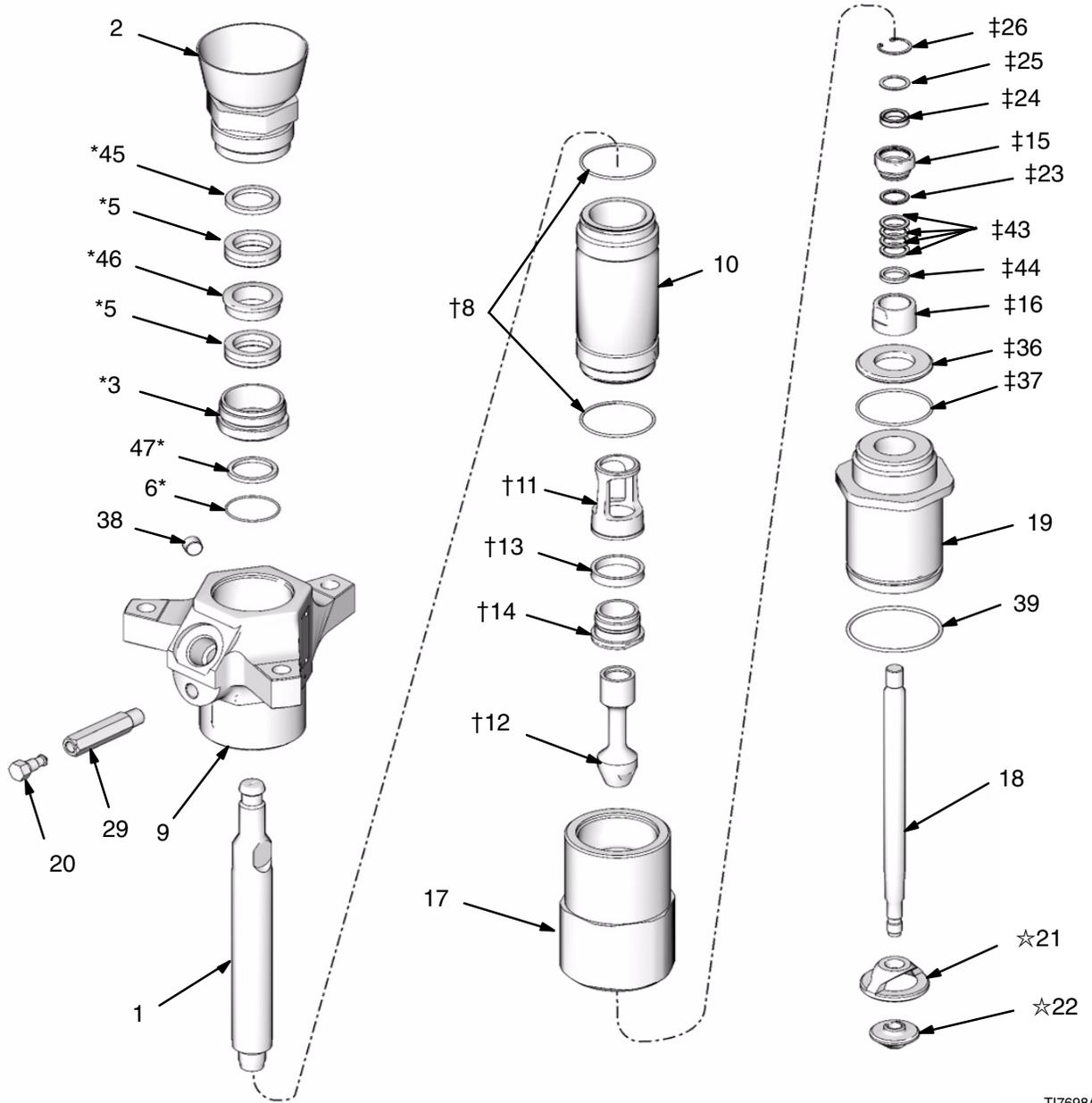

TI7698A

Technical Data

WARNING

Be sure that all fluids and solvents used are chemically compatible with the Wetted Parts listed below. Always read the manufacturer's literature before using fluid or solvent in this pump.

Category	Data
Maximum fluid working pressure	40 MPa, 403 bar (5850 psi)
Displacement pump effective area	8 cm ² (1.24 in. ²)
Maximum pump operating temperature	400°F (200°C)
Fluid outlet size	1" npt(f)
Weight	<i>Model 237795</i> : approx. 27 kg (59 lb) <i>Model 237885</i> : approx. 28 kg (61 lb) <i>Model 253141</i> : approx. 27 kg (59 lb)
Length	<i>On Upstroke</i> : 728.5 mm (28.68 in.) <i>On Downstroke (priming piston exposed)</i> : 793.7 mm (31.25 in.)
Wetted parts	Carbon Steel; Chrome, Zinc, and Nickel Plating; 304, 316, 440, and 17-4 PH Grades of Stainless Steel; Alloy Steel; Ductile Iron; Fluoroelastomer; PTFE, Bronze.

Graco Standard Warranty

Graco warrants all equipment manufactured by Graco and bearing its name to be free from defects in material and workmanship on the date of sale by an authorized Graco distributor to the original purchaser for use. With the exception of any special, extended, or limited warranty published by Graco, Graco will, for a period of twelve months from the date of sale, repair or replace any part of the equipment determined by Graco to be defective. This warranty applies only when the equipment is installed, operated and maintained in accordance with Graco's written recommendations.

This warranty does not cover, and Graco shall not be liable for general wear and tear, or any malfunction, damage or wear caused by faulty installation, misapplication, abrasion, corrosion, inadequate or improper maintenance, negligence, accident, tampering, or substitution of non-Graco component parts. Nor shall Graco be liable for malfunction, damage or wear caused by the incompatibility of Graco equipment with structures, accessories, equipment or materials not supplied by Graco, or the improper design, manufacture, installation, operation or maintenance of structures, accessories, equipment or materials not supplied by Graco.

This warranty is conditioned upon the prepaid return of the equipment claimed to be defective to an authorized Graco distributor for verification of the claimed defect. If the claimed defect is verified, Graco will repair or replace free of charge any defective parts. The equipment will be returned to the original purchaser transportation prepaid. If inspection of the equipment does not disclose any defect in material or workmanship, repairs will be made at a reasonable charge, which charges may include the costs of parts, labor, and transportation.

THIS WARRANTY IS EXCLUSIVE, AND IS IN LIEU OF ANY OTHER WARRANTIES, EXPRESS OR IMPLIED, INCLUDING BUT NOT LIMITED TO WARRANTY OF MERCHANTABILITY OR WARRANTY OF FITNESS FOR A PARTICULAR PURPOSE.

Graco's sole obligation and buyer's sole remedy for any breach of warranty shall be as set forth above. The buyer agrees that no other remedy (including, but not limited to, incidental or consequential damages for lost profits, lost sales, injury to person or property, or any other incidental or consequential loss) shall be available. Any action for breach of warranty must be brought within two (2) years of the date of sale.

Graco makes no warranty, and disclaims all implied warranties of merchantability and fitness for a particular purpose in connection with accessories, equipment, materials or components sold but not manufactured by Graco. These items sold, but not manufactured by Graco (such as electric motors, switches, hose, etc.), are subject to the warranty, if any, of their manufacturer. Graco will provide purchaser with reasonable assistance in making any claim for breach of these warranties.

In no event will Graco be liable for indirect, incidental, special or consequential damages resulting from Graco supplying equipment hereunder, or the furnishing, performance, or use of any products or other goods sold hereto, whether due to a breach of contract, breach of warranty, the negligence of Graco, or otherwise.

FOR GRACO CANADA CUSTOMERS

The parties acknowledge that they have required that the present document, as well as all documents, notices and legal proceedings entered into, given or instituted pursuant hereto or relating directly or indirectly hereto, be drawn up in English. Les parties reconnaissent avoir convenu que la rédaction du présente document sera en Anglais, ainsi que tous documents, avis et procédures judiciaires exécutés, donnés ou intentés à la suite de ou en rapport, directement ou indirectement, avec les procédures concernées.

Graco Information

For the latest information about Graco products, visit www.graco.com.

TO PLACE AN ORDER, contact your Graco distributor or call to identify the distributor closest to you:

Toll Free Phone Number: 1-800-328-0211

All written and visual data contained in this document reflects the latest product information available at the time of publication. Graco reserves the right to make changes at any time without notice.

Original instructions. This manual contains English. MM 308076

Graco Headquarters: Minneapolis
International Offices: Belgium, China, Japan, Korea

GRACO INC. AND SUBSIDIARIES • P.O. BOX 1441 • MINNEAPOLIS MN 55440-1441 • USA
Copyright 1995, Graco Inc. All Graco manufacturing locations are registered to ISO 9001.

www.graco.com
Revised H, March 2025