

**INSTRUCTIONS**

This manual contains important warnings and information.
READ AND RETAIN FOR REFERENCE



ELECTRIC, 120 VAC

Pro 301sts Airless Paint Sprayer

2750 psi (195 bar) Maximum Working Pressure

Model 231—344, Series A

Complete sprayer with hoses, gun, RAC IV® DripLess™
Tip Guard and SwitchTip™

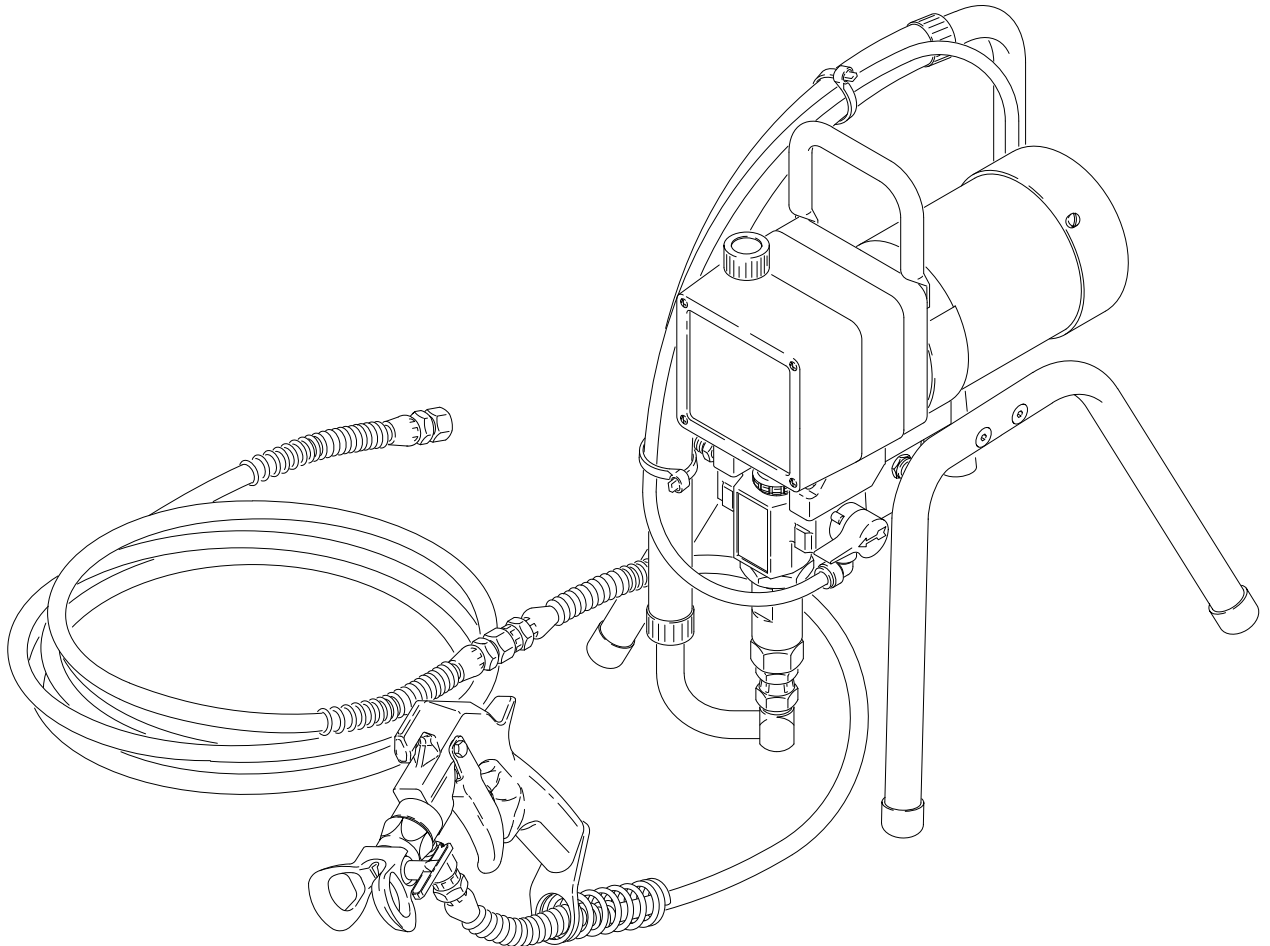

Table of Contents

Warnings	4	ON/OFF Switch	27
Major Components	5	Drive Housing, Connecting Rod, Crankshaft	28
Setup	6	Pressure Control	30
Operation	7	Pressure Transducer	31
Startup	9	Drain Valve	32
Shutdown and Care	12	Inlet Strainer Installation/Removal	32
Flushing	13	Displacement Pump Parts Drawing and List	33
Troubleshooting	14	Accessories	33
Motor Test	18	Sprayer Parts Drawing	34
General Repair Information	19	Sprayer Parts List	35
Motor Brush	20	Technical Data	36
Displacement Pump Repair	22	Dimensions	36
Motor	26	Graco Phone Numbers	36
Motor Start Board	27	Graco Warranty and Disclaimers	36
Power Supply Cord	27		

Symbols

Warning Symbol



This symbol alerts you to the possibility of serious injury or death if you do not follow the instructions.

Caution Symbol



This symbol alerts you to the possibility of damage to or destruction of equipment if you do not follow the instructions.

! WARNING



FIRE AND EXPLOSION HAZARD

Improper grounding, poor ventilation, open flames or sparks can cause a hazardous condition and result in a fire or explosion and serious injury.

- If there is any static sparking or you feel an electric shock while using this equipment, **stop spraying immediately**. Do not use the equipment until you identify and correct the problem.
- Provide fresh air ventilation to avoid the buildup of flammable fumes from solvents or the fluid being sprayed.
- Keep the spray area free of debris, including solvent, rags, and gasoline.
- Electrically disconnect all equipment in the spray area.
- Extinguish all open flames or pilot lights in the spray area.
- Do not smoke in the spray area.
- Do not turn on or off any light switch in the spray area while operating or if fumes are present.
- Do not operate a gasoline engine in the spray area.

WARNING



INJECTION HAZARD

Spray from the gun, leaks or ruptured components can inject fluid into your body and cause extremely serious injury, including the need for amputation. Fluid splashed in the eyes or on the skin can also cause serious injury.

- Fluid injected into the skin is a serious injury. The injury may look like just a cut, but it is a serious injury. Get immediate medical attention.
- Do not point the gun at anyone or at any part of the body.
- Do not put your hand or fingers over the spray tip.
- Do not stop or deflect leaks with your hand, body, glove or rag.
- Do not “blow back” fluid; this is not an air spray system.
- Always have the tip guard and the trigger guard on the gun when spraying.
- Check the gun diffuser operation weekly. Refer to the gun manual.
- Be sure the gun trigger safety operates before spraying.
- Lock the gun trigger safety when you stop spraying.
- Follow the **Pressure Relief Procedure** on page 9 if the spray tip clogs and before cleaning, checking or servicing the equipment.
- Tighten all fluid connections before operating the equipment.
- Check the hoses, tubes, and couplings daily. Replace worn or damaged parts immediately. Do not repair high pressure couplings; you must replace the entire hose.
- Fluid hoses must have spring guards on both ends, to help protect them from rupture caused by kinks or bends near the couplings.



TOXIC FLUID HAZARD

Hazardous fluid or toxic fumes can cause serious injury or death if splashed in the eyes or on the skin, inhaled, or swallowed.

- Know the specific hazards of the fluid you are using.
- Store hazardous fluid in an approved container. Dispose of hazardous fluid according to all local, state and national guidelines.
- Always wear protective eyewear, gloves, clothing and respirator as recommended by the fluid and solvent manufacturer.



MOVING PARTS HAZARD

Moving parts can pinch or amputate your fingers.

- Keep clear of all moving parts when starting or operating the pump.
- Before servicing the equipment, follow the **Pressure Relief Procedure** on page 9 to prevent the equipment from starting unexpectedly.

⚠ WARNING



INSTRUCTIONS

EQUIPMENT MISUSE HAZARD

Equipment misuse can cause the equipment to rupture or malfunction and result in serious injury.

- This equipment is for professional use only.
- Read all instruction manuals, tags, and labels before operating the equipment.
- Use the equipment only for its intended purpose. If you are not sure, call Graco Technical Assistance at 1-800-543-0339.
- Do not alter or modify this equipment.
- Check equipment daily. Repair or replace worn or damaged parts immediately.
- Do not exceed the maximum working pressure of the lowest rated system component. Refer to the **Technical Data** on page 36 for the maximum working pressure of this equipment.
- Use fluids and solvents which are compatible with the equipment wetted parts. Refer to the **Technical Data** section of all equipment manuals. Read the fluid and solvent manufacturer's warnings.
- Do not use 1,1,1-trichloroethane, methylene chloride, other halogenated hydrocarbon solvents or fluids containing such solvents in pressurized aluminum equipment. Such use could result in a chemical reaction, with the possibility of explosion.
- Do not use hoses to pull equipment.
- Route hoses away from traffic areas, sharp edges, moving parts, and hot surfaces. Do not expose Graco hoses to temperatures above 82°C (180°F) or below -40°C (-40°F).
- Do not lift pressurized equipment.
- Comply with all applicable local, state, and national fire, electrical, and safety regulations.

NOTE: This is an example of the DANGER label on your sprayer. This label is available in other languages, free of charge. See page 36 to order.

⚠ DANGER ⚠			
	FIRE AND EXPLOSION HAZARD		SKIN INJECTION HAZARD
<p>Spray painting, flushing or cleaning equipment with flammable liquids in confined areas can result in fire or explosion.</p> <p>Use outdoors or in extremely well ventilated areas. Ground equipment, hoses, containers and objects being sprayed.</p> <p>Avoid all ignition sources such as static electricity from plastic drop cloths, open flames such as pilot lights, hot objects such as cigarettes, arcs from connecting or disconnecting power cords or turning light switches on and off.</p> <p>Failure to follow this warning can result in death or serious injury.</p>	<p>Liquids can be injected into the body by high pressure airless spray or leaks – especially hose leaks.</p> <p>Keep body clear of the nozzle. Never stop leaks with any part of the body. Drain all pressure before removing parts. Avoid accidental triggering of gun by always setting safety latch when not spraying.</p> <p>Never spray without a tip guard.</p> <p>In case of accidental skin injection, seek immediate “Surgical Treatment”.</p> <p>Failure to follow this warning can result in amputation or serious injury.</p>		
READ AND UNDERSTAND ALL LABELS AND INSTRUCTION MANUALS BEFORE USE			

Major Components

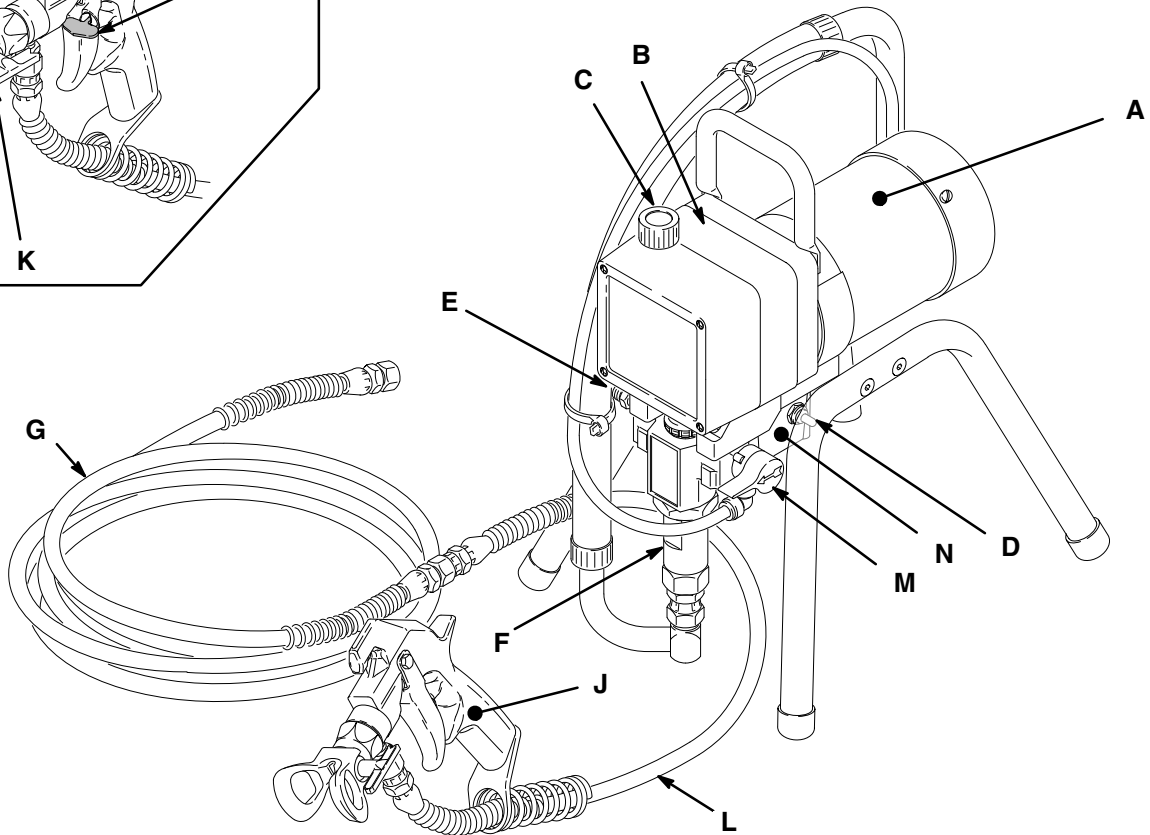
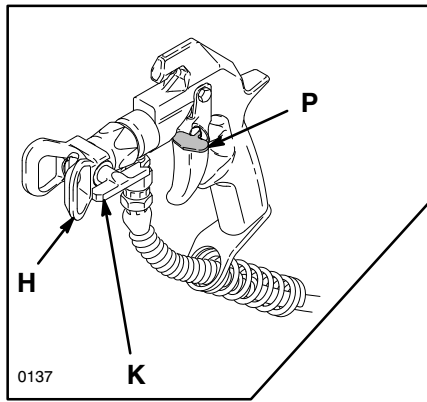

Fig. 1

04645

A	Motor	DC motor, 120 Vac, 15A, 1 phase
B	Drive Assembly	Transfers power from DC motor to the displacement pump
C	Pressure Adjusting Knob	Controls fluid outlet pressure
D	ON/OFF Switch	Power switch that controls 120 Vac power to sprayer
E	Fluid Outlet	Hose and spray gun is connected here
F	Displacement Pump	Pressurizes fluid to be sprayed through spray gun
G	50 ft (15 m) Main Hose	1/4 in. ID, grounded, nylon hose with spring guards on both ends
H	RAC IV Tip Guard	Reverse-A-Clean (RAC) tip guard reduces the risk of fluid injection injury
J	Flex Gun	High pressure spray gun with gun safety latch
K	RAC IV Switch Tip	RAC switch tip atomizes fluid and removes clogs from spray tip without removing tip from spray gun
L	3 ft (0.9 m) Hose	3/16 in. ID, grounded, nylon hose used between 50 ft hose and spray gun to allow more flexibility when spraying
M	Pressure Drain Valve	Relieves fluid pressure when open
N	Pressure Control	Controls motor to maintain fluid pressure. Works with pressure adjusting knob.
P	Spray Gun Safety Latch	Inhibits accidental triggering of spray gun

Setup

⚠ WARNING

If you supply your own hoses and spray gun, be sure the hoses are electrically conductive, that the gun has a tip guard, and that each part is rated for at least *2750 psi (195 bar) Working Pressure*. This is to reduce the risk of serious injury caused by static sparking, fluid injection or over-pressurization and rupture of the hose or gun.

⚠ CAUTION

To avoid damaging the pressure control, which may result in poor equipment performance and component damage, follow these precautions:

1. Always use a nylon spray hose at least 50 ft. (15 m) long.
2. Never use a wire braid hose as it is too rigid to act as a pulsation dampener.
3. Never install any shutoff device between the filter and the hose. See Fig. 2.

2. **Fill the wet-cup (102).** Pry off the wet-cup seal. Fill the cup 1/3 full with Graco Throat Seal Liquid (TSL), supplied. Install the wet-cup seal.
3. **Plug in the sprayer.** Be sure the ON/OFF switch (52) is OFF. Plug the cord into a grounded outlet at least 20 feet away from the spray area.

⚠ WARNING



FIRE AND EXPLOSION HAZARD

Proper electrical grounding is essential to reduce the risk of fire or explosion which can result in serious injury and property damage. Also read **FIRE OR EXPLOSION HAZARD** on page 2.

4. **Flush the pump** to remove the lightweight oil which was left in to protect pump parts after factory testing. See page 13.
5. **Prepare the paint** according to the manufacturers's recommendations. Remove any paint skin. Strain the paint through a fine nylon mesh bag (available at most paint dealers) to remove particles that could clog the spray tip. This is an important step toward trouble-free paint spraying.

1. **Connect the hose (74) and gun (67) and screw it onto the outlet nipple (28).** Don't use thread sealant, and don't install the spray tip yet!

- 1 1/4 npsm(m) fluid outlet
- 2 Do not install any shutoff device here
- 3 Rotate clockwise to increase pressure
- 4 Shown in closed or spray position
- 5 Fill 1/3 full with TSL

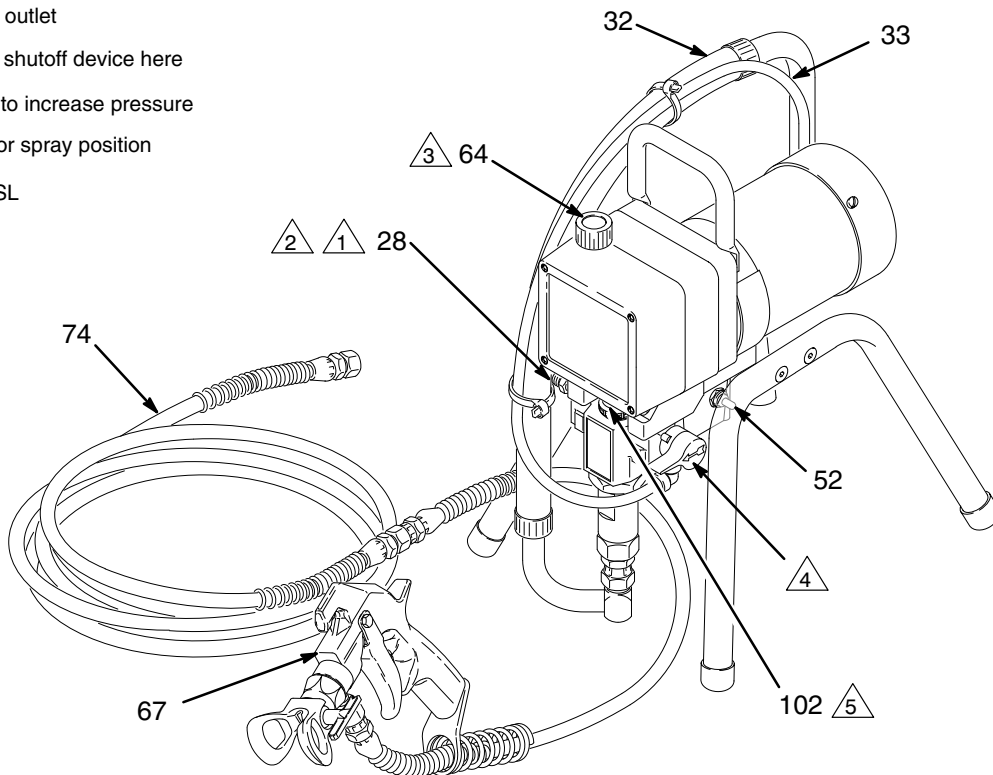

Fig. 2

04645

Operation



How to use the gun trigger safety

When engaged, the gun safety latch prevents the gun from accidental triggering. See Fig. 3.

⚠ WARNING



INJECTION HAZARD
If the gun still sprays when the gun trigger safety is locked, repair the gun. See manual 308–235, supplied.

-  Gun safety latch shown engaged
-  Gun safety latch shown disengaged

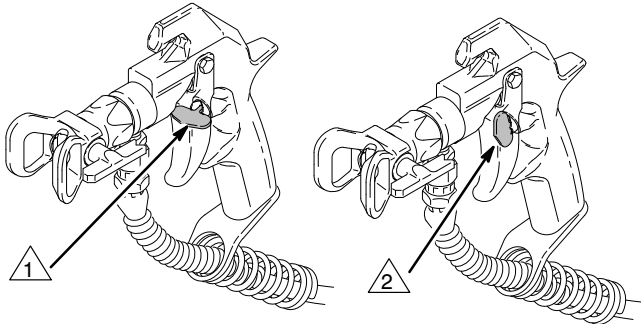



Fig. 3 0137

How to use the pressure drain valve.

Use the pressure drain valve to relieve fluid pressure from the pump and to help prime the pump. If the valve senses an over pressure condition, it opens automatically to relieve fluid pressure. If this happens, stop spraying immediately, shut off and unplug the sprayer. Determine the cause of the problem and correct it before operating the sprayer again. Refer also to the **Troubleshooting**, page 14. See Fig. 4.

-  Open or drain, position
-  Closed, or spray position

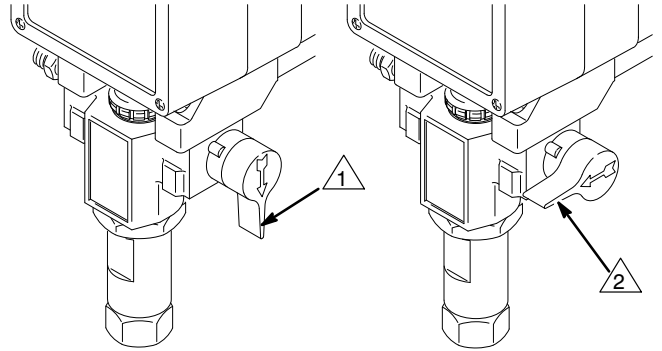

Fig. 4 04646

How to use the pressure control.

The pressure control controls the motor operation so the sprayer maintains constant fluid pressure at the pump outlet. Turn the pressure control knob fully counterclockwise to obtain the minimum setting. Turn the knob clockwise to increase pressure. See Fig. 5.

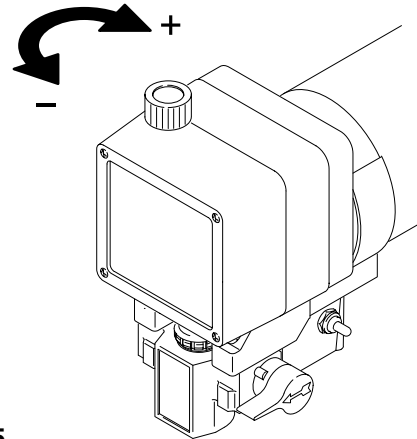



Fig. 5 01022A

Operation

How to use the RAC IV tip guard.

! WARNING	
	INJECTION HAZARD
	To reduce the risk of serious injury, whenever you are instructed to relieve pressure, follow the Pressure Relief Procedure on page 9.

The tip guard alerts you to the risk and helps prevent placing any part of the body close to the spray tip. The tip guard also adjusts the vertical or horizontal spray pattern. See Fig. 8. The tip guard holds a reversing spray tip. The tip is in the spraying position when the tip handle points forward. See Fig. 6.

Clean the front of the tip frequently during the day's operation. First, follow the **Pressure Relief Procedure** on page 9.

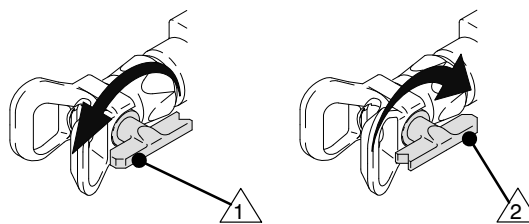



-  Tip handle shown in spraying position.
-  Turn handle 180°, trigger gun to clear clog

Fig. 6

04647

How to remove a tip clog.

1. Release the gun trigger. Lock the safety latch. Rotate the RAC IV tip handle 180°. See Fig. 6.
2. Unlock the safety latch. Trigger the gun into a pail or onto the ground to remove the clog.
3. Lock the safety latch. Rotate the tip handle to the spraying position.
4. If the tip is still clogged, lock the safety latch, shut off and unplug the sprayer, and open the pressure drain valve to relieve pressure. Clean the spray tip as shown in manual 307–848, supplied.

Startup

⚠ WARNING



INJECTION HAZARD

The system pressure must be manually relieved to prevent the system from starting or spraying accidentally. Fluid under high pressure can be injected through the skin and cause serious injury. To reduce the risk of an injury from injection, splashing fluid, or moving parts, follow the **Pressure Relief Procedure** whenever you:

- are instructed to relieve the pressure,
- stop spraying,
- check or service any of the system equipment,
- or install or clean the spray tip.

Pressure Relief Procedure

1. Engage the gun safety latch.
2. Turn the ON/OFF switch to OFF.
3. Unplug the power supply cord.
4. Disengage the gun safety latch. Hold a metal part of the gun firmly to a grounded metal pail. Trigger the gun to relieve pressure.
5. Engage the gun safety latch.
6. Open the pressure drain valve. Leave the pressure drain valve open until you are ready to spray again.

If you suspect that the spray tip or hose is completely clogged, or that pressure has not been fully relieved after following the steps above, VERY SLOWLY loosen the tip guard retaining nut or hose end coupling to relieve pressure gradually, then loosen completely. Now clear the tip or hose obstruction.

Startup Procedure

Use this procedure each time you start the sprayer to help ensure the sprayer is ready to operate and that you start it safely.

NOTE: If this is a first-time startup, flush the sprayer. See page 13.

NOTE: Refer to Fig. 9 and the other figures referenced in the text as you start the sprayer.

1. **Open the pressure drain valve (42).** See Fig. 7.
2. **Don't install the spray tip until the pump is primed!**

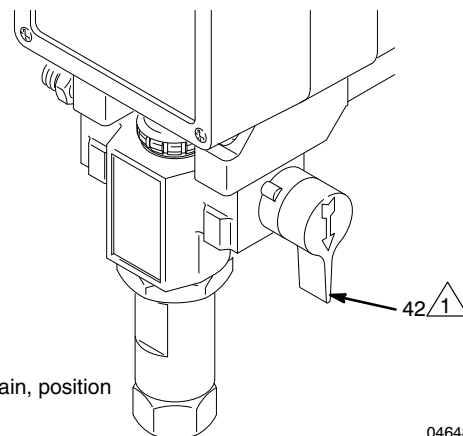

Fig. 7 04648

3. **Turn the pressure knob (64) to the minimum setting.**
4. **Disengage the gun trigger safety.** See Fig. 3, page 7.

⚠ CAUTION

Do not run the sprayer dry for more than 30 seconds to avoid damaging the pump packings.

5. **To prime the pump,** turn the sprayer switch (52) on. Slowly increase the pressure until the sprayer starts. When fluid comes from the pressure drain valve, close the valve.

Startup

WARNING



FIRE AND EXPLOSION HAZARD

To reduce the risk of static sparking and splashing when priming or flushing the system, hold a metal part of the gun firmly to the side of a grounded metal pail before triggering the gun.

6. **To prime the hose**, lower the pressure to reduce splashing. Hold a metal part of the gun firmly against and aimed into a grounded metal pail. See the preceding WARNING. Hold the gun trigger open and slowly increase the pressure until the pump starts. Keep the gun triggered until all air is forced out of the system and the fluid flows freely from the gun. Release the trigger and engage the gun safety latch.
7. **Check all fluid connections for leaks.** Relieve pressure before tightening the connections.
8. Engage the gun safety latch.
9. **Install the spray tip and tip guard.** Install the spray tip. If you are using the RAC IV tip guard, refer to manual 307–848 for installation instructions.
10. **Adjust the spray pattern**
 - a. Increase the pressure until spray from the gun is completely atomized. To avoid excessive overspray and fogging, and to extend tip and sprayer life, always use the lowest pressure needed to get the desired results.

- b. If more coverage is needed, use a larger tip rather than increasing the pressure.
- c. Adjust the direction of the spray pattern. See Fig. 8. Engage the gun safety latch. Loosen the retaining nut (A). Position the tip guard for a horizontal or vertical pattern. Hold the tip guard in place and tighten the retaining nut.

NOTE: Spray patterns will change as tips wear. Change the spray tip if adjusting the pressure will not improve the spray pattern.

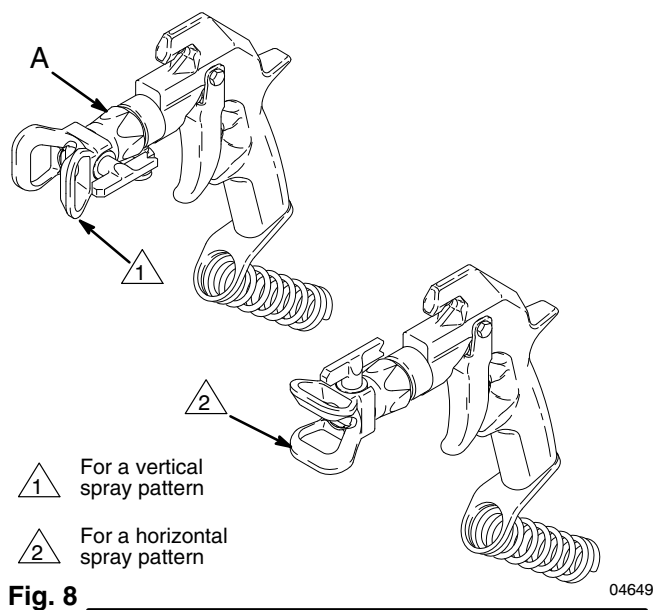

Startup

- △ 1 1/4 npsm(m) fluid outlet
- △ 2 Do not install any shutoff device here
- △ 3 Rotate clockwise to increase pressure
- △ 4 Shown in closed or spray position
- △ 5 Fill 1/3 full with TSL

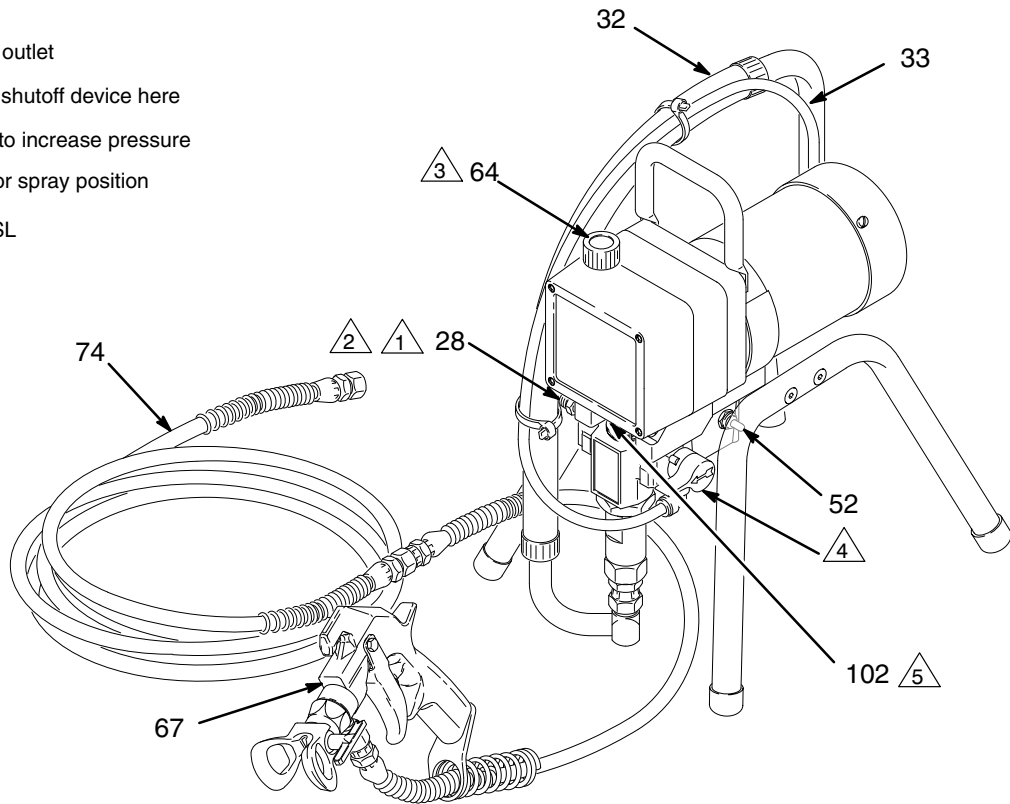

Fig. 9

04645

Shutdown and Care

⚠ WARNING



INJECTION HAZARD

To reduce the risk of serious injury, whenever you are instructed to relieve pressure, follow the **Pressure Relief Procedure** on page 9.

⚠ WARNING



INJECTION HAZARD

See the warning section **INJECTION HAZARD** on page 3 for information on the hazard of using damaged hoses.

Shutdown and Care

1. **Check the packing nut/wet-cup daily (102).** Relieve pressure first. Keep the wet-cup 1/3 full of TSL at all times to help prevent fluid buildup on the piston rod and premature wear of packings.
2. **Tighten the packing nut/wet-cup (102) just enough to stop leakage.** Over-tightening causes binding and excessive packing wear. Use a round punch or brass rod and a light hammer to adjust the nut. See Fig. 10.
3. **Periodically clean paint residue from the pressure transducer (29) vent hole area.** See Fig. 11. Replace the transducer when leakage is excessive. See page 31.
4. **Lubricate the bearing housing** after every 100 hours of operation. Remove the front cover. Fill the bearing housing cavity (A) with SAE 10 non-detergent oil. See Fig. 11.
5. **Flush the sprayer at the end of each work day** and fill it with mineral spirits to help prevent pump corrosion and freezing. See page 13.

⚠ CAUTION

To prevent pump corrosion, and to reduce the chance of fluid freezing in the pump in cold weather, never leave water or any type of paint in the sprayer when it is not in use. Freezing can seriously damage the sprayer or result in a loss of pressure or stalling.

6. **For very short shutoff periods,** leave the suction tube in the paint, relieve pressure, and clean the spray tip.
7. **Coil the hose and hang it on a hose rack** when storing it, even for overnight, to help protect the hose from kinking, abrasion, coupling damage, etc.

- 1 Turn packing nut clockwise to tighten

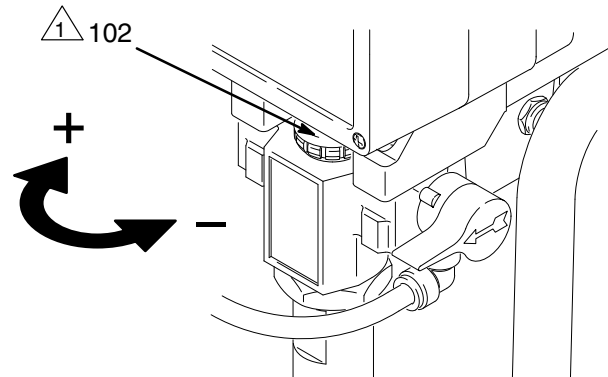

Fig. 10

04650

- 1 Vent hole

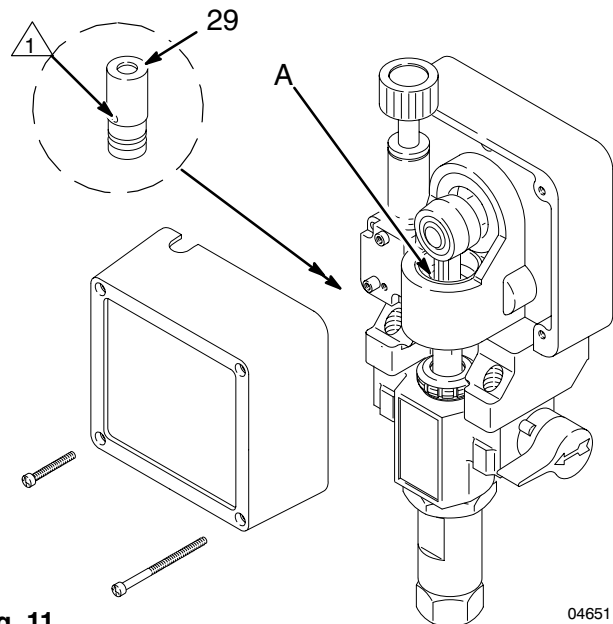

Fig. 11

04651

Flushing

When to Flush

1. **Before using a new sprayer:** flush out the oil which was left in to protect pump parts.

Before using water-base paint: flush with mineral spirits followed by soapy water, and then a clean water flush.

Before using oil-base paint: flush with mineral spirits only.
2. **Changing colors:** flush with a compatible solvent such as mineral spirits or water.
3. **Changing from water-base to oil-base paint:** flush with warm, soapy water, and then mineral spirits.
4. **Changing from oil-base to water-base paint:** flush with mineral spirits, then warm, soapy water, and then a clean water flush.
5. **Storage after using water-base paint:** flush with water and then mineral spirits. Leave the system filled with mineral spirits. Relieve pressure. Leave the drain valve open.

Storage after using oil-base paint: flush with mineral spirits. Relieve pressure. Leave the drain valve open.

CAUTION

Never allow water to freeze in the pressure control. Doing so prevents the sprayer from being started and may cause serious damage. Push the water out with mineral spirits.

6. **Startup after storage.** Before using water-base paint, flush out the mineral spirits with soapy water and then clean water. When using oil-base paint, flush out the mineral spirits with the paint.

How to Flush

1. Follow the **Pressure Relief Procedure** on page 9.
2. Remove the spray tip and clean it separately.

3. Pour one-half gallon (2 liters) of compatible solvent into a grounded metal flushing pail. Put the suction hose in the pail.
4. Open the pressure drain valve. See Fig. 4, page 7.
5. **To save the paint still in the pump and hose,** follow Step 6, except put the drain tube in the paint pail. When solvent appears, close the drain valve. Put the drain tube in the flushing pail. Trigger the gun into the paint pail. When solvent appears, release the trigger. Continue with Step 6.

WARNING



FIRE AND EXPLOSION HAZARD

To reduce static sparking and splashing, always remove the spray tip from the gun, and hold a metal part of the gun firmly to the side of a grounded metal pail when flushing.

6. Lower the pressure setting. Turn on the sprayer. Maintaining metal-to-metal contact, trigger the gun into the flushing pail. Slowly increase the sprayer pressure until the pump starts. Keep the gun triggered until the solvent flows freely from the gun. Circulate the solvent to thoroughly clean the sprayer. Release the gun trigger. Engage the gun trigger safety.
7. Open the drain valve and circulate the solvent through the drain tube to thoroughly clean it. Close the drain valve.
8. Remove the suction hose from the pail. Disengage the gun trigger safety. Trigger the gun and run the pump a few seconds to push air into the hose. Do not run the pump dry for more than 30 seconds to avoid damaging the pump packings! Relieve pressure.
9. Remove and clean the inlet strainer. Wipe paint off the suction hose and drain tube.
10. Refer to **When To Flush**, Step 1 again. Relieve pressure.
11. Leave the drain valve open until you use the sprayer again.

Troubleshooting

WARNING

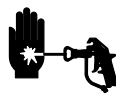

INJECTION HAZARD

To reduce the risk of serious injury, whenever you are instructed to relieve pressure, follow the **Pressure Relief Procedure** on page 9.

Basic Problem Solving

Check everything in the troubleshooting table before disassembling the sprayer.

TYPE OF PROBLEM	WHAT TO CHECK <i>If check is OK, go to next check</i>	WHAT TO DO <i>When check is not OK, refer to this column</i>
Fluid pressure	1. Check pressure control knob setting. The pump won't develop much pressure if it is at minimum setting (fully counterclockwise).	1. Slowly increase pressure setting to see if motor starts.
	2. Check for a clogged spray tip or fluid filter, if used. See page 8.	2. If tip is still clogged, relieve pressure; refer to separate gun or tip instruction manual for tip cleaning. Clean the filter, if used.
Mechanical	1. Check for frozen or hardened paint in pump (20). Using a screwdriver, carefully try to rotate fan at back of motor by hand. See page 18.	1. Thaw. Plug in sprayer and turn on. Slowly increase pressure setting to see if motor starts. If it doesn't, see NOTE, below.
	2. Check pump connecting rod pin (17). It must be completely pushed into connecting rod (15), and retaining spring (18) must be firmly in connecting rod groove. See Fig. 18, page 22.	2. Push pin into place and secure with spring retainer.
	3. Check for motor damage. Remove drive housing assembly (11). See page 28. Try to rotate motor fan by hand.	3. Replace motor (4) if fan won't turn. See page 26.
Electrical	1. Check electrical supply with volt meter. Meter should read 105–125 VAC.	1. Reset building circuit breaker; replace building fuse. Try another outlet.
	2. Check extension cord for visible damage. Use a volt meter or test lamp at extension cord outlet to check.	2. Replace extension cord.
	3. Check sprayer power supply cord (50) for visible damage such as broken insulation or wires.	3. Replace power supply cord. See page 27.
	4. Check motor brushes for the following: a. Loose terminal screws. b. Broken or misaligned brush springs. c. Brushes binding in holders. d. Broken leads. e. Worn brushes. NOTE: The brushes do not wear at same rate on both sides of motor. Check both brushes.	4. Refer to page 20. a. Tighten. b. Replace broken spring and/or align spring with brush c. Clean brush holders. Remove carbon with small cleaning brush. Align brush leads with slot in brush holder to assure free vertical brush movement. d. Replace brushes e. Replace brushes if less than 0.5 in. long.

NOTE: Thaw sprayer if water or water-based paint has frozen in it, due to exposure to low temperatures, by placing in a warm area. Do not try to start sprayer until completely thawed or damage to motor and/or start board may occur. If paint hardened (dried) in sprayer, the pump packings (page 22) and/or pressure transducer (page 31) must be replaced.

Basic Problem Solving

TYPE OF PROBLEM	WHAT TO CHECK <i>If check is OK, go to next check</i>	WHAT TO DO <i>When check is not OK, refer to this column</i>
Electrical <i>(continued)</i>	5. Check motor armature commutator for burn spots, gouges and extreme roughness. Remove motor cover and brush inspection plates to check. See page 20.	5. Remove motor and have motor shop resurface commutator if possible. See page 26.
	6. Check motor armature for shorts using armature tester (growler) or perform motor test. See page 18.	6. Replace motor. See page 26.
	7. Check leads from pressure control and motor to motor start board (47) to be sure they are securely fastened and properly mated.	7. Replace loose terminals; crimp to leads. Be sure male terminal blades are straight and firmly connected to mating part.
	8. Check motor start board (47) by substituting with a good board. See page 27. CAUTION: Do not perform this check until motor armature is determined to be good. A bad motor armature can burn out a good board.	8. Replace board. See page 27.
	9. Check power supply cord (50). Disconnect black and white power cord terminals; connect volt meter to these leads. Plug in sprayer. Meter should read 105–125VAC. Unplug sprayer.	9. Replace power supply cord. See page 27.
	10. Check ON/OFF switch (52). Disconnect the motor start board (47) and switch and connect volt meter between exposed terminal on switch and power cord's white wire. Plug in sprayer and turn ON . Meter should read 105–125VAC Turn off and unplug sprayer.	10. Replace ON/OFF switch. See page 27.
	11. Check motor thermal cutout switch. Connect ohmmeter between motor's red leads. Meter should read 1 ohm maximum.	11. Allow motor to cool. Correct cause of overheating. If switch remains open after motor cools, replace motor.
	12. Remove pressure control (64) and check microswitch operation with ohmmeter: (1) With pressure knob at lowest setting and stem pushed into control, readings should be: white & black = 1 ohm max. white & red = open. (2) With pressure knob at highest setting, readings should be: white & black = open; white & red = 1 ohm max.	12. Replace pressure control. See page 30.
13. Check pressure transducer (29) for hardened paint or damaged or worn components. See page 31.	13. Replace transducer. See page 31. Thorough system flushing will help extend life of transducer.	

Intermediate Problem Solving

TYPE OF PROBLEM	WHAT TO CHECK <i>If check is OK, go to next check</i>	WHAT TO DO <i>When check is not OK refer to this column</i>
Low output	1. Check for worn spray tip.	1. Follow Pressure Relief Procedure then replace tip. See your separate gun or tip manual.
	2. Be sure pump does not continue to stroke when gun trigger is released. Plug in and turn on sprayer. Prime with paint. Trigger gun momentarily, then release and lock safety latch. Relieve pressure, turn off and unplug sprayer.	2. Service pump. See page 22.

Intermediate Problem Solving

TYPE OF PROBLEM	WHAT TO CHECK <i>If check is OK, go to next check</i>	WHAT TO DO <i>When check is not OK, refer to this column</i>
Low output (<i>continued</i>)	3. Release gun trigger. Observe resting position of pump rod (107).	3. If pump consistently comes to rest with rod (107) fully extended, the piston packings and/or piston valve may be worn. Service the pump. See page 22.
	4. Check electrical supply with volt meter. Meter should read 105–125VAC.	4. Reset building circuit breaker; replace building fuse. Repair electrical outlet or try another outlet.
	5. Check extension cord size and length; must be at least 12 gauge wire and less than 150 ft (45 m) long.	5. Replace with a correct, grounded extension cord.
	6. Check motor brushes. See Electrical – What To Check, item 4, on page 14.	6. See page 20.
	7. Check motor start board (47) by substituting with a good board. CAUTION: Do not perform this check until motor armature is determined to be good. A bad motor armature can burn out a good board.	7. Replace board. See page 27.
	8. Check motor armature for shorts by using an armature tester (growler) or perform motor test. See page 18.	8. Replace motor. See page 26.
Drain valve leaks	1. Check drain valve for correct torque and/or worn parts. Check for debris trapped on seat.	9. Tighten to 185 in–lb (21 N.m). Clean valve and replace with new gasket (42a) and sealant (42d). See page 32.
Transducer leaks	1. Slight leakage from transducer is normal.	1. Periodically remove residue from its cylinder port. See page 31.
No output: motor runs and pump strokes	1. Check paint supply.	1. Refill and reprime pump.
	2. Check for clogged intake strainer.	2. Remove and clean, then reinstall.
	3. Check for loose suction tube or fittings. See page 34.	3. Tighten; use thread sealant on npt threads of adapter (38).
	4. Check to see if intake valve ball and piston ball are seating properly. See page 22.	4. Remove intake valve and clean. Check ball and seat for nicks; replace as needed. See page 22. Strain paint before using to remove particles that could clog pump.
	5. Check for leaking around throat packing nut which may indicate worn or damaged packings. See page 22.	5. Replace packings. See page 22. Also check piston valve seat for hardened paint or nicks and replace if necessary. Tighten packing nut/wet-cup.
	6. Release gun trigger. Observe resting position of pump rod (107).	6. If pump consistently comes to rest with rod (107) fully extended, the piston packings and/or piston valve may be worn. Service the pump. See page 22.
No output: motor runs but pump does not stroke	1. Check displacement pump connecting rod pin (17). See Fig. 18, page 22.	1. Replace pin if missing. Be sure retainer spring (18) is fully in groove all around connecting rod.
	7. Check connecting rod assembly (15) for damage. See page 28.	7. Replace connecting rod assembly. See page 28.
	8. Be sure crank in drive housing rotates; plug in sprayer and turn on briefly to check. Turn off and unplug sprayer. See page 28.	8. Check drive housing assembly for damage and replace if necessary. See page 28.

Intermediate Problem Solving

TYPE OF PROBLEM	WHAT TO CHECK <i>If check is OK, go to next check</i>	WHAT TO DO <i>When check is not OK, refer to this column</i>
Spray Pattern Variations	1. Spray tip worn beyond sprayer pressure capability.	1. Replace spray tip. NOTE: A smaller size tip will provide longer life.
	2. Check transducer (29) for wear or damage.	2. Replace transducer. See page 31.
	3. Check pressure control (64) for smooth operation.	3. Replace pressure control. See page 30.
	4. Check Low output section, page 16.	
Motor Is Hot and Runs Intermittently	1. Determine if sprayer was operated at high pressure with small tips, which causes excessive heat build up.	1. Decrease pressure setting or increase tip size.
	2. Be sure ambient temperature where sprayer is located is no more than 90°F (32°C) and sprayer is not located in direct sun.	2. Move sprayer to shaded, cooler area if possible.
	3. Check motor.	3. Replace motor. See page 26.
Building Circuit Breaker Opens As Soon As Sprayer Switch Is Turned On.	1. Check all electrical wiring for damaged insulation, and all terminals for loose fit or damage. Also check wires between pressure control and motor. See page 26.	1. Repair or replace any damaged wiring or terminals. Securely reconnect all wires.
	2. Check for missing motor brush inspection plate gasket (see page 18), bent terminal forks or other metal to metal contact points which could cause a short.	2. Correct faulty conditions.
	3. Check motor armature for shorts. Use an armature tester (growler) or perform motor test. See page 18. Inspect windings for burns.	3. Replace motor. See page 26.
	4. Check motor start board (47) by substituting with a good board. CAUTION: Do not perform this check until motor armature is determined to be good. A bad motor armature can burn out a good board.	4. Replace board. See page 27.
Circuit breaker opens after sprayer operates for 5 to 10 minutes.	1. Check 'Basic Problems – Electrical' on page 14.	
Building circuit breaker opens as soon as sprayer is plugged into outlet and sprayer is NOT turned on.	1. Check ON/OFF switch (52). <i>Be sure sprayer is unplugged!</i> Disconnect wires from switch. Check switch with ohmmeter. The reading should be infinity with ON/OFF switch OFF, and zero with switch ON. CAUTION: A short in motor circuit can damage switch and or motor start board (47).	1. Replace ON/OFF switch. See page 27.
	2. Check electrical supply with volt meter. Meter should read 105–125 VAC.	2. If voltage is too high, do not operate sprayer until corrected.
Unit will not run on generator but does run on AC power	Check the generator's peak voltage. This sprayer will not run if the peak voltage is above 190V.	Use AC power or a different generator

Motor Test

⚠ WARNING



INJECTION HAZARD

To reduce the risk of serious injury, whenever you are instructed to relieve pressure, follow the **Pressure Relief Procedure** on page 9.

For checking armature, motor winding and brush electrical continuity.

Setup

Remove the drive housing. See page 28. This is to ensure that any resistance you notice in the armature test is due to the motor and not to worn gears in the drive housing.

Remove the motor brush inspection covers (A). See Fig. 12.

Remove the junction box screws (56). Lower the junction box. Disconnect the two leads (C) from the motor to the board (47). See Fig. 13.

Armature Short Circuit Test

Remove the fan cover (B). See Fig. 12.

Spin the motor fan by hand. If there are no shorts, the motor will coast two or three revolutions before coming to a complete stop. If the motor does not spin freely, the armature is shorted and the motor must be replaced. See page 26.

Armature, Brushes, and Motor Wiring Open Circuit Test (Continuity)

Connect the two black motor leads together with a test lead. Turn the motor fan by hand at about two revolutions per second.

When turning the fan on a DC motor, normally you sense an even, pulsing resistance. If there is irregular turning resistance, or no turning resistance, check and repair the following as needed: broken brush springs, brush leads, motor leads; loose brush terminal screws or motor lead terminals; worn brushes. See page 20.

If there is still uneven or no turning resistance, replace the motor. See page 26.

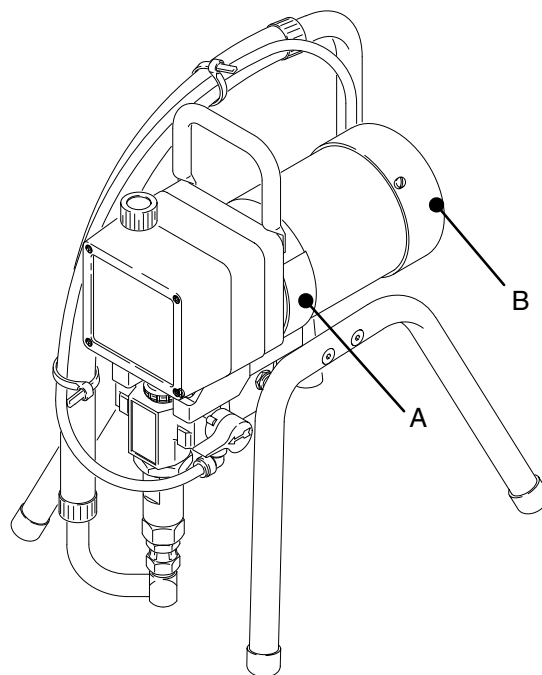

Fig. 12

04652

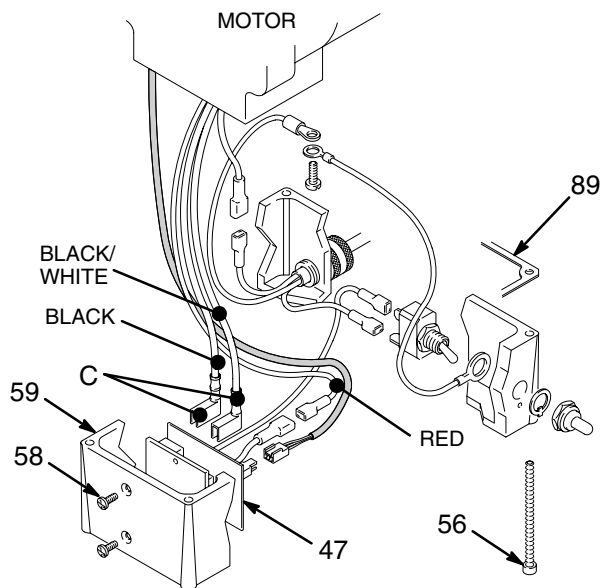

Fig. 13

04720

General Repair Information

WARNING



INJECTION HAZARD

To reduce the risk of serious injury, whenever you are instructed to relieve pressure, follow the **Pressure Relief**

Procedure on page 9.

Tool List

These are the tools required to service all parts of the sprayer.

3/16" Allen® wrench: *gear housing, legs, handle*

3/8" Allen® wrench: *pump manifold*

#1 Phillips® screwdriver: *junction box, pressure control, front cover*

3/8" socket wrench: *motor mount*

5/8" socket wrench: *drain valve, outlet fittings, on/off switch boot, piston*

13/16" socket wrench: *drain valve*

1-1/4" socket wrench: *pump inlet valve*

1/2" open end wrench: *pump rod*

11/16" open end wrench: *piston jam nut*

15/16" open end wrench: *flats of inlet tube*

1-3/4" open end wrench: *pump jam nut*

5/64" drive pin: *drain valve pin*

3" needle nose pliers: *wiring, on/off switch*

Hammer & punch: *packing nut*

Torque wrenches: *various fasteners*

WARNING



MOVING PARTS HAZARD

To reduce the risk of serious injury, including electric shock, **DO NOT** touch any moving parts or electrical parts with your fingers or a tool while inspecting the repair.

Shut off the sprayer and unplug it as soon as you complete the inspection.

Reinstall all covers, gaskets, screws and washers before operating the sprayer.

WARNING



HOT SURFACE HAZARD

During operation, the motor and drive housing become very hot and could burn your skin if touched. Flammable materials spilled on the hot, bare motor could cause a fire or explosion.

CAUTION

To reduce the risk of a pressure control malfunction, be sure to properly mate connectors, and never pull on a wire to disconnect it. Pulling on a wire could loosen the connector from the wire.

1. **When disconnecting wires** in the junction box assembly, use needle nose pliers to separate mating connectors.
2. **When reconnecting the wires**, be sure the flat blade of the insulated male connector is centered in the wrap-around blade of the female connector.

CAUTION

Improper wire routing can result in poor sprayer performance or damage to the pressure control.

3. **Route wires carefully** through the drive housing and motor. Avoid pinching the wires between the junction box and the motor or pressure control.
4. **Keep all screws, nuts, washers, gaskets, and electrical fittings** removed during repair procedures. These parts are not normally provided with replacement assemblies.
5. **Test your repair before regular operation** to be sure the problem is corrected.
6. **If the sprayer does not operate properly**, verify that everything was done correctly. Also refer to the Troubleshooting Guide, pages 14–18, to help identify other possible problems and solutions.

Motor Brushes

NOTE: Replace brushes when worn to about 0.5 in. (12.5 mm). Always check both brushes. Brush Repair Kit 236-967, which includes spring clip 112-766, is available for motors manufactured by Pacific Scientific.

NOTE: Replacement brushes may last only half as long as the original ones. To maximize brush life, break in new brushes by operating the sprayer for at least one hour with no load (remove the pump connecting rod pin).

⚠ WARNING

INJECTION HAZARD

To reduce the risk of serious injury, whenever you are instructed to relieve pressure, follow the **Pressure Relief Procedure** on page 9.

1. Remove both inspection covers (A) and their gaskets. See Fig 14.

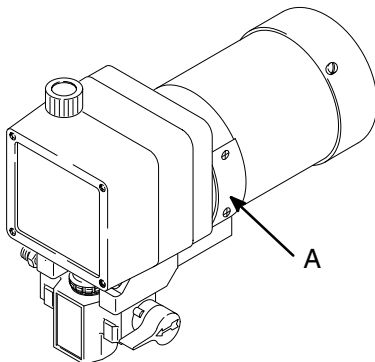

Fig. 14 04653

2. Push in the spring clip (F) and release its hook (G) from the brush holder (B). Pull out the spring clip. See Fig 15.
3. Slide off the brush lead terminal (E) off the blade connector. Remove the old brush (C). See Fig 15.

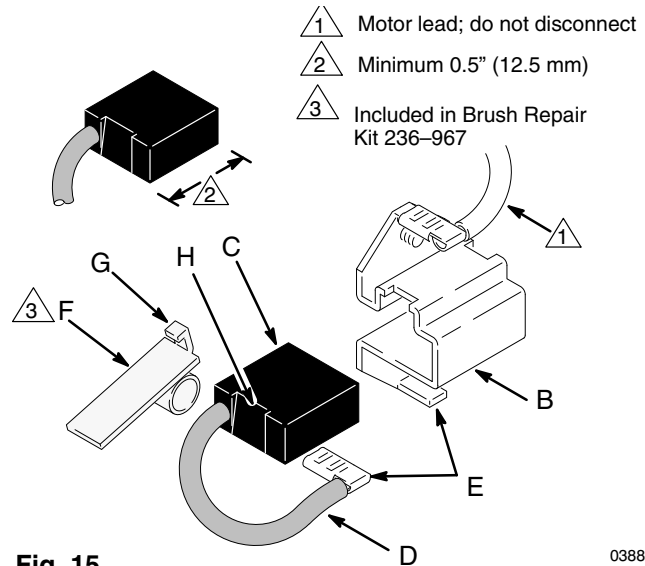

Fig. 15 03881

4. Inspect the commutator for excessive pitting, burning or gouging. A black color on the commutator is normal. Have the commutator resurfaced by a qualified motor repair shop if the brushes seem to wear too fast or arc excessively. See Step 9.d., also.

5. Repeat for the other side.

NOTE: The motor brushes on the other side are upside down.

6. Place a new brush (C) in the holder (B) so the ramp (H) faces the spring (G). See Fig. 16.

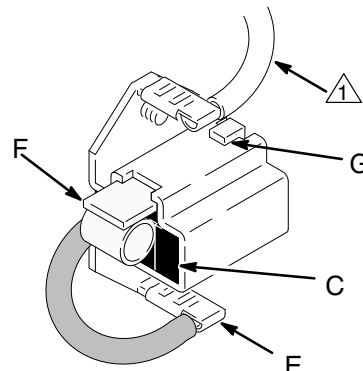



Fig. 16 03881

7. Holding the spring clip (F) at a slight angle, slide the spring clip into the brush holder and hook it over the end of the holder. See Fig. 16. Pull on the spring clip to be sure it stays in place. Connect the brush lead to the blade connector (E).
8. Repeat for the other side.

Motor Brushes

9. Test the brushes.

- a. Remove the pump connecting rod pin (17). See Fig. 18, page 22.
- b. With the sprayer OFF, turn the pressure control knob fully counterclockwise to minimum pressure. Plug in the sprayer.
- c. Turn the sprayer ON. Slowly increase the pressure until the motor is at full speed.
- d. Inspect the brush and commutator contact area for excessive arcing. Arcs should not trail or circle around the commutator surface.

! WARNING	
	MOVING PARTS HAZARD Do not touch the brushes, leads, springs or brush holders while the sprayer is plugged in to reduce the risk of electric shock and serious injury.

10. Install the brush inspection covers and gaskets.

11. **Break in the brushes.** Operate the sprayer for at least one hour with no load. Install the pump connecting rod pin. See Fig. 18, page 22.

Displacement Pump Repair

WARNING

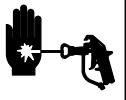

INJECTION HAZARD

To reduce the risk of serious injury, whenever you are instructed to relieve pressure, follow the **Pressure Relief Procedure** on page 9.

NOTE: Packing Repair Kit 235-703 is available. Reference numbers of parts included in the kit are marked with an asterisk, i.e., (121*). For the best results, use all the new parts in the kit, even if the old ones still look good.

NOTE: To minimize down time, and for the best sprayer performance, check the motor brushes (see page 20) and clean the transducer (see page 31) whenever you re-pack the pump. Replace these parts as needed.

Removing the pump (See Fig. 17.)

1. Flush the pump, if possible. Relieve pressure. Stop the pump with the piston rod (107) in its lowest position, if possible. To lower the piston rod manually, rotate the motor fan blades.
2. Loosen the swivel nut on adapter (38) and remove suction hose (32). While pushing in on the collar of elbow (36), pull out and remove drain tube (33).

NOTE: If repairing only the intake valve assembly, go to **Intake valve repair**, page 23.

3. Use a screwdriver to push the retaining spring (18) up and push out the pin (17).
4. Loosen the screws (21). Remove the pump (20).

Installing the pump (See Fig. 18 and 19.)

1. Mount the pump on the drive housing. Tap it into the alignment pins with a soft hammer. Tighten the screws (21) to 50 ft-lb (68 N.m).

2. Align the hole in the rod (107) with the connecting rod assembly (15). Use a screwdriver to push the retaining spring (18) up and push in the pin (17). Push the retaining spring (18) into place around the connecting rod.
3. Reconnect the suction and drain hoses (32,33). Install the front cover (13).
4. Tighten the packing nut (102) just enough to stop leakage, but no tighter. Fill the packing nut/wet-cup 1/3 full with Graco TSL. Push the plug (123) into the wet-cup.

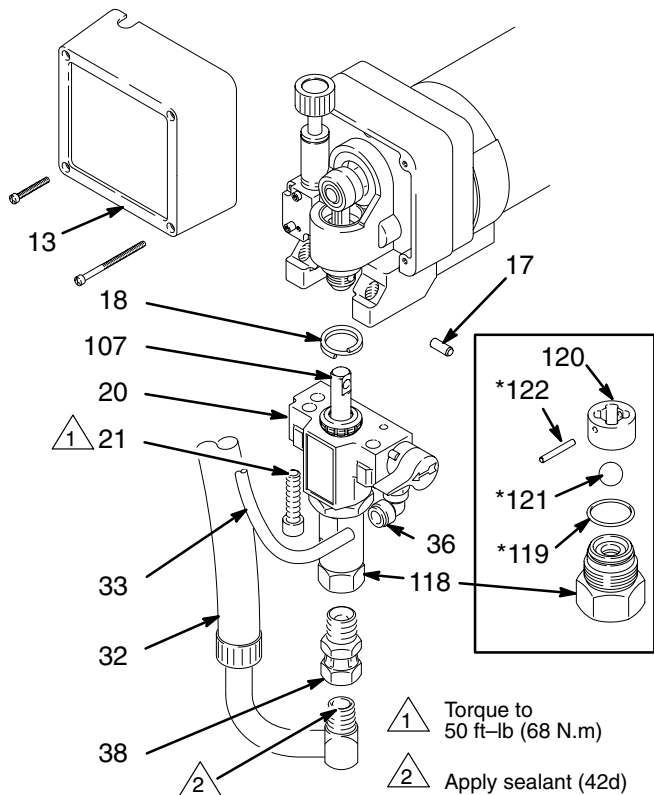

Fig. 17

04654



WARNING

MOVING PARTS HAZARD

Be sure the retaining spring (18) is firmly in the groove all the way around, to prevent the pin (17) from working loose due to vibration. See Fig. 18.

If the pin works loose, it or other parts could break off due to the force of the pump action. These parts could be projected into the air and result in serious injury or property damage, including the pump connecting rod or drive housing.

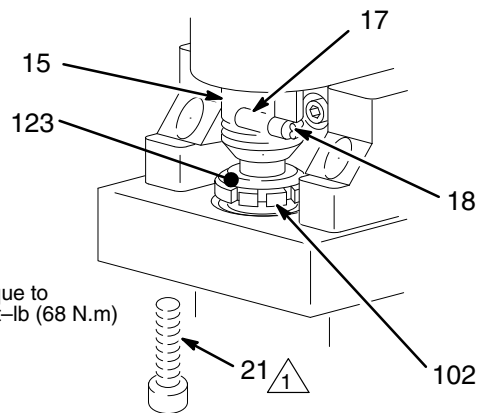

Fig. 18

04655

Displacement Pump Repair

Intake valve repair (See Fig. 17)

1. Remove the suction hose. See Step 2, **Removing the pump**.
2. Unscrew the intake valve (118). Remove the o-ring (119*), ball guide (120), stop pin (122*) and ball (121*) from the valve.
3. Clean and inspect the parts for wear or damage. Replace parts as needed. Use a new o-ring (119*). If no further service is needed, reassemble the pump.

Disassembling the pump (See Fig. 19.)

1. Remove the intake valve (118). See page
2. Loosen the packing nut (102) and plug (123).
3. Use a plastic mallet to tap the piston rod (107) down, and then pull the rod out through the bottom of the cylinder.
4. Remove the packing nut (102) and throat packings.
5. Loosen the jam nut (117). Remove the cylinder (115) and the o-ring (116*).
6. Clamp the flats of the piston rod in a smooth jaw vise. Use an open-end wrench to loosen the nut (110) and then unscrew the piston valve (108).
7. Remove all parts from the piston valve (108).

Reassembling the pump

NOTE: Alternate plastic and leather packings. See Fig. 19. The lips of the throat V-packings face down. The lips of the piston V-packings face up. Incorrect installation damages the packings and causes pump leakage.

NOTE: Soak the leather packings in oil before reassembling the pump.

1. Check the outside of the piston rod (107) and the inside of the cylinder (115) for wear. Replace worn parts to ensure a good seal with the new packings.
2. Stack these parts onto the piston valve (108) one at a time: the female gland (114*), alternately three plastic (112*) with two leather packings (113*), and the male gland (111*). See Fig. 19.

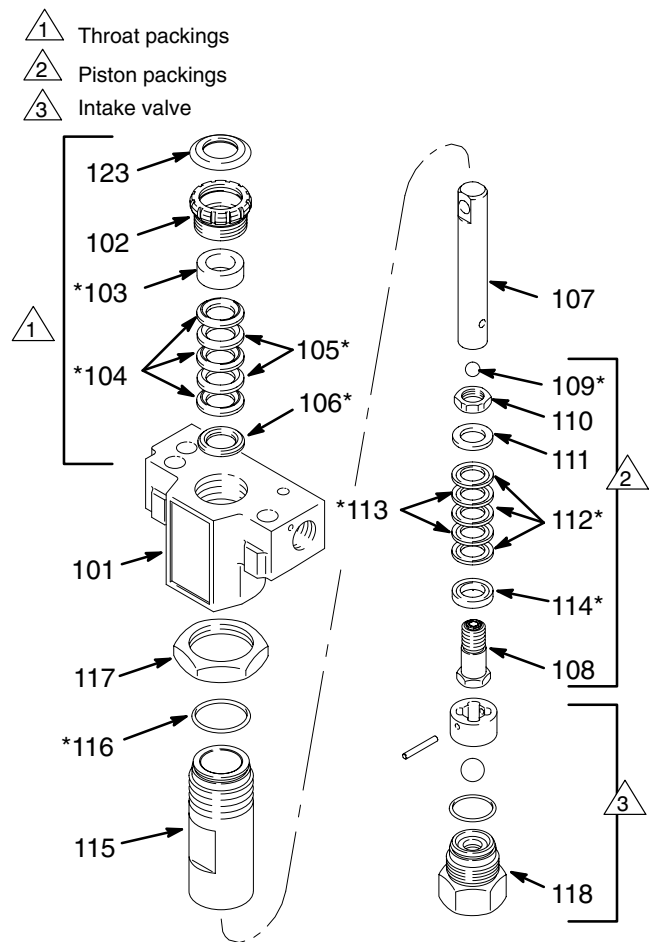

Fig. 19

01069A

Displacement Pump Repair

- Tighten the nut (110) onto the piston valve (108) to 2 in-lb (0.23 N.m). See Fig. 20.

NOTE: Note the alignment of the piston (108) to the nut (110). Maintain this alignment through Step 8.

- Clean all residue from the piston valve threads. Apply one drop of adhesive, supplied, to the threads.
- Place the ball (109*) on the piston valve (108). See Fig. 20.

- Torque to 2 in-lb (0.23 N.m)
- Apply one drop of sealant to these threads

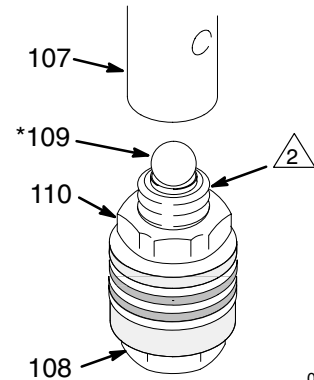

Fig. 20

01070

CAUTION

Step 6, tightening the piston valve into the rod, is critical. Follow the procedure carefully to avoid damaging the packings by overtightening.

- Hand tighten the valve into the piston rod just until the nut (110) contacts the rod. See Fig. 21.
- Place the flats of the rod (107) in a smooth jaw vise.
- CAREFULLY** tighten the nut (110) against the piston rod to 19 ft-lb (25 N.m). See Fig. 21.

- Torque nut against rod to 19 ft-lb (25 N.m)

- Do not allow nut (110) to move relative to piston (108) when tightening piston against rod.

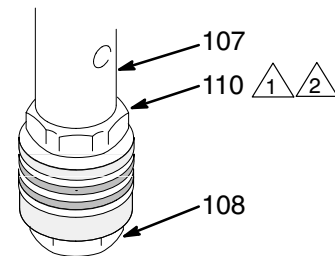

Fig. 21

01071

- Stack these parts one at a time into the top of the manifold (101): the male gland (106*), alternately three plastic packings (104*) with two leather packings (105*), and then the female gland (103*). See Fig. 23.
- Install the packing nut (102) and plug (124), but leave loose for now. See Fig. 23.

Use two wrenches to maintain the alignment mentioned in **NOTE** below Step 3.

Displacement Pump Repair

11. Place a new o-ring (116*) firmly in the cylinder groove. See Fig. 22.
12. Coat the piston rod and packings with oil. Carefully slide the assembly **into the top of the cylinder (115)**. See Fig. 22.
13. Put the manifold upside down in a vise. Fully thread the jam nut (117) onto the cylinder (115). Guide the rod/cylinder assembly down through the manifold (101). Screw the cylinder (115) into the manifold. See Fig. 22.

15. Torque the cylinder jam nut (117) to 73 ft-lb (98 N.m). See Fig. 22.
16. Install the pump. See page 22.

- | | | | |
|---|-----------------------------------|---|---------------------------------|
|  | Leather packings |  | Lips of V-packings must face up |
|  | Poly packings |  | Torque to 53 ft-lb (71 N.m) |
|  | Lips of V-packings must face down | | |

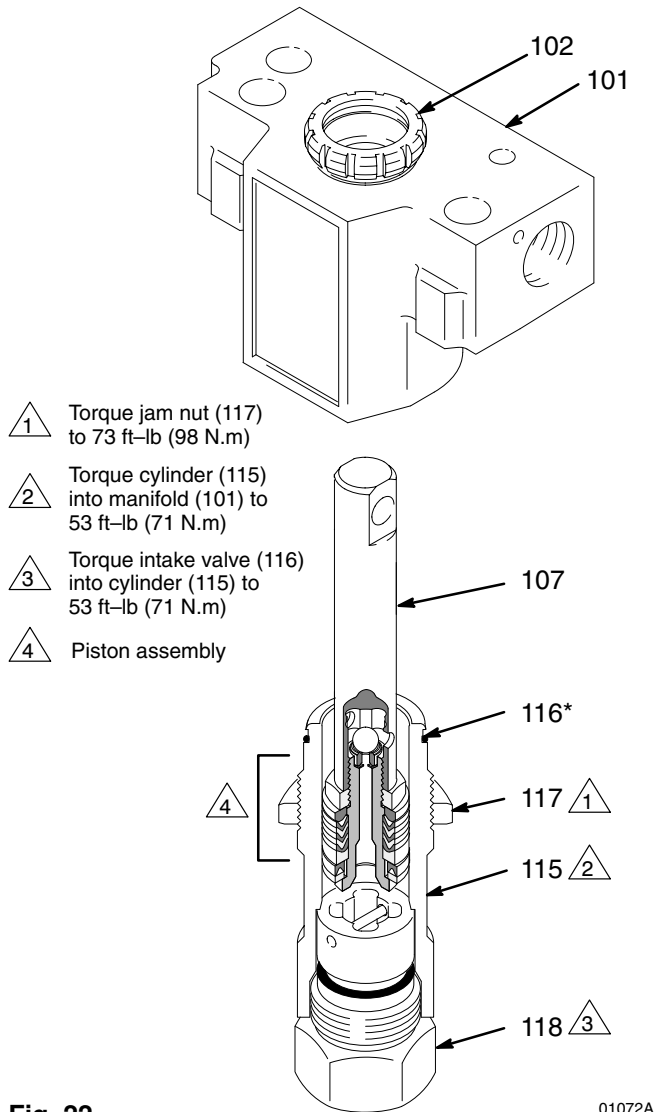

Fig. 22

01072A

14. Place the ball guide (120), stop pin (122) and ball (121*) in the cylinder (115). Screw the intake valve (116) into the cylinder and torque to 53 ft-lb (71 N.m). This will also properly torque the cylinder into the manifold. See Fig. 23.

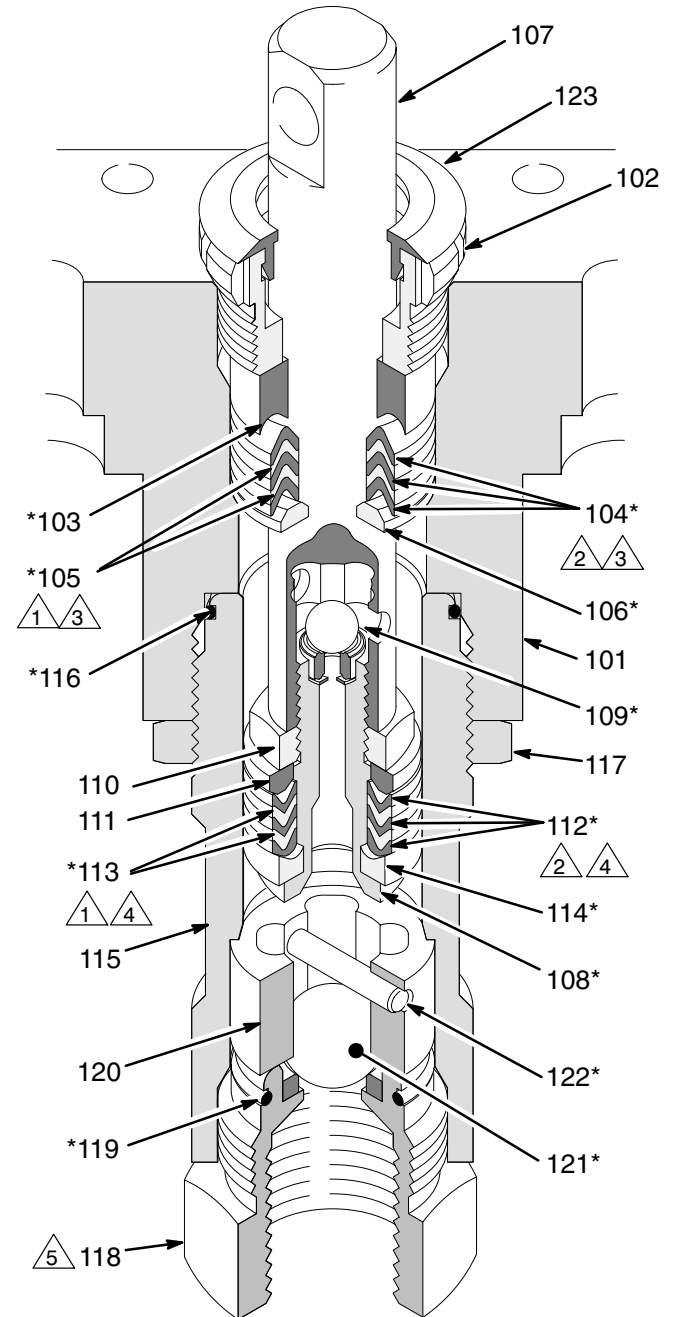

Fig. 23

01073

Motor

⚠ WARNING



INJECTION HAZARD

To reduce the risk of serious injury, whenever you are instructed to relieve pressure, follow the **Pressure Relief Procedure** on page 9.

NOTE: See Fig. 26 except where noted.

1. Relieve pressure.
2. Try to stop the pump with the piston rod (107) in its lowest position. To lower the piston rod manually, rotate the motor fan blades. Use a screwdriver to push the retaining spring (18) up and push out the pin (17). See Fig. 24.
3. Remove the screws (56) and lower the junction box (59). Disconnect the motor wires and the pressure control wire (A) from the motor start board. Refer to Fig. 27 on page 27.
4. Remove the front cover (13).
5. Turn the displacement pump rod (107) so the pin hole aligns with the bottom drive housing screw (19). See Fig. 25. Remove the three drive housing screws and lockwashers (19,6). Also see Fig. 26.
6. Remove the two motor screws (19) and and remove the sprayer handle (24).
7. Tap the lower rear of the drive housing (11) with a plastic mallet to loosen the motor. Pull the drive housing straight off the motor while guiding the harness (A) from the motor. Do not allow the gear (16) to fall. Read the CAUTION on page 28.

8. Remove the two screws (46) and lift the motor off the base (66).
9. Align the new motor with the base and reinstall the screws (46).
10. Assemble the drive housing to the motor. Follow steps 8 to 11 on page 28.
11. Connect the wires in the junction box. Refer to Fig. 27 on page 27. Install the junction box.
12. Connect the piston rod (107) to the drive housing; see page 22, **Installing the Pump**, Step 2 and the WARNING following it.

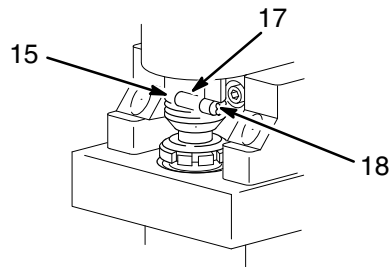

Fig. 24

01068

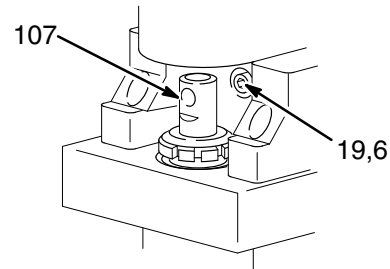

Fig. 25

01074

- 1 Torque to 80 in-lb (9 N.m)
- 2 Quantity of three
- 3 Quantity of one

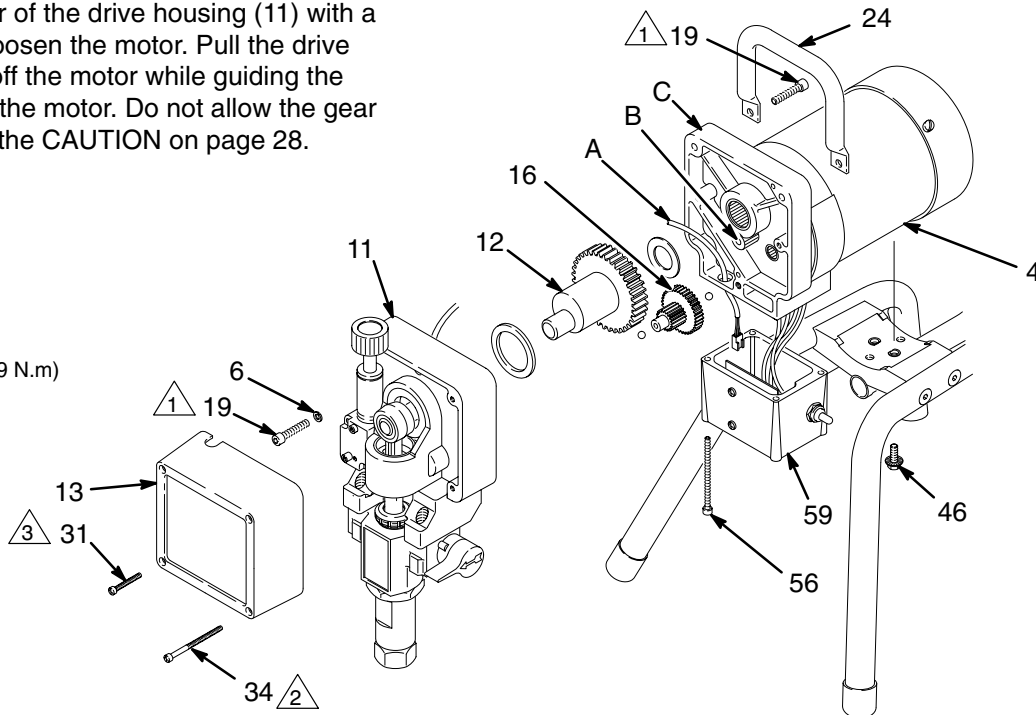

Fig. 26

04656

Motor Start Board

⚠ WARNING



INJECTION HAZARD

To reduce the risk of serious injury, whenever you are instructed to relieve pressure, follow the **Pressure Relief Procedure** on page 9.

Procedure on page 9.

NOTE: See Fig. 27 for this procedure.

1. Relieve pressure.
2. Remove the junction box screws (56) and lower the junction box (59).
3. Disconnect the motor wires (B) and the 3-wire connector (A) from the motor start board (47). Observe where connections are made.
4. Remove the screws (58) and motor start board (47). Transfer the white thermal paste from the old board to the new board.
5. Install the new motor start board. Reconnect all wires. Install the junction box. Be sure no leads are pinched against the motor or by the motor start board. Also be sure the gasket (89) is installed.

⚠ CAUTION

Be sure the flat blade of the insulated male connector is centered in the wrap-around blade of the female connector when the connections are made.

Route all wires carefully to avoid interference with the motor start board or junction box.

These precautions are essential to reduce the risk of a malfunction.

Power Supply Cord

NOTE: See Fig. 27 for this procedure.

1. Relieve pressure.
2. Remove the junction box screws (56) and lower the junction box (59).
3. Disconnect the power supply cord leads, including the green wire to the grounding screw (49).
4. Loosen the strain relief bushing (51). Remove the power supply cord (50).

5. Install the new cord (50) in the reverse order of disassembly.
6. Install the junction box. Be sure no leads are pinched against the motor or by the motor start board. Also be sure the gasket (89) is installed.

On/Off Switch

NOTE: See Fig. 27 for this procedure.

1. Relieve pressure.
2. Remove the junction box screws (56) and lower the junction box (59).
3. Remove the nut and rubber boot (55).
4. Disconnect the black wires from the ON/OFF switch (52) and remove the switch.
5. Place the ring terminal of the ground wire (53) over the barrel of the new switch. Install the switch so the internal tab of the anti-rotation ring (54) engages with the vertical groove in the threads of the switch, and the external tab engages with the blind hole (C) of the junction box.
6. Powder the inside of the rubber boot (55) with talcum, then shake the excess out of the boot. Install the nut and rubber boot and tighten.
7. Reconnect the ON/OFF switch black wires.
8. Install the junction box. Be sure no leads are pinched against the motor or by the motor start board. Also be sure the gasket (89) is installed.

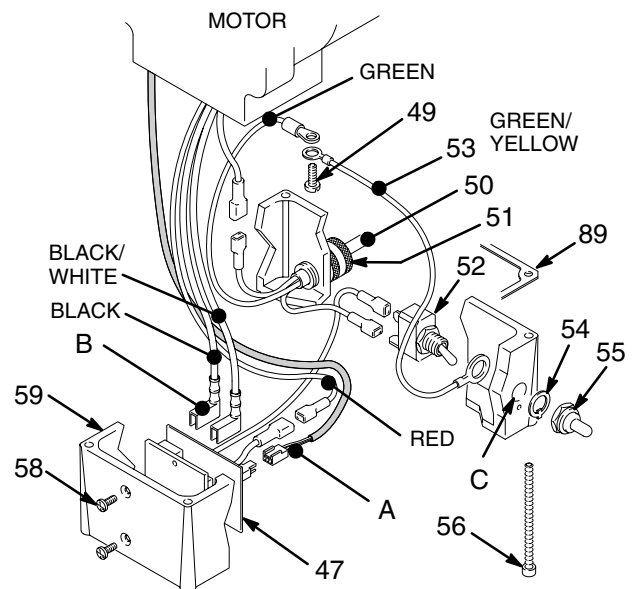

Fig. 27

04720

Drive Housing, Connecting Rod, Crankshaft

⚠ WARNING



INJECTION HAZARD

To reduce the risk of serious injury, whenever you are instructed to relieve pressure, follow the **Pressure Relief Procedure** on page 9.

NOTE: Inspect parts as they are removed. Replace parts that are worn or damaged.

1. Remove the displacement pump. See page 22.
2. Remove the pressure control (64). See page 30.
3. Turn the displacement pump rod (107) so the pin hole aligns with the bottom drive housing screw (19). See Fig. 28. Remove the three drive housing screws and lockwashers (19,6). Also see Fig. 29 on page 29.

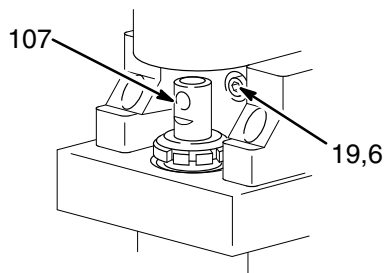

Fig. 28

01074

4. Remove the two motor screws (19) and handle (24). See Fig. 29 on page 29.
5. Tap the lower rear of the drive housing (11) with a plastic mallet to loosen the motor. Pull the drive housing straight off the motor.

⚠ CAUTION

Do not allow the gear (16) to fall; it may stay attached to the drive housing or to the motor.

Do not lose the thrust balls (11a or 4a) or let them fall between the gears, which will damage the drive housing if not removed. The balls, which are heavily covered with grease, usually stay in the gear recesses, but could be dislodged. If the balls are not in place, the bearings will wear prematurely.

6. Remove and inspect the crankshaft (12) and the connecting rod (15).
7. Install the connecting rod.
8. Lubricate the inside of the drive housing bearing with SAE non-detergent oil. Pack the roller bearing and gears with the grease supplied.

NOTE: The gears and bearings between the drive housing (11) and motor front end bell (C) should contain a total of 3 fl. oz. (29 cc) of grease.

9. Route the wire harness (A) through the motor passages to the junction box (59).
10. Place the large washer (12a) and then the small washer (12b) on the crankshaft (12).
11. Lift the crank to the top of the stroke and insert crankshaft (12). Align the gears and push the drive housing (11) straight onto the motor and the locating pins. Install the screws (19, 5) and their lockwashers (6). Torque to 80 in-lb (9 N.m).
12. Install the displacement pump. See page 22.
13. Install the pressure control (64). See page 30. Install the front cover (13).

Drive Housing, Connecting Rod, Crankshaft

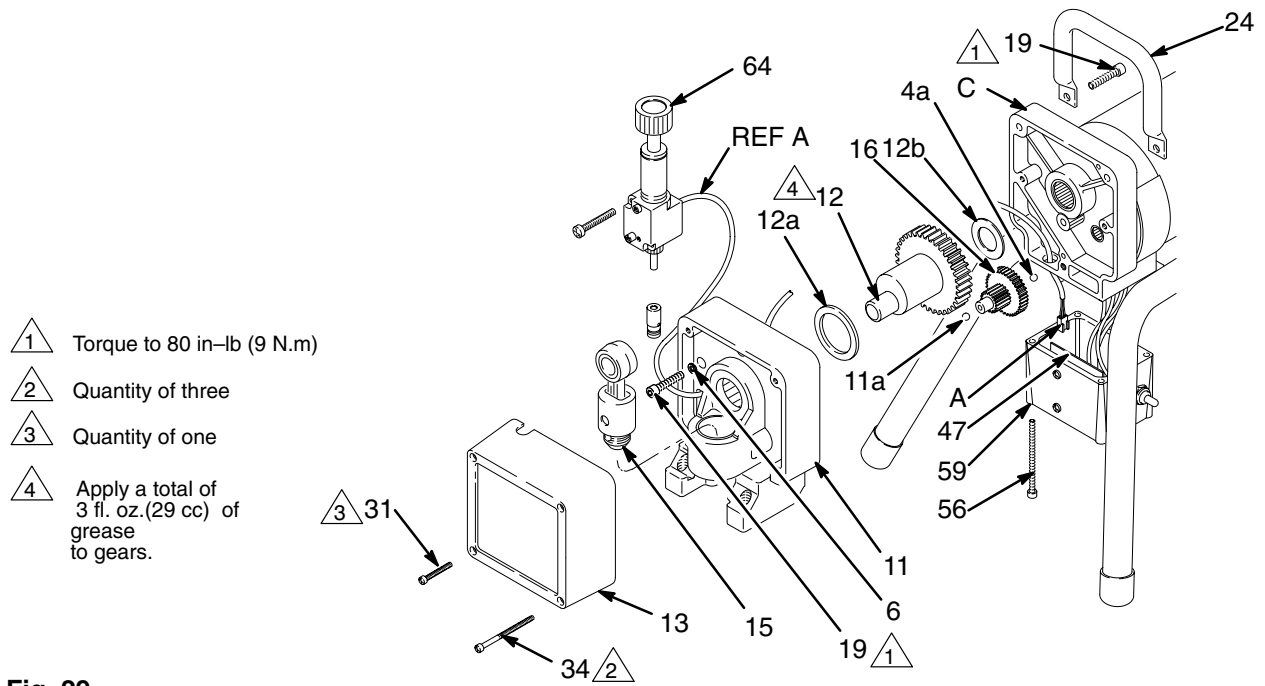
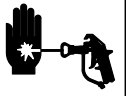

Fig. 29

04657

Pressure Control

⚠ WARNING



INJECTION HAZARD

To reduce the risk of serious injury, whenever you are instructed to relieve pressure, follow the **Pressure Relief Procedure** on page 9.

- Loosely install the screws (63) and then torque them to 21 in-lb (2.4 N.m).
- Install the front cover (13). Connect the harness (A) to the motor start board (47).
- Install the junction box. Be sure no leads are pinched against the motor or by the motor start board.

NOTE: See Fig. 30 for this procedure.

NOTE: The pressure control (64) cannot be repaired or adjusted. If it has malfunctioned, replace it.

- Remove the front cover (13). Remove the screws (56). Lower the junction box (59).
- Disconnect the harness connector (A) from the motor start board (47).
- Remove the screws (63). Pull forward on the pressure adjusting knob and tip the pressure control (64) forward and up to detach it from the drive housing (11).
- Guide the harness (A) through the motor and drive housing and remove the pressure control.
- Guide the harness of the new pressure control through the drive housing and motor passages.
- Install the new pressure control. Tip the pressure control down and back into the drive housing (11). Do not pinch or damage the harness (A).

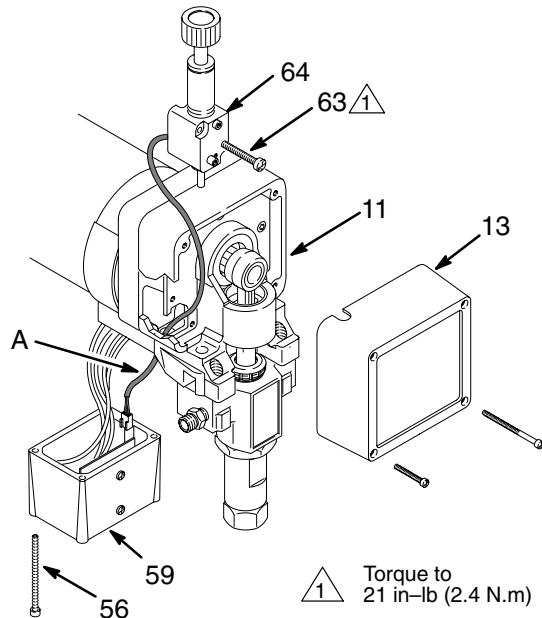



Fig. 30

02816A

Pressure Transducer

⚠ WARNING	
	INJECTION HAZARD To reduce the risk of serious injury, whenever you are instructed to relieve pressure, follow the Pressure Relief Procedure on page 9.

NOTE: See Fig. 31 for this procedure.

1. Remove the displacement pump. See page 22.
2. Use a pull–twist motion to remove the transducer (29) from the pump manifold (101).
3. Clean paint residue from the hole in the manifold; do not scratch the surface of the hole.
4. Lightly apply oil to the o-ring of the new transducer.
5. Install the transducer in the pump manifold, while guiding the o-ring and backup ring into place.
6. Align the holes in the transducer as shown by the arrows in Fig. 31.
7. Install the displacement pump. See page 22.

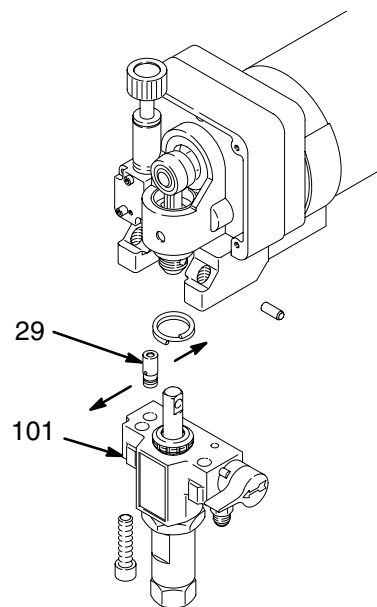
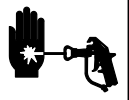

Fig. 31

02817A

Drain Valve

⚠ WARNING



INJECTION HAZARD

To reduce the risk of serious injury, whenever you are instructed to relieve pressure, follow the **Pressure Relief Procedure** on page 9.

Procedure on page 9.

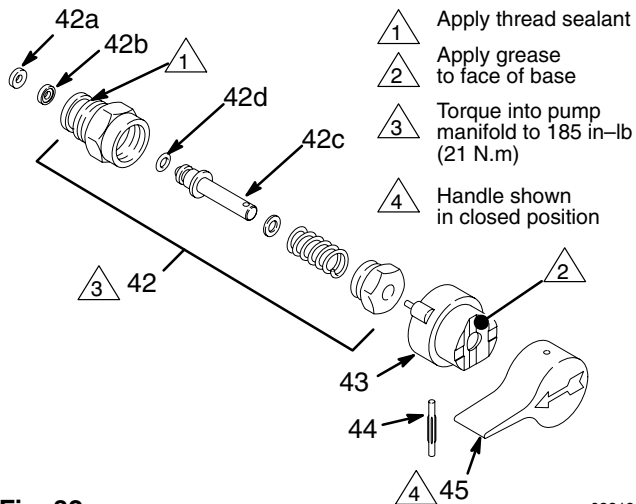

Fig. 32 _____ 02819

1. Turn the handle (45) to the closed position. Drive out the pin (44). Remove the handle.
2. Remove the base (43).
3. Unscrew the drain valve (42). The gasket (42a) and seat (42b) will stay in the valve.

Repair

1. Unscrew the spring retainer from the valve body. Remove the spring, washers and stem/ball. Clean any debris from the ball or seat area.
2. If replacing the gasket (42a) or seat (42b), pry out the gasket.

NOTE: Whenever the gasket (42a) is removed, replace it with a new one.

3. Coat the o-ring (42d) with grease. Press the stem into the valve body. Install the spring, washers and spring retainer into the valve body.
4. Place the seat (42b) in the valve body so the lapped side is toward the ball. Apply a small amount of grease to the new gasket (42a) and install it in the valve body.

NOTE: The gasket will protrude from the end of the valve until the valve is tightened into pump, which correctly seats the gasket.

Replacement

1. Apply a small amount of thread sealant (42e) onto the valve (42) threads. Tighten the valve into the pump manifold to 185 in-lb (21 N.m).
2. Lightly grease the face of the base (43) and install the base. Turn the stem so the pin hole is vertical.
3. Securely install the handle (45) and drive pin (44).

Inlet Strainer Installation/Removal

Installation (Fig. 33)

1. Align the keyway in the strainer (39) with the small nub near the end of the suction tube (32).
2. Push the strainer over the nub and up to the suction tube's raised band. While holding the strainer against the band, rotate it about 1/2 turn in either direction (a wrench may be necessary).

Removal

1. With a wrench or the hand, turn the strainer (39) in either direction until the keyway aligns with the raised nub in the suction tube (32). A sudden release in turning resistance will be felt when the parts align.
2. Pull, or tap, the strainer straight off the suction tube.

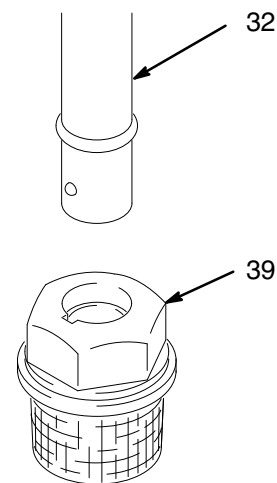

Fig. 33 _____ 04717

Displacement Pump Parts Drawing and List

Model 236-787, Series A

Includes items 101 to 127

Ref No.	Part No.	Description	Qty
101	187-611	MANIFOLD, pump	1
102	176-758	PACKING NUT	1
103*	176-757	GLAND, female, throat	1
104*	176-997	V-PACKING, plastic, throat	3
105*	176-755	V-PACKING, leather, throat	2
106*	176-754	GLAND, male, throat	1
107	187-613	DISPLACEMENT ROD	1
108	224-808	PISTON VALVE	1
109*	105-444	BALL, 5/16", piston	1
110	176-751	NUT, hex, 1/2-20 unef-2b	1
111*	176-750	GLAND, male, piston	1
112*	176-882	V-PACKING, plastic, piston	3
113*	176-749	V-PACKING, leather, piston	2
114*	180-073	GLAND, female, piston	1
115	236-786	CYLINDER, pump	1
116*	108-526	PACKING, o-ring, PTFE®	1
117	187-614	NUT, jam, 1-3/8 18 unef-2b	1
118	224-966	INLET VALVE	1
119*	111-603	PACKING, o-ring, PTFE®	1
120	176-760	GUIDE, ball	1
121*	105-445	BALL, 1/2", inlet	1
122*	176-759	PIN, ball stop	1
123	180-656	PLUG	1
124*	102-969	SEALANT (not shown)	1
127▲	188-663	LABEL, Warning	1

*Supplied in Repair Kit 235-703.

Keep a repair kit on hand to reduce down time.

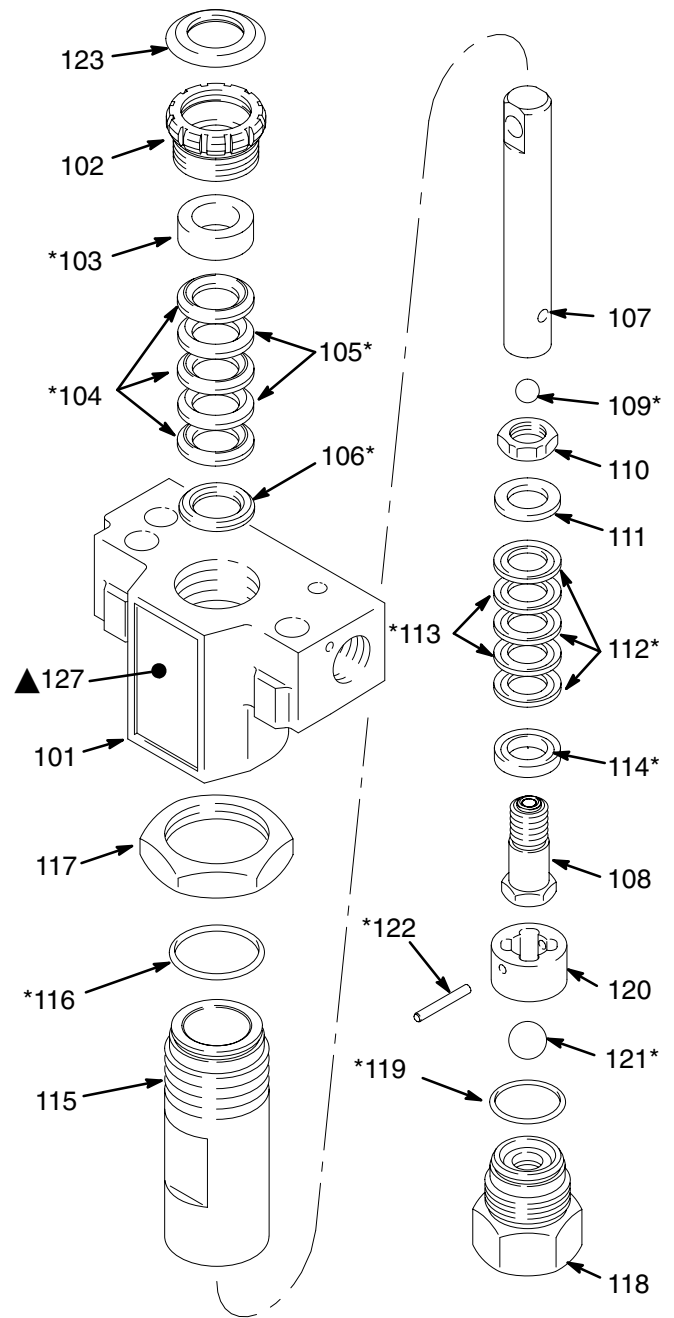

01069A

Accessories

Fluid Filter Kit 235-677

Filters particles from fluid stream. Includes manifold filter, fittings and installation instructions.

Upright Cart Kit 236-328

Converts sprayer to tall wheeled cart.

Low Profile Cart Kit 235-710

Converts sprayer to low profile wheeled cart.

Sprayer Parts Drawing

Model 231-344, Series A

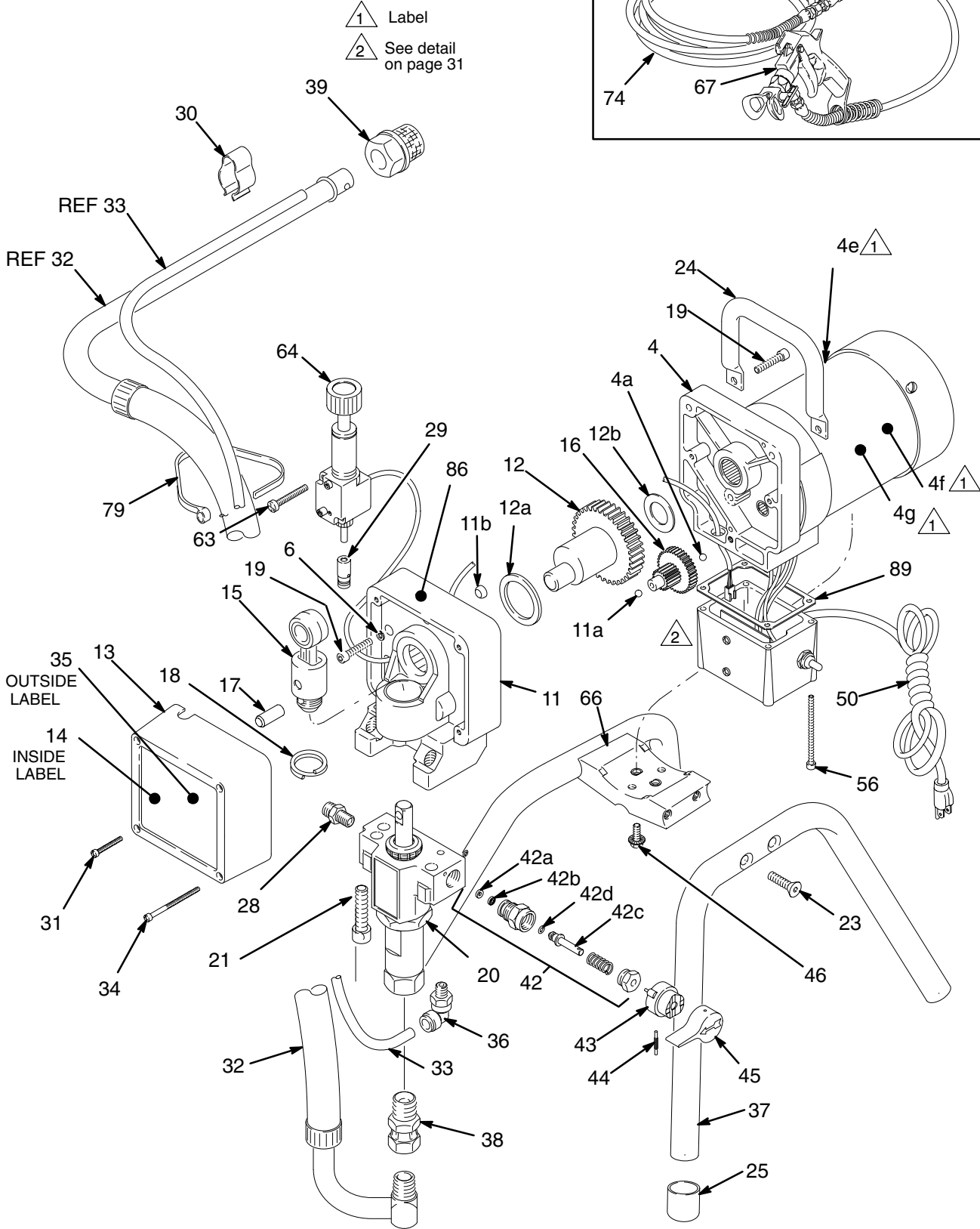
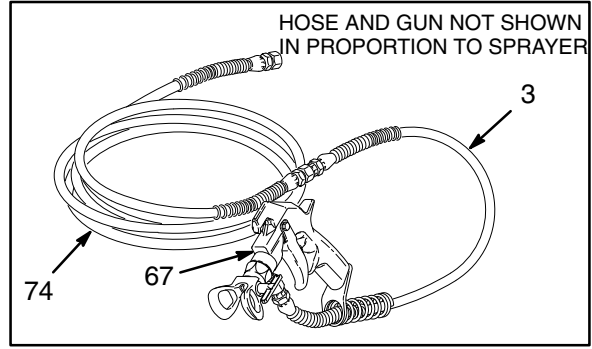

O4658

Sprayer Parts List

Model 231-344, Series A

Includes items 3 to 89 as listed below

Ref. No.	Part No.	Description	Qty.	Ref. No.	Part No.	Description	Qty.
3	214-701	HOSE, grounded, 3/16" x 3 ft	1	44	111-600	PIN, grooved, 3/32 x 1"	1
4†	237-461	MOTOR KIT <i>Includes items 4a to 4g</i>	1	45	187-625	HANDLE, drain valve	1
4a.	100-069	.BALL, sst, 1/4" dia.	1	46	110-997	SCREW, washer/hex hd, 5/16"	2
4b.	111-616	.TERMINAL, flat, 1/4" (f), 18 awg	2	47	235-008	MOTOR START BOARD	1
4c.	107-503	.TERMINAL, 3/16" (m), 16 awg	1	48▲	186-620	LABEL, ground terminal	1
4d.	107-267	.TERMINAL, 3/16" (f)	1	49	110-037	SCREW, mach, pnhd, 10-24 x 5/8"	1
4e.▲	187-784	.LABEL, DANGER, French	1	50	235-010	POWER CORD SET	1
4f.▲	187-791	.LABEL, DANGER, English	1	51	111-617	STRAIN RELIEF BUSHING, 3/8-18 npt	1
4g.▲	187-975	.LABEL, WARNING, electric shock	1	52	105-679	SWITCH, ON/OFF	1
6	105-510	LOCKWASHER, 1/4"	3	53	235-035	GROUND HARNESS	1
11	235-171	DRIVE HOUSING KIT <i>Includes item 11a, 11b</i>	1	54	105-658	LOCKING RING	1
11a	100-069	.BALL, stainless steel, 1/4" dia.	1	55	105-659	BOOT, switch	1
11b	111-726	.PLUG	1	56	111-703	SCREW, filh, 10-24 x 3"	4
12	224-803	CRANKSHAFT <i>Includes items 12a, 12b</i>	1	58	100-035	SCREW, pan hd, 8-32 x 5/16"	2
12a	180-131	.BEARING, thrust	1	59	187-795	JUNCTION BOX	1
12b	107-434	.BEARING	1	63	111-704	SCREW, filh, 10-24 x 1-5/8"	2
13	187-942	COVER, front	1	64	224-828	PRESSURE CONTROL KIT	1
14▲	177-762	LABEL, WARNING	1	66	189-932	BASE, motor	1
15	218-359	CONNECTING ROD	1	67	235-459	FLEX GUN <i>See manual 308-235 for parts</i>	1
16	218-364	GEAR REDUCER	1	68	206-994	TSL, 8 oz. (not shown)	1
17	176-818	PIN, headless, 3/8" dia. x 1"	1	74	223-541	HOSE, grounded, nylon; 1/4" ID; cpld 1/4 npsm(f); 50 ft (15 m); spring guards both ends	1
18	176-817	SPRING, retaining	1	79	103-473	STRAP, tie	2
19	103-345	SCREW, socket head, 1/4-20 x 1-1/4"	5	86	290-105	LABEL, ID, drive housing	1
20	236-787	PUMP KIT <i>see parts on page 29</i>	1	89	187-963	GASKET	1
21	111-706	CAPSCREW, 7/16-14 x 1-3/4"	2				
23	111-715	SCREW, 5/16-18 x 1-1/4"	4				
24	190-337	HANDLE, sprayer	1				
25	112-759	CAP, tubing	4				
28	162-453	NIPPLE, hex, 1/4 npsm x 1/4 npt, 1-3/16"	2				
29	235-009	PRESSURE TRANSDUCER	1				
30	190-464	CLIP, 5/8"	1				
31	108-850	SCREW, filh, 8-32 x 1-1/4"	1				
32	237-684	SUCTION HOSE & TUBE	1				
33	190-336	DRAIN TUBE	1				
34	111-705	SCREW, filh, 8-32 x 2-1/2"	3				
35	290-104	LABEL, identification	1				
36	237-696	ELBOW, drain	1				
37	190-334	LEG, sprayer	2				
38	190-451	ADAPTER, union	1				
39	237-820	STRAINER	1				
42	235-014	DRAIN VALVE KIT <i>Includes items 42a to 42e</i>	1				
42a	111-699	.GASKET, valve seat	1				
42b	187-615	.SEAT, drain valve	1				
42c	224-968	.STEM, drain valve	1				
42d	168-110	.O-RING, stem	1				
42e	110-110	.SEALANT, pipe (not shown)	1				
43	224-807	BASE, valve	1				

▲ Extra warning labels available free of charge.

† Motor Brush and Spring Replacement Kit, P.N.236-967 is available. Purchase separately.

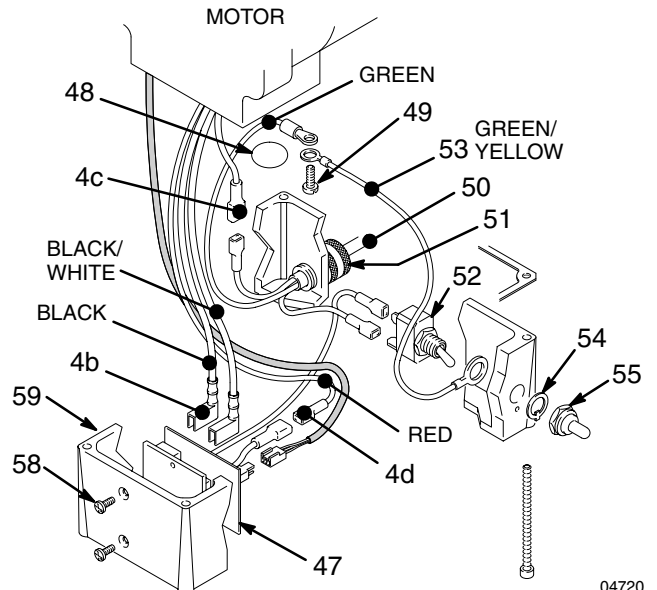

04720

Technical Data

Power Requirements	120 VAC, 60 Hz, 1 phase, 15 amp minimum
Generator	3000 Watt minimum
Working Pressure Range	0–2750 psi (0 – 195 bar)
Motor	1/2 hp
Cycles/Gallon (liter)	620 (164)
Delivery	0.33 gpm (1.25 lpm)
Tip Size	one gun to 0.019 new tip with latex at 2000 psi (138 bar)
Power Cord	No. 14 AWG, 3 wire, 6' (1.8 m)
Inlet Paint Strainer	12 mesh (1525 micron) Stainless Steel Screen, reusable
Pump Inlet Size	1/2 npt(f)
Fluid Outlet Size	1/4 npsm
Wetted Parts:	
Displacement Pump	Stainless steel, Carbon steel, PTFE®, Aluminum, Polyethylene, Delrin®, Leather

NOTE: PTFE and Delrin are trademarks of the Company.

Dimensions

Weight (dry w/o packaging)	35 lb (16 kg)
Height	18 in. (457 mm)
Length	15 in. (381 mm)
Width	12.5 in. (318 mm)

The Graco Warranty and Disclaimers

WARRANTY

Graco warrants all equipment manufactured by it and bearing its name to be free from defects in material and workmanship on the date of sale by an authorized Graco distributor to the original purchaser for use. As purchaser's sole remedy for breach of this warranty, Graco will, for a period of twelve months from the date of sale, repair or replace the electric motor or any other part of the equipment proven defective, with the exception of defects in parts on the drive train/gear box on EM and GM sprayers or power train on EH and GH sprayers, which will be repaired or replaced for twenty-four months from the date of sale for Gas-Hydraulic (GH) and Gas-Mechanical (GM) sprayers and for thirty-six months from the date of sale for Electric-Mechanical (EM), Electric-Hydraulic (EH), 301sts, 390st and 490st sprayers. This warranty applies only when the equipment is installed, operated and maintained in accordance with Graco's written recommendations.

This warranty does not cover, and Graco shall not be liable for, any malfunction, damage or wear caused by faulty installation, misapplication, abrasion, corrosion, inadequate or improper maintenance, negligence, accident, tampering, or substitution of non-Graco component parts. Nor shall Graco be liable for malfunction, damage or wear caused by the incompatibility with Graco equipment of structures, accessories, equipment or materials not supplied by Graco, or the improper design, manufacture, installation, operation or maintenance of structures, accessories, equipment or materials not supplied by Graco.

This warranty is conditioned upon the prepaid return of the equipment claimed to be defective to an authorized Graco distributor for verification of the claim. If the claimed defect is verified, Graco will repair or replace free of charge any defective parts. The equipment will be returned to the original purchaser transportation prepaid. If inspection of the equipment does not disclose any defect in material or workmanship, repairs will be made at a reasonable charge, which charges may include the costs of parts, labor and transportation.

DISCLAIMERS AND LIMITATIONS

The terms of this warranty constitute purchaser's sole and exclusive remedy and are in lieu of any other warranties (express or implied), **including warranty of merchantability or warranty of fitness for a particular purpose**, and of any non-contractual liabilities, including product liabilities, based on negligence or strict liability. Every form of liability for direct, special or consequential damages or loss is expressly excluded and denied. In no case shall Graco's liability exceed the amount of the purchase price. Any action for breach of warranty must be brought within two (2) years of the date of sale.

EQUIPMENT NOT COVERED BY GRACO WARRANTY

Graco makes no warranty, and disclaims all implied **warranties of merchantability and fitness for a particular purpose**, with respect to accessories, equipment, materials, or components sold but not manufactured by Graco. These items sold, but not manufactured by Graco (such as electric motor, switches, hose, etc.) are subject to the warranty, if any, of their manufacturer. Graco will provide purchaser with reasonable assistance in making any claim for breach of these warranties.

Sales Offices: Atlanta, Chicago, Dallas, Detroit, Los Angeles, Mt. Arlington (N.J.)
Foreign Offices: Canada; England; Korea; Switzerland; France; Germany; Hong Kong; Japan

GRACO INC. P.O. BOX 1441 MINNEAPOLIS, MN 55440-1441

PRINTED IN U.S.A. 308-569 3/95

DANGER LABELS

The English language DANGER label shown on page 4 is also on your sprayer. If you have painters who do not read English, order one of the following labels to apply to your sprayer. The drawing below shows the best placement of these labels for good visibility.

Order the labels directly from Graco, free of charge: 1-800-328-0211

French	185-956
Spanish	185-961
German	186-041
Greek	186-045
Korean	186-049
English	185-953

Apply other language here

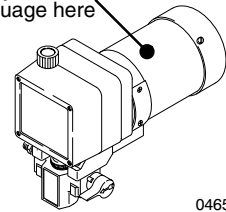

04653

Graco Phone Numbers

TO PLACE AN ORDER, contact your Graco distributor, or call this number to identify the distributor closest to you: **1-800-367-4023 Toll Free**

FOR TECHNICAL ASSISTANCE, service repair information or assistance regarding the application of Graco equipment: **1-800-543-0339 Toll Free**