

# INSTRUCTIONS-PARTS LIST



308-551



This manual contains important warnings and information.  
**READ AND KEEP FOR REFERENCE.**

INSTRUCTIONS

First choice when quality counts.™

Rev. G  
Supersedes D  
and PCN E

120 VAC, 18A

## ULTRA® Plus+ 1500

# Airless Paint Sprayer

3000 psi (21.0 MPa, 210 bar) Maximum Working Pressure

**Part No. 223-773, Series A**

Basic Sprayer on upright cart, CSA certified

Patents Pending

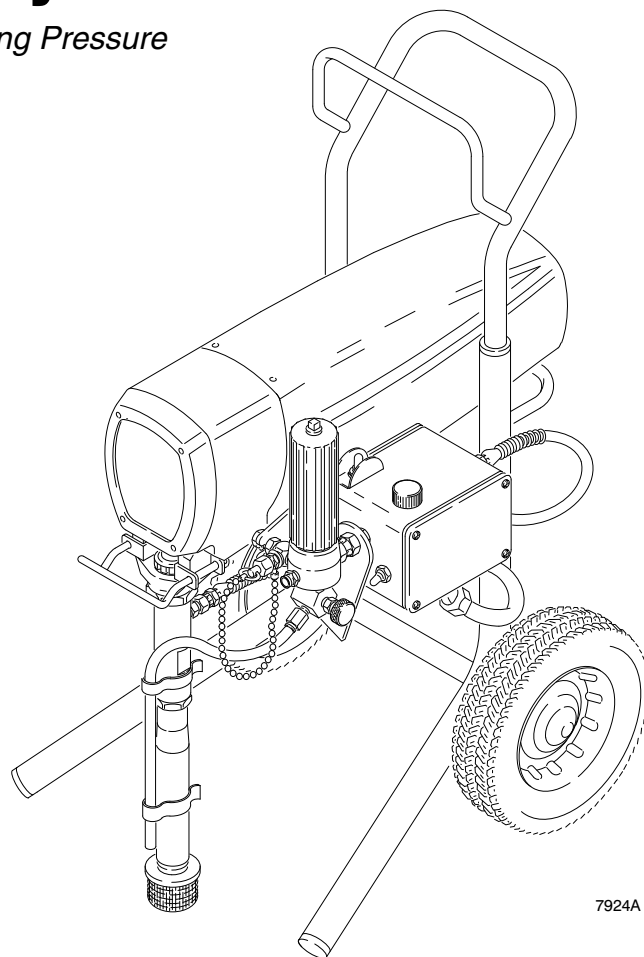

7924A

GRACO INC. P.O. BOX 1441 MINNEAPOLIS, MN 55440-1441

<http://www.graco.com>

©COPYRIGHT 1994, GRACO INC.

Graco Inc. is registered to I.S. EN ISO 9001

# Table of Contents

|                         |    |  |    |
|-------------------------|----|--|----|
| Warnings .....          | 2  | Bearing Housing & Connecting Rod .....         | 20 |
| Setup .....             | 6  | Drive Housing .....                            | 21 |
| Operation .....         | 7  | Sprayer Parts Drawing .....                    | 22 |
| Flushing .....          | 9  | Sprayer Parts List .....                       | 23 |
| Troubleshooting .....   | 10 | Displacement Pump Parts Drawing and List ..... | 24 |
| Motor Brush .....       | 12 | Accessories .....                              | 25 |
| Displacement Pump ..... | 13 | Technical Data .....                           | 27 |
| Pressure Control .....  | 18 | Dimensions .....                               | 27 |
| Power Supply Cord ..... | 18 | Graco Warranty .....                           | 28 |
| Motor .....             | 19 | Phone Number .....                             | 28 |

## Symbols

### Warning Symbol



This symbol alerts you to the possibility of serious injury or death if you do not follow the instructions.

### Caution Symbol



This symbol alerts you to the possibility of damage to or destruction of equipment if you do not follow the instructions.

## ! WARNING



INSTRUCTIONS

### EQUIPMENT MISUSE HAZARD

Equipment misuse can cause the equipment to rupture or malfunction and result in serious injury.

- This equipment is for professional use only.
- Read all instruction manuals, tags, and labels before operating the equipment.
- Use the equipment only for its intended purpose. If you are not sure, call Graco Technical Assistance at 1-800-543-0339.
- Do not alter or modify this equipment.
- Check equipment daily. Repair or replace worn or damaged parts immediately.
- Do not exceed the maximum working pressure of the lowest rated system component. Refer to the **Technical Data** on page 27 for the maximum working pressure of this equipment.
- Use fluids and solvents which are compatible with the equipment wetted parts. Refer to the **Technical Data** section of all equipment manuals. Read the fluid and solvent manufacturer's warnings.
- Do not use hoses to pull equipment.
- Route hoses away from traffic areas, sharp edges, moving parts, and hot surfaces. Do not expose Graco hoses to temperatures above 82°C (180°F) or below -40°C (-40°F).
- Do not lift pressurized equipment.
- Comply with all applicable local, state, and national fire, electrical, and safety regulations.

# WARNING



## INJECTION HAZARD

Spray from the gun, leaks or ruptured components can inject fluid into your body and cause extremely serious injury, including the need for amputation. Fluid splashed in the eyes or on the skin can also cause serious injury.

- Fluid injected into the skin is a serious injury. The injury may look like just a cut, but it is a serious injury. Get immediate medical attention.
- Do not point the gun at anyone or at any part of the body.
- Do not put your hand or fingers over the spray tip.
- Do not stop or deflect leaks with your hand, body, glove or rag.
- Do not “blow back” fluid; this is not an air spray system.
- Always have the tip guard and the trigger guard on the gun when spraying.
- Check the gun diffuser operation weekly. Refer to the gun manual.
- Be sure the gun trigger safety operates before spraying.
- Lock the gun trigger safety when you stop spraying.
- Follow the **Pressure Relief Procedure** on page 10 if the spray tip clogs and before cleaning, checking or servicing the equipment.
- Tighten all fluid connections before operating the equipment.
- Check the hoses, tubes, and couplings daily. Replace worn or damaged parts immediately. Do not repair high pressure couplings; you must replace the entire hose.
- Fluid hoses must have spring guards on both ends, to help protect them from rupture caused by kinks or bends near the couplings.



## TOXIC FLUID HAZARD

Hazardous fluid or toxic fumes can cause serious injury or death if splashed in the eyes or on the skin, inhaled, or swallowed.

- Know the specific hazards of the fluid you are using.
- Store hazardous fluid in an approved container. Dispose of hazardous fluid according to all local, state and national guidelines.
- Always wear protective eyewear, gloves, clothing and respirator as recommended by the fluid and solvent manufacturer.

# ⚠ WARNING



## FIRE AND EXPLOSION HAZARD

Improper grounding, poor ventilation, open flames or sparks can cause a hazardous condition and result in a fire or explosion and serious injury.



- If there is any static sparking or you feel an electric shock while using this equipment, **stop spraying immediately**. Do not use the equipment until you identify and correct the problem.
- Provide fresh air ventilation to avoid the buildup of flammable fumes from solvents or the fluid being sprayed.
- Keep the spray area free of debris, including solvent, rags, and gasoline.
- Electrically disconnect all equipment in the spray area.
- Extinguish all open flames or pilot lights in the spray area.
- Do not smoke in the spray area.
- Do not turn on or off any light switch in the spray area while operating or if fumes are present.
- Do not operate a gasoline engine in the spray area.



## MOVING PARTS HAZARD

Moving parts can pinch or amputate your fingers.

- Keep clear of all moving parts when starting or operating the pump.
- Before servicing the equipment, follow the **Pressure Relief Procedure** on page 10 to prevent the equipment from starting unexpectedly.

**NOTE:** This is an example of the DANGER label on your sprayer. This label is available in other languages, free of charge. See page 25 to order.

| <span style="float: left;">⚠</span> <span style="font-size: 2em; font-weight: bold; margin: 0 20px;">DANGER</span> <span style="float: right;">⚠</span>   |  |  |                              |
|---|--|--|------------------------------|
|   | <b>FIRE AND EXPLOSION HAZARD</b>   |  | <b>SKIN INJECTION HAZARD</b> |
| <p>Spray painting, flushing or cleaning equipment with flammable liquids in confined areas can result in fire or explosion.</p> <p>Use outdoors or in extremely well ventilated areas. Ground equipment, hoses, containers and objects being sprayed.</p> <p>Avoid all ignition sources such as static electricity from plastic drop cloths, open flames such as pilot lights, hot objects such as cigarettes, arcs from connecting or disconnecting power cords or turning light switches on and off.</p> <p>Failure to follow this warning can result in death or serious injury.</p> | <p>Liquids can be injected into the body by high pressure airless spray or leaks – especially hose leaks.</p> <p>Keep body clear of the nozzle. Never stop leaks with any part of the body. Drain all pressure before removing parts. Avoid accidental triggering of gun by always setting safety latch when not spraying.</p> <p>Never spray without a tip guard.</p> <p>In case of accidental skin injection, seek immediate “Surgical Treatment”.</p> <p>Failure to follow this warning can result in amputation or serious injury.</p> | <b>READ AND UNDERSTAND ALL LABELS AND INSTRUCTION MANUALS BEFORE USE</b> |                              |

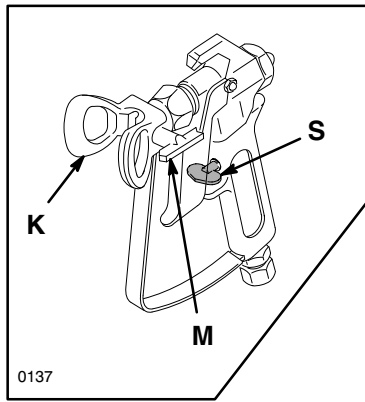

## Major Components

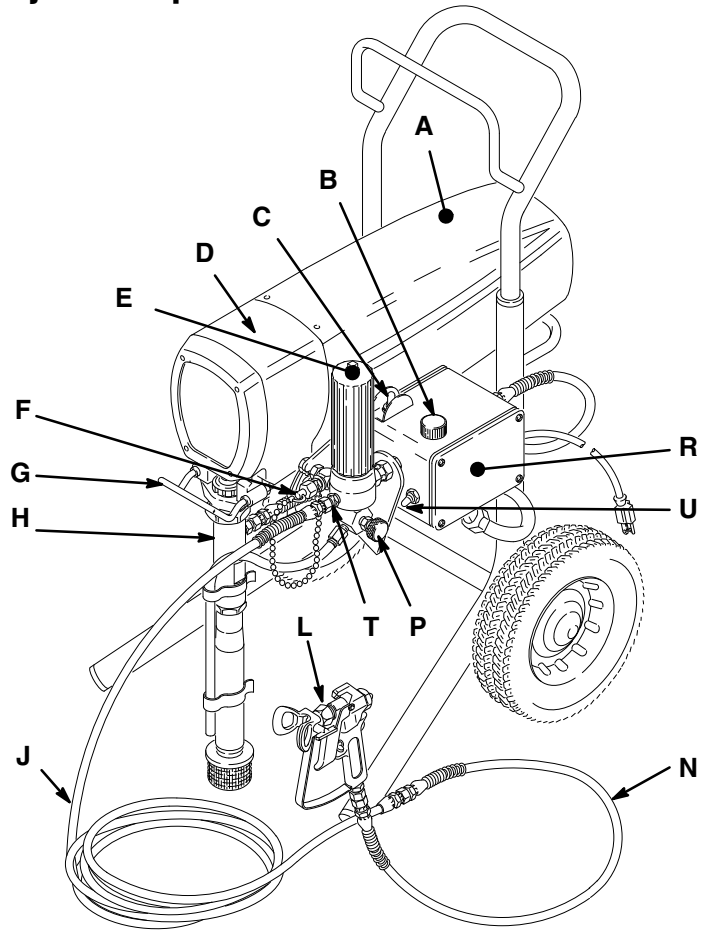

Fig. 1

01888

|          |                                |   |
|----------|--------------------------------|---|
| <b>A</b> | Motor (Under shield shown)     | DC motor, 120 Vac, 18A, 1 phase   |
| <b>B</b> | Pressure Adjusting Knob        | Controls fluid outlet pressure  |
| <b>C</b> | ON/OFF Switch, Circuit Breaker | Power switch that controls 120 Vac power to sprayer; with circuit breaker                                       |
| <b>D</b> | Drive Assembly                 | Transfers power from DC motor to the displacement pump  |
| <b>E</b> | Fluid Filter                   | Filter of fluid between source and spray gun  |
| <b>F</b> | Secondary Fluid Outlet         | Second hose and spray gun is connected here   |
| <b>G</b> | Pail Hanger                    | Container of fluid to be sprayed may be hung here   |
| <b>H</b> | Displacement Pump              | Pressures fluid to be sprayed through spray gun   |
| <b>J</b> | 50 ft (15 m) Main Hose         | 1/4 in. ID, grounded, nylon hose with spring guards on both ends  |
| <b>K</b> | RAC IV Tip Guard               | Reverse-A-Clean (RAC) tip guard reduces the risk of fluid injection injury                                      |
| <b>L</b> | Contractor Gun                 | High pressure spray gun with gun safety latch   |
| <b>M</b> | RAC IV Switch Tip              | RAC switch tip atomizes fluid and removes clogs from spray tip without removing tip from spray gun              |
| <b>N</b> | 3 ft (0.9 m) Hose              | 3/16 in. ID, grounded, nylon hose used between 50 ft hose and spray gun to allow more flexibility when spraying |
| <b>P</b> | Pressure Drain Valve           | Relieves fluid pressure when open   |
| <b>R</b> | Pressure Control               | Controls motor speed to maintain fluid pressure. Works with pressure adjusting knob.                            |
| <b>S</b> | Spray Gun Safety Latch         | Inhibits accidental triggering of spray gun   |
| <b>T</b> | Primary Fluid Outlet           | Hose and spray gun is connected here  |
| <b>U</b> | 15/20 Amp Switch               | Allows sprayer to operate on 15A service with reduced performance   |

# Setup

## ⚠ WARNING

If you supply your own hoses and spray gun, be sure the hoses are electrically conductive, that the gun has a tip guard, and that each part is rated for at least *3000 psi (21.0 MPa, 210 bar) Working Pressure*. This is to reduce the risk of serious injury caused by static sparking, fluid injection or over-pressurization and rupture of the hose or gun.

## ⚠ CAUTION

To avoid damaging the pressure control, which may result in poor equipment performance and component damage, follow these precautions:

1. Always use a nylon spray hose at least 50 ft. (15 m) long.
2. Never use a wire braid hose as it is too rigid to act as a pulsation dampener.
3. Never install any shutoff device between the filter and the hose. See Fig. 2.

1. **Assemble the gun (L), 3 ft. whip hose (N) and 50 ft. hose (J).** Don't install the spray tip and tip guard yet.
2. **Two gun hookup.** Remove the cap (12) from the 1/4 npsm(m) secondary hose outlet and attach a minimum 50 ft. long hose. For more flexible gun movement, install a 3/16 in. ID, 3 ft. whip hose between the main hose and the gun.
3. **Fill the packing nut/wet-cup (216) 1/3 full with Graco Throat Seal Liquid (TSL), supplied.**

## ⚠ WARNING



### FIRE AND EXPLOSION HAZARD

Proper electrical grounding is essential to reduce the risk of fire or explosion which can result in serious injury and property damage. Also read **FIRE OR EXPLOSION HAZARD** on page 4.

4. **Check the electrical service.** Be sure the electrical service is 120 VAC, 60 Hz, 20A. Use a properly grounded outlet. Do not remove the grounding prong of the power supply cord. Do not use an adapter. Extension cords must have 3 wires of a minimum 12 gauge size. Long extension cords reduce sprayer performance. If 20A service is not available, flip the 15/20 Amp switch (U) to 15 setting to avoid nuisance tripping of circuit breakers.
5. **With the the ON/OFF switch OFF, plug the cord into a grounded electrical outlet** located at least 20 ft. (6 m) away from the spray area.
6. **Flush the pump** to remove the lightweight oil which was left in to protect pump parts after factory testing. See page 9.

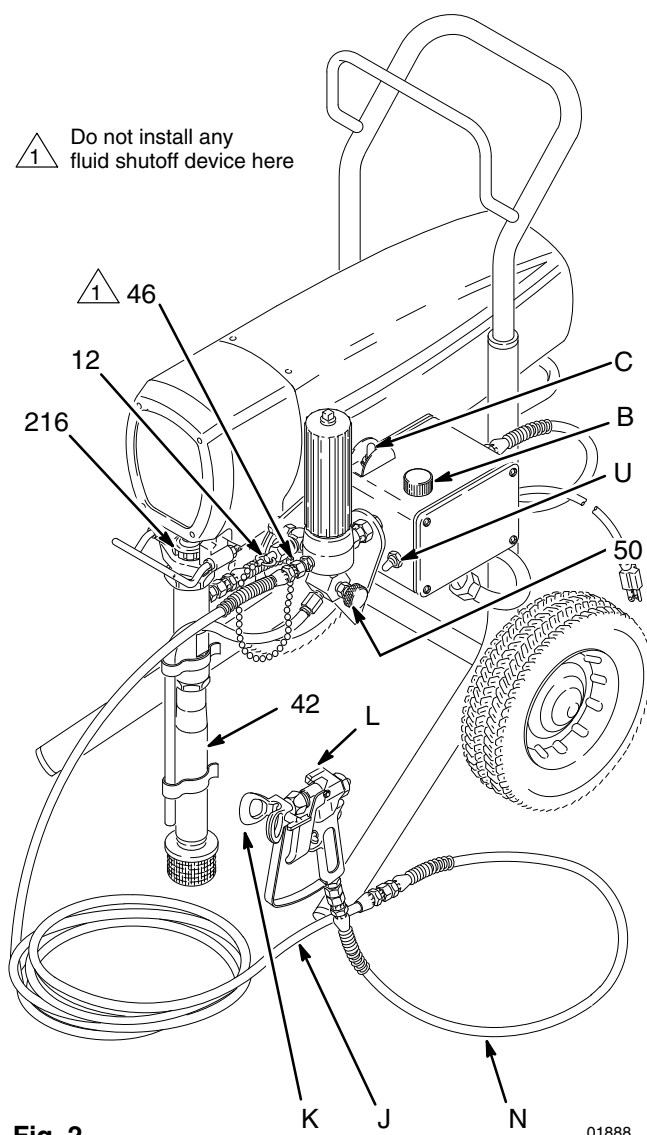

Fig. 2

01888

# Operation

## ⚠ WARNING



### INJECTION HAZARD

To reduce the risk of serious injury, whenever you are instructed to relieve pressure, follow the **Pressure Relief Procedure** on page 10.

## Startup (Fig. 2)

Always use this procedure to help ensure the sprayer is ready to operate and that you start it safely.

1. **For a first time startup**, flush the sprayer. See page 9.
2. **Close the pressure drain valve (50).**
3. **Don't install the spray tip and tip guard until the pump is primed!**
4. **Put the suction tube (42) into the paint container.**
5. **Lower the pressure setting** by turning the pressure adjusting knob (B) fully counterclockwise.
6. **Disengage the gun safety latch.** See Fig 3.

1 Gun safety latch shown engaged

2 Gun safety latch shown disengaged

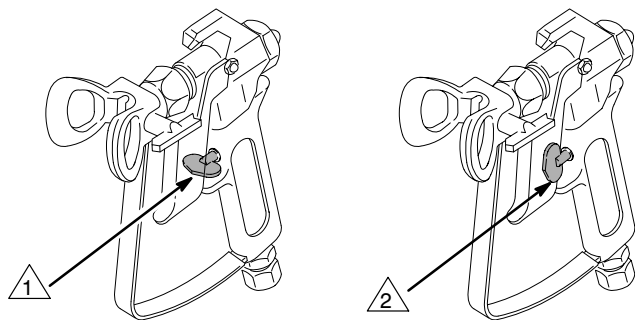

Fig. 3

0137

## ⚠ CAUTION

Do not run the sprayer dry for more than 30 seconds to avoid damaging the pump packings.

## 7. To prime the pump:

- a. Open the drain valve.
- b. Turn the ON/OFF (C) switch to ON.
- c. Slowly increase the pressure setting until the sprayer starts.
- d. When fluid is flowing from the valve, turn down the pressure and close the valve.
- e. Hold a metal part of the gun firmly against a grounded metal waste container. See Fig. 4.

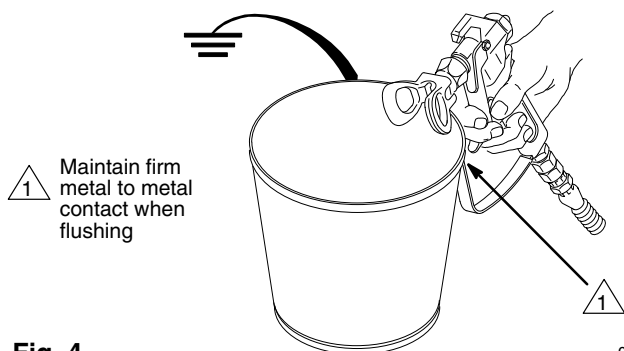

Fig. 4

0143

- f. Trigger the gun and slowly increase the pressure setting until the sprayer starts. Keep the gun triggered until all air is forced out of the system and the paint flows freely from the gun.
  - g. Release the trigger and engage the gun safety latch. See Fig 3.
8. **Check all fluid connections for leaks.** If any leaks are found, relieve pressure before tightening the connections.

# Operation

9. **Install the spray tip and tip guard.** Engage the gun safety latch. Install the spray tip. If you are using the RAC IV tip guard, refer to manual 307–848 for installation instructions.
10. **Adjust the pressure.**
  - a. Turn the pressure adjusting knob clockwise just until spray from the gun is completely atomized. To avoid excessive overspray and fogging, and to decrease tip wear and extend the life of the sprayer, always use the lowest possible pressure needed to get the desired results.
  - b. If more coverage is needed, use a larger tip rather than increasing the pressure.
  - c. Test the spray pattern. To adjust the direction of the spray pattern: engage the gun safety latch, loosen the retaining nut, position the tip guard horizontally for a horizontal pattern or vertically for a vertical pattern and tighten the retaining nut.

3. Return the switch tip to the original position, disengage the gun safety latch, and resume spraying.
4. If the tip is still clogged, engage the gun safety latch, shut off and unplug the sprayer, and open the pressure drain valve to relieve pressure. Clean the spray tip as shown in manual 307–848, supplied with the RAC IV.

## Shutdown and Care

1. **Check the packing nut/wet-cup (216) daily.** Relieve the pressure. Keep the packing nut/wet-cup 1/3 full with TSL at all times to help prevent fluid buildup on the piston rod and premature wear of packings. Tighten the packing nut just enough to stop leakage. Overtightening may cause binding and excessive packing wear. Use a screwdriver and light hammer to adjust the nut. See Fig. 6.
2. **Clean the fluid filter (48) often** and whenever the sprayer is stored. First relieve pressure. See manual 307–273 for the cleaning procedure.
3. **Fill the connecting rod cavity (A) with motor oil** every 100 hours of operation. Relieve pressure first. See Fig. 6.

## Cleaning a Clogged Tip

**⚠ WARNING**

**INJECTION HAZARD**

To reduce the risk of serious injury, whenever you are instructed to relieve pressure, follow the **Pressure Relief Procedure** on page 10.

1. If the spray tip clogs, release the gun trigger, engage the gun safety latch, relieve pressure, and rotate the RAC IV switch tip 180°. See Fig. 5.
2. Disengage the gun safety latch and trigger the gun into a waste container. Engage the gun safety latch again.

1. Switch tip shown in spraying position
2. Gun safety latch shown engaged

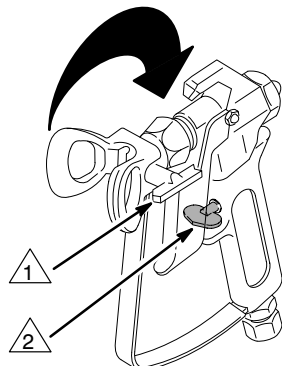

Fig. 5 0137

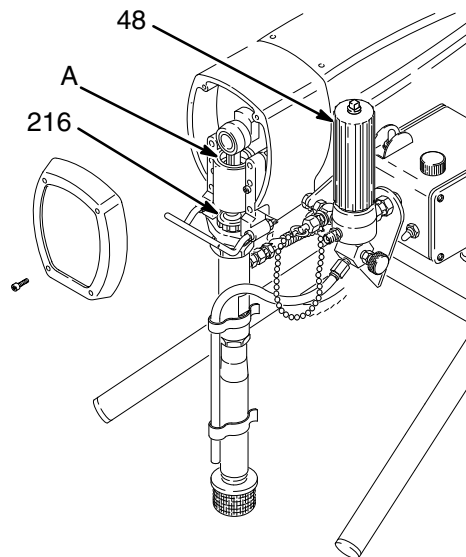

Fig. 6 01892

4. **For very short shutoff periods,** leave the suction tube in the paint, relieve pressure, and clean the spray tip.
5. **Coil the hose and hang it on the hose rack** when storing it, even for overnight, to help protect the hose from kinking, abrasion, coupling damage, etc.



# Flushing

## When to Flush

1. **New Sprayer.** The sprayer was factory tested in lightweight oil which was left in to protect pump parts.

*Before using water–base paint, flush with mineral spirits, then warm, soapy water, and then clean water.*

*Before using oil–base paint, flush with mineral spirits.*

2. **Changing Colors.** Flush with a compatible solvent.
3. **Changing water–base to oil–base paint.** Flush with warm, soapy water, then mineral spirits.
4. **Changing from oil–base to water–base paint.** Flush with mineral spirits, then warm, soapy water, and then clean water.

5. **Storage.** Flush as indicated below, shut off the sprayer, open the pressure drain valve to relieve pressure and leave it open.

*Water–base paint:* flush with water, then mineral spirits. Leave the system filled with mineral spirits.

*Oil–base paint:* flush with mineral spirits.

## ⚠ CAUTION

Never allow water to freeze in the pressure control. Doing so prevents the sprayer from being started and causes serious damage to the pressure control. Push the water out with mineral spirits.

6. **Startup after storage.** Before using water–base paint, flush out the mineral spirits with soapy water and then clean water. When using oil–base paint, flush out the mineral spirits with the paint to be sprayed.

## How to Flush

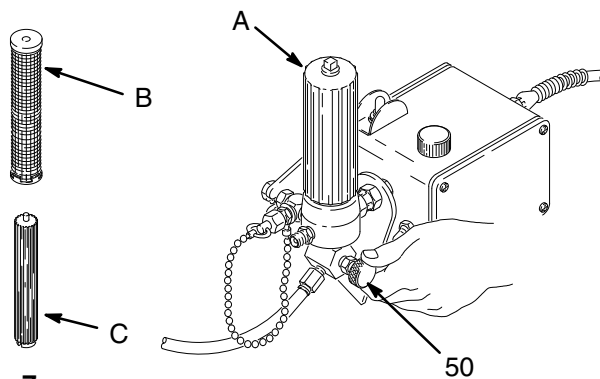

Fig. 7

1. Relieve pressure.
2. Remove the filter bowl (A), support (C) and screen (B); see manual 307–273. Install the bowl and support. Clean the screen separately and install after flushing.. See Fig 7.
3. Close the pressure drain valve.
4. Pour one–half gallon of compatible solvent into a grounded metal pail. Put the suction tube in the pail.
5. Remove the spray tip from the gun, if it is installed.
6. Turn the pressure adjusting knob all the way counterclockwise to lower the pressure setting.

7. Open the drain valve. Turn on the sprayer and increase the pressure until until the sprayer starts. When fluid comes from the valve, close it. Hold a metal part of the gun firmly against a metal waste container. Trigger the gun until all air is forced out of the system and the solvent flows freely from the gun. Release the trigger and engage the gun safety latch.

## ⚠ WARNING



### FIRE AND EXPLOSION HAZARD

To reduce static sparking and splashing, always remove the spray tip from the gun, and hold a metal part of the gun firmly to the side of a grounded metal pail when flushing.

8. Remove the suction tube from the pail. Disengage the gun safety latch and trigger the gun to force solvent from the hose. Do not run the pump dry for more than 30 seconds to avoid damaging the pump packings! Relieve pressure.
9. Leave the pressure drain valve open until you are ready to use the sprayer again. If the screen was removed, unscrew the filter bowl and reinstall the clean screen. Reinstall the bowl, hand tight only.
10. If you flushed with mineral spirits and are going to use a water–base paint, flush with soapy water and then clean water. Relieve pressure.

# Troubleshooting

## Pressure Relief Procedure

To reduce the risk of serious bodily injury, including fluid injection, injury from splashing fluid or solvent in the eyes or on the skin, moving parts or electric shock, always follow this procedure whenever you shut off the sprayer, when checking or servicing any part of the spray system, when installing, cleaning or changing spray tips, and whenever you stop spraying.

1. Engage the gun safety latch.
2. Turn the ON/OFF switch to OFF.
3. Unplug the power supply cord.

4. Disengage the gun safety latch. Hold a metal part of the gun firmly to a grounded metal pail. Trigger the gun to relieve pressure.
5. Engage the gun safety latch.
6. Open the pressure drain valve. Leave the pressure drain valve open until you are ready to spray again.

*If you suspect that the spray tip or hose is completely clogged, or that pressure has not been fully relieved after following the steps above, VERY SLOWLY loosen the tip guard retaining nut or hose end coupling to relieve pressure gradually, then loosen completely. Now clear the tip or hose obstruction.*

Check everything in the troubleshooting table before disassembling the sprayer.

| TYPE OF PROBLEM                | WHAT TO CHECK<br><i>If check is OK, go to next check</i>  | WHAT TO DO<br><i>When check is not OK refer to this column</i>  |
|--------------------------------|---|---|
| Building circuit breaker opens | Check all electrical wiring for damaged insulation.   | Replace any damaged wiring.   |
|                                | Check for other electrical appliances on circuit.   | Shutdown other electrical appliances on circuit.  |
|                                | Check position of 15–20 (Lo-High) amp switch.   | Put switch in 15 amp (LO) position.   |
| Sprayer circuit breaker opens  | Check for locked motor rotor. Unplug cord and try to turn fan blades with a screwdriver.                              | Repair gear train or pump, if damaged. Thaw the sprayer, if frozen; See NOTE 1. Replace the pressure control, if damaged. |
|                                | Check for shorted motor. Use ohmmeter to check for shorts between motor leads or between motor leads and motor frame. | Inspect for damage to motor brush leads. Replace motor, if necessary.   |
|                                | Check electrical supply with voltmeter. Meter should read 105–125 VAC.  | Connect to outlet of correct voltage.   |
| Sprayer will not run           | Check pressure control knob setting. Motor will not run if it is at minimum setting (fully counterclockwise).         | Slowly increase pressure setting to see if motor starts.  |
|                                | Check for a clogged spray tip. Refer to separate gun or tip instruction manual.                                       | Relieve pressure. Refer to separate gun or tip instruction manual for tip cleaning.                                       |
|                                | Check extension cord for visible damage. Use a volt meter or test lamp at extension cord outlet to check.             | Replace extension cord.   |
|                                | Check sprayer power supply cord for visible damage such as broken insulation or wires.                                | Replace power supply cord.  |
|                                | Check electrical supply with volt meter. Meter should read 105–125 VAC.   | Reset building circuit breaker; replace building fuse. Try another outlet.  |
|                                | Check for motor damage. Remove drive housing assembly. See page 21. Try to rotate fan by hand.                        | Replace motor (1) if fan won't turn.  |
| Poor spray pattern             | Check for worn spray tip.   | Relieve pressure and then replace the tip. See the separate gun or tip manual.  |

# Troubleshooting

| TYPE OF PROBLEM   | WHAT TO CHECK<br><i>If check is OK, go to next check</i>  | WHAT TO DO<br><i>When check is not OK refer to this column</i>   |
|---|---|--|
| Motor runs and pump strokes, but output is low or there is no output. | Check extension cord size and length.   | Replace cord with a larger size, grounding type extension cord.  |
|   | Check paint supply.   | Refill and reprime pump.   |
|   | Check for clogged intake strainer.  | Remove and clean strainer and reinstall.   |
|   | Check for loose suction tube or loose fittings.   | Tighten; use thread sealant or sealing tape on threads, if necessary.  |
|   | Check for worn spray tip.   | Follow <b>Pressure Relief Procedure Warning</b> , then replace tip. See your separate gun or tip manual.   |
|   | Check motor brushes; check for loose leads and terminals, minimum 1/2" brush length, broken or misaligned springs, or brushes binding in holders. See page 12.  | Replace parts as needed. See page 12.  |
|   | Check motor armature for shorts by using an armature tester (growler).  | Replace motor. See page 19.  |
|   | Check to see if pump continues to stroke when gun trigger is released. With pump on and primed, trigger gun momentarily, then release and engage safety latch. Relieve pressure, turn off and unplug sprayer. | Service pump. See page 13.   |
|   | Check to see if intake valve ball and piston ball are seating properly.   | Remove intake valve and clean. Check balls and seats for nicks; replace if necessary. See page 14. Strain paint before using to remove particles that could clog the pump. |
|   | Check for leaking around throat packing nut which may indicate worn or damaged packings.  | Replace packings. See page 13. Also check piston valve seat for hardened paint or nicks and replace if necessary. Tighten the packing nut/wetcup.                          |
| Motor runs but pump does not stroke.                                  | Check displacement pump connecting rod pin (20). See page 17.   | Replace pin, if missing. Be sure retainer spring (35) is fully in groove all around connecting rod. See Fig. 38, page 17.  |
|   | Check for frozen or hardened paint in the pump (39).  | Thaw. See NOTE 1. Plug in sprayer and turn on. Slowly increase pressure setting to see if motor starts.  |
|   | Be sure crank in drive housing rotates; plug in sprayer and turn on briefly to check. Turn off and unplug sprayer.  | Check drive housing assembly for damage and replace if necessary. See page 21.   |
| Motor is hot and runs intermittently.                                 | Determine if sprayer was operated at high pressure with small tips, which causes low motor RPM and excessive heat build up.   | Decrease pressure setting or increase tip size.  |
|   | Be sure ambient temperature where sprayer is located is no more than 90°F and sprayer is not located in direct sun.   | Move sprayer to shaded, cooler area, if possible.  |
|   | Determine if sprayer was turned on, pressurized, but not operating for long periods of time.  | Turn off sprayer whenever you stop spraying for a while and relieve fluid pressure.  |

**NOTE 1:** Thaw the sprayer if water or water-based paint has frozen in it, by placing it in a warm area. Do not try to start the sprayer until it has thawed completely. If paint hardened (dried) in the sprayer, replace the pump packings. See page 15.

# Motor Brush

**NOTE:** Replace the brushes when they have worn to about 0.4 in (10 mm). Always check both brushes and replace them together. A Brush Repair Kit, p/n 220–853, and the spring clip, p/n 110–816, are available. Order separately.

**NOTE:** Replacement brushes may last only half as long as the original ones. To maximize brush life, break in new brushes by operating the sprayer for at least one hour with no load (remove the pump connecting rod pin).

9. Reinstall the remaining parts.

**⚠ WARNING**



**INJECTION HAZARD**

To reduce the risk of serious injury, whenever you are instructed to relieve pressure, follow the **Pressure Relief Procedure** on page 10.

1. Remove the motor cover (14) and both inspection covers (A). See Fig 8.
2. Push in the spring clip (D) to unhook it, and then pull it out. See Fig 9.
3. Loosen the terminal screw (F). Pull the brush lead (G) away, leaving the motor lead in place. Remove the brush (C) and spring (B). See Fig 10.
4. Inspect the commutator for excessive pitting, burning or gouging. A black color on the commutator is normal. Have the commutator resurfaced by a qualified motor repair shop if the brushes seem to wear too fast.
5. Install the new brush (C) so its lead is in the long slot (K) of the holder (H). Slide the terminal (E) under the terminal screw (F) washer. Make sure the motor lead terminal (G) is still connected at the screw. Tighten the screw. See Fig 11.
6. Place the spring (B) on the brush (C) as shown in Fig 11.
7. Push in and hook the spring clip (D). See Fig 11.
8. Repeat for the other side.

**⚠ CAUTION**

Do not run the sprayer dry for more than 30 seconds while checking the brushes to avoid damaging the displacement pump.

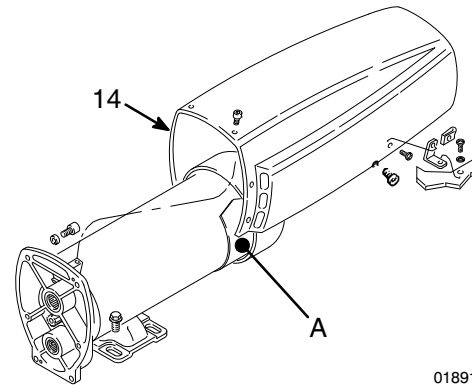

Fig. 8

01891

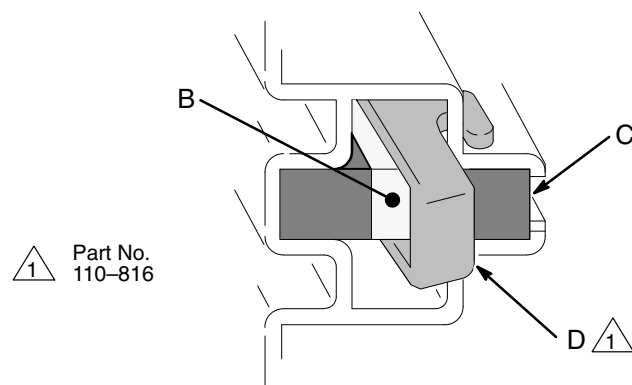

Fig. 9

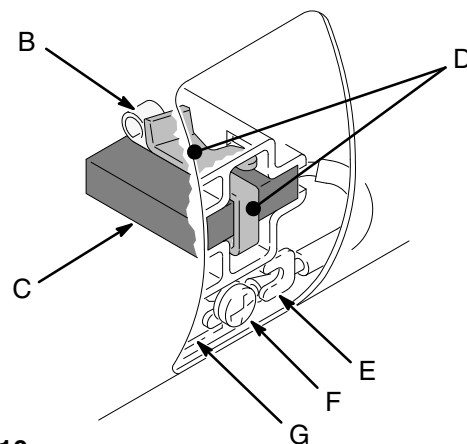

Fig. 10

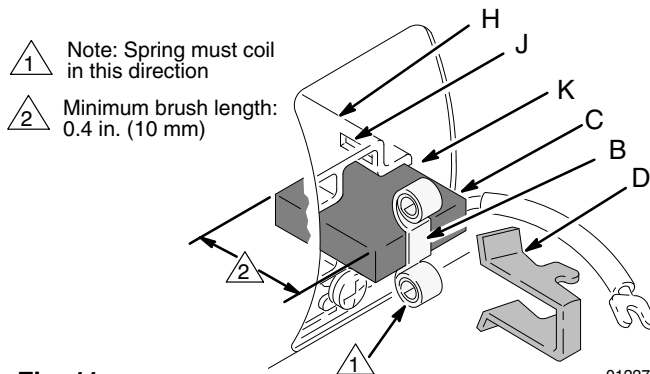



Fig. 11

01227

# Displacement Pump

## Removing the Pump

|   |   |
|---|---|
| <b>⚠ WARNING</b>  |   |
|  | <b>INJECTION HAZARD</b><br>To reduce the risk of serious injury, whenever you are instructed to relieve pressure, follow the <b>Pressure Relief Procedure</b> on page 10. |

1. Flush the pump, if possible, and relieve pressure again. Stop the pump with the piston rod in its lowest position, if possible.
2. Remove the hose (47), clips and drain tube (101). Remove the suction tube (42); hold the wrench on the pump intake valve (223) to keep the pump from loosening. See Fig. 12.
3. Push the retaining spring (35) up. See Fig. 13.
4. Push out the pin (20). See Fig. 14.
5. Loosen the locknut (38) and unscrew the pump from the bearing housing (27). See Fig. 15.

## Tools Needed for Pump Repair

Repair Kit, P/N 220-877

Sleeve Removal Tool, P/N 220-991

Heavy duty vise

1-1/16" open end wrench for Pump 220-872

2-1/4" adjustable, open-end wrench

Plastic mallet

Small screwdriver

Throat Seal Liquid

Thread Sealant

**NOTE:** Soak leather packings in oil before installing.

## Cleaning and Inspecting Parts

Clean and inspect the parts. Pay particular attention to the ball seat in the intake valve, which should have no nicks or wear, and to the inside of the sleeve and the outside of the piston rod, which should not be worn or scratched. Replace worn or damaged parts.

Remove and clean the sleeve when you are repacking the pump. A special sleeve removal tool is available. See the chart, above, for the tool number for your pump.

|  |   |
|--|---|
| <b>⚠ WARNING</b>   |   |
|  | <b>INJECTION HAZARD</b><br>Always use the special sleeve removal tool to remove the sleeve. Other removal methods could cause the pump to rupture, resulting in serious bodily injury. If the sleeve cannot be removed easily using the tool, return the sleeve and cylinder to your Graco distributor for removal. |

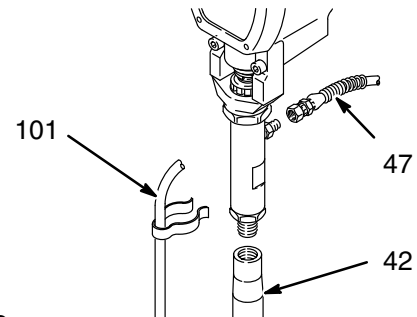

Fig. 12

02553

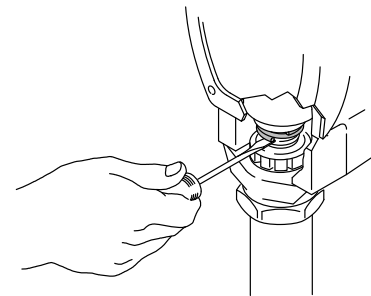

Fig. 13

02554

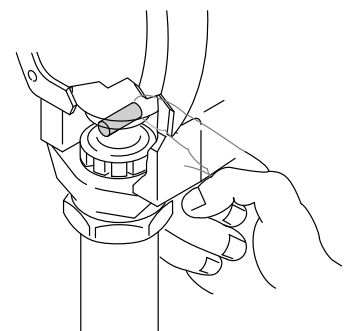

Fig. 14

02555

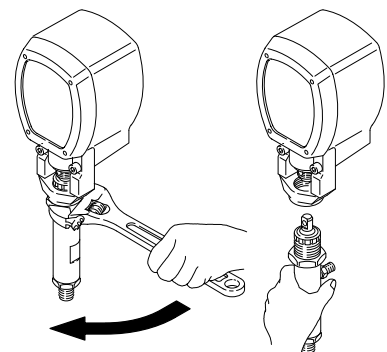

Fig. 15

02556

# Displacement Pump

## Disassembly

**NOTE:** Parts included in the Packing Repair Kit, P/N 220–877, are marked with an asterisk (\*) in the text and drawings. Use all the new parts in the kit.

1. Loosen the packing nut (216) and remove the plug (205). Unscrew the cylinder from the intake valve. See Fig. 16.
2. Disassemble the intake valve. Use a pick to remove the old gasket (202). Clean and inspect the parts. See Fig. 17.
3. Reassemble the intake valve using a new gasket (\*202\*), ball (\*204\*) and pin (\*221\*). See Fig. 17.
4. Tap the piston rod (224) out of the cylinder. See Fig. 18.
5. Screw the sleeve removal tool's large nut (A) into the top of the cylinder. Screw down the rod to push the sleeve out. See Fig. 19. Remove the tool. Clean and inspect the parts.
6. Clamp the piston rod (224) in a vise. Loosen the retaining nut (211). Unscrew the piston valve (222). See Fig. 20.
7. Disassemble the piston and discard the packings and glands. See Fig. 21.
8. Remove and discard the throat packings and glands from pump cylinder. See Fig. 22.

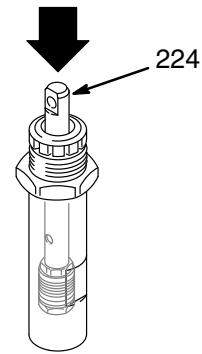

Fig. 18

02561

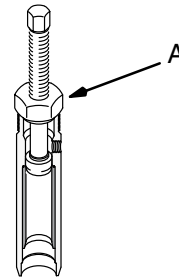

Fig. 19

02562

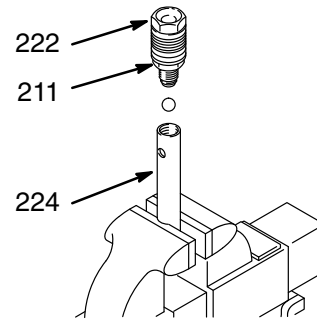

Fig. 20

02563

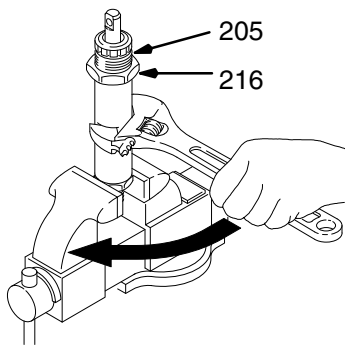

Fig. 16

02558

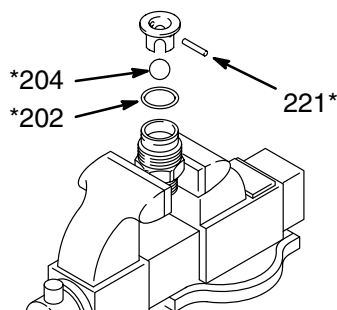

Fig. 17

02559

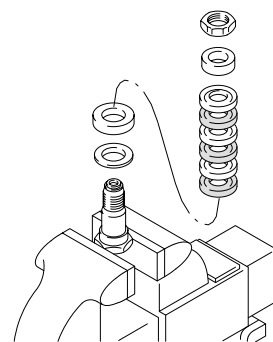

Fig. 21

02564

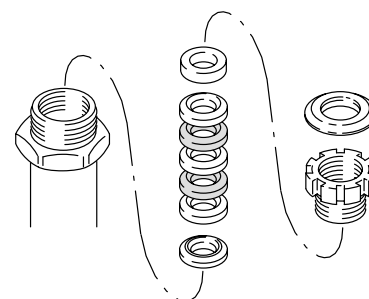

Fig. 22

02565

# Displacement Pump

## Pump Reassembly

1. Clean the piston valve threads. One at a time, stack the backup washer (203\*), seal (215\*) (with lips facing down), and female gland (214\*) on the piston. Alternately stack the polyethylene (212\*) and leather (206\*) packings (lips facing up) on the piston. Then install the male gland (210\*). See Fig. 23.
2. Place the flats of the piston valve in a vise. Tighten the packing retaining nut against the piston valve to 4 in-lb (0.35 N.m). See Fig. 24.

**Note the alignment** of the piston to the packing retainer nut. Maintain this alignment through Steps 4 and 5.

3. Apply one drop of Loctite to the threads. Place the ball (225\*) on the piston valve. See Fig. 25.
4. While maintaining the alignment, thread the piston valve assembly into the piston rod just until the piston valve nut contacts the rod. See Fig. 26.
5. Place the flats of the rod in a vise. Carefully tighten the piston valve nut (211) against the piston rod to 19 ft-lb (27 N.m). Use two wrenches to maintain the alignment. See Fig. 27.
6. Place the male gland (208\*) in the cylinder. Alternately stack the polyethylene (213\*) and leather packings (207\*) (lips facing down). Then place the female gland (209\*) in the top of the cylinder. Seat the packings. See Fig. 28.

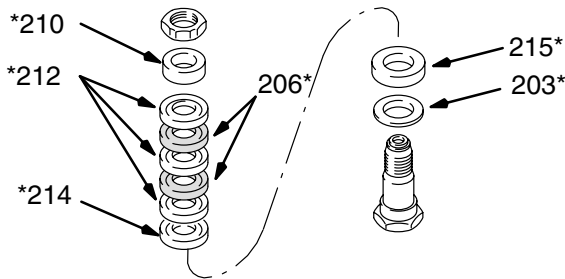

Fig. 23 02566

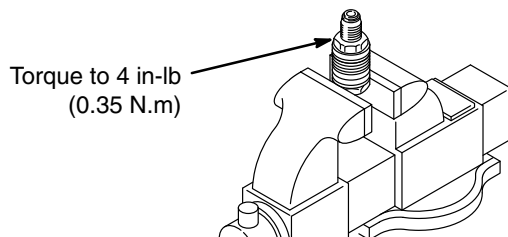

Fig. 24 02567

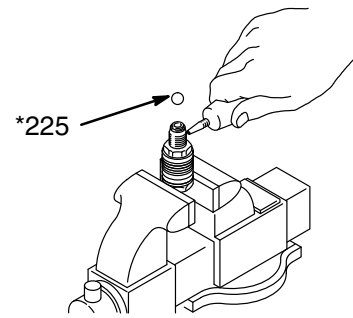

Fig. 25 02568

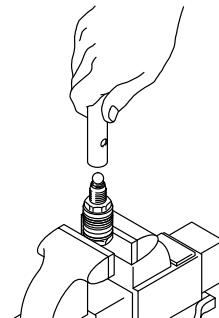

Fig. 26 02569

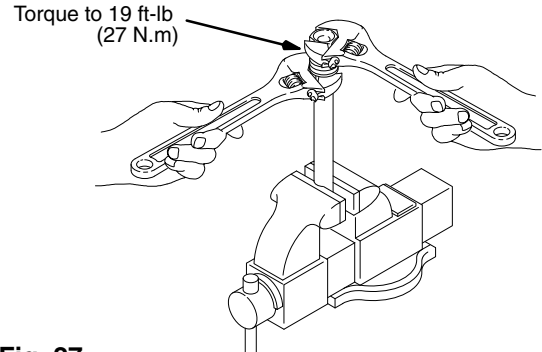

Fig. 27 02570

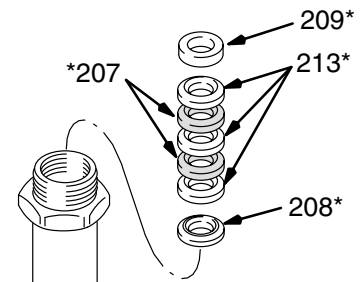

Fig. 28 02571

# Displacement Pump

7. Loosely install the packing nut (216) and plug (205). See Fig. 29.
8. Place a o-ring (217\*) in the cylinder. Slide the sleeve in to the cylinder to seat the o-ring. See Fig. 30. Remove the sleeve.
9. Grease the piston packings and the top edge of the sleeve. See Fig. 31.
10. Carefully slide the piston assembly into the top of the sleeve. See Fig. 32.
11. Slide the sleeve/piston rod assembly into the bottom of the cylinder. See Fig. 33.
12. Grease the intake valve o-ring with non-silicon grease. Screw the pump cylinder into the intake valve. Torque to 70 ft-lb (95 N.m). See Fig. 34.
13. Tighten the packing nut (216) hand tight. Screw the cylinder locknut (A) down to the bottom of the external cylinder threads. See Fig. 35.

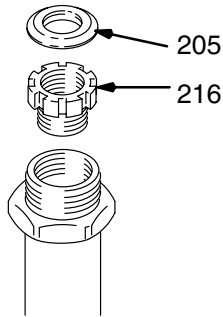

Fig. 29 02572

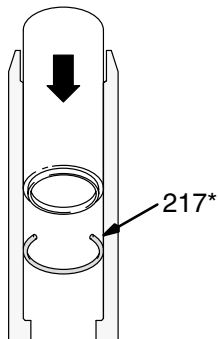

Fig. 30 02573

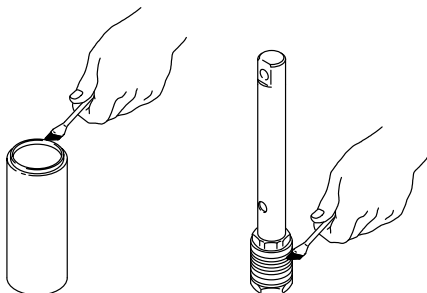

Fig. 31 02574

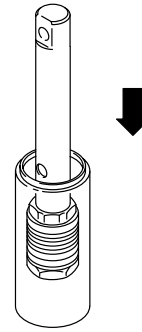

Fig. 32 02575

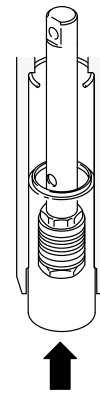

Fig. 33 02576

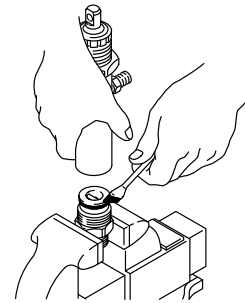

Fig. 34 02577

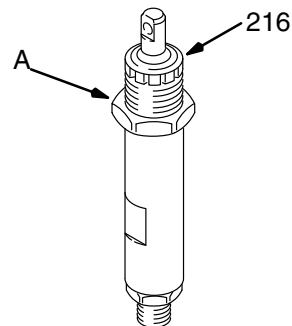

Fig. 35 02578



# Displacement Pump

## Installing the Pump

1. Screw the displacement pump into the bearing housing (27) until the pin holes align. See Fig. 36.
2. Install the pin (221\*). See Fig. 37.
3. Continue to screw the pump into the bearing housing until the top threads of the pump cylinder are flush with the face of the bearing housing and the outlet nipple is straight back. Push the retaining spring (35) into the groove all the way around the connecting rod to prevent it from working loose due to vibration. See Fig. 38.

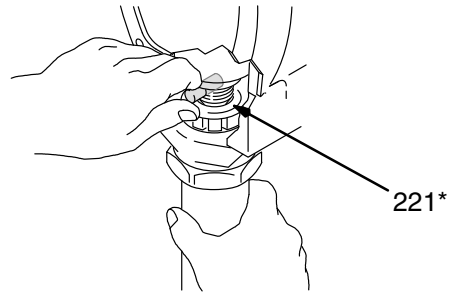



Fig. 37

02580

|   |   |
|---|---|
| <b>⚠ WARNING</b>  |   |
|  | <b>MOVING PARTS HAZARD</b><br>If the pin works loose, it or other parts could break off due to the force of the pumping action. These parts could be projected through the air and result in serious bodily injury or property damage, including damage to the pump, connecting rod or bearing housing. |

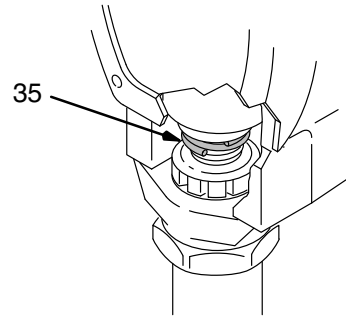

Fig. 38

02581

4. Tighten the locknut (38) to 70 ft-lb (97 N.m). See Fig. 39.

|   |  |
|---|--|
| <b>⚠ CAUTION</b>  |  |
| If the locknut (38) loosens during operation, the threads of the bearing housing (29) will be damaged. Be sure to tighten the locknut firmly. |  |

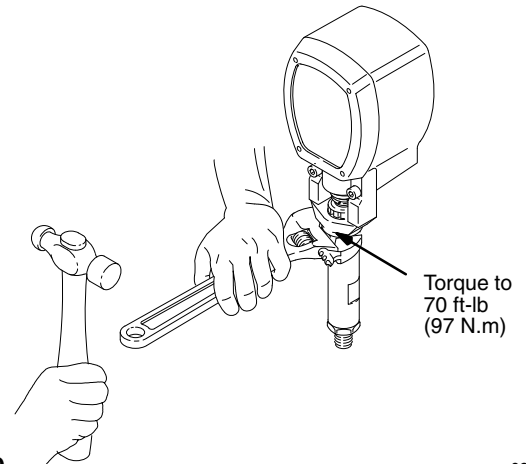

Fig. 39

02582

5. Tighten the packing nut/ wet-cup just enough to stop leakage, but no tighter. Fill the wet-cup/packing nut 1/3 full with Graco TSL. See Fig. 40.

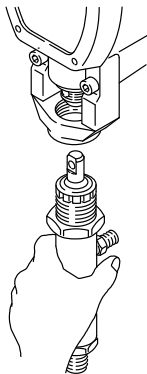

Fig. 36

02579

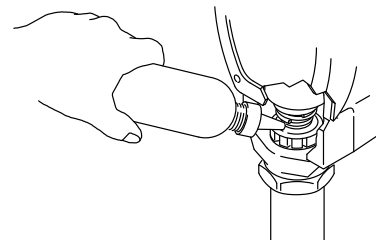

Fig. 40

02583

# Pressure Control

## ! WARNING



### INJECTION HAZARD

To reduce the risk of serious injury, whenever you are instructed to relieve pressure, follow the **Pressure Relief Procedure** on page 10.

**NOTE:** Refer to Fig. 41 except where noted.

1. Disconnect the hose (47).
2. Disconnect the drain tube (101) from the drain valve.
3. Loosen the outside filter bracket nut (28). Unscrew the swivel fitting (8) and remove the filter.
4. Remove the pressure control cover (36). Disconnect the four motor leads. See Fig. 42.
5. Unscrew the connector (54). Pull the wires out of the pressure control.
6. Remove the pressure control mounting screws (37). Remove the pressure control. Install the connector (54) on the new pressure control.
7. Install the new pressure control. Place the seal (103) around the motor leads and push the seal into the connector (54). See Fig. 42.

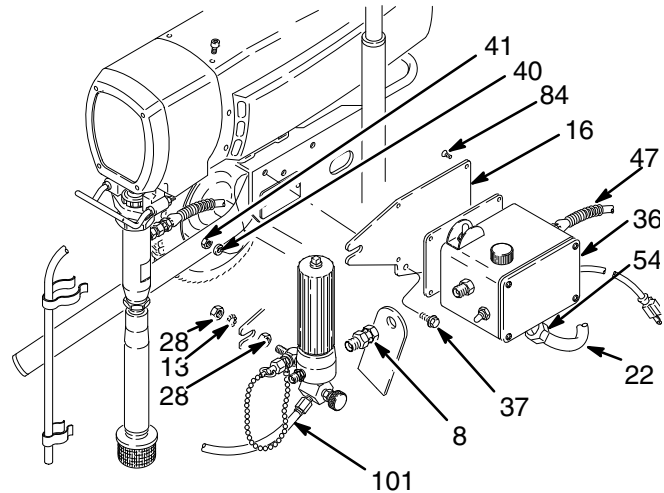

Fig. 41

01894

# Power Supply Cord

## ! WARNING



### INJECTION HAZARD

To reduce the risk of serious injury, whenever you are instructed to relieve pressure, follow the **Pressure Relief Procedure** on page 10.

**NOTE:** Refer to Fig. 41 except where noted.

1. **Relieve pressure.**
2. Remove the back pressure control plate (16).
3. Remove the pressure control cover. Disconnect the power supply cord leads. See Fig. 42.
4. Loosen the strain relief bushing (B). Remove the power supply cord (23).
5. Install the new cord.

### BACK VIEW OF PRESSURE CONTROL

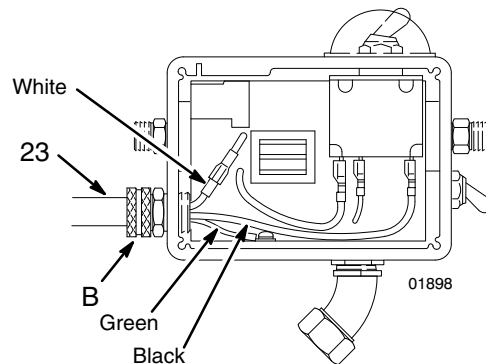

### FRONT VIEW OF PRESSURE CONTROL

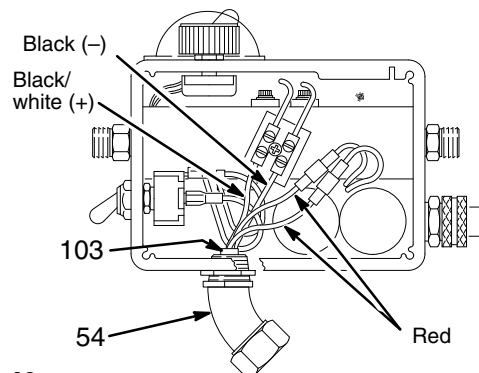

Fig. 42

01897

# Motor

**⚠ WARNING**

**INJECTION HAZARD**

To reduce the risk of serious injury, whenever you are instructed to relieve pressure, follow the **Pressure Relief Procedure** on page 10.

**⚠ CAUTION**

To avoid damage to the drive housing:

- Do not drop the gear cluster (9), which may stay engaged in the motor bell or in the drive housing.
- Do not lose the thrust balls (10) or drop them between gears. The balls usually stay in the shaft recesses, but could be dislodged. If the balls are not in place, the bearings will wear prematurely.

- Remove the motor shield (14). Remove the front cover (31). Disconnect the hose (47).
- Remove the pressure control cover (36). Disconnect the four motor leads.
- Unscrew the connector (54) from the pressure control. Pull the wires through the connector.
- Unscrew the connector (54) from the motor and remove the conduit (22).
- Remove the screws (51) from the recess of the drive housing.
- Remove the screws (21 and 30) from the motor end bell (F).
- Use a plastic mallet to tap the displacement pump (39) from the rear to loosen the drive housing (18) from the motor end bell (F). Pull off the drive housing.
- Remove the screws (37) holding the motor to the frame. Lift off the motor.
- Mount the new motor on the frame.
- Slide a connector (54) over the conduit (22) of the new motor and screw two or three threads of it into the motor. Tighten the locknut (44) up to the motor.
- Liberally grease the gear cluster (9) and pinion gear (G) and pack all bearings in the motor end bell. Be sure the thrust balls (10) are in place. (One ball is included with a replacement drive housing.)
- Place the bronze-colored washer (18b) and THEN the silver-colored washer (18a) on the shaft protruding from the big gear in the drive housing (18).
- Align the gears and push the drive housing (18) straight onto the motor bell (F) and locating pins.
- Continue to reassemble the sprayer.

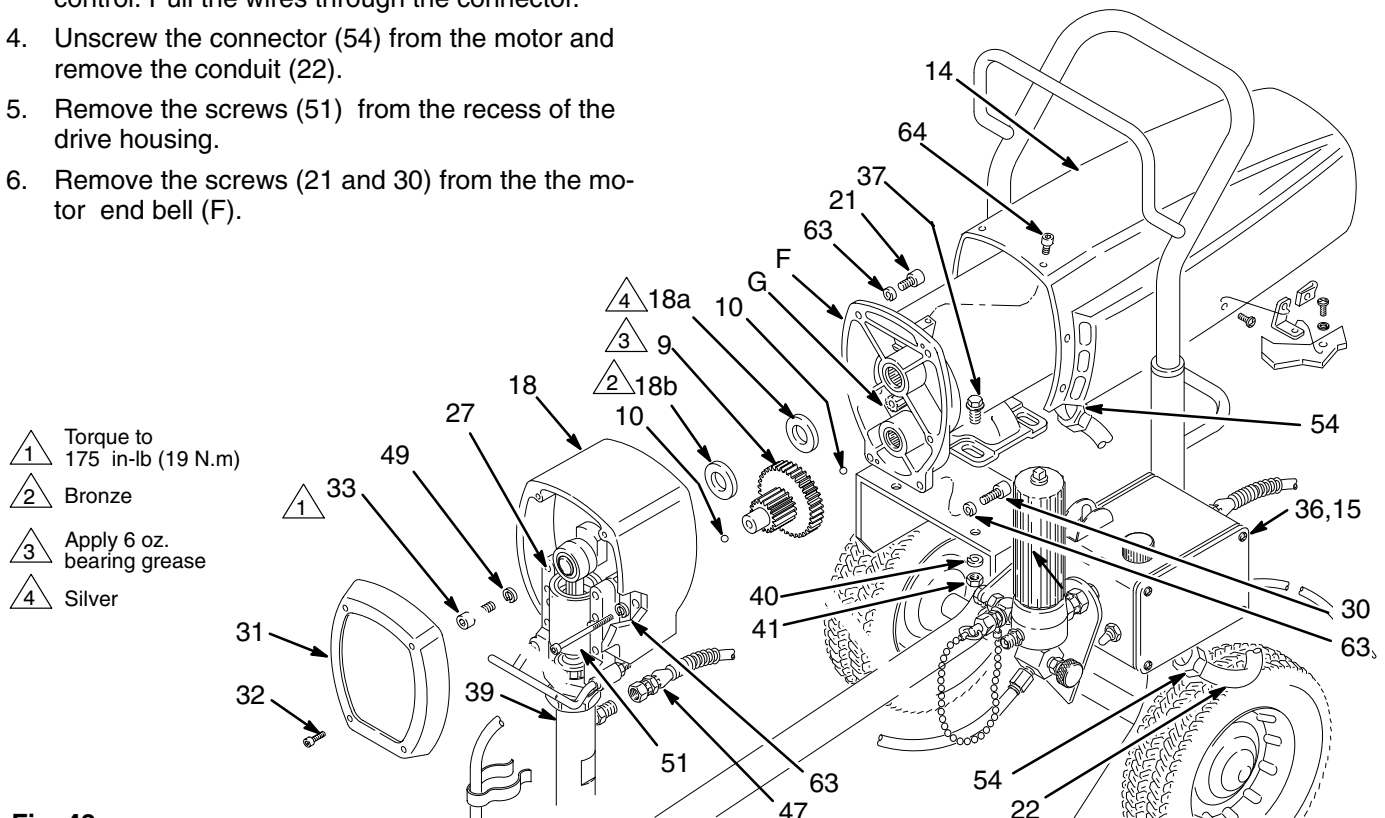

Fig. 43

# Bearing Housing & Connecting Rod

## ⚠ WARNING



### INJECTION HAZARD

To reduce the risk of serious injury, whenever you are instructed to relieve pressure, follow the **Pressure Relief Procedure** on page 10.

**NOTE:** Stop the sprayer at the bottom of its stroke to get the crank (H) in its lowest position. To lower the crank manually, rotate the blades of the motor fan with a screwdriver.

1. Remove the pump. See page 13.
2. Remove the front cover (31). Remove the bearing housing screws (33).
3. Tap the lower rear of the bearing housing (27) with a plastic mallet to loosen it from the drive housing (18). Pull the bearing housing and the connecting rod (29) straight off the drive housing.
4. Remove the pail bracket assembly (L) and reinstall it on the new bearing housing.
5. Inspect the crank (H) for excessive wear and replace parts as needed.
6. Evenly lubricate the inside of the bronze bearing (K) with motor oil. Liberally pack the roller bearing (J) with bearing grease.
7. Slide the connecting rod (29) into the bearing housing (27).
8. Clean the mating surfaces of the bearing and drive housings.
9. Align the connecting rod with the crank (H) and align the locating pins in the drive housing with the holes in the bearing housing (27). Push the bearing housing onto the drive housing or tap it into place with a plastic mallet.
10. Install the bearing housing screws (33). Torque evenly to 175 in-lb (19 N.m).
11. Reinstall all parts. See page 17 to install the pump.

1. Torque to 175 in-lb (19 N.m)
2. Lubricate with motor oil
3. Liberally pack roller bearing with bearing grease

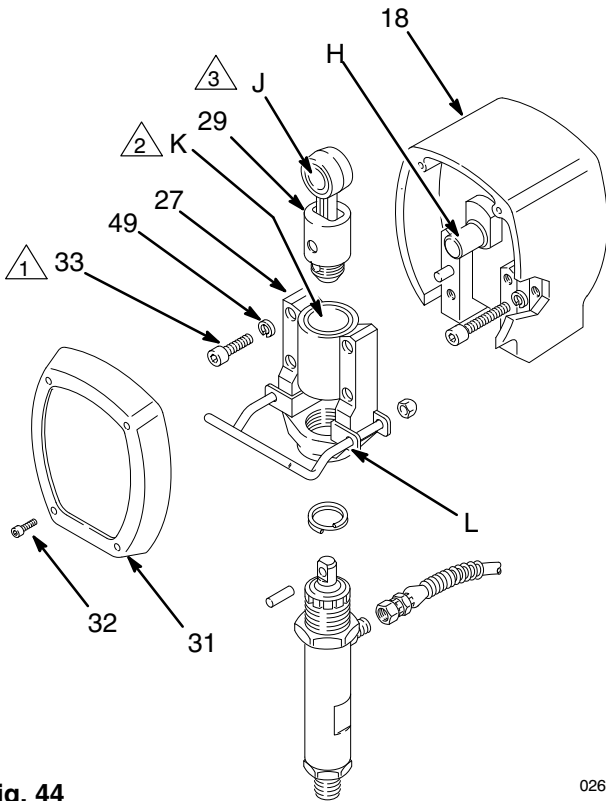

Fig. 44

02654

# Drive Housing

**⚠ WARNING**

**INJECTION HAZARD**

To reduce the risk of serious injury, whenever you are instructed to relieve pressure, follow the **Pressure Relief Procedure** on page 10.



**NOTE:** Stop the sprayer at the bottom of its stroke to get the crank (H) in its lowest position. To lower it manually, carefully rotate the blades of the fan with a screwdriver.

1. Remove the front cover (31). Remove the motor shield (14).
2. Disconnect the pump outlet hose (47).
3. Remove the screws (33) from the bearing housing.
4. Lightly tap the lower rear of the bearing housing (27) with a plastic mallet to loosen it from the drive housing (18). Pull the bearing housing and connecting rod assembly straight off the drive housing.
5. Remove the screws (51) from the recess of the drive housing.
6. Remove the screws (30 and 21) from the motor end bell (F).

7. Tap the drive housing (18) with a plastic mallet to loosen it from the motor end bell, then pull it straight off.

**⚠ CAUTION**

To avoid damage to the drive housing:

- Do not drop the gear cluster (9), which may stay engaged in the motor bell or in the drive housing.
- Do not lose the thrust balls (10) or drop them between gears. The balls usually stay in the shaft recesses, but could be dislodged. If the balls are not in place, the bearings will wear prematurely.

8. Use approximately 6 oz. of the bearing grease supplied with the drive housing replacement kit to grease the gear cluster (9). Check to be sure the thrust balls (10) are in place.
9. Place the bronze-colored washer (18b) and THEN the silver-colored washer (18a) on the shaft protruding from the big gear in the drive housing (18).
10. Align the gears and push the new drive housing straight onto the motor bell and locating pins.
11. Continue to reassemble the sprayer. Torque the screws (33) to 175 in-lb (19 N.m).

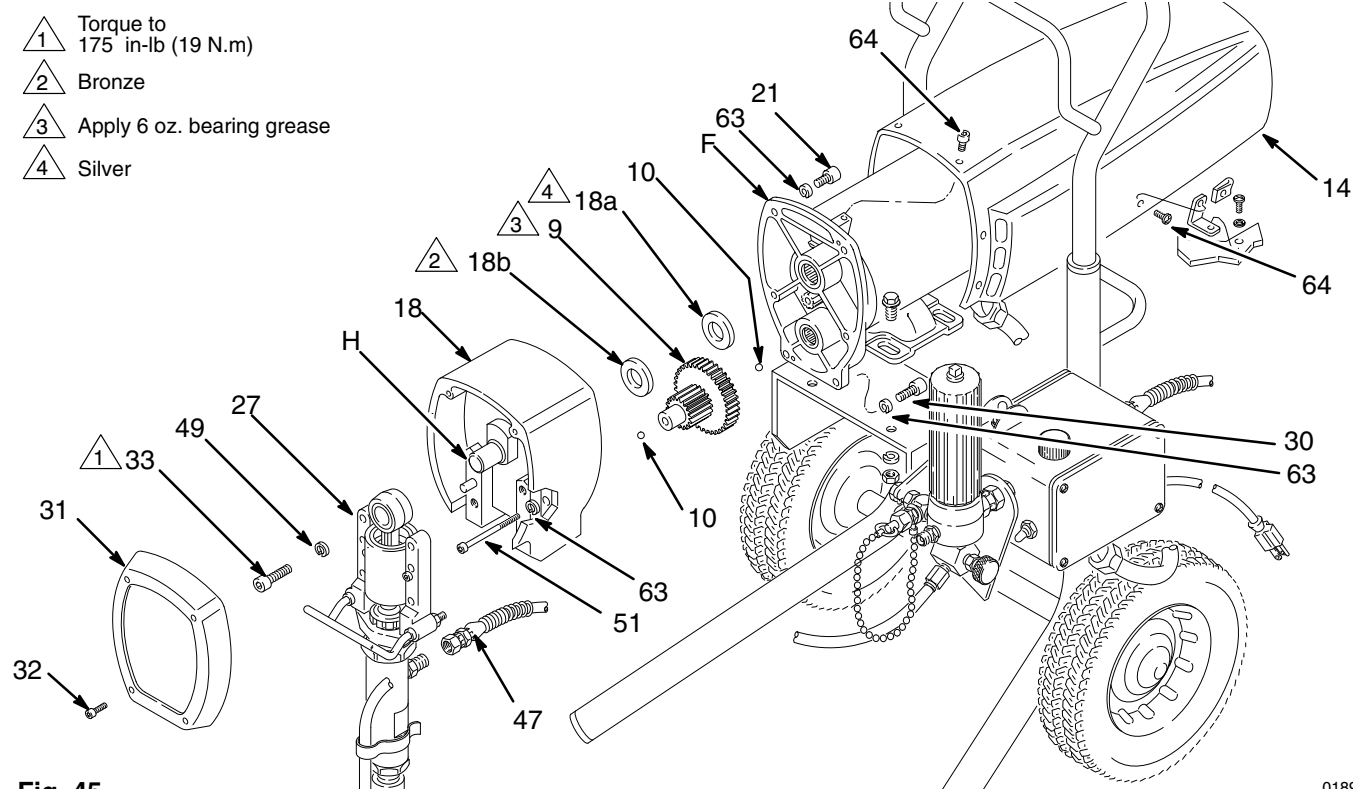

Fig. 45

01896



# Sprayer Parts List

## Model 223-773, Series A

Basic Sprayer, CSA certified, Includes items 1-109

| Ref. No. | Part No. | Description   | Qty. | Ref. No. | Part No. | Description   | Qty. |
|----------|----------|---|------|----------|----------|---|------|
|          |          |   |      | 43       |          | PRESSURE CONTROL KIT  | 1    |
|          |          |   |      |          |          | <i>includes items 13, 16, 23, 2 of 28, 34, 4 of 84</i>        |      |
|          |          |   |      |          | 223-803  | NEW KIT, for Models 231-351 & 231-352                         | 1    |
|          |          |   |      |          | 223-804  | REBUILT KIT, for Models 231-351 & 231-352                     | 1    |
|          |          |   |      |          | 224-018  | NEW KIT, for Sprayer 223-773                                  | 1    |
| 1        | 220-854  | MOTOR KIT<br><i>Includes 1 of item 92</i>                                   | 1    | 46       | 162-453  | NIPPLE, hex; 1/4 npsm x 1/4 npt, 1-3/16" long                 | 2    |
| 2        | 290-058  | LABEL, identification, motor cover  | 1    | 47       | 220-849  | HOSE, 3/8 npsm(f) x 14-1/2"                                   | 1    |
| 3        | 290-059  | LABEL, identification, motor cover  | 1    | 48       | 214-570  | FLUID FILTER<br><i>see manual 307-273 for parts</i>           |      |
| 4        | 290-057  | LABEL, identification, front cover  | 1    |          |          | <i>includes one of items 46 and 85</i>                        | 1    |
| 6        | 220-636  | CART  | 1    | 49       | 106-115  | LOCKWASHER, spring; 3/8"                                      | 4    |
| 7        | 187-147  | STRAINER  | 1    | 50       | 221-077  | PRESSURE DRAIN VALVE  | 1    |
| 8        | 155-665  | UNION, adapter; 3/8" npsm swivel x 3/8 npt(m)                               | 1    | 51       | 108-849  | CAPSCREW, sch; 1/4-20 x 3"                                    | 2    |
| 9        | 220-637  | GEAR REDUCER  | 1    | 53       | 108-691  | PLUG, tubing  | 2    |
| 10       | 100-069  | BALL, steel; 1/4" dia.  | 1    | 54       | 108-460  | CONNECTOR   | 2    |
| 11       | 104-811  | HUBCAP  | 2    | 56       | 102-556  | RIVET, blind; 1/8" dia.                                       | 2    |
| 12       | 220-285  | CAP   | 1    | 57▲      | 178-034  | TAG, WARNING  | 1    |
| 13       | 100-322  | LOCKWASHER, ext., 7/16"   | 1    | 58       | 101-242  | RING, retaining   | 2    |
| 14       | 223-153  | MOTOR SHIELD KIT  | 1    | 59       | 206-994  | THROAT SEAL LIQUID 8 oz. (0.27 liter)                         | 1    |
| 15       | 110-037  | SCREW, pnh; 10-24 type C x 1/2"   | 4    | 60       | 179-811  | WHEEL   | 2    |
| 16       | 185-539  | BRACKET, mounting   | 1    | 63       | 105-510  | LOCKWASHER, spring, 1/4"                                      | 6    |
| 18       | 220-879  | DRIVE HOUSING KIT<br><i>Includes items 18 a and 18b, and one of item 10</i> | 1    | 64       | 108-865  | SCREW, pnh; 8-32 x 3/8"                                       | 10   |
|          |          |   |      | 69       | 110-814  | NUT, retainer   | 2    |
| 18a      | 183-209  | • BEARING, thrust   | 1    | 71▲      | 177-762  | LABEL, WARNING  | 1    |
| 18b      | 106-227  | • SPACER  | 1    | 75       | 183-461  | ADAPTER; 3/8 npsm x 1/4 npt                                   | 1    |
| 19       | 186-227  | HANGER, pail  | 1    | 77       | 290-060  | LABEL, IDENTIFICATION   | 1    |
| 20       | 183-210  | PIN, straight, 3/8 x 1-1/8"   | 1    | 81       | 185-384  | BRACKET   | 2    |
| 21       | 100-644  | SCREW, soc head, no. 1/4-20 x 3/4"  | 2    | 82       | 110-240  | NUT   | 2    |
| 22       | 065-312  | CONDUIT, electrical, 13 in.   | 1    | 84       | 106-078  | SCREW, flat hd; 10-24 x 3/8"                                  | 4    |
| 23       |          | POWER SUPPLY CORD   | 1    | 85       | 100-040  | PLUG  | 1    |
|          | 238-342  | • For Models 231-351, 231-352   | 1    | 87       | 106-170  | BUSHING, strain relief  | 1    |
|          | 238-167  | • For Model 223-773   | 1    | 88       | 185-565  | LABEL, control  | 1    |
| 24       | 107-264  | TERMINAL, female  | 2    | 89       | 100-035  | SCREW, pnh; 8-32 x 5/16"<br><i>inside pressure control</i>    | 1    |
| 26       | 154-636  | WASHER  | 2    | 90       | 157-021  | LOCKWASHER, internal, No. 8<br><i>inside pressure control</i> | 1    |
| 27       | 220-639  | BEARING HOUSING KIT   | 1    | 91       | 100-020  | LOCKWASHER, .194" ID  | 2    |
| 28       | 150-513  | NUT, jam; 7/16"   | 2    | 92       | 187-656  | GASKET  | 2    |
| 29       | 220-640  | CONNECTING ROD KIT  | 1    | 93       | 110-619  | LABEL, Caution  | 1    |
| 30       | 100-643  | SCREW, socket head, no. 1/4-20 x 1"   | 2    | 95       | 178-035  | LABEL, Caution  | 1    |
| 31       | 183-168  | COVER, housing  | 1    | 97▲      | 185-951  | LABEL, DANGER   | 1    |
| 32       | 108-850  | SCREW, filh; no. 8-32 x 1-1/4"  | 4    | 98▲      | 185-952  | LABEL, DANGER   | 2    |
| 33       | 110-141  | CAPSCREW, sch; 3/8-16 x 1-1/5"  | 4    | 99▲      | 185-955  | LABEL, DANGER   | 1    |
| 34       | 186-374  | ADAPTER, elbow, special; 1/4-18 npt(m x f)                                  | 1    | 100      | 186-490  | CLIP, spring  | 1    |
| 35       | 183-169  | SPRING, retaining   | 1    | 101      | 186-495  | TUBE, drain   | 1    |
| 36       | 185-000  | COVER, pressure control   | 1    | 102      | 181-102  | CLIP, spring  | 1    |
| 37       | 110-963  | CAPSCREW, flange head, 5/16-18 x 3/4"                                       | 7    | 103      | 107-447  | SEAL  | 2    |
| 38       | 183-170  | NUT, hex, 1 13/16 unc-2b  | 1    | 107      | 112-152  | SWITCH, circuit breaker, 110V                                 | 1    |
| 39       | 220-872  | DISPLACEMENT PUMP <i>see page 24</i>  | 1    | 108      | 105-659  | BOOT, toggle  | 1    |
| 40       | 100-214  | LOCKWASHER, spring; 5/16"   | 7    |          | 105-679  | SWITCH, toggle  | 1    |
| 41       | 100-188  | NUT, heavy hex; 5/16-18 unc-2a  | 7    | 109      | 113-605  | BOOT, circuit breaker   | 1    |
| 42       | 183-423  | TUBE, INTAKE  | 1    |          |          |   |      |

▲ Replacement Danger and Warning labels, tags and cards are available at no cost.

# Displacement Pump Parts Drawing and List

## Model 220-872, Series A

Displacement Pump  
Includes items 202 to 225

| Ref. No. | Part No. | Description               | Qty. |
|----------|----------|---------------------------|------|
| 202*     | 107-098  | PACKING, o-ring, PTFE     | 1    |
| 203*     | 108-690  | SEAL, u-cup, polyurethane | 1    |
| 204*     | 108-775  | BALL; sst                 | 1    |
| 205      | 183-171  | PLUG 1                    | 1    |
| 206*     | 183-174  | V-PACKING, leather        | 2    |
| 207*     | 183-175  | V-PACKING, leather        | 2    |
| 208*     | 183-176  | GLAND, male               | 1    |
| 209*     | 183-177  | GLAND, female             | 1    |
| 210*     | 183-178  | GLAND, male               | 1    |
| 211      | 183-179  | NUT, hex, retaining       | 1    |
| 212*     | 183-182  | V-PACKING, plastic        | 3    |
| 213*     | 183-183  | V-PACKING, plastic        | 3    |
| 214*     | 183-653  | WASHER, backup            | 1    |
| 215*     | 183-185  | GLAND, female             | 1    |
| 216      | 183-186  | NUT, packing              | 1    |
| 217*     | 183-172  | O-RING, PTFE              | 1    |
| 218      | 183-361  | SLEEVE, cylinder          | 1    |
| 219      | 183-181  | CYLINDER                  | 1    |
| 220      | 183-180  | GUIDE, ball               | 1    |
| 221*     | 183-173  | PIN, ball stop            | 1    |
| 222      | 220-631  | VALVE, piston             | 1    |
| 223      | 220-629  | VALVE, intake             | 1    |
| 224      | 220-630  | ROD, piston               | 1    |
| 225*     | 101-947  | BALL                      | 1    |

\* These parts are also included in Repair Kit 220-877, which may be purchased separately.

### SLEEVE REMOVAL TOOL 220-991

Use to remove a sleeve that is stuck.  
Purchase separately.

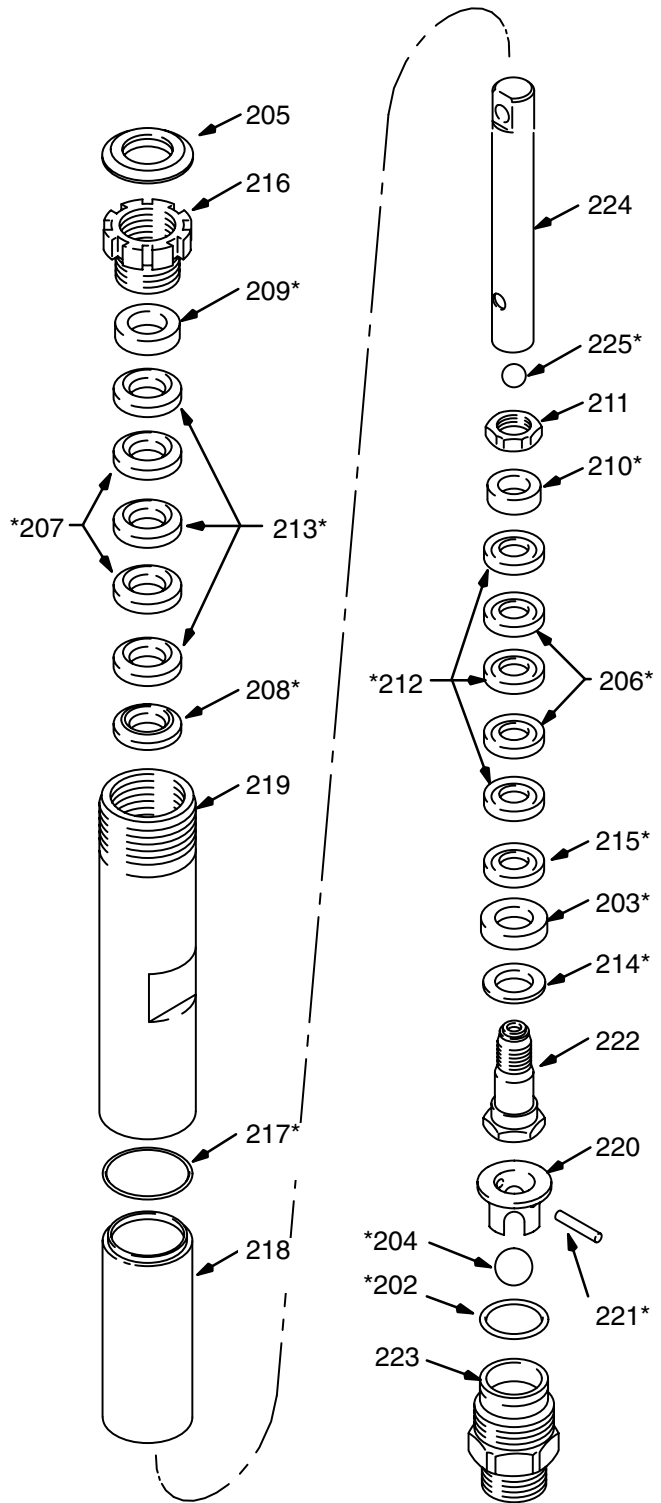



# Accessories

## DANGER LABELS

The English language DANGER label shown on page 1 is also on your sprayer. If you have painters who do not read English, order one of the following labels to apply to your sprayer. The drawing below shows the best placement of these labels for good visibility.

Order the labels directly from Graco, free of charge. Toll Free: **1-800-367-4023**

**French 185-956**  
**Spanish 185-961**  
**German 186-041**  
**Greek 186-045**  
**Korean 186-049**  
**English 185-953**

Apply other language here

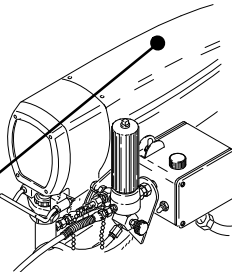

## MOTOR BRUSH KIT 220-853

## DISPLACEMENT PUMP PACKING KIT 220-877

See contents on page 24.

## SUCTION TUBE KIT 208-920

5 gallon (19 liter) size  
Includes:

| Ref No. | Part No. | Description                       | Qty |
|---------|----------|-----------------------------------|-----|
| 1       | 101-818  | CLAMP, hose                       | 2   |
| 2       | 160-327  | UNION, 90° swlvel; 3/4 npt(m x f) | 1   |
| 3       | 170-705  | ADAPTER, intake                   | 1   |
| 4       | 170-706  | HOSE, 1" ID x 48"; nylon          | 1   |
| 5       | 170-957  | TUBE, suction                     | 1   |
| 6       | 181-072  | STRAINER                          | 1   |

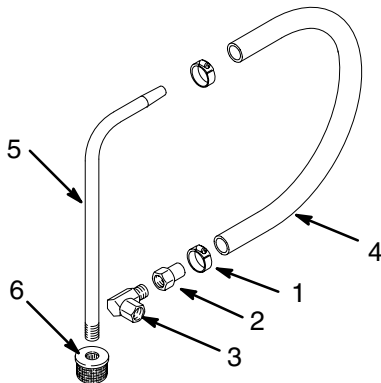

0161

## SUCTION TUBE KIT 208-259

55 gallon (200 liter) size  
Includes:

| Ref No. | Part No. | Description   | Qty |
|---------|----------|---|-----|
| 1       | 156-589  | UNION, 90°; 3/4 npt(f) x 3/4 npt(f) sw                                      | 1   |
| 2       | 214-961  | HOSE, cpld 3/4 npt(mbe); 3/4" ID; nylon; 6 ft (1.8 m); spring guard one end | 1   |
| 3       | 156-591  | ELBOW, 90°; 3/4 npt x 1-1/2 - 24 ns   | 1   |
| 4       | 156-593  | PACKING, o-ring, nitrile  | 1   |
| 5       | 100-220  | THUMBSCREW, 5/16-18 X 1"  | 1   |
| 6       | 176-684  | ADAPTER, bung   | 1   |
| 7       | 156-592  | TUBE, riser   | 1   |
| 8       | 159-100  | RETAINER, screen  | 1   |
| 9       | 161-377  | SCREEN, filter  | 1   |
| 10      | 159-101  | NUT, screen retainer  | 1   |

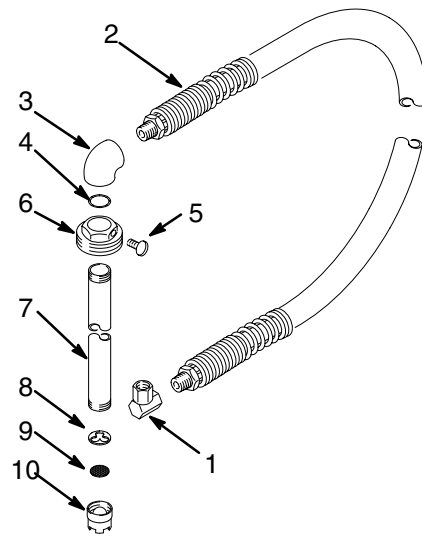

0162



# Technical Data

Power Requirements (full output) . . . . . 120 VAC, 60Hz,  
1 phase, 18 amp minimum  
Working Pressure Range . . . . . 0–3000 psi  
(0–21.0 MPa, 0 – 210 bar)  
Cycles/Gallon (liter) . . . . . 104 (27.5)  
Power Cord . . . . . No. 12 AWG, 3 wire, 10' (3 m)  
Inlet Paint Strainer . . . . . 16 mesh (1190 micron)  
Stainless steel screen, reusable  
Outlet Paint Filter . . . . . 60 mesh (250 micron)  
Stainless steel screen, reusable  
Pump Inlet Size . . . . . 3/4 npt(m)  
Fluid Outlet Size . . . . . 1/4 npsm from fluid filter  
Wetted Parts:  
*Displacement Pump* . . . . . Carbon steel, Polyurethane,  
Polyethylene, PTFE, Delrin®, Leather  
*Filter* . . . . . Aluminum, Carbon steel, Stainless steel,

**NOTE:** Delrin®

# Dimensions

|        |                    |
|--------|--------------------|
| Weight | 122 lb (55.5 kg)   |
| Height | 32 in. (813 mm)    |
| Length | 24.25 in. (616 mm) |
| Width  | 22.5 in. (572 mm)  |

# Graco Standard Warranty

Graco warrants all equipment manufactured by Graco and bearing its name to be free from defects in material and workmanship on the date of sale by an authorized Graco distributor to the original purchaser for use. With the exception of any special, extended, or limited warranty published by Graco, Graco will, for a period of twelve months from the date of sale, repair or replace any part of the equipment determined by Graco to be defective. This warranty applies only when the equipment is installed, operated and maintained in accordance with Graco's written recommendations.

This warranty does not cover, and Graco shall not be liable for general wear and tear, or any malfunction, damage or wear caused by faulty installation, misapplication, abrasion, corrosion, inadequate or improper maintenance, negligence, accident, tampering, or substitution of non-Graco component parts. Nor shall Graco be liable for malfunction, damage or wear caused by the incompatibility of Graco equipment with structures, accessories, equipment or materials not supplied by Graco, or the improper design, manufacture, installation, operation or maintenance of structures, accessories, equipment or materials not supplied by Graco.

This warranty is conditioned upon the prepaid return of the equipment claimed to be defective to an authorized Graco distributor for verification of the claimed defect. If the claimed defect is verified, Graco will repair or replace free of charge any defective parts. The equipment will be returned to the original purchaser transportation prepaid. If inspection of the equipment does not disclose any defect in material or workmanship, repairs will be made at a reasonable charge, which charges may include the costs of parts, labor, and transportation.

**THIS WARRANTY IS EXCLUSIVE, AND IS IN LIEU OF ANY OTHER WARRANTIES, EXPRESS OR IMPLIED, INCLUDING BUT NOT LIMITED TO WARRANTY OF MERCHANTABILITY OR WARRANTY OF FITNESS FOR A PARTICULAR PURPOSE.**

Graco's sole obligation and buyer's sole remedy for any breach of warranty shall be as set forth above. The buyer agrees that no other remedy (including, but not limited to, incidental or consequential damages for lost profits, lost sales, injury to person or property, or any other incidental or consequential loss) shall be available. Any action for breach of warranty must be brought within two (2) years of the date of sale.

Graco makes no warranty, and disclaims all implied warranties of merchantability and fitness for a particular purpose in connection with accessories, equipment, materials or components sold but not manufactured by Graco. These items sold, but not manufactured by Graco (such as electric motors, switches, hose, etc.), are subject to the warranty, if any, of their manufacturer. Graco will provide purchaser with reasonable assistance in making any claim for breach of these warranties.

In no event will Graco be liable for indirect, incidental, special or consequential damages resulting from Graco supplying equipment hereunder, or the furnishing, performance, or use of any products or other goods sold hereto, whether due to a breach of contract, breach of warranty, the negligence of Graco, or otherwise.

## **FOR GRACO CANADA CUSTOMERS**

The parties acknowledge that they have required that the present document, as well as all documents, notices and legal proceedings entered into, given or instituted pursuant hereto or relating directly or indirectly hereto, be drawn up in English. Les parties reconnaissent avoir convenu que la rédaction du présente document sera en Anglais, ainsi que tous documents, avis et procédures judiciaires exécutés, donnés ou intentés à la suite de ou en rapport, directement ou indirectement, avec les procédures concernées.

## Graco Phone Number

**TO PLACE AN ORDER**, contact your Graco distributor, or call this number to identify the distributor closest to you:  
**1-800-367-4023 Toll Free.**

## Manual Change Summary

Models 231-351 and 231-352 are obsolete and were removed from this manual.

*All written and visual data contained in this document reflects the latest product information available at the time of publication.  
Graco reserves the right to make changes at any time without notice.*

**Sales Offices:** Minneapolis, Detroit, Los Angeles  
**Foreign Offices:** Belgium, Canada, England, Korea, France, Germany, Hong Kong, Japan

**GRACO INC. P.O. BOX 1441 MINNEAPOLIS, MN 55440-1441**

**<http://www.graco.com>**

PRINTED IN U.S.A. 308-551 December 1994, Revised December 1997