

5:1 Ratio Bulldog[®] Pump

307871J

500 psi (35 bar, 3.5 MPa) Maximum Working Pressure

100 psi (7 bar, 700 KPa) Maximum Air Input Pressure

Part No. 221104, Series B

With a Severe-Duty Displacement Pump*

* Severe-Duty Displacement Pumps have an abrasion and corrosion-resistant displacement rod and sleeve. Refer to the Technical Data in the separate displacement pump manual 308043 for wetted parts information.



Important Safety instructions

Read all warnings and instructions in this manual.
Save these instructions. See page 2 for Table of Contents.

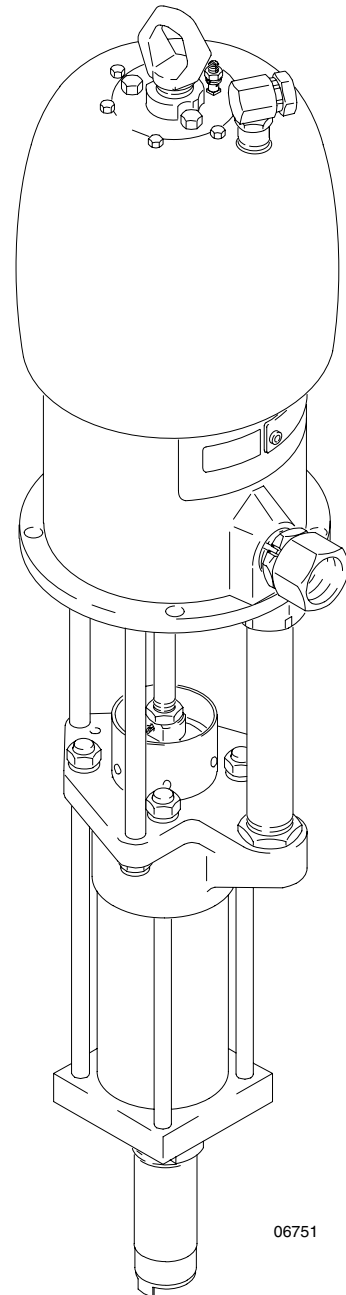

06751

PROVEN QUALITY. LEADING TECHNOLOGY.

CE 0359 Ex II 1/2 G T2
ITS03ATEX11229

Table of Contents

Warnings	2	Parts	10
Installation	4	Dimensional Drawings	11
Operation	6	Mounting Hole Layout	11
Troubleshooting	8	Technical Data	11
Service	9	Graco Standard Warranty	12
		Graco Information	12

Symbols

Warning Symbol



This symbol alerts you to the possibility of serious injury or death if you do not follow the instructions.

Caution Symbol



This symbol alerts you to the possibility of damage to or destruction of equipment if you do not follow the instructions.

! WARNING



INSTRUCTIONS

EQUIPMENT MISUSE HAZARD

Equipment misuse can cause the equipment to rupture or malfunction and result in serious injury.

- This equipment is for professional use only.
- Read all instruction manuals, tags, and labels before operating the equipment.
- Use the equipment only for its intended purpose. If you are not sure, call your Graco distributor.
- Do not alter or modify this equipment. Use only genuine Graco parts and accessories.
- Check equipment daily. Repair or replace worn or damaged parts immediately.
- Do not exceed the maximum working pressure stated on the equipment or in the **Technical Data** for your equipment. Do not exceed the maximum working pressure of the lowest rated component in your system.
- Use fluids and solvents which are compatible with the equipment wetted parts. Refer to the **Technical Data** section of all equipment manuals. Read the fluid and solvent manufacturer's warnings.
- Handle hoses carefully. Do not use hoses to pull equipment.
- Route hoses away from traffic areas, sharp edges, moving parts, and hot surfaces. Do not expose Graco hoses to temperatures above 66°C (150°F) or below -40°C (-40°F).
- Wear hearing protection when operating this equipment.
- Do not lift pressurized equipment.
- Comply with all applicable local, state, and national fire, electrical, and safety regulations.

WARNING



FIRE AND EXPLOSION HAZARD

Improper grounding, poor ventilation, open flames or sparks can cause a hazardous condition and result in a fire or explosion and serious injury.

- Ground the equipment and the object being sprayed. Refer to **Grounding** on page 4.
- If there is any static sparking or you feel an electric shock while using this equipment, **stop spraying immediately**. Do not use the equipment until you identify and correct the problem.
- Provide fresh air ventilation to avoid the buildup of flammable fumes from solvents or the fluid being sprayed.
- Keep the spray area free of debris, including solvent, rags, and gasoline.
- Before operating this equipment, electrically disconnect all equipment in the spray area.
- Before operating this equipment, extinguish all open flames or pilot lights in the spray area.
- Do not smoke in the spray area.
- Do not turn on or off any light switch in the spray area while operating or if fumes are present.
- Do not operate a gasoline engine in the spray area.



TOXIC FLUID HAZARD

Hazardous fluid or toxic fumes can cause serious injury or death if splashed in the eyes or on the skin, inhaled, or swallowed.

- Know the specific hazards of the fluid you are using.
- Store hazardous fluid in an approved container. Dispose of hazardous fluid according to all local, state and national guidelines.
- Always wear protective eyewear, gloves, clothing and respirator as recommended by the fluid and solvent manufacturer.



MOVING PARTS HAZARD

Moving parts can pinch or amputate your fingers.

- Keep clear of all moving parts when starting or operating the pump.
- Before checking or servicing the equipment, follow the **Pressure Relief Procedure** on page 6 to prevent the equipment from starting unexpectedly.

Installation

Grounding

Proper grounding is an essential part of maintaining a safe system.

To reduce the risk of static sparking, ground the pump. Check your local electrical code for detailed grounding instructions for your area and type of equipment. Be sure to ground all of this equipment:

1. *Pump:* use a ground wire and clamp as shown below.
2. *Air and fluid hoses:* use only electrically conductive hoses with a maximum 500 ft (150 m) combined hose length to ensure grounding continuity.
3. *Air compressor:* follow manufacturer's recommendations.
4. *Spray gun:* grounding is obtained through connection to a properly grounded fluid hose and pump.
5. *Object being sprayed:* follow your local code.
6. *Fluid supply container:* follow your local code.
7. *All solvent pails used when flushing or relieving pressure,* always hold a metal part of the gun firmly to the side of a grounded metal pail, then trigger the gun.

- *To maintain grounding continuity when flushing or relieving pressure,* always hold a metal part of the spray gun firmly to the side of a grounded metal pail, then trigger the spray gun.

To ground the pump:

To ground the pump, loosen the grounding lug locknut (W) and washer (X). Insert one end of a 12 ga (1.5 mm²) minimum ground wire (Y) into the slot in lug (Z) and tighten the locknut securely. Connect the other end of the wire to a true earth ground. Order Part No. 237569, Ground Wire and Clamp.

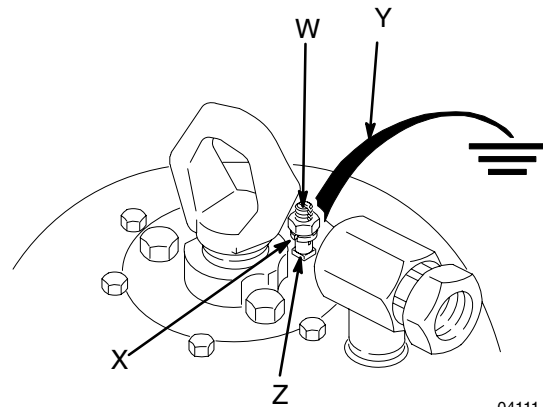
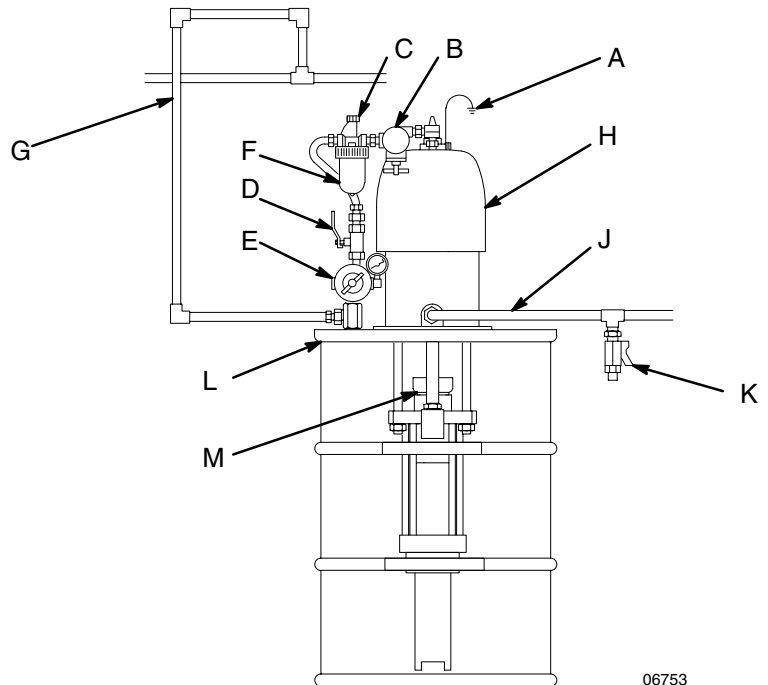

Fig. 1

04111

Installation

Typical Installation



KEY

- A Ground Wire
- B Pump Runaway Valve
- C Air Motor Lubricator
- D Bleed-Type Master Air Valve
- E Air Regulator and Gauge
- F Air Line Filter
- G Electrically Conductive Air Supply Line
- H Pump
- J Fluid Outlet Hose
- K Fluid Drain Valve
- L 55 Gallon Drum Cover
- M Wet-Cup

NOTE: Reference numbers and letters in parentheses in the text refer to the callouts in the figures and the parts drawings.

1. Mount the pump to suit the type of installation planned. The pump dimensions and mounting hole layout are shown on page 11.
2. The Typical Installation shown above is only a guide. Contact your Graco distributor for assistance in designing a system to suit your needs.
3. Install the accessories as explained in the following steps. If you supply your own accessories, be sure they are adequately sized for you system.

4. Install the air line accessories in the approximate order shown. To reduce stress on the air inlet fitting, do not mount any accessories directly at the air inlet fitting. Mount accessories on a bracket or other fixture and use a hose between the accessories and air inlet. Use the shortest practical length of hose.

The pump runaway valve (B) stops the supply of air to the pump if the pump begins to run too fast, which usually indicates a depleted fluid supply.

The air motor lubricator (C) automatically lubricates the motor. Adjust the lubricator to dispense about one drop of lubricant per minute.

The air regulator and gauge (E) controls pump speed and fluid pressure.

The air filter (F) removes dirt and moisture from the compressed air supply. Damp or dirty air can damage the air motor.

Use electrically conductive air hoses. Connect an electrically conductive air supply hose (G) to the main air supply line. Read the **Fire and Explosion Hazard** on page 3.

5. Install a fluid drain valve (K) close to the pump fluid outlet. Read the **Warning** to the left. Use a fluid filter (not shown), if needed.
6. Connect an electrically conductive fluid outlet hose (J) to the pump. Read the warning section **Fire and Explosion Hazard** on page 3.

WARNING

Two accessories, the bleed-type master air valve (D), and the fluid drain valve (K) are required in your system to reduce the risk of serious injury from moving parts or splashing fluid in the eyes or on the skin when shutting off the pump.

The Bleed-Type Master Air Valve relieves air trapped between the valve and the pump, after the pump is shut off. Trapped air can cause the pump to cycle unexpectedly and result in serious bodily injury if you are adjusting or repairing the pump.

The Fluid Drain Valve helps relieve fluid pressure in the displacement pump, hose, and gun/dispensing valve when shutting off the pump. Triggering the gun/dispensing valve may not be sufficient, especially if there is a clog in the hose, gun/dispensing valve, or tip/nozzle.

Operation

NOTE: Flush the pump before using it for the first time to remove the lightweight oil which is left in the pump after factory testing it. The oil protects the pump from corrosion. Be sure the solvent used is compatible with the fluid to be sprayed, and with the wetted parts of the pump. Refer to the Technical Data on page 11 and in the separate displacement pump manual for the wetted parts.

Pressure Relief Procedure

WARNING

PRESSURIZED EQUIPMENT HAZARD



The system pressure must be manually relieved to prevent the system from starting or spraying accidentally. Fluid under high pressure can be injected through the skin and cause serious injury. To reduce the risk of an injury from injection, splashing fluid, or moving parts, follow the **Pressure Relief Procedure** whenever you:

- are instructed to relieve the pressure,
- stop spraying,
- check or service any of the system equipment,
- or install or clean the spray tips.

1. Shut off the air to the pump.
2. Close the bleed-type master air valve (required in your system).
3. Hold a metal part of the gun to the side of a grounded metal pail and trigger the gun to relieve pressure.
4. Open the fluid drain valve (required in your system), having a container ready to catch the drainage.

*If you suspect that the spray tip or hose is clogged or that fluid pressure is not fully relieved after following the steps above, **very slowly** loosen the tip guard retaining nut or hose end coupling and relieve pressure gradually. Clear the tip or hose obstruction.*

Check Valve Adjustment

The fluid piston and intake valve are factory set for high-volume pumping of heavy, spray-viscosity fluids. To adjust the check valves, refer to the **Operation** section in the separate displacement pump manual.

Starting and Adjusting the Pump

NOTE: If the pump is not immersed in fluid, fill the wet-cup (M) 1/2 full with Graco Throat Seal Liquid (TSL) or a compatible solvent.

1. Open the bleed-type master air valve.
2. Open the spray gun or dispensing valve.
3. Slowly open the air regulator until the pump is running at about 40 psi (3 bar, 300 KPa) air pressure. Run the pump slowly until all the air is pushed out of the lines and fluid is flowing smoothly. Close the spray gun or dispensing valve; the pump will stall.

NOTE: In a direct supply system, the pump starts and stops automatically when the spray gun or dispensing valve is opened or closed, if the pump is supplied with sufficient air pressure and air volume.

In a circulating system, the pump runs continuously, speeding up or slowing down as the spray gun or dispensing valve is opened and closed, until the air supply is shut off.

Lubrication

1. For automatic air motor lubrication, install an air line lubricator. Refer to step 4 of installation. Lubrication helps keep the motor running smoothly and prolongs its life.
2. Keep the displacement pump wet-cup 1/2 full with TSL or a compatible solvent. This prolongs the life of the displacement pump packings.

Operation

Flushing

WARNING

To reduce the risk of serious injury whenever you are instructed to relieve pressure, always follow the **Pressure Relief Procedure** on page 6.

Your fluid supplier should be able to tell you the rate at which your fluid dries, or its contents settle during non-use. Flush the pump frequently enough to prevent the fluid from drying or settling in the pump and hoses to prevent costly damage. Use a compatible solvent. Refer to the **Technical Data** on page 11 and in the separate displacement pump manual for a list of the wetted parts.

If you are pumping water-based fluid, first flush with water and then with a compatible solvent.

Water, or even moist air, can cause your pump to corrode. Read and follow the **Caution** below.

CAUTION

Never leave water or water-base fluid in the pump overnight. If you are pumping water-base fluid, flush with water first, then with a rust inhibitor such as mineral spirits. Relieve the pressure, but leave the rust inhibitor in the pump to protect the parts from corrosion.

Keep the Fluid Supply Container Filled

If your pump is running too fast, or accelerates quickly, it is probably out of fluid. Shut off the air supply immediately to prevent damage to the pump. Check the fluid supply frequently and replenish it as needed. If the fluid supply is empty, and air has been sucked into the fluid lines, be sure to prime the pump again before regular operation.

Shutdown

WARNING

To reduce the risk of serious injury whenever you are instructed to relieve pressure, always follow the **Pressure Relief Procedure** on page 6.

Always stop the pump with the displacement rod in the down position. This prevents fluid from drying on the displacement rod and damaging the packings when the pump is restarted.

Relieve the pressure whenever you shut off the pump.

Troubleshooting

WARNING

To reduce the risk of serious injury whenever you are instructed to relieve pressure, always follow the **Pressure Relief Procedure** on page 6.

Relieve the Pressure before you check or service any system equipment.

NOTE: Check all other possible problems and solutions before disassembling the pump.

Problem	Cause	Solution
Pump fails to operate	Restricted air line or inadequate air supply	Clear the line. See the Technical Data on page 11 for air volume requirements.
	Insufficient air pressure	Increase air pressure – the pump will not operate below 30 psi (2.1 bar, 210 KPa) air pressure.
	Closed or clogged valves or regulators on the air and/or fluid side of the system.	Check the valves and regulators and adjust or clean as needed.
	Fluid has dried on the displacement rod	Clean. See displacement pump manual 308043. Also, keep TSL in the pump wet-cup, and stop the pump at the bottom of its stroke during non-use.
	Air motor is dirty, worn, or damaged	Service the motor. See manual 307049. Be sure the air supply is clean and dry, and that the motor is properly lubricated.
Pump operates, but the fluid output is low on both strokes	Empty fluid supply container	Refill the fluid supply container
	Restricted air line or inadequate air supply	Clear the lines. See the Technical Data on page 11 for air volume requirements.
	Insufficient air pressure	Increase air pressure – the pump will not operate below 30 psi (2.1 bar, 210 KPa) air pressure.
	Fluid hose or gun is clogged	Clean the hose or gun, flush frequently.
	Fluid is too heavy for the pump to prime	Use an inductor plate or ram.
	Loose packing nut or worn throat packings	Tighten packing nut or replace packings as needed. See manual 308043.
	Ball travel restricted too much for the viscosity of fluid being pumped.	See Check Valve Adjustment in manual 308043.
Pump operates, but the output is low on the down stroke	Fluid is too heavy for the pump to prime	Use an inductor plate or ram.
	Damaged cylinder o-rings	Replace o-rings. See manual 308043.
	The intake valve is stuck open or worn	Check; replace parts as needed. See manual 308043.
	Ball travel restricted too much for the viscosity of fluid being pumped.	See Check Valve Adjustment in manual 308043
Pump operates, but the output is low on the upstroke	The piston valve is stuck open or the packings are worn	Check, replace parts as needed. See manual 308043
	Damaged cylinder o-rings	Replace o-rings. See manual 308043
Pumps is operating erratically, or speeds up suddenly	Empty fluid supply container	Refill. Also see Operation on page 6.
	Fluid hose or gun is clogged	Clean the hose or gun. Flush frequently.
	The piston valve is stuck open or the packings are worn	Check, replace parts as needed. See manual 308043.
	The intake valve is stuck open or worn	Check; replace parts as needed. See manual 308043.
	Loose packing nut or worn throat packings	Tighten packing nut or replace packings as needed. See manual 308043.

Service

General Information

- Follow the torque and assembly notes on page 10.
- To service the air motor, refer to manual 307049, supplied.
- To service the displacement pump, refer to manual 308043, supplied.

Disassembly (See page 10)

WARNING

To reduce the risk of serious injury whenever you are instructed to relieve pressure, always follow the **Pressure Relief Procedure** on page 6.

1. Flush the pump with a compatible solvent, **relieve the pressure**, and stop the pump at the bottom of its stroke.
2. Disconnect the hoses from the pump. Remove the pump from its mounting and clamp it in a vise.
3. Remove the upper cotter pin (1). Unscrew the coupling nut (8). Unscrew the three tie rod locknuts (3). Unscrew the nut (56) be sure not to lose the two rings (57, 58). Carefully pull the displacement pump (12) away from the air motor (11).
4. Remove the lower cotter pin (1). Loosen the locknut (4). Unscrew the connecting rod (9) from the displacement rod (N). The pipe (53) slides out of the air motor as the pump is detached

Reassembly (See page 10)

1. If removed, screw the three tie rods (6) into the motor (11).
2. If removed, screw the bushing (59) into the outlet of the displacement pump (12). Screw the riser tube (53) into the bushing (59).
3. Screw the connecting rod (9) into the displacement rod (N). Install the cotter pin (1) and tighten the locknut (4).
4. Make sure the riser tube rings (57, 58) are in place. Guide the displacement pump (12) onto the tie rods (6), so the outlet of the displacement pump is aligned with the auxiliary outlet of the motor (11). The riser tube (53) will slide into the motor. Screw the nut (56) onto the elbow (60) loosely.
5. Install the locknuts (3) on the tie rods. Torque the nuts to 40–50 ft-lb (54–68 N•m).
6. Tighten the coupling nut (8). Insert the upper cotter pin (1) through the coupling (7). Tighten the riser tube nut (56).
7. Connect the hoses to the pump. Run the pump slowly to be sure it runs smoothly and does not bind. If necessary, adjust the displacement pump tie rods and locknuts (see manual 308043), or the tie rods (6) and locknuts (3) which attach the motor, to eliminate binding.
8. Reconnect the ground wire to the motor.

Parts

- 1 Torque to 40–50 ft-lbs (54–68 N•m)
- 2 Apply lubricant
- 3 Apply sealant to threads
- 4 Apply lubricant to top thread of rod

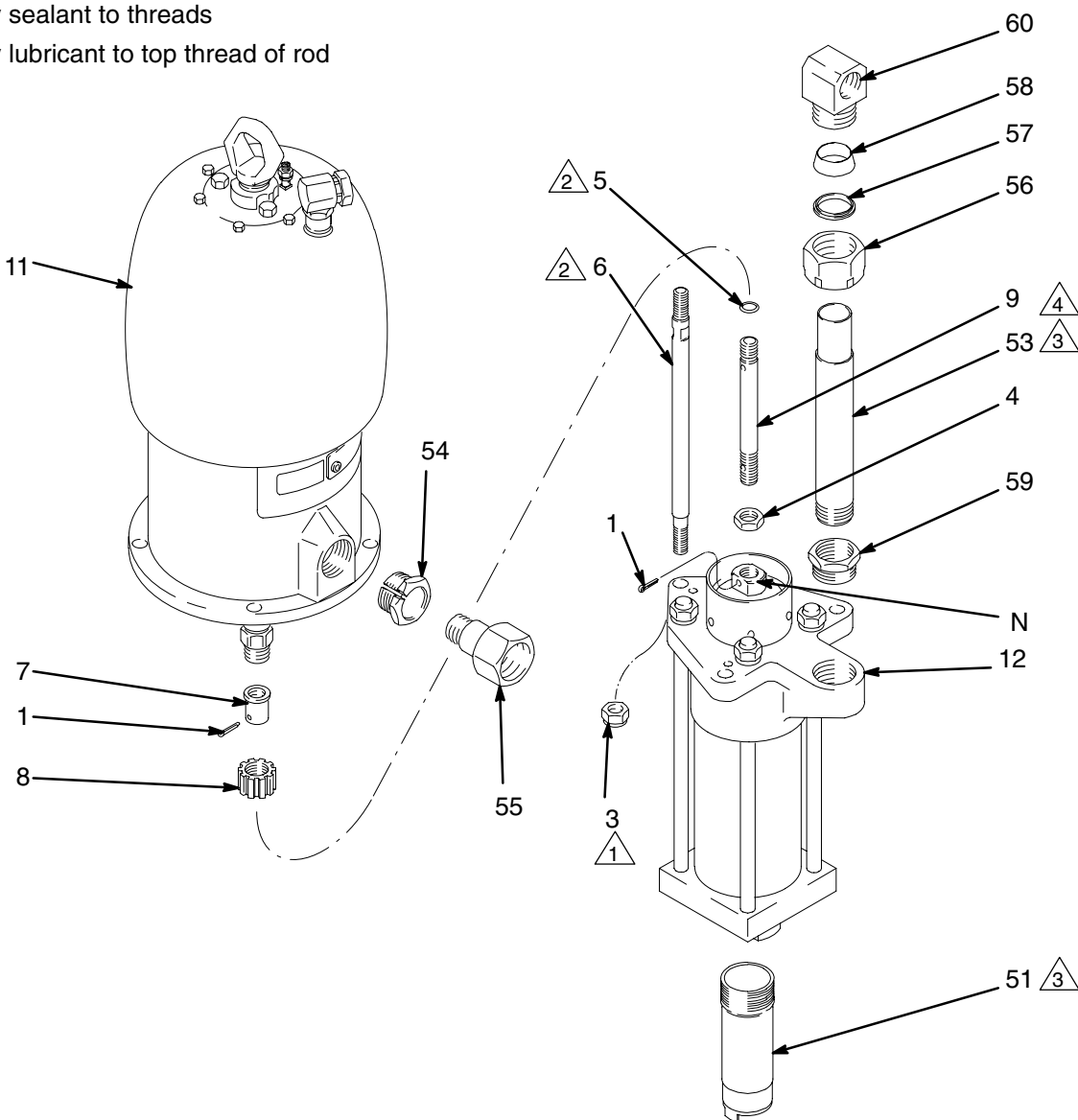

06752

Ref No.	Part No.	Description	Qty.	Ref No.	Part No.	Description	Qty.
1	100103	PIN, cotter; 1.5" long	2	12	210208	DISPLACEMENT PUMP	1
3	101712	LOCKNUT; 5/8–11; with nylon insert	3	51	161612	TUBE, intake extension	1
4	101936	NUT, hex, jam; 3/4–10	1	53	190397	TUBE, riser	1
5	158674	O-RING; nitrile ribber	1	54	166153	NUT, collet	1
6	161541	ROD, tie; 13.5" (343 mm) long	3	55	190401	ADAPTER	1
7	161543	COUPLING, connecting rod	1	56	190398	NUT, tube	1
8	161544	NUT, coupling	1	57	190399	RING	1
9	164444	ROD, connecting; 7.325" (186 mm)	1	58	190400	RING	1
11	208356	AIR MOTOR See manual 307049 for parts	1	59	112972	BUSHING	1
				60	190402	ELBOW	1

Dimensions

Mounting Hole Layout

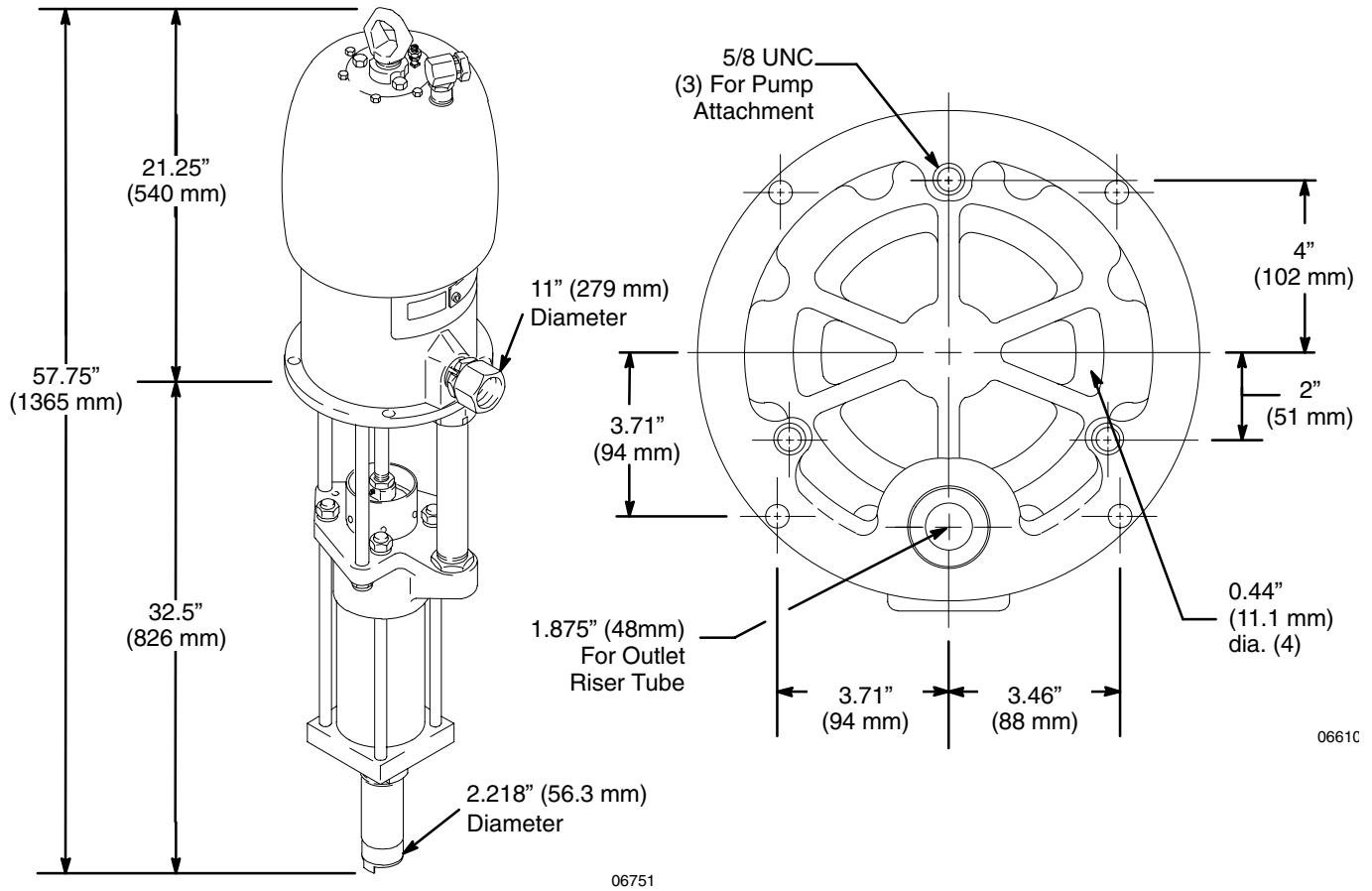

Technical Data

Air operating range	30 psi (2.1 bar, 210 KPa) min. to 100 psi (7 bar, 700 KPa) max.
Maximum fluid pressure	500 psi (35 bar, 3.5 MPa) at a maximum 100 psi (7 bar, 700 KPa) air input
Air consumption	5.3 CFM (0.15 m ³) at 1 gallon (3.78 l) at 100 psi (7 bar, 700 KPa) air input
Cycles per gallon (liter)	3.3 (0.87)
Maximum recommended pump speed	60 cycles/min
Air inlet size	3/4 npt
Fluid outlet size	1-1/2" npt
Fluid inlet size	2" npt
Wetted parts	<i>Intake and Riser Tubes: Zinc-Plated Steel, Displacement Pump: See Manual 308043</i>

Graco Standard Warranty

Graco warrants all equipment manufactured by Graco and bearing its name to be free from defects in material and workmanship on the date of sale to the original purchaser for use. With the exception of any special, extended, or limited warranty published by Graco, Graco will, for a period of twelve months from the date of sale, repair or replace any part of the equipment determined by Graco to be defective. This warranty applies only when the equipment is installed, operated and maintained in accordance with Graco's written recommendations.

This warranty does not cover, and Graco shall not be liable for general wear and tear, or any malfunction, damage or wear caused by faulty installation, misapplication, abrasion, corrosion, inadequate or improper maintenance, negligence, accident, tampering, or substitution of non-Graco component parts. Nor shall Graco be liable for malfunction, damage or wear caused by the incompatibility of Graco equipment with structures, accessories, equipment or materials not supplied by Graco, or the improper design, manufacture, installation, operation or maintenance of structures, accessories, equipment or materials not supplied by Graco.

This warranty is conditioned upon the prepaid return of the equipment claimed to be defective to an authorized Graco distributor for verification of the claimed defect. If the claimed defect is verified, Graco will repair or replace free of charge any defective parts. The equipment will be returned to the original purchaser transportation prepaid. If inspection of the equipment does not disclose any defect in material or workmanship, repairs will be made at a reasonable charge, which charges may include the costs of parts, labor, and transportation.

THIS WARRANTY IS EXCLUSIVE, AND IS IN LIEU OF ANY OTHER WARRANTIES, EXPRESS OR IMPLIED, INCLUDING BUT NOT LIMITED TO WARRANTY OF MERCHANTABILITY OR WARRANTY OF FITNESS FOR A PARTICULAR PURPOSE.

Graco's sole obligation and buyer's sole remedy for any breach of warranty shall be as set forth above. The buyer agrees that no other remedy (including, but not limited to, incidental or consequential damages for lost profits, lost sales, injury to person or property, or any other incidental or consequential loss) shall be available. Any action for breach of warranty must be brought within two (2) years of the date of sale.

Graco makes no warranty, and disclaims all implied warranties of merchantability and fitness for a particular purpose in connection with accessories, equipment, materials or components sold but not manufactured by Graco. These items sold, but not manufactured by Graco (such as electric motors, switches, hose, etc.), are subject to the warranty, if any, of their manufacturer. Graco will provide purchaser with reasonable assistance in making any claim for breach of these warranties.

In no event will Graco be liable for indirect, incidental, special or consequential damages resulting from Graco supplying equipment hereunder, or the furnishing, performance, or use of any products or other goods sold hereto, whether due to a breach of contract, breach of warranty, the negligence of Graco, or otherwise.

FOR GRACO CANADA CUSTOMERS

The parties acknowledge that they have required that the present document, as well as all documents, notices and legal proceedings entered into, given or instituted pursuant hereto or relating directly or indirectly hereto, be drawn up in English. Les parties reconnaissent avoir convenu que la rédaction du présente document sera en Anglais, ainsi que tous documents, avis et procédures judiciaires exécutés, donnés ou intentés à la suite de ou en rapport, directement ou indirectement, avec les procédures concernées.

Graco Information

TO PLACE AN ORDER, contact your Graco distributor, or call one of the following numbers to identify the distributor closest to you:

1-800-328-0211 Toll Free

612-623-6921

612-378-3505 Fax

All written and visual data contained in this document reflects the latest product information available at the time of publication. Graco reserves the right to make changes at any time without notice.

This manual contains English. MM 307871

Graco Headquarters: Minneapolis,
International Offices: Belgium, Korea, China, Japan

www.graco.com

1/1989, Revised 5/2007