INSTRUCTIONS

This manual contains important warnings and information.
READ AND RETAIN FOR REFERENCE

5 HORSEPOWER, GASOLINE-POWERED

GM 5000 Airless Paint Sprayer

3000 psi (210 bar) Maximum Working Pressure

Sprayers with Upright Carts

Model 220-886, Series C

Basic sprayer, without hose or gun

Model 231-052

Complete sprayer, with hose and Contractor gun, RAC IV™ DripLess™ Tip Guard, and 517 size SwitchTip™

Sprayers with Lo-Boy Carts

Model 222-488, Series A

Basic sprayer, without hose or gun

Model 231-085

Complete sprayer, with hose and Contractor gun, RAC IV™ DripLess™ Tip Guard, and 517 size SwitchTip™

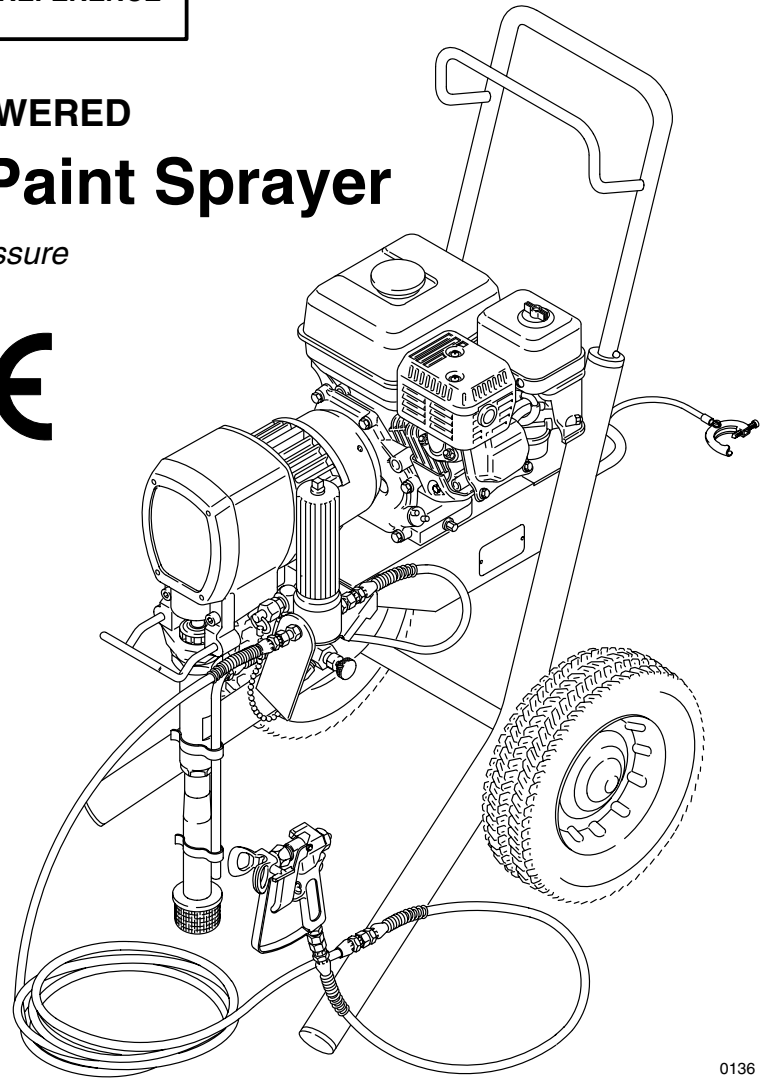

0136

NOTE: This is an example of the DANGER label on your sprayer.
This label is available in other languages, free of charge. See page 42 to order.

 DANGER 	
	FIRE AND EXPLOSION HAZARD
<p>Spray painting, flushing or cleaning equipment with flammable liquids in confined areas can result in fire or explosion.</p> <p>Use outdoors or in extremely well ventilated areas. Ground equipment, hoses, containers and objects being sprayed.</p> <p>Avoid all ignition sources such as static electricity from plastic drop cloths, open flames such as pilot lights, hot objects such as cigarettes, arcs from connecting or disconnecting power cords or turning light switches on and off.</p> <p>Failure to follow this warning can result in death or serious injury.</p>	
	SKIN INJECTION HAZARD
<p>Liquids can be injected into the body by high pressure airless spray or leaks – especially hose leaks.</p> <p>Keep body clear of the nozzle. Never stop leaks with any part of the body. Drain all pressure before removing parts. Avoid accidental triggering of gun by always setting safety latch when not spraying. Never spray without a tip guard.</p> <p>In case of accidental skin injection, seek immediate “Surgical Treatment”.</p> <p>Failure to follow this warning can result in amputation or serious injury.</p>	
READ AND UNDERSTAND ALL LABELS AND INSTRUCTION MANUALS BEFORE USE	

GRACO INC. P.O. BOX 1441 MINNEAPOLIS, MN 55440-1441

©COPYRIGHT 1987, GRACO INC.

Table of Contents

Introduction	2	Clamp	25
Warnings		Clutch Housing	25
English	4	Reassembly	26
French (Avertissement)	6	Pressure Control Replacement	28
Spanish (Advertencia)	8	Pressure Control Adjustment	30
Setup	10	Displacement Pump Repair	31
Fueling	11	Parts Lists and Drawings	
Startup	12	Displacement Pump	34
Maintenance	14	Complete Sprayers	35
Flushing Guidelines	15	Pinion	35
Troubleshooting Guide	16	220–886, Basic Sprayer with Upright cart	36
Repair		222–488, Basic Sprayer with Lo-Boy cart	38
Bearing Housing & Connecting Rod	18	Pressure Control Assembly	40
Drive Housing	19	Accessories	42
Pinion	20	Technical Data	43
Clutch	22	Dimensions	43
Engine	23	Graco Phone Number	43
Field and Wiring Harness	24	Warranty	Back Cover

Introduction

GM5000 BASIC COMPONENTS

NOTE: Refer to Fig. 1.

Your new GM5000 Sprayer functions and operates differently than other airless paint sprayers. This section will help you become familiar with the sprayer before operating it.

Pressure Control

The pressure control includes an ON/OFF switch for the sprayer, the pressure adjusting knob, and a pressure-sensing device. The pressure control engages and disengages the clutch to control pressure.

Engine

The engine is a 5 horsepower, four stroke, gasoline engine. Its function is to drive the displacement pump to supply paint. An adjustable throttle allows you to adjust engine speed for large or small orifice spray tips. When the oil level is too low, the engine shuts off automatically. If you try to start the engine without refilling the oil, a light illuminates to alert you to the problem, and to protect the engine from damage.

Clutch

The clutch is engaged by the electric power generated by the gasoline engine. The power is controlled by the pressure switch.

Drive Assembly

The permanently greased drive assembly transfers power from the gasoline engine to the displacement pump.

Displacement Pump

The positive-displacement, volume-balanced pump provides equal fluid delivery on both the up and down pump strokes. The pump has a wetcup which, when filled with Graco Throat Seal Liquid, helps prevent damage to the throat packings and piston rod.

Fluid Filter

The fluid filter strains the paint to help avoid clogs in the hose and spray tip. The filter includes a reusable element, and a pressure drain valve for relieving fluid pressure.

Hoses

The grounded, nylon spray hoses have spring guards on both ends. The 50 ft. (15.2 m) hose has a 1/4 in. ID. The 3 ft. (0.9 m), 3/16 in. ID whip hose provides more flexible gun movement. The nylon hose material acts as a pulsation dampener to absorb pressure fluctuations.

Spray Gun & RAC™ IV DripLess™ Tip Guard

Graco high pressure spray guns have a trigger safety which prevents accidental triggering when the safety is engaged. See Fig. 1. The gun provided with the sprayer also has a filter for final paint straining. The Reverse-A-Clean™ IV (RAC IV) SwitchTip™ uses high pressure fluid to remove clogs from the spray tip without removing the spray tip from the gun. The Reverse-A-Clean™ IV DripLess™ tip guard is a safety feature which helps reduce the risk of a fluid injection injury.

WARNINGS

**High Pressure Spray Can Cause Serious Injury. For Professional Use Only.
Observe All Warnings. Read and understand all instruction manuals before operating equipment.**

FLUID INJECTION HAZARD

General Safety

This equipment generates very high fluid pressure. Spray from the gun, leaks or ruptured components can inject fluid through your skin and into your body, and cause extremely serious injury, including the need for amputation. Also, fluid injected or splashed into the eyes or on the skin can cause serious damage.

NEVER point the spray gun at any one or at any part of the body. NEVER put your hand or fingers over the spray tip. NEVER try to “blow back” paint; this is NOT an air spray system.

ALWAYS have the tip guard in place on the spray gun when spraying.

ALWAYS follow the **Pressure Relief Procedure**, below, before cleaning or removing the spray tip or servicing any system equipment.

NEVER try to stop or deflect leaks with your hand or body.

Be sure equipment safety devices are operating properly before each use.

Medical Alert—Airless Spray Wounds

If any fluid appears to penetrate your skin, get EMERGENCY MEDICAL CARE AT ONCE. DO NOT TREAT AS A SIMPLE CUT. Tell the doctor exactly what fluid was injected.

Note to Physician: Injection in the skin is a traumatic injury. It is important to treat the injury surgically as soon as possible. Do not delay treatment to research toxicity. Toxicity is a concern with some exotic coatings injected directly into the blood stream. Consultation with a plastic surgeon or reconstructive hand surgeon may be advisable.

Spray Gun Safety Devices

Be sure all gun safety devices are operating properly before each use. Do not remove or modify any part of the gun; this can cause a malfunction and result in serious injury.

Safety Latch

Whenever you stop spraying, even for a moment, always set the trigger safety latch in the closed or “safe” position, making the gun inoperative. Failure to set the safety latch can result in accidental triggering of the gun.

Diffuser

The gun diffuser breaks up spray and reduces the risk of fluid injection when the tip is not installed. Check diffuser operation regularly. Follow the **Pressure Relief Procedure**, below, then remove the spray tip. Aim the gun into a metal pail, holding the gun firmly to the pail. Using the lowest possible pressure, trigger the gun. If the fluid emitted is not diffused into an irregular stream, replace the diffuser immediately.

Tip Guard

ALWAYS have the tip guard in place on the spray gun while spraying. The tip guard alerts you to the fluid injection hazard and helps reduce, but does not prevent, the risk of accidentally placing your fingers or any part of your body close to the spray tip.

Trigger Guard

Always have the trigger guard in place on the gun when spraying to reduce the risk of accidentally triggering the gun if it is dropped or bumped.

Spray Tip Safety

Use extreme caution when cleaning or changing spray tips. If the spray tip clogs while spraying, engage the trigger safety latch immediately. ALWAYS follow the **Pressure Relief Procedure**, below, and then remove the spray tip to clean it.

NEVER wipe off build-up around the spray tip until the pressure is fully relieved and the gun safety is engaged.

PRESSURE RELIEF PROCEDURE

To reduce the risk of serious injury, including fluid injection, splashing fluid or solvent in the eyes or on the skin, or injury from moving parts or electric shock, always follow this procedure whenever you shut off the sprayer, when checking or servicing any part of the spray system, when installing, cleaning or changing spray tips, and whenever you stop spraying.

- 1 Engage the trigger safety latch.
- 2 Turn the engine ON/OFF switch to OFF.
- 3 Flip the pressure control switch to OFF.
- 4 Disengage the trigger safety latch. Hold a metal part of the gun firmly to the side of a grounded metal pail, and trigger the gun to relieve pressure.

- 5 Engage the trigger safety latch.
- 6 Open the pressure drain valve. Leave the valve open until you are ready to spray again.
- 7 Disconnect the spark plug cable.

If you suspect that the spray tip or hose is completely clogged, or that pressure has not been fully relieved after following the steps above, VERY SLOWLY loosen the tip guard retaining nut or hose end coupling to relieve pressure gradually, then loosen completely. Now clear the tip or hose.

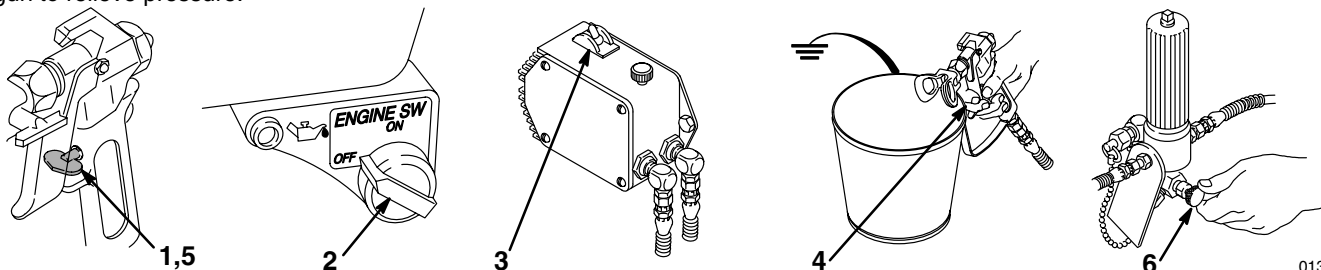

0139

MOVING PARTS HAZARD

Moving parts can pinch or amputate your fingers or other body parts. KEEP CLEAR of moving parts when starting or operating the sprayer. Follow the **Pressure Relief Procedure** above before

checking or servicing any part of the sprayer, to prevent it from starting accidentally.

EQUIPMENT MISUSE HAZARD

General Safety

Any misuse of the spray equipment or accessories, such as overpressurizing, modifying parts, using incompatible chemicals and fluids, or using worn or damaged parts, can cause them to rupture and result in fluid injection, splashing in eyes or on skin, or other serious injury, or fire, explosion or property damage.

NEVER alter or modify any part of this equipment; doing so could cause it to malfunction.

CHECK all spray equipment regularly and repair or replace worn or damaged parts immediately.

Always wear protective eyewear, gloves, clothing and respirator as recommended by the fluid and solvent manufacturer.

Noise

Ear protection is recommended when the sprayer is operating. Refer to the Sound Level in the **Technical Data** on page 43.

System Pressure

This sprayer can develop 3000 psi (210 bar) *Maximum Working Pressure*. Be sure all spray equipment and accessories used are rated to withstand this pressure. DO NOT exceed the maximum working pressure of any component or accessory used in the system.

Fluid and Solvent Compatibility

All chemicals used in the sprayer must be chemically compatible with the wetted parts shown in the **Technical Data** on page 43. Consult your chemical supplier to ensure compatibility.

Do not use 1,1,1-trichloroethane, methylene chloride, other halogenated hydrocarbon solvents or fluids containing such solvents in this equipment, which contains aluminum and/or zinc parts. Such use could result in a serious chemical reaction, with the possibility of explosion, which could cause death, serious injury and/or substantial property damage.

HOSE SAFETY

High pressure fluid in the hoses can be very dangerous. If the hose develops a leak, split or rupture due to any kind of wear, damage or misuse, the high pressure spray emitted from it can cause a fluid injection injury or other serious injury or property damage.

All fluid hoses must have strain reliefs on both ends! The strain reliefs help protect the hose from kinks or bends at or close to the coupling which can result in hose rupture.

TIGHTEN all fluid connections securely before each use. High pressure fluid can dislodge a loose coupling or allow high pressure spray to be emitted from the coupling.

NEVER use a damaged hose. Before each use, check the entire hose for cuts, leaks, abrasion, bulging cover, or damage or movement of the hose couplings. If any of these conditions exist, replace the hose immediately. DO NOT try to recouple high pressure hose or mend it with tape or any other device. A repaired hose cannot contain the high pressure fluid.

Handle and route hoses carefully. Do not pull on hoses to move equipment. Keep hoses clear of moving parts and hot surfaces of the pump and gas engine. Do not use fluids or solvents which are not compatible with the inner tube and cover of the hose. DO NOT expose Graco hoses to temperatures above 180° F (82° C) or below -40° F (-40° C).

Hose Grounding Continuity

Proper hose grounding continuity is essential to maintaining a grounded spray system. Check the electrical resistance of your fluid hoses at least once a week. If your hose does not have a tag on it which specifies the maximum electrical resistance, contact the hose supplier or manufacturer for the maximum resistance limits. Use a resistance meter in the appropriate range for your hose to check the resistance. If the resistance exceeds the recommended limits, replace it immediately. An ungrounded or poorly grounded hose can make your system hazardous. Also read **Fire Or Explosion Hazard**, below.

FLUID INJECTION HAZARD

Static electricity is created by the flow of fluid through the pump and hose. If every part of the spray equipment is not properly grounded, sparking may occur, and the system may become hazardous. Sparking may also occur when plugging in or unplugging a power supply cord or using a gasoline engine. Sparks can ignite fumes from solvents and the fluid being sprayed, dust particles and other flammable substances, whether you are spraying indoors or outdoors, and can cause a fire or explosion and serious injury and property damage.

If you experience any static sparking or even a slight shock while using this equipment, STOP SPRAYING IMMEDIATELY. Check the entire system for proper grounding. Do not use the system again until the problem has been identified and corrected.

Grounding

To reduce the risk of static sparking, ground the sprayer and all other spray equipment used or located in the spray area. CHECK your local electrical code for detailed grounding instructions for your area and type of equipment. BE SURE to ground all of this spray equipment:

1. *Sprayer*: connect a ground wire and clamp (supplied) to a true earth ground.

2. *Fluid hoses*: use only grounded hoses with a maximum of 500 ft (150 m) combined hose length to ensure grounding continuity. See **Hose Grounding Continuity**, above.
3. *Spray gun*: obtain grounding through connection to a properly grounded fluid hose and sprayer.
4. *Object being sprayed*: according to local code.
5. *Fluid supply container*: according to local code.
6. *All solvent pails used when flushing*, according to local code. Use only metal pails, which are conductive. Do not place the pail on a non-conductive surface, such as paper or cardboard, which interrupts the grounding continuity.
7. *To maintain grounding continuity when flushing or relieving pressure*, always hold a metal part of the gun firmly to the side of a grounded metal pail, then trigger the gun.

Flushing Safety

Reduce the risk of fluid injection injury, static sparking, or splashing by following the flushing procedure given on page 15 of this manual. Follow the **Pressure Relief Procedure** on page 4, and remove the spray tip before flushing. Hold a metal part of the gun firmly to the side of a grounded metal pail and use the lowest possible fluid pressure during flushing.

GASOLINE ENGINE HAZARD

NEVER fill the fuel tank while the engine is running or hot. Fuel spilled on a hot surface can ignite and cause a fire.

ALWAYS pour fuel in slowly to avoid spilling. Also read **Fire Or Explosion Hazard**, above, and **Fueling** on page 11.

NEVER operate the engine in a closed building unless the engine exhaust is piped outside. The exhaust contains carbon monoxide, a poisonous, odorless and invisible gas which can cause serious illness and even death of inhaled.

IMPORTANT

United States Government safety standards have been adopted under the Occupational Safety and Health Act. These standards – particularly the General Standards, Part 1910, and the Construction Standards, Part 1926 – should be consulted.

Avertissement

**La pulvérisation à haute pression peut causer des blessures très graves.
Réservé exclusivement à l'usage professionnel. Observer toutes les consignes de sécurité.
Bien lire et bien comprendre tous les manuels d'instructions avant d'utiliser le matériel.**

RISQUES D'INJECTION

Consignes générales de sécurité

Cet appareil produit un fluide à très haute pression. Le fluide pulvérisé par le pistolet ou le fluide sous pression provenant de fuites ou de ruptures peut pénétrer sous la peau ou à l'intérieur du corps et entraîner des blessures très graves, voir même une amputation. Même sans être sous pression, le fluide éblouissant ou entrant dans les yeux peut aussi entraîner des blessures graves.

Ne jamais pointer le pistolet vers quelqu'un ou vers une partie quelconque du corps. **Ne jamais** mettre le main ou les doigts sur l'ajutage du pulvérisateur. **Ne jamais** essayer de "refouler" la peinture. Cet appareil N'est PAS un compresseur pneumatique.

TOUJOURS garder la protection de l'ajutage en place sur le pistolet pendant la pulvérisation.

TOUJOURS observer la **Marche à Suivre Pour Détendre la Pression** donnée plus loin, **avant** de nettoyer ou d'enlever l'ajutage du pulvérisateur, ou d'effectuer un travail quelconque sur une partie de l'appareil.

NE JAMAIS essayer d'arrêter ou de dévier les fuites avec la main ou le corps.

Avant chaque utilisation, bien s'assurer que les dispositifs de sécurité fonctionnent correctement.

Soins médicaux

En cas de pénétration de fluide sous la peau: **DEMANDER IMMEDIATEMENT DES SOINS MÉDICAUX D'URGENCE.** Ne pas soigner cette blessure comme une simple coupure.

Avis au médecin: *La pénétration des fluides sous la peau est un traumatisme. Il est important de traiter chirurgicalement cette blessure immédiatement. Ne pas retarder le traitement pour effectuer des recherches sur la toxicité. Certains revêtements exotiques sont dangereusement toxiques quand ils sont injectés directement dans le sang. Il est souhaitable de consulter un chirurgien esthétiques ou un chirurgien spécialisé dans la reconstruction des mains.*

Dispositifs de sécurité du pistolet

Avant chaque utilisation, bien s'assurer que tous les dispositifs de sécurité du pistolet fonctionnent correctement. Ne pas enlever ni modifier une partie quelconque du pistolet; ceci risquerait d'entraîner un mauvais fonctionnement et des blessures graves.

Verrou de sécurité

A chaque fois que l'on s'arrête de pulvériser, même s'il s'agit d'un court instant, toujours mettre le verrou de sécurité du pistolet sur la position, "fermée" ou "sécurité" ("safe"), pour empêcher le pistolet de fonctionner. Si le verrou de sécurité n'est pas mis, le pistolet peut se déclencher accidentellement.

Diffuseur

Le diffuseur du pistolet sert à diviser le jet et à réduire les risques d'injection accidentelle quand l'ajutage n'est pas en place. Vérifier le fonctionnement du diffuseur régulièrement. Pour cette vérification, détendre la pression en observant la Marche à Suivre Pour Détendre la Pression donnée plus loin enlever l'ajutage du pulvérisateur. Pointer le pistolet dans un seau en métal, en le maintenant fermement contre le seau. Puis, en utilisant la pression la plus faible possible, appuyer sur la gâchette du pistolet. Si le fluide projeté n'est pas diffusé sous forme de jet irrégulier, remplacer immédiatement le diffuseur.

Protection de l'ajutage

TOUJOURS maintenir la protection de l'ajutage en place sur le pistolet du pulvérisateur pendant la pulvérisation. La protection de l'ajutage attire l'attention sur les risques d'injection et contribue à réduire, mais n'évite pas le risque, que les doigts ou une partie quelconque du corps ne passent accidentellement à proximité immédiate de l'ajutage du pulvérisateur.

Consignes de sécurité concernant l'ajutage du pulvérisateur

Faire extrêmement attention à l'occasion du nettoyage ou du remplacement des ajutages du pulvérisateur. Si l'ajutage se bouche pendant la pulvérisation, mettre immédiatement le verrou de sécurité du pistolet. TOUJOURS bien observer la Marche à Suivre Pour Détendre la Pression puis enlever l'ajutage du pulvérisateur pour le nettoyer.

NE JAMAIS essayer ce qui s'est accumulé autour de l'ajutage du pulvérisateur avant que la pression ne soit complètement tombée et que le verrou de sécurité du pistolet ne soit engagé.

MARCHE A SUIVRE POUR DÉTENDRE LA PRESSION

Pour réduire les risques de blessures graves, y compris les blessures par projection de fluide ou celles causées par de éclaboussures dans les yeux ou sur la peau, par des pièces en mouvement, toujours bien observer cette marche à suivre chaque fois que l'on arrête le pulvérisateur, à l'occasion de la vérification, du Égale ou du nettoyage du système ou lors du changement des ajutages.

1. Engager le verrou de sécurité du pistolet.
2. Mettre le levier d'arrêt du moteur sur ARRET (OFF).
3. Basculer l'interrupteur de commande de pression sur ARRET (OFF).
4. Désengager le verrou de sécurité du pistolet. Tout en maintenant une partie métallique du pistolet fermement appuyé contre le côté d'un seau en métal, actionner le pistolet pour libérer la pression.

5. Engager le verrou de sécurité du pistolet.
6. Ouvrir la soupape de sécurité et la laisser ouverte jusqu'à ce que l'on soit prêt à se servir de nouveau du pulvérisateur.
7. Débrancher le fil de la bougie.

*Si l'on soupçonne que le tuyau ou l'ajutage est complètement bouché ou que la pression n'a pas été complètement libérée après avoir procédé aux opérations ci-dessus, desserrer **Tres lentement** un raccord de bout de tuyau ou l'écrou de retenue de la protection de l'ajutage et libérer progressivement la pression.*

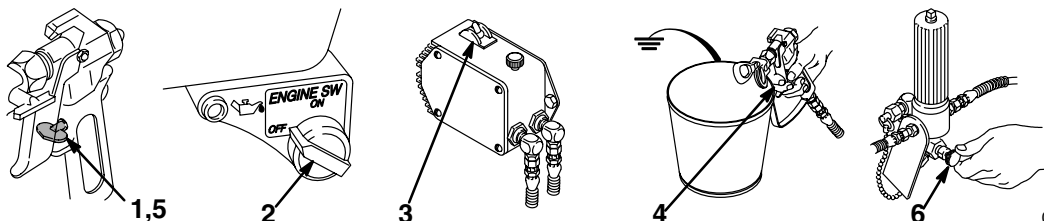

0139

RISQUES EN CAS DE MAUVAISE UTILISATION DU MATERIEL

Consignes générales de sécurité

Toute utilisation anormale de l'appareil de pulvérisation ou des accessoires comme, par exemple, la mise sous une pression excessive, les modifications de pièces, l'utilisation de produits chimiques et de matières incompatibles et l'utilisation de pièces usées ou abîmées peut causer des dégâts à l'appareil ou des ruptures de pièces et entraîner une injection de liquide ou d'autres blessures sérieuses, un incendie, une explosion ou d'autres dégâts.

Toujours porter une protection pour les yeux, de gants, des vêtements protecteur et un dispositif pour la respiration correspondant aux recommandations des fabricants de fluides et solvants.

Pression

Ce pulvérisateur peut produire une **PRESSION MAXIMUM DE TRAVAIL 210 bar (3000 lb/po. 2)** S'assurer que tous les éléments du pulvérisateur et ses accessoires sont conçus pour résister à la pression maximum de travail de ce pulvérisateur. NE PAS dépasser la pression maximum de travail d'aucun des éléments ou accessoires utilisés avec cet appareil.

Compatibilité chimique des corps

BIEN S'ASSURER que tous les corps des solvants utilisés sont chimiquement compatibles avec les parties mouillées indiquées dans les "Données techniques", à page 43. Toujours lire soigneusement les documents et brochures du fabricant des fluides et solvants utilisés avant de s'en servir dans ce pulvérisateur.

Le fluide à haute pression circulant dans les tuyaux peut être très dangereux. En cas de fuite sur le tuyau, de fissure, déchirure ou rupture à la suite de l'usure, de dégâts ou d'une mauvaise utilisation, les projections de fluide haute pression qui en proviennent peuvent entraîner des blessures graves par pénétration sous la peau ou par contact, ainsi que des dégâts matériels.

Tous les tuyaux flexibles doivent avoir des ressorts spirale de protection aux 2 bouts! Les spirales de protection contribuent à éviter la formation de pliures, de boucles ou de nœuds sur les tuyaux qui pourraient entraîner la rupture du tuyau à l'endroit du raccord ou à son voisinage.

Serrer fermement tous les raccords avant chaque utilisation. Le fluide sous pression peut faire sauter un raccord desserré ou produire un jet à haute pression s'échappant par le raccord.

NE JAMAIS utiliser un tuyau endommagé. NE PAS essayer de refaire le raccord d'un tuyau haute pression ni de réparer le tuyau avec du ruban adhésif ou par tout autre moyen. Un tuyau réparé ne peut pas résister au fluide sous pression.

Manipuler les tuyaux avec précaution et choisir soigneusement leur chemin. Ne pas déplacer le fluide en tirant sur le tuyau. Ne pas utiliser de fluides ou de solvants que ne sont pas compatibles avec l'enveloppe intérieur ou extérieure de tuyau. NE PAS exposer le tuyau à fluides des températures supérieures à 82°C (180°F) ou inférieures à -40°C (-40°F).

Continuité de la mise à la terre des tuyaux

Une bonne continuité de la mise à la terre des tuyaux est essentielle pour maintenir la mise à la terre de l'ensemble de vaporisation. Vérifiez la résistance électrique de vos tuyaux à fluides et à air, au moins une fois par semaine. Si votre tuyau ne comporte pas d'étiquette qui précise la résistance électrique maximum, prenez contact avec le fournisseur de tuyaux ou la fabricant pour avoir les limites de résistance maximum. Utilisez un mètre de résistance de la gamme appropriée pour votre tuyau et vérifiez la résistance. Si celle-ci dépasse les limites recommandées, remplacez le tuyau immédiatement. Un tuyau sans mise à la terre ou avec une mise à la terre incorrecte peut entraîner des risques pour votre système. Lisez aussi LES RISQUES D'INCENDIE OU D'EXPLOSION.

RISQUES D'INCENDIE OU D'EXPLOSION

De l'électricité statique est produite par le passage du fluide à grande vitesse dans la pompe et dans les tuyaux. Si toutes les pièces de l'appareil de pulvérisation ne sont pas convenablement reliées ou à la masse ou à la terre, des étincelles peuvent se produire et l'appareil risque d'être dangereux. Des étincelles peuvent également se produire à l'occasion du branchement ou du débranchement du cordon d'alimentation ou de l'utilisation d'un moteur à essence. Les étincelles sont suffisantes pour allumer les vapeurs de solvants et le fluide pulvérisé, les fines particules de poussière ainsi que d'autres substances inflammables, quand on pulvérisé à l'intérieur ou à l'extérieur, et elles peuvent causer un incendie ou une explosion, ainsi que des blessures graves et des dégâts matériels.

S'il se produit des étincelles d'électricité statique, ou si vous sentez la moindre décharge, **ARRETEZ IMMEDIATEMENT LA PULVERISATION**. Vérifiez que le système avant que le problème soit identifié et corrigé.

Mise à la terre ou à la masse

Pour réduire les risques de production d'étincelles d'électricité statique, le pulvérisateur et tous les équipement utilisés ou se trouvant dans la zone de pulvérisation doivent être reliés à la terre ou à la masse. Pour connaître le détail des instructions de mise à la terre dans la région et le type particulier d'équipement, CONSULTER le code ou les réglementations électriques locales. S'ASSURER que tous le équipements de pulvérisation suivants sont bien reliés à la terre:

- 1 *Pulvérisateur*: Relier le file de masses et le collier (fourni) à une bonne terre.

- 2 *Pistolet*: Réaliser la mise à la terre en le raccordant à un tuyau flexible et à un pulvérisateur déjà convenablement reliés à la terre.
- 3 *Tuyaux flexibles*: Afin d'assurer la continuité de la mise à la terre, n'utiliser que des tuyaux comportant une mise à la terre et ayant une longueur maximum combinée de 150 m (500 pieds). Se reporter également au paragraphe, "**Continuité du circuit de mis à la terre des tuyaux**".
- 4 *Réceptacle d'alimentation*: observer le code ou les réglementations locales.
- 5 *Objets, matériel ou surfaces recevant la pulvérisation*: observer le code ou les réglementations locales.
- 6 *Tous le seaux de solvant* utilisés pour le rinçage: observer le code ou les réglementations locales. *N'utiliser que des seaux métallique* conducteurs de l'électricité. Ne pas mettre le seau sur une surface non conductrice comme sur du papier ou du carton car cela interromprait la continuité de la mise à la terre.
- 7 *Pour conserver la continuité de la mise à la terre quand on rincé le matériel ou quand on libère la pression*, toujours maintenir une partie métallique du pistolet fermement appuyée contre le côté d'un seau *en métal* puis appuyer sur la détente du pistolet.

Mesures de Sécurité concernant le Rinçage

Pour réduire les risques de blessures par pénétration de la peau et les risques dûs aux étincelles d'électricité statique ou aux éclaboussures, observe la marche à suivre pour le rinçage donnée à la page 15 de ce manuel.

MESURES DE SECURITE CONCERNANT LES TUYAUX FLEXIBLES

NE JAMAIS remplir le réservoir de carburant quand le moteur tourne ou quand il est chaud. Le carburant renversé sur une surface chaude peut s'enflammer et causer un incendie. **TOUTJOURS** verse le carburant lentement pour éviter d'en renverser. Lire **RISQUES D'INCENDIE OU D'EXPLOSION**.

NE JAMAIS faire tourner un moteur dans un bâtiment fermé à moins que les gaz d'échappement ne soient dirigés au dehors. Les gaz d'échappement contiennent de l'oxyde de carbone, un gaz toxique, inodore et invisible qui peut entraîner des blessures graves ou même la mort se l'on ne respire.

ADVERTENCIA

EL ROCIADO a ALTA PRESIÓN PUEDE CAUSAR GRAVES LESIONES.
SOLO PARA USO PROFESIONAL. RESPETE LOS AVISOS DE ADVERTENCIA.
Lea y entienda todo el manual de instrucciones antes de manejar el equipo.

PELIGRO DE INYECCION DE FLUIDO

Seguridad general

Este equipo general un fluido a una presión muy alta. El rociado de la pistola, los escapes de fluido o roturas de los componentes pueden inyectar fluido en la piel y el cuerpo y causar lesiones extremadamente graves, incluyendo a veces la necesidad de amputación. También, el fluido inyectado o salpicado en los ojos puede causar graves daños.

NUNCA apuntar la pistola hacia alguien o alguna parte del cuerpo. NUNCA colocar la mano o los dedos encima de la boquilla. NUNCA tratar de "hacer retornar la pintura"; este NO es un sistema de rociado de aire.

SIEMPRE tener colocado el protector de la boquilla en la pistola mientras se está pulverizando.

SIEMPRE seguir el **procedimiento de descarga de presión**, dado más abajo, *antes* de limpiar o sacar la boquilla o de dar servicio a cualquier del sistema.

NUNCA tratar de parar o desviar los escapes con la mano o el cuerpo.

Asegurar que todos los aparatos de seguridad del equipo están funcionando bien antes de cada uso.

Tratamiento médico

Si pareciera que un poco de fluido penetró la piel, conseguir **TRATAMIENTO MEDICO DE URGENCIA DE INMEDIATO. NO TRATAR LA HERIDA COMO UN SIMPLE CORTE.** Decir al médico exactamente cual fluido fue.

Aviso al médico: Si se llega a inyectar este fluido en la piel se causa una lesión traumática. Es importante tratar quirúrgicamente la lesión a la brevedad posible. No demorar el tratamiento para investigar la toxicidad. La toxicidad es algo de sumar importancia en algunas pinturas exóticas cuando se inyectan directamente al torrente sanguíneo. Sirá conveniente consultar a un especialista en cirugía plástica o reconstructiva de las manos.

Aparatos de seguridad de la pistola pulverizadora

Asegurar que todos los aparatos protectores de la pistola están funcionando bien antes de cada uso. No sacar ni modificar ninguna pieza de la pistola pues podría causar el malfuncionamiento de la misma con las consiguientes lesiones personales.

Pestillo de seguridad

Cada vez que se deje de pulverizar, aunque sea por un breve momento, siempre colocar el pestillo de seguridad en la posición "cerrada", lo que deja la pistola inoperante. El no hacerlo puede llevar al disparo imprevisto de la pistola.

Difusor

El difusor de la pistola dispersa el chorro pulverizado y reduce el riesgo de inyección cuando no está instalada la boquilla. Revisar con regularidad el funcionamiento del difusor. Seguir el procedimiento de descarga de presión, dado más abajo, y después sacar la boquilla. Apuntar la pistola a un balde metálico, sosteniéndola bien firme contra él. Utilizando la presión más bajo posible, disparar la pistola. Si el fluido emitido *no sale disperso* en un chorro irregular, reemplazar de inmediato el difusor.

Protector de la boquilla

SIEMPRE tener el protector de la boquilla colocado en la pistola mientras se está pulverizando. Este protector llama la atención contra el peligro de inyección y ayuda a reducir, pero no evita, la colocación accidental de los dedos o cualquier otra parte del cuerpo cerca de la boquilla.

Seguridad de la boquilla pulverizadora

Tener mucho cuidado al limpiar o cambiar las boquillas. Si llegara a obstruirse mientras está pulverizando, enganchar el pestillo de la pistola de inmediato. SIEMPRE seguir el procedimiento de descarga de presión y después sacar la boquilla para limpiarla

NUNCA limpiar la acumulación de pintura alrededor de la boquilla antes de que se haya descargado por completo la presión y el pestillo esté enganchado.

PROCEDIMIENTO DE DESCARGA DE PRESION

Para reducir el riesgo de sufrir graves lesiones corporales, incluyendo la inyección de fluidos, salpicaduras en los ojos o la piel, o lesiones causadas por piezas en movimiento, siempre seguir este procedimiento al apagar la máquina pulverizadora, al revisar, ajustar o limpiar el sistema, o al cambiar las boquillas.

- 1 Enganchar el pestillo de seguridad de la pistola.
- 2 Mover el interruptor de parada del motor a OFF.
- 3 Mover el interruptor de control de presión a OFF.
- 4 Desenganchar el pestillo de seguridad de la pistola. Mantener una parte metálica de la pistola firmemente contra el lado de un balde de metal y activar la pistola para descargar la presión.

- 5 Volver a enganchar el pestillo de seguridad de la pistola.
- 6 Abrir la válvula de alivio de presión y dejarla abierta hasta que se esté nuevamente listo para pulverizar.
- 7 Desconectar el cable de la bujía.

Si se sospecha que la boquilla o la manguera esté completamente obstruida, o que no se ha descargado por completo la presión después de haber seguido el procedimiento anterior, aflojar MUY LENTAMENTE un adaptador de extremo de la manguera o la tuerca de renovación del protector de la punta y descargar gradualmente la presión.

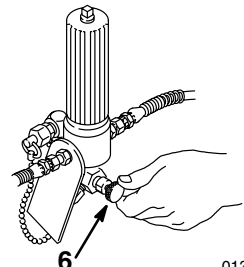
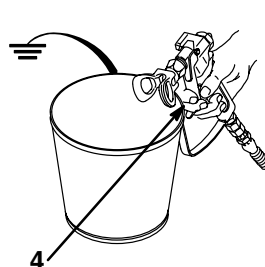
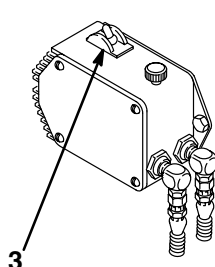
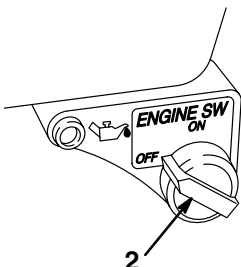
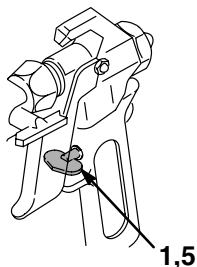

PELIGRO POR MAL USO DEL EQUIPO

Seguridad general

Cualquier mal uso del equipo pulverizador o los accesorios, tal como sobre presurización, modificación de piezas, uso de materiales y productos químicos incompatibles, o utilización de piezas dañadas o desgastadas, puede hacer que se rompan y causen la inyección de fluido u otras lesiones corporales graves, incendio, explosión o daños a la propiedad.

Siempre usar gafas, guantes, vestimentas protectoras y un respiradero, tal como recomiendan los fabricantes del fluido y del solvente.

Presión del sistema

Esta pulverizadora puede desarrollar 210 barías (3000 psi) de *PRESION DE TRABAJO MAXIMA*. Asegurar que todo el equipo pulverizador y sus accesorios tienen la capacidad para aguantar la presión máxima de trabajo de ningún componente o accesorio de este sistema.

Compatibilidad de fluido

Siempre leer las instrucciones del fabricante del fluido y solvente antes de usarlos en esta pulverizadora en la página 43.

SEGURIDAD EN EL USO DE LAS MANGUERAS

El fluido que escapa a alta presión por las mangueras puede ser muy peligroso. Si en la manguera se desarrolla un escape, una rotura o rajadura debido a cualquier tipo de desgaste, daño o maltrato, el chorro a alta presión emitido por allí puede causar una lesión por inyección u otras lesiones corporales graves o daños a la propiedad.

¡Todas las mangueras para fluidos tienen que tener guardas de resorte en ambos extremos! Estas protegen las mangueras contra dobleces o retorceduras en los acoplamientos o cerca de ellos, los que podrían traducirse en roturas de la manguera.

Antes de usarlas, APRETAR bien firmes todas las conexiones. El fluido a alta presión puede desalojar un acoplamiento suelto o dejar que por él escape un chorro a alta presión.

NUNCA usar una manguera que está dañada. Siempre revisarla en busca de cortaduras, escapes, abrasión, cubierta abultada, o acoplamientos sueltos o dañados. Si llegara a encontrarse cualquiera de estas condiciones, reemplazar de inmediato la manguera. NO intentar reacoplar una manguera de alta presión o enmendarla con cinta adhesiva u otro material similar. Una manguera que ha sido remendada no aguante el fluido al alta presión.

Manejar y pasar cuidadosamente las mangueras. No tirar de las mangueras para mover el equipo. No usar fluidos o solventes que sean incompatibles con el tubo interno y la cubierta de la manguera. NO exponer las mangueras a temperaturas sobre 82^o C (180°F) o bajo -40°C (-40° F).

Continuidad del circuito de puesta a tierra de la manguera

La continuidad del circuito de puesta a tierra apropiado es esencial para mantener conectado a tierra el sistema pulverizador. Es indispensable revisar la resistencia eléctrica máxima de las mangueras de aire y de fluido por lo menos una vez a la semana. Si la manguera no tiene una etiqueta en la cual se especifica la resistencia eléctrica máxima, ponerse en contacto con el proveedor o fabricante de la manguera para la información sobre los límites de resistencia. Usar un metro de resistencia en la gama apropiada para comprobar la resistencia; si excede los lites recomendados, reemplazarla de inmediato. Es muy arriesgado tener una manguera sin puesta a tierra o con la puesta a tierra en malas condiciones. Leer también la información sobre RIESGO DE INCENDIO O EXPLOSION, más arriba.

PELIGRO DE INCENDIO O EXPLOSION

El flujo a alta velocidad del fluido al pasar por la bomba y manguera crea electricidad estática. Si todas las partes del equipo pulverizador no tienen buena tierra, pueden ocurrir chispas, convirtiéndolo al sistema en algo peligroso. También, pueden producirse chispas al enchufar o desenchufar el cordón eléctrico o al usar un motor de gasolina. Estas chispas pueden inflamar los vapores de los solventes y el chorro de fluido pulverizado, partículas de polvo y otras sustancias inflamables, sea al aire libre o bajo techo, lo que podría causar una explosión o incendio y graves lesiones corporales y daños a la propiedad.

Si ocurre una chispa de electricidad estática o incluso un ligero choque eléctrico mientras se usa el equipo, DEJAR DE PULVERIZAR DE INMEDIATO. Revisar todo el sistema en busca de una tierra apropiado. No usar de nuevo el sistema hasta haber identificado y solucionado el problema.

Puesta a tierra

Para reducir el riesgo de chispas estáticas, conectar a tierra la pulverizadora y todo el otro equipo de pulverizar que se use o se encuentre en el lugar que se va a rociar. CONSULTAR el código eléctrico de la localidad para las instrucciones sobre las conexiones a tierra exigidas para la zona y tipo de equipo. ASEGURAR de conectar a tierra todo este equipo pulverizador:

- 1 *Pulverizadora*: Conectar el alambre de tierra y la abrazadera (suministrada) a una buena conexión a tierra.

- 2 *Mangueras para fluidos*: usar solamente mangueras con puesta a tierra de una longitud combinada de 150 m (500 pies), para asegurar buena continuidad a tierra. Referirse también al párrafo sobre continuidad a tierra de la manguera.
- 3 *Pistola*: hacer la puesta a tierra conectándola a una manguera de fluido y pulverizadora bien conectadas a tierra.
- 4 *Suministrar un recipiente*: de acuerdo al código local. Usar *solamente baldes de metal*, que sean conductivos. No colocar el balde en una superficie no conductiva, como papel o cartón, que interrumpe la continuidad a tierra.
- 5 *Objeto que se está rociando*: de conformidad con el código local.
- 6 *Todos los baldes de solvente* usados durante el lavado, de conformidad con el código local.
- 7 *Para mantener la continuidad a tierra durante el lavado o descarga de presión*, siempre apoyar una parte metálica de la pistola bien firme contra el costado de *balde de metal*, después apretar el gatillo.

Seguridad durante el lavado

Para reducir el riesgo de que se inyecte o salpique fluido en la piel, o que ocurra una descarga de electricidad estática, siempre seguir las INSTRUCCIONES PARA EL LAVADO, dadas en la página 15. Seguir el procedimiento de descarga de presión en la página 8, y quitar la *boquilla de metal* y usar la presión más baja posible de fluido durante el lavado.

PRECAUCIONES PARA LOS MOTORES DE GASOLINA

NUNCA llenar el tanque de combustible mientras el motor está funcionando o caliente. El combustible derramado en una superficie caliente puede encenderse y provocar un incendio. SIEMPRE verter el combustible lentamente para evitar derrames. Leer PELIGRO DE INCENDIO O EXPLOSION.

NUNCA hacer funcionar el motor en un edificio cerrado sin encaminar los gases de escape hacia el aire libre. Los gases de escape contienen monóxido de carbono, un gas venenoso, sin olor e invisible que podría causar enfermedades graves, incluso la muerte, al inhalarse.

Setup

1. **Connect hose and gun.** (Refer to Fig. 2.)
 - a. Remove the plastic cap plug from the filter outlet nipple (57) and screw the 50 ft. (15.2 m) main fluid hose (202) onto the nipple.
 - b. Connect the whip end hose (203) between the main fluid hose and the gun (204) inlet adapter.
 - c. **DO NOT** use thread sealant, and **DO NOT** install the spray tip yet!

WARNING

If you are supplying your own hoses and spray gun, be sure the hoses are electrically conductive, that the gun has a tip guard, and that each part is rated for at least *3000 psi (210 bar) Maximum Working Pressure*. This is to reduce the risk of serious injury caused by static sparking, fluid injection or over-pressurization and rupture of the hose or gun.

2. **Two gun hookup.** (Refer to Fig. 2.) Remove the cap (56) from the secondary hose outlet and attach an accessory hose and gun to the 1/4 npsm(m) nipple.

CAUTION

To avoid damaging the pressure control, which may result in poor equipment performance and component damage, follow these precautions.

1. Always use nylon spray hose at least 50 ft. (15.2 m) long.
 2. Never use a wire braid hose; it is too rigid to act as a pulsation dampener.
 3. Never install any shutoff device between the filter (51) and the main hose (202). See Fig. 2.
 4. Always use the main filter outlet (57) for one gun operation. Never plug this outlet.
3. **Fill packing nut/wetcup.** (See Fig. 2.) Fill the packing nut/wetcup (416) 1/3 full with Graco Throat Seal Liquid (TSL), supplied.
 4. **Check the engine oil level.** Refer to the Honda engine manual, supplied. This is a summary of the information: Remove one of the oil fill plugs; the oil should be almost overflowing. See Fig. 3. Add oil as necessary.

Recommended lubrication oil: Use a high-quality , detergent oil, SAE 10W-40, classified "FOR SERVICE SE or SF", for regular use and for breaking-in a new engine.

KEY

- 53 Pressure drain valve
- 56 Secondary hose cap
- 57 Outlet nipple
- 71 Pail hanger
- 202 Main hose
- 203 Whip end hose
- 204 "Contractor" gun with RAC IV Dripless tip guard and 517 size SwitchTip
- 416 Wetcup

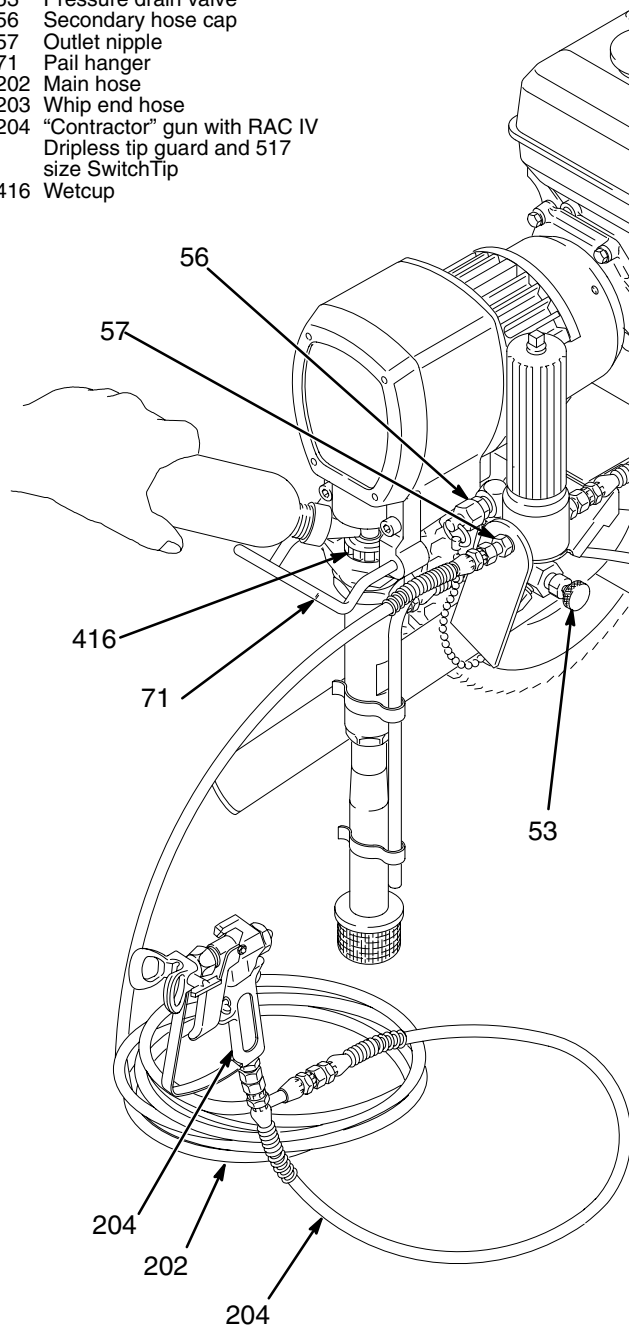

Fig. 2

0140

Setup

5. **Be sure your system is properly grounded before operating it.** Read and follow the warning section, **FIRE OR EXPLOSION HAZARD**, on page 5.
6. **Fill the gas tank.** See the **Fueling** section, below.
7. **Flush the pump** to remove the lightweight oil which was left in the pump to protect it from rust.
 - a. Before using water–base paint, flush with mineral spirits, followed by soapy water, and then flush with clean water.
 - b. Before using oil–base paint, flush with mineral spirits, only.
 - c. See **Flushing** on page 15 for the flushing procedure.
8. **Prepare the paint** according to the manufacturer's recommendations.
 - a. Remove any skin that may have formed.
 - b. Stir the paint to mix pigments.
 - c. Strain the paint through a fine nylon mesh bag (available at most paint dealers) to remove particles that could clog the filter or spray tip. This is probably the most important step toward trouble–free spraying.
9. **Keep the sprayer upright and level** during operation and whenever it is being moved. See the last **CAUTION** on page 12.

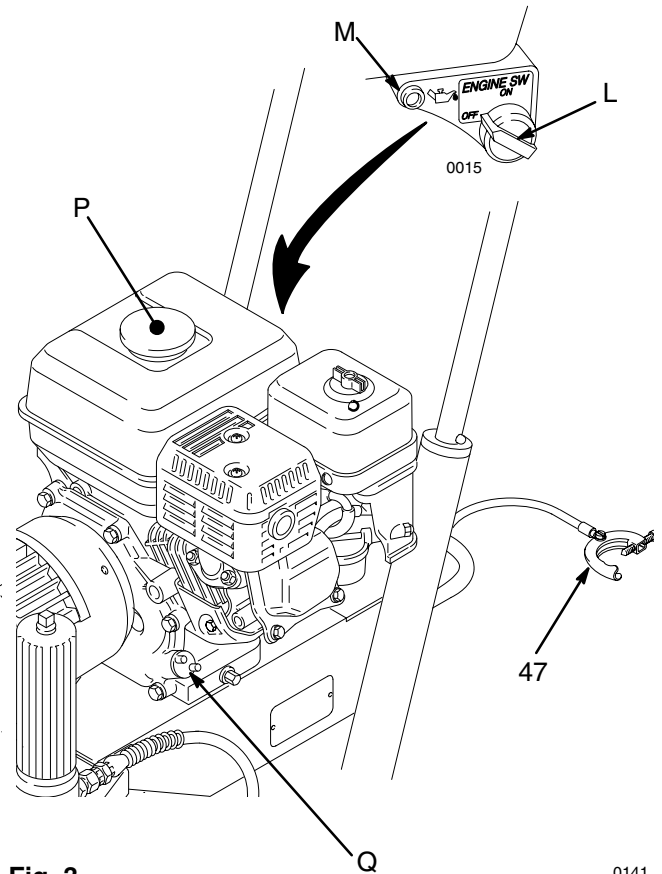

Fig. 3

0141

Fueling

WARNING

Gasoline is extremely flammable and explosive under certain conditions.

Always shut off the engine before refueling.

Refuel in a well–ventilated area.

Do not smoke or allow flames or sparks in the area where the engine is refueled or where the gasoline is stored.

Do not overfill the tank. Make sure the gas fill cap is securely closed after refueling.

Be careful not to spill fuel when fueling. Fuel vapor or spilled fuel can ignite. If any fuel is spilled, make sure the area is dry before starting the engine.

1. **Fuel specifications.** Use automotive gasoline with a pump octane number $[(R + M)/2]$ of 86 or higher, or a research octane number of 91 or higher. Unleaded fuel minimizes combustion chamber deposits.

2. **Gasolines containing alcohol (gasohol).** Do not use gasohol which contains methanol, if the gasohol does not contain cosolvents and corrosion inhibitors for methanol. Even if it does contain such additives, do not use the gasohol if it contains more than 5% methanol.

NOTE: The HONDA engine warranty does not cover damage resulting from the use of gasolines containing alcohol. See the HONDA engine manual for more information.

3. **General.** Do not use oil and gasoline mixtures or contaminated gasoline. A void getting dirt, dust or water in the fuel tank.
4. **Tank Capacity.** 0.95 gallons (3.6 liter). Always leave at least 1/2 in. at the top of the tank for expansion.
5. **Shut off the engine before refueling.**
6. **After refueling, tighten the fuel tank cap firmly.**

Startup

Before you start the sprayer

1. **See Flushing** on page 15 to determine if you should flush the sprayer.
2. **Be sure the gas tank is full.**
3. **Check the engine oil level.**

NOTE: The engine stops automatically, or will not start, if it is low on oil. If you try to start it again without adding more oil, a red light near the engine on/off switch glows as you pull the starter rope.

4. **Be sure the spark plug cable (G) is firmly pushed onto the plug.**

Startup

NOTE: Refer to Fig. 4 as you start the sprayer.

1. **When starting a sprayer that IS NOT PRIMED**, remove the spray tip.
2. **If a secondary hose and gun is not installed**, be sure the cap (56) is securely plugging the secondary outlet fitting.
3. **Place the suction tube into the paint, water or solvent container**, depending on whether you are flushing or are ready to spray.
4. **Open the black fuel shutoff lever (H)** by pushing it in the direction of the arrow.

CAUTION

Never try to start the engine unless fluid pressure is relieved and the pressure control switch (A) is OFF. Trying to start the engine when it is pressurized could damage the recoil system.

5. **Turn the pressure control switch (A) to OFF.**
6. **To start the engine:**
 - a. Turn the pressure adjusting knob (B) fully counterclockwise to the lowest pressure setting.
 - b. Slide the metal throttle lever (K) away from the fuel tank to maximum position (fully left).
 - c. If the engine is cold, close the choke by moving the gray lever (J).

If the engine is warm, close the choke by moving the gray lever only half way or not at all.
 - d. Turn the engine switch (L) to ON.

WARNING

A rope which recoils too quickly may hit someone and cause serious injury. The rope could also jam in recoil assembly.

- e. Hold the frame of the sprayer with one hand and pull the starter rope rapidly and firmly. Continue holding the rope as you let it return. Pull and return the rope until the engine starts.

- f. Open the choke as soon as the engine starts, except in cold weather. In cold weather, leave the choke closed for 10 to 30 seconds before opening it to keep the engine running.

7. **Disengage the trigger safety latch (N).**

8. **To start the pump:**

- a. Open the pressure drain valve (53).
- b. Turn the pressure control switch (A) to ON.
- c. Turn the pressure control knob (B) about 1/4 turn from minimum pressure. Run the pump until fluid is flowing smoothly from the pressure drain valve, indicating the pump is fully primed.
- d. Close the pressure drain valve (53). Hold a metal part of the gun firmly against a grounded metal pail and squeeze the trigger until fluid flows from the gun.
- e. Release the trigger. Engage the trigger safety latch (N).

9. **If you have not primed the sprayer with paint yet**, move the suction tube to the paint container. Release the trigger safety latch. Trigger the gun into the water/solvent pail just until paint appears. Release the trigger and engage the trigger safety latch. Repeat for the second gun if two guns are used.

WARNING

To reduce the risk of serious injury from fluid injection, NEVER operate the spray gun with the tip guard removed.

10. **Install the spray tip in the gun.** See the separate tip instruction manual, 307-848, supplied.
11. **Adjust the engine speed and pump pressure.** Release the trigger safety latch (N). Trigger the gun onto test paper to check the spray pattern and atomization. Turn the pressure adjusting knob (B) until you get a good pattern. Then slowly lower the throttle (K) setting as far as you can without changing the spray pattern.

CAUTION

Always use the lowest needed fluid pressure and the lowest needed throttle setting, to increase the life of the sprayer. Higher settings cause excessive clutch cycling and premature tip and pump wear.

CAUTION

Close the black fuel shutoff lever (H) whenever you are transporting the sprayer to prevent fuel from flooding the engine.

Keep the sprayer upright and level when operating it and when transporting it. This prevents crankcase oil from leaking into the combustion chamber, which makes startup very difficult.

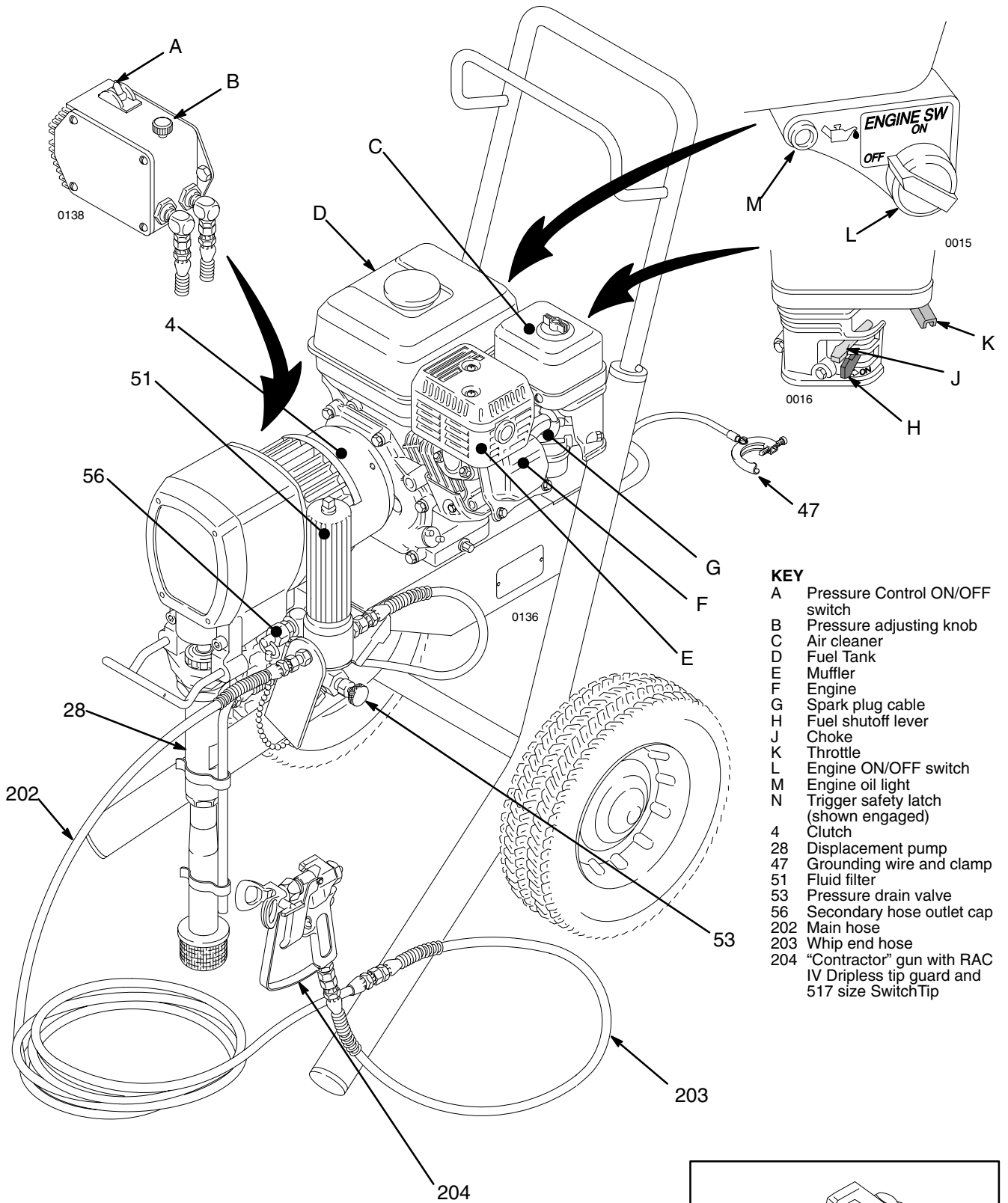

KEY

- A Pressure Control ON/OFF switch
- B Pressure adjusting knob
- C Air cleaner
- D Fuel Tank
- E Muffler
- F Engine
- G Spark plug cable
- H Fuel shutoff lever
- J Choke
- K Throttle
- L Engine ON/OFF switch
- M Engine oil light
- N Trigger safety latch (shown engaged)
- 4 Clutch
- 28 Displacement pump
- 47 Grounding wire and clamp
- 51 Fluid filter
- 53 Pressure drain valve
- 56 Secondary hose outlet cap
- 202 Main hose
- 203 Whip end hose
- 204 "Contractor" gun with RAC IV Dripless tip guard and 517 size SwitchTip

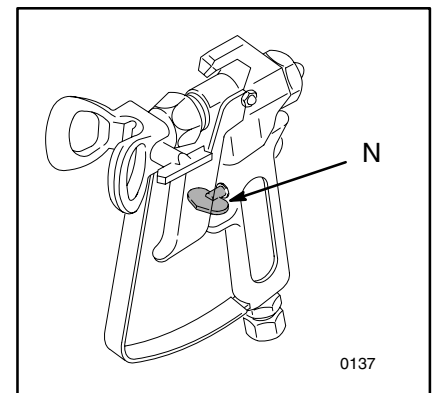

Fig. 4

Maintenance

WARNING

To reduce the risk of serious injury, including fluid injection or splashing in the eyes or on the skin, or injury from moving parts, always follow the **Pressure Relief Procedure Warning**, below, before checking, adjusting, cleaning or shutting down the sprayer. *Disconnect the spark plug!*

DAILY: Check the engine oil level and fill as necessary.

DAILY: Check and fill the gas tank.

AFTER THE FIRST 20 HOURS OF OPERATION

Drain the oil and refill with clean oil.

WEEKLY: Remove the cover of the air filter and clean the element. Replace the element, if necessary. If operating in an unusually dusty environment, check the filter daily and replace it, if necessary.

Replacement elements can be purchased from your local HONDA dealer.

CAUTION

For detailed engine maintenance and specifications, refer to the separate engine manual, supplied.

WEEKLY: Check the level of the TSL in the displacement pump packing nut. Fill the nut, if necessary. Keep TSL in the nut to help lubricate the pump packings.

AFTER EACH 100 HOURS OF OPERATION:

Change the oil.

SPARK PLUG: Use only an (NGK) BP6ES or BPR6ES plug. Gap the plug to 0.025 to 0.030 in. (0.7 to 0.8 mm). Use a spark plug wrench when installing and removing the plug.

WARNING

Pressure Relief Procedure

To reduce the risk of serious injury, including fluid injection, splashing fluid or solvent in the eyes or on the skin, or injury from moving parts or electric shock, always follow this procedure whenever you shut off the sprayer, when checking or servicing any part of the spray system, when installing, cleaning or changing spray tips, and whenever you stop spraying.

1. Engage the trigger safety latch.
2. Turn the engine ON/OFF switch to OFF.
3. Turn the pressure control switch to OFF.

4. Disengage the trigger safety latch. Hold a metal part of the gun firmly to the side of a grounded metal pail, and trigger the gun to relieve pressure.
5. Engage the trigger safety latch.
6. Open the pressure drain valve. Leave the valve open until you are ready to spray again.
7. Disconnect the spark plug cable.

If you suspect that the spray tip or hose is completely clogged, or that pressure has not been fully relieved after following the steps above, VERY SLOWLY loosen the tip guard retaining nut or hose end coupling to relieve pressure gradually, then loosen completely. Now clear the tip or hose.

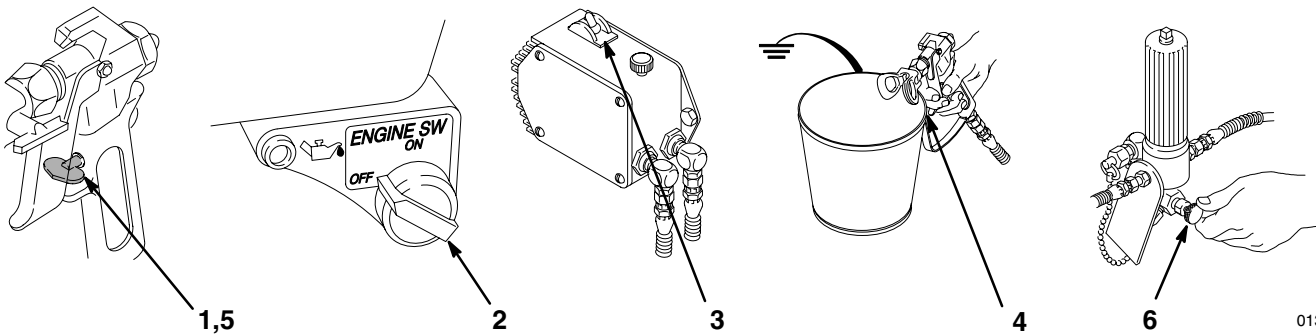

0139

Flushing

When to Flush

1. **New Sprayer.** This unit was factory tested in light-weight oil, which was left in to protect the pump.
Before using water-base paint, flush with mineral spirits, followed by a soapy water flush, and then a clean water flush.
Before using oil-base paint, flush with mineral spirits.
2. **Changing Colors.** Flush with a compatible solvent such as mineral spirits or water.
3. **Changing from water-base to oil-base paint.** Flush with warm, soapy water, then mineral spirits.
4. **Changing from oil-base to water-base paint.** Flush with mineral spirits, followed by warm, soapy water, and then a clean water flush.

CAUTION

NEVER leave water in the sprayer if there is the slightest chance it could freeze. Push the water out with mineral spirits. Water frozen in the pressure control tube prevents the sprayer from being started, and causes serious damage to the pressure control.

5. **Storage.**
Water base paint: flush with water, then mineral spirits and leave the pump, hose and gun filled with mineral spirits. Shut off the sprayer, remove the spark plug cable, and open the pressure drain valve to relieve pressure. Leave the drain valve open.
Oil base paint: flush with mineral spirits and leave the pump, hose and gun filled with mineral spirits. Shut off the sprayer, remove the spark plug cable, and open the pressure drain valve to relieve pressure. Leave the drain valve open.
6. **Startup after storage.**
Before using water-base paint, flush out mineral spirits with soapy water, and then with clean water.
When using oil-based paint, flush out the mineral spirits with the paint to be sprayed.

How to Flush

NOTE: "Solvent" refers to water or oil-based solvent.

1. Relieve pressure. See page 14.
2. Remove the filter bowl (R) and screen (S); see instruction manual 307-273, supplied. Install the bowl and support (T), without the screen, to flush. Clean the screen separately. See Fig. 5.
3. Close the pressure drain valve (53).
4. Put the suction tube in a grounded pail of solvent.
5. Remove the spray tip from the gun(s).

WARNING

To reduce the risk of static sparking and splashing when flushing, always remove the spray tip from the gun, and hold a metal part of the gun firmly to the side of, and aimed into, a grounded metal pail.

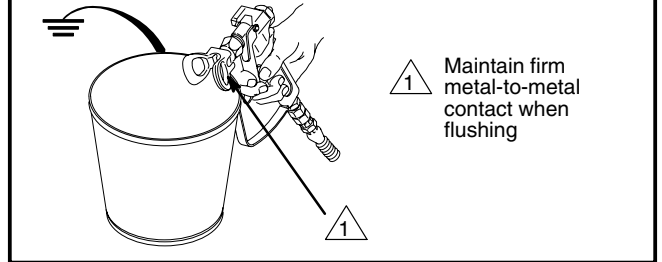

6. Follow **Startup** on page 12. Keep the gun triggered until clean solvent comes from the nozzle. Release the trigger and engage the trigger safety latch.

NOTE: For two guns, release the trigger safety latch on the second gun and trigger that gun until clean solvent comes from the nozzle. Flush the first gun and then the second gun at least one more time.

7. Check all fluid connections for leaks. Relieve pressure before tightening any connections. Start the sprayer. Recheck the connections for leaks.
8. Remove the suction tube from the solvent pail. Disengage the trigger safety latch. Trigger the gun to force solvent from the hose. Do not let the pump run dry for more than 30 seconds, to avoid damaging the pump packings. Relieve pressure.
9. Remove the strainer, suction tube and suction hose and clean them separately to be sure all paint sediment is removed. Dried paint can build up in these parts and later cause performance problems.
10. Unscrew the filter bowl and reinstall the clean screen. Reinstall the bowl, hand tight only.
11. Follow Storage or Changing Colors, to the left. Relieve pressure.

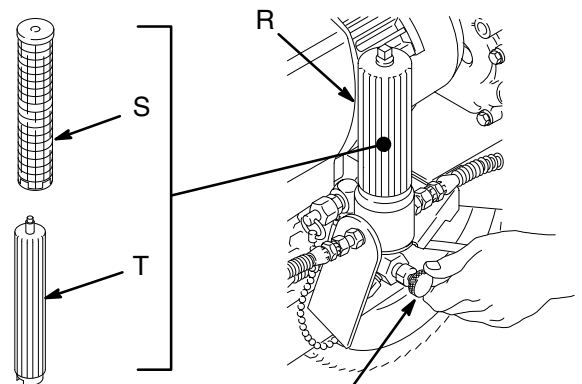

Fig. 5

53

0142

Troubleshooting Guide

WARNING

Pressure Relief Procedure

To reduce the risk of serious injury, including fluid injection, splashing in the eyes or on the skin, or injury from moving parts, always follow this procedure when you shut off the sprayer, when checking, adjusting or cleaning the system, and when changing spray tips.

Engage the trigger safety latch.

Turn the engine ON/OFF switch to OFF.

Turn the pressure control switch to OFF.

Disengage the trigger safety latch. Hold a metal part of the gun firmly to the side of a grounded metal pail, and trigger the gun.

Engage the trigger safety latch.

Open the fluid pressure drain valve and leave it open until you start the sprayer again.

Disconnect the spark plug.

*If you suspect the hose or spray tip is completely clogged or that pressure is not fully relieved after following the steps above, **VERY SLOWLY** loosen the tip guard or hose end coupling to relieve pressure gradually. Now clear the tip or hose obstruction.*

Check everything in the chart before disassembling the sprayer.

PROBLEM	CAUSE	SOLUTION
Engine/sprayer won't start	Engine switch not on	Turn on.
	Out of gas	Replenish
	Engine oil level low	Try starting engine. If light on rear of engine glows, replenish oil.
	Spark plug cable disconnected or spark plug damaged	Connect cable on top of engine or replace spark plug.
	Water frozen in pressure control	Return pressure control to authorized Graco dealer for repair.
Engine won't "pull over"	Oil seepage into combustion chamber	Remove spark plug. Pull starter rope 3 or 4 times. Clean or replace plug. Try to start. Keep sprayer upright to avoid oil seepage.
Engine operates, but displacement pump doesn't	Pressure control switch turned OFF	Turn on.
	Pressure setting too low	Increase pressure.
	Displacement pump outlet filter dirty	Clean filter.
	Tip or tip filter clogged	Clean tip or tip filter.
	Displacement pump rod seized by dry paint	Service pump. See page .
	Connecting rod worn or damaged	Replace. See page 18.
	Drive housing worn or damaged	Replace. See page 19.
	Electrical power not energizing field	Check wiring connections. See Fig. 13, page 23. With pressure control switch ON and pressure turned to MAXIMUM, use a test light to check for power at black and white wires from pressure control. Have pressure control checked by authorized Graco dealer.
	Clutch worn or damaged	Service. See page 22.
Pinion assembly worn or damaged	Service. See page 20.	

PROBLEM	CAUSE	SOLUTION
Displacement pump output low on upstroke	Pump inlet screen clogged	Clean.
	Piston ball check not seating	Service piston ball check. See page 31.
	Piston packings worn or damaged	Replace packings. See page 31.
	Sleeve gasket in displacement pump worn or damaged	Replace. See page 31.
Displacement pump output low on downstroke or both strokes	Pump inlet screen clogged	Clean.
	Piston packings worn or damaged	Replace packings. See page 31.
	Intake valve ball check not seating properly	Clean and service. See page 31.
	Engine RPM too low	Increase throttle setting. See Startup , Step 11, page 12.
	Clutch worn or damaged	Replace. See page 22.
Paint leaks into wet-cup	Loose wet-cup	Tighten just enough to stop leakage.
	Throat packings worn or damaged	Replace packings. See page 31.
	Displacement rod worn or damaged	Replace rod. See page 31.
Low fluid delivery	Pump inlet screen clogged.	Clean.
	Pressure setting too low	Increase pressure. See Startup , Step 11, page 12.
	Engine RPM too low	Increase throttle setting. See Startup , Step 11, page 12.
	Dirty outlet filter, tip filter or tip	Clean.
	Large pressure drop in hose	Use larger diameter hose.
Spitting from gun	Air in fluid pump or hose	Check for loose connections at pump intake and tighten. Then prime the pump. See page 12.
	Tip partially clogged	Clear.
	Fluid supply is low or empty	Refill and prime the pump. See Startup , page 12. Check fluid supply often to prevent running the pump dry.
Pump is difficult to prime	Air leak	Check all hose connections and tighten as needed. Reduce RPM and cycle pump as slowly as possible during priming.
	Intake valve is leaking	Shut off pump and relieve pressure. Disassemble and clean intake valve. Be sure ball seat is not nicked or worn and that the ball seats well. Reassemble.
	Worn packings	Repack the pump. See page 31.
	Fluid is too thick	Thin fluid according to supplier's recommendations.

Bearing Housing & Connecting Rod

WARNING

To reduce the risk of serious injury, including fluid injection always follow the **Pressure Relief Procedure Warning** on page 14 before checking, adjusting, cleaning or shutting off the sprayer. *Disconnect the spark plug!*

NOTE: Steps 1 to 13 refer to Fig. 6.

1. Remove the front cover and screws (23,68).
2. For upright models only: Remove the spring clips (112, 114) and the drain hose (113). Unscrew the suction tube (30) from the pump, holding a wrench on the pump intake valve (B) to keep the pump from loosening.
3. Disconnect the pump outlet hose (59) from the displacement pump outlet nipple (92).
4. Use a screwdriver to push aside the retaining spring (26) at the top of the pump. Push the pin (25) out the rear.
5. Loosen the jam nut (27) with an adjustable wrench. Unscrew and remove the displacement pump.
6. Use a hex key wrench to remove the four screws (73) and lockwashers (74) from the bearing housing (21).
7. While pulling the connecting rod (22) with one hand, lightly tap the lower rear of the bearing housing (21) with a plastic mallet to loosen it from the drive housing (20). Pull the bearing housing and the connecting rod assembly (22) off the drive housing.
8. Inspect the crank (A) for excessive wear and replace parts as needed.
9. Evenly lubricate the inside of the bronze bearing (C) in the bearing housing (21), and the inside of the connecting rod link (D), with high-quality motor oil. Liberally pack the roller bearing (E) in the connecting rod assembly (22) with bearing grease.
10. Assemble the connecting rod (22) and bearing housing (21).
11. Clean the mating surfaces of the bearing and drive housings.
12. Align the connecting rod with the crank (A) and carefully align the locating pins (F) in the drive housing (20) with the holes in the bearing housing (21). Push the bearing housing onto the drive housing or tap it into place with a plastic mallet.

CAUTION

DO NOT use the bearing housing screw (73) to align or seat the bearing housing with the drive housing. These parts must be aligned using the locating pins (F), to help avoid premature bearing wear.

13. Install the screws (73) and lockwashers (74) on the bearing housing. Tighten evenly to 300 in-lb (34 N.m).

14. Refer to **Installing the Pump** on page 31.

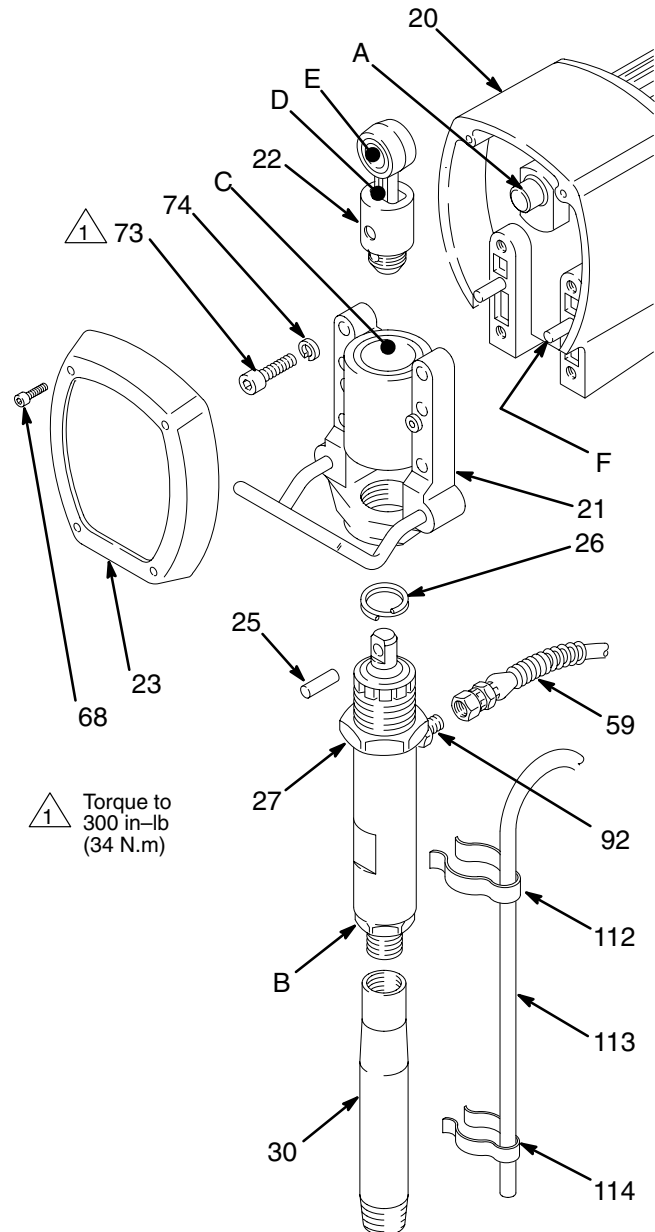

Fig. 6

0149

Drive Housing

WARNING

To reduce the risk of serious injury, including fluid injection always follow the **Pressure Relief Procedure Warning** on page 14 before checking, adjusting, cleaning or shutting off the sprayer. *Disconnect the spark plug!*

CAUTION

DO NOT drop the gear cluster (18) when removing the drive housing (20). The gear cluster is easily damaged. The gear may stay engaged in the drive housing or pinion housing.

DO NOT lose the thrust balls (20c or 19d) located at each end of the gear cluster, or allow them to fall between the gears. The ball, which is heavily covered with grease, usually stays in the shaft recesses, but could be dislodged. If the balls are caught between the gears and not removed, they will seriously damage the drive housing. If the balls are not in place, the bearings will wear prematurely.

NOTE: Refer to Fig. 7 for this procedure.

1. Remove the front cover and screws (23,68).
2. Disconnect the pump outlet hose from the displacement pump nipple. For the upright carts only, remove the spring clips (112, 114) and the drain hose (113) from the pump.
3. Remove the four screws (73) and lockwashers (74) from the bearing housing (21).
4. Lightly tap the back of the bearing housing (21) with a plastic mallet. Pull the pump, bearing housing and connecting rod away from the drive housing as one assembly.
5. Remove the two screws (24) and lockwashers (11). Remove the four screws (10) and lockwashers (11).
6. Lightly tap around the drive housing (20) to loosen the drive housing. Pull the drive housing straight off the pinion housing. Be prepared to support the gear cluster (18), which may also come out.
7. Liberally apply bearing grease to the gear cluster (18). A tube of grease is supplied with each replacement gear cluster. Use a full 6 oz. (160 grams) of grease. Be sure the thrust balls (20c and 19d) are in place.
8. Place the bronze colored washer (20a) and then the silver-colored washer (20b) on the shaft protruding from the big bearing of the drive housing (20). Align the gears and push the new drive housing straight onto the pinion housing and locating pins (B).
9. Starting at Step 4, work backwards to reassemble the sprayer. Or, move ahead to the next section in this manual if further service is needed.

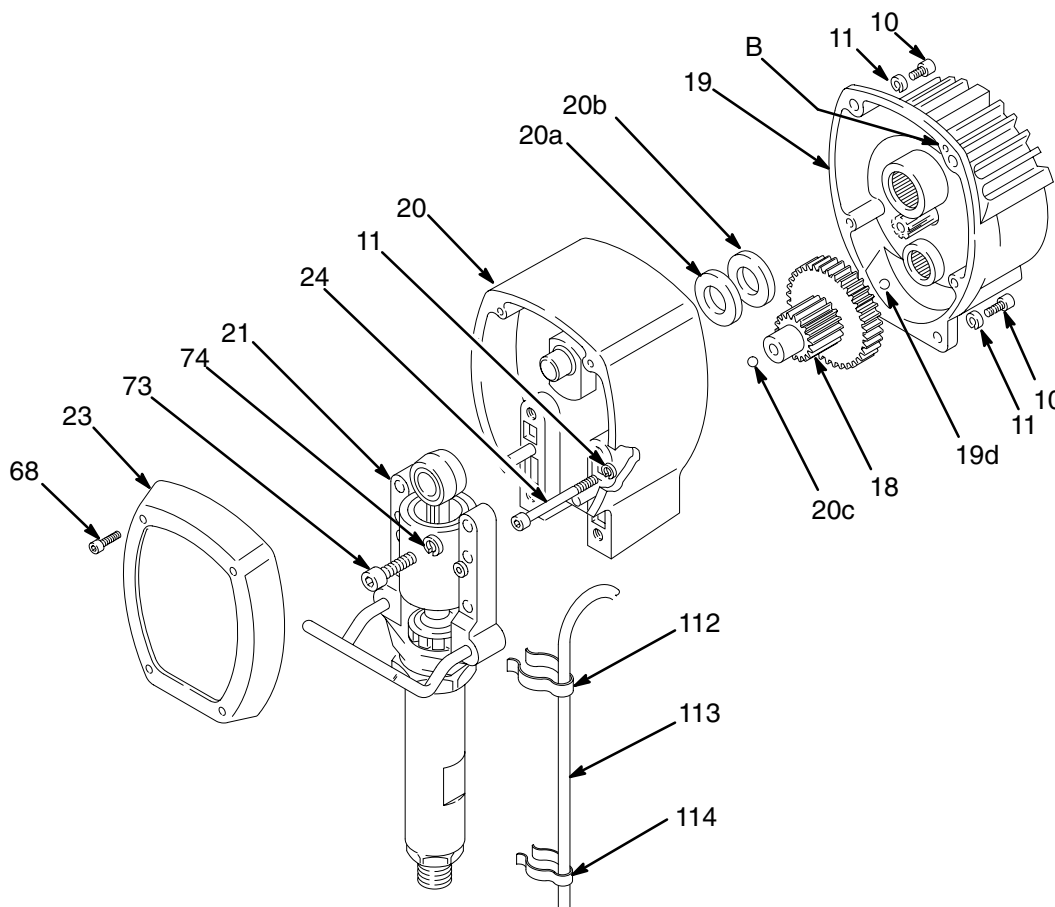

Fig. 7

Pinion, Clutch, Clamp, Field & Engine

Disassembling these parts can start from the pinion housing, or from the clutch if no pinion service is needed.

If starting from the pinion housing, first follow Steps 1 to 6 of **Drive Housing**, on page 19, and then continue with the procedure below.

If starting from the clutch, see page 22.

Pinion

Pinion Housing

WARNING

To reduce the risk of serious injury, including fluid injection always follow the **Pressure Relief Procedure Warning** on page 14 before checking, adjusting, cleaning or shutting off the sprayer. *Disconnect the spark plug!*

NOTE: Refer to Fig. 8 for Steps 1 to 3.

1. Remove the two bottom screws (10) and lockwashers (11) first, and then remove the top three screws (10) and lockwashers (11).

2. Pull the pinion housing away from the clutch housing. The armature (4a) will come with it.
3. Pull the armature (4a) off the hub (19j – see Fig. 9) of the pinion housing.

CAUTION

Do not lose the thrust ball (19d). Refer to the **CAUTION** on page 19 for more information.

NOTE: To disassemble the pinion, go to page 21. To disassemble more of the sprayer, go to page 22. To reassemble the sprayer from this point, skip ahead to **Reassembly**, page 27, Step 7.

 See page 21

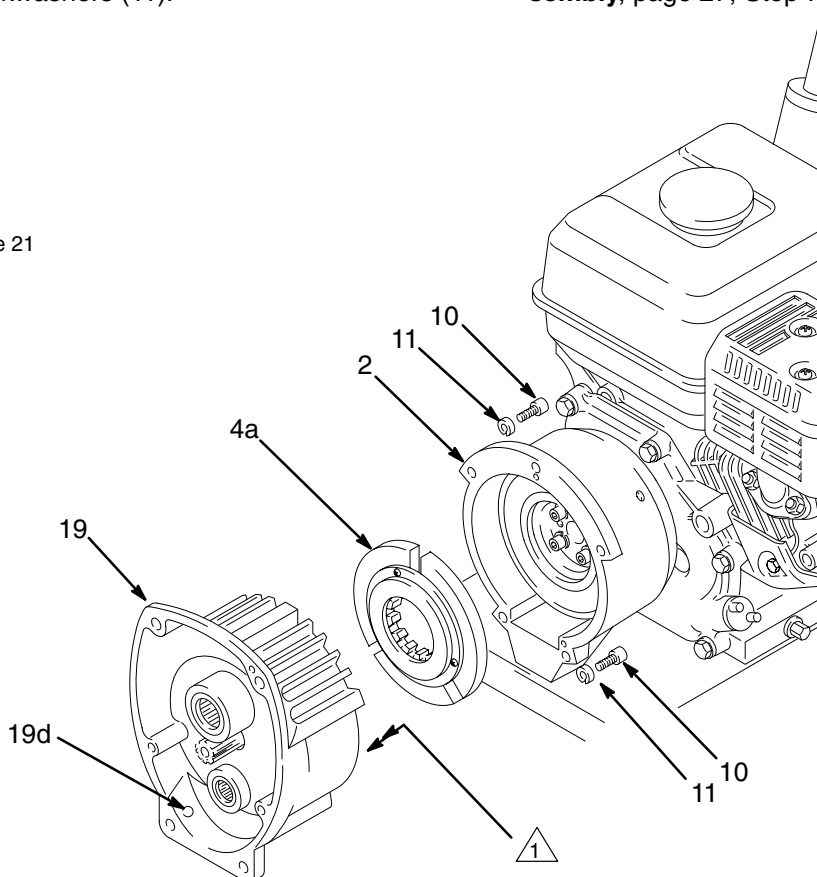

Fig. 8

0171

Pinion Housing

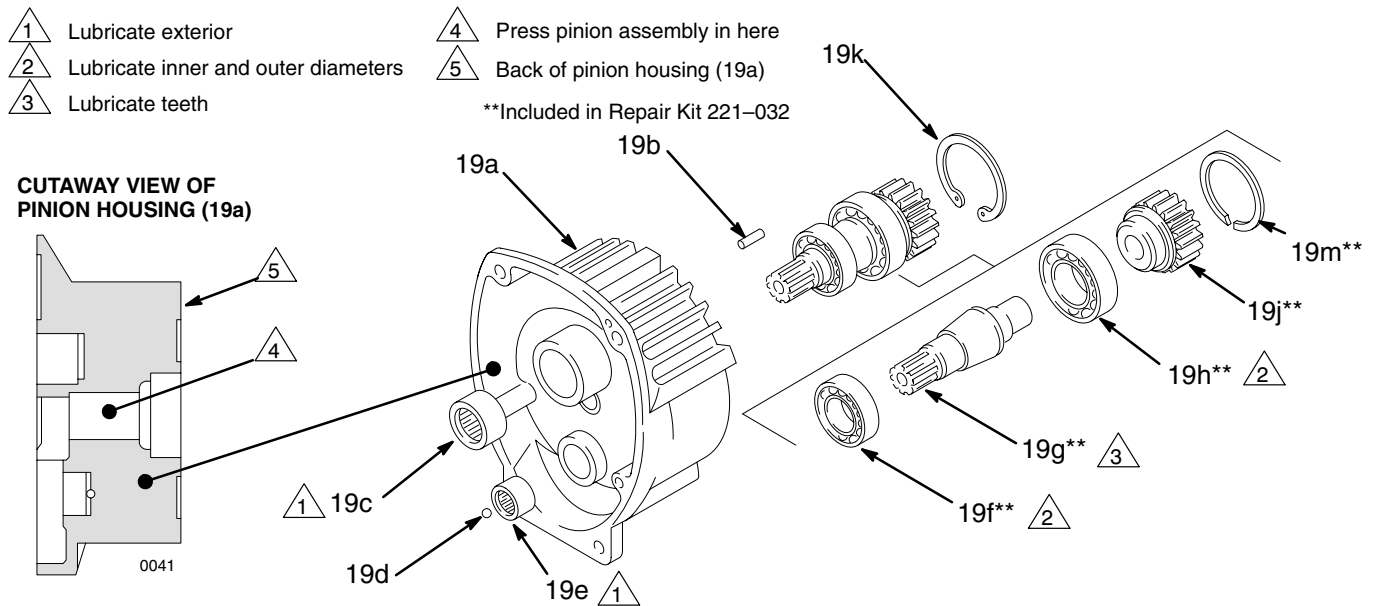

Fig. 9

0169

Repairing the Pinion

NOTE: Refer to Fig. 9 except where noted.

NOTE: A hydraulic press is required if you purchase the pinion parts individually. Otherwise, use Repair Kit No. 221-032, which includes the shaft and bearings pre-assembled and lubricated.

If using Repair Kit 221-032, follow Steps 1 to 5, below.

1. Remove the small ring (19m**) from the hub (19j) and the large ring (19k) from the bearing recess of the pinion housing (19a).
2. Push on the front of the shaft (19g**) to force the bearing and hub assembly out of the housing (19a).
3. Install the new shaft assembly into the pinion housing, pushing it to the shoulder of the housing (19a).
4. Install the rings (19k and 19m**).
5. Go to **Reassembly**, 27, Step 7, or continue on page 22.

If purchasing parts separately, use these instructions. Disassemble as far as needed for the parts being replaced.

NOTE: The old bearings (19h and 19f) will be damaged when removed. Have extra ones on hand if you need to remove them for any reason.

1. Remove the small ring (19m) from the hub (19j).
2. Remove the snap ring (19k) from the bearing recess of the pinion housing (19a).
3. Push on the front of the shaft (19g) to force the bearing (19h) and hub (19j) assembly out of the housing.
4. **Using a hydraulic press**, place pieces of steel bar stock on the inner race of the large bearing (19h) and press the shaft through the hub and bearing. Then turn over the shaft and press out the small bearing (19f). See Fig. 10.

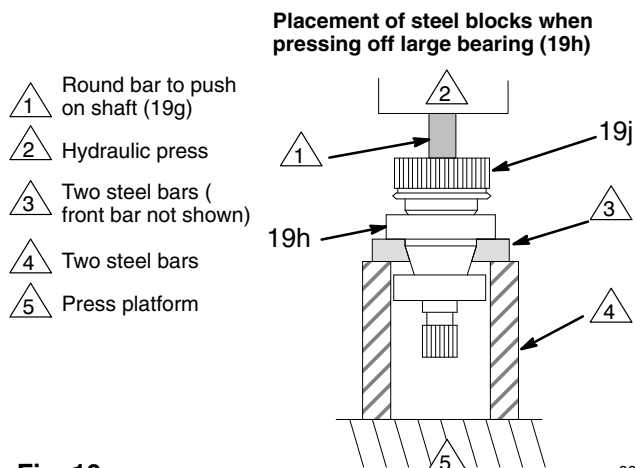

Fig. 10

0043

5. Apply lubricant to the parts as shown in Fig. 9.
6. Press fit the following parts: Large bearing (19h) to the large shoulder of the shaft (19g). Small bearing (19f) to the shoulder of the shaft (19g). Hub (19j) onto the shaft (19g) all the way to the large bearing (19h).
7. Install the shaft assembly, pushing it to the shoulder of the housing (19a).
8. Install the snap ring (19k). Install the small ring (19m).
9. Go to **Reassembly**, 27, Step 7, or continue on page 22.

Clutch

NOTE: The clutch assembly (4) includes the armature (4a) and rotor (4b). The armature and rotor must be replaced together so they wear evenly.

NOTE: If the pinion assembly (19) is not yet separated from the clutch housing (2), follow Steps 1 to 4. Otherwise, start at Step 5.

NOTE: Refer to Fig. 11 for this procedure.

1. Follow the **Pressure Relief Procedure Warning** on page 14.
2. Disconnect the hose (59) from the displacement pump. For the upright cart only, remove the spring clips (112, 114) and drain hose (113).
3. Remove the bottom two screws and lockwashers (10, 11) from the front of the clutch housing (2) and then the remaining three of them.
4. Tap lightly on the back of the bearing housing (21) with a plastic mallet to loosen the assembly (D) from the clutch housing. Pull the assembly away.

5. The armature (4a) was removed with the pinion housing. Remove the armature from the pinion hub.
6. There are two ways to remove the rotor (4b).
 - a. Remove the four socket head capscrews (16) and lockwashers (11). Install two of the screws in the threaded holes in the rotor. Alternately tighten the screws until the rotor comes off. See Fig. 11.
 - b. You can use a standard steering wheel puller (A). However, two 1/4-22- x 3 or 4 in. long screws (B) are also needed. Replace the short screws of the steering wheel puller with the longer screws (B). Turn the screws (B) into the threaded holes of the rotor (4b). Tighten the capscrow (C) of the tool until the rotor comes off. See Fig. 11.
7. Skip ahead to **Reassembly**, page 27, Step 6, or continue on the next page.

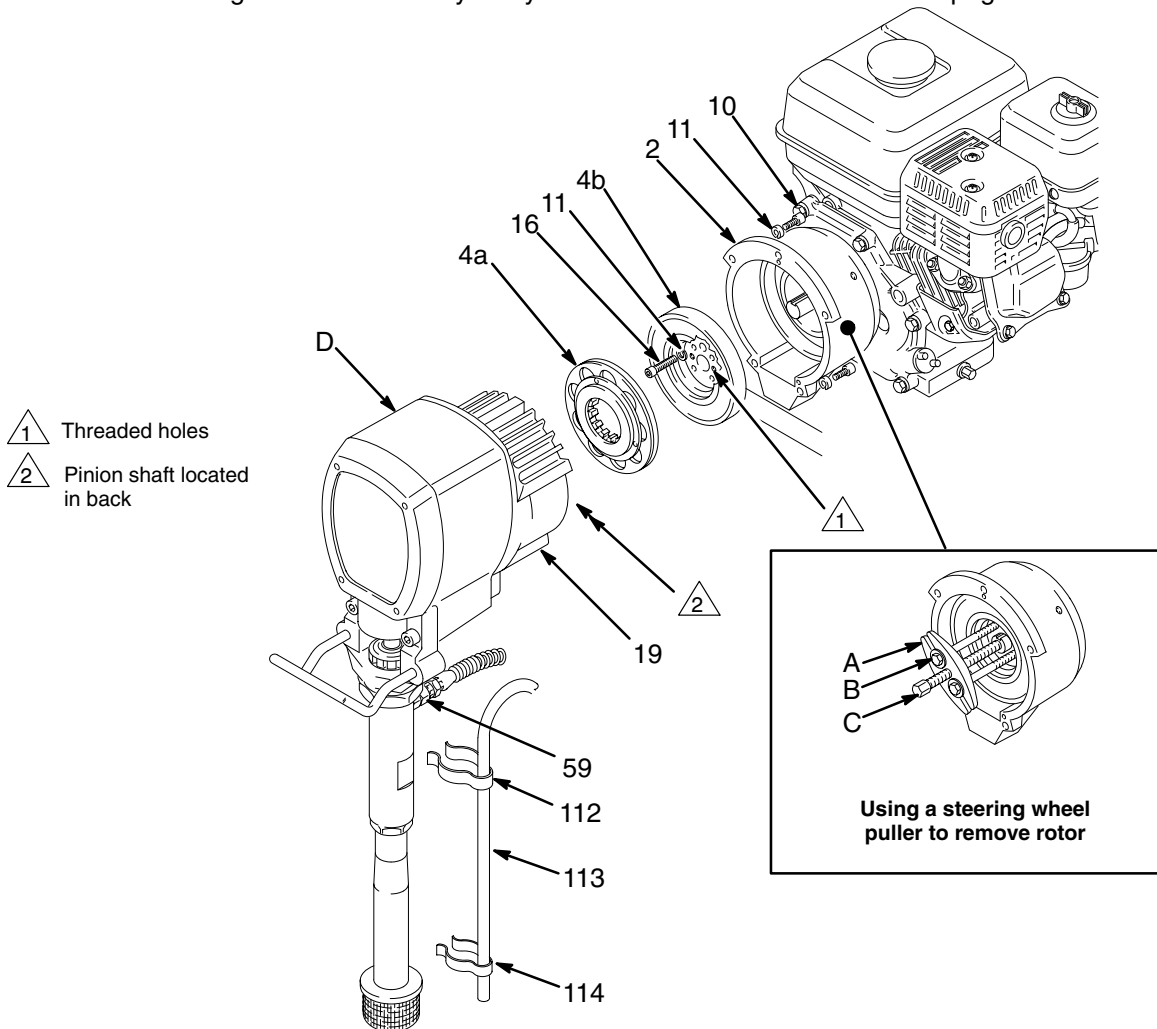

Fig. 11

Engine

NOTE: The engine must be removed before the Field, Clamp and Clutch Housing can be removed.

1. Working under the mounting plate (A) of the cart, remove the screw (15), lockwasher (80) and washer (99) which hold the clutch housing (2) to the cart. See Fig. 13.
2. Still working under the mounting plate, remove the two locknuts (111) and then pull the screws (14) out of the base of the engine. Disconnect the red wire from the engine lead (B). Disconnect the black and white wires from the field. For the upright cart only, loosen the clamp (97). Pull the wires carefully through the grommets (66) before removing the engine. See Fig. 12 and 13.
3. Lift the engine carefully and place it on a work bench.
4. Remove the **Field and Wiring Harness, Clamp** and **Clutch Housing**, as instructed on pages 24 and 25.
5. Skip ahead to **Reassembly**, page 27, Step 5.

NOTE: All service to the engine must be performed by an authorized HONDA dealer.

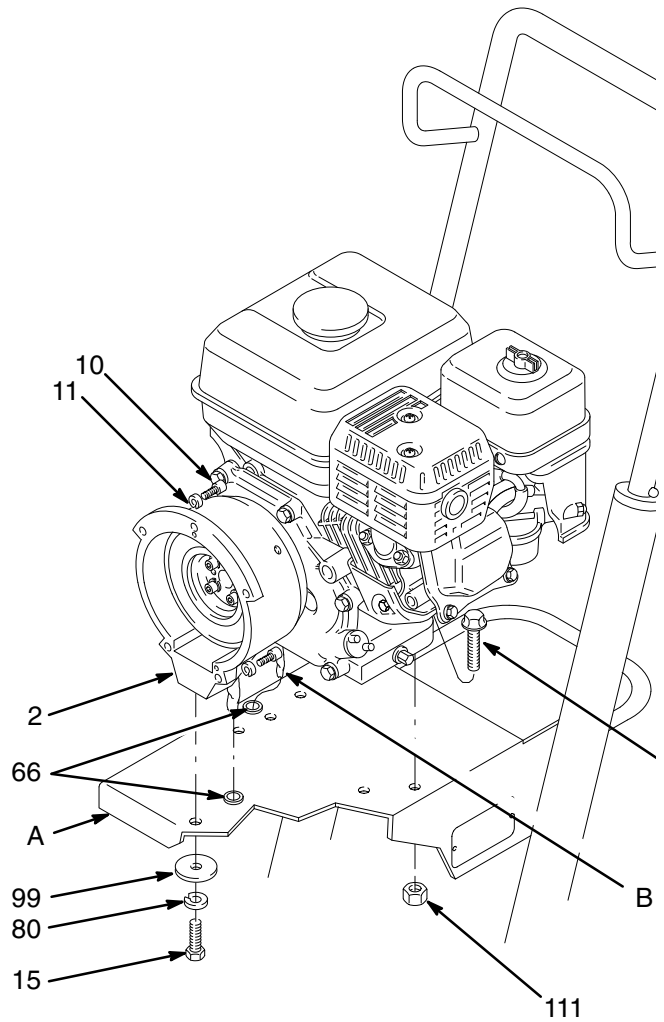

Fig. 12

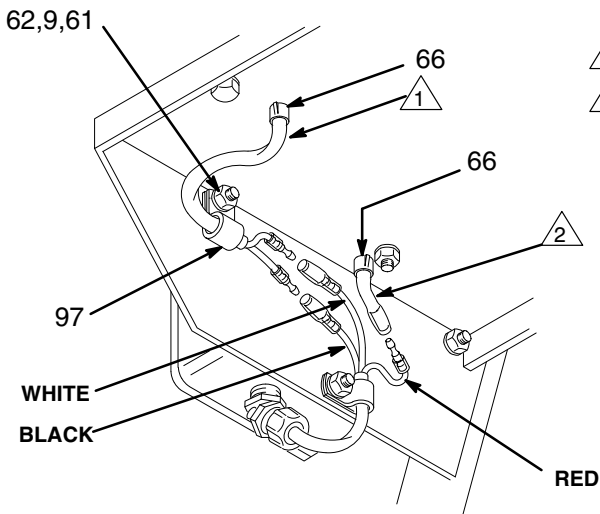
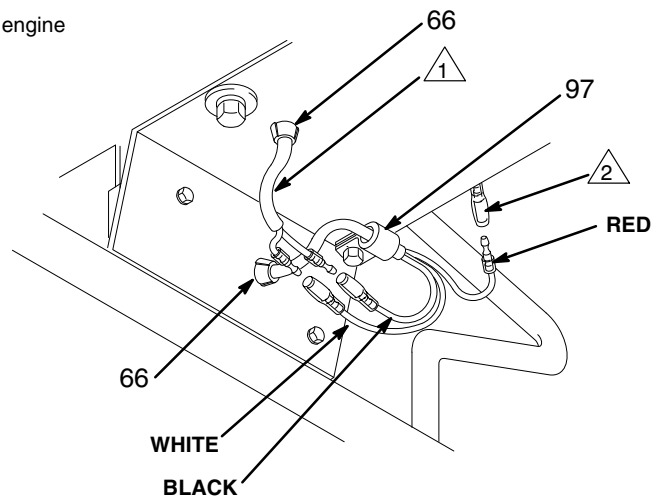

Fig. 13 View from under engine mounting plate on upright cart

- 1 To field
- 2 To engine



View from under engine mounting plate on lo-boy cart

0154

0147

Field and Wiring Harness

NOTE: Refer to Fig. 14.

1. Remove the engine from the cart. See page 23.
2. Pull the plastic caps (B) off the wire screws (98) in both places on the field. Loosen the screws and release the wires (96).
3. Loosen the four setscrews (12) holding the field (6) to the clutch housing (2).
4. Pull off the field.
5. Skip ahead to **Reassembly**, page 26, Step 4 or continue on page 25.

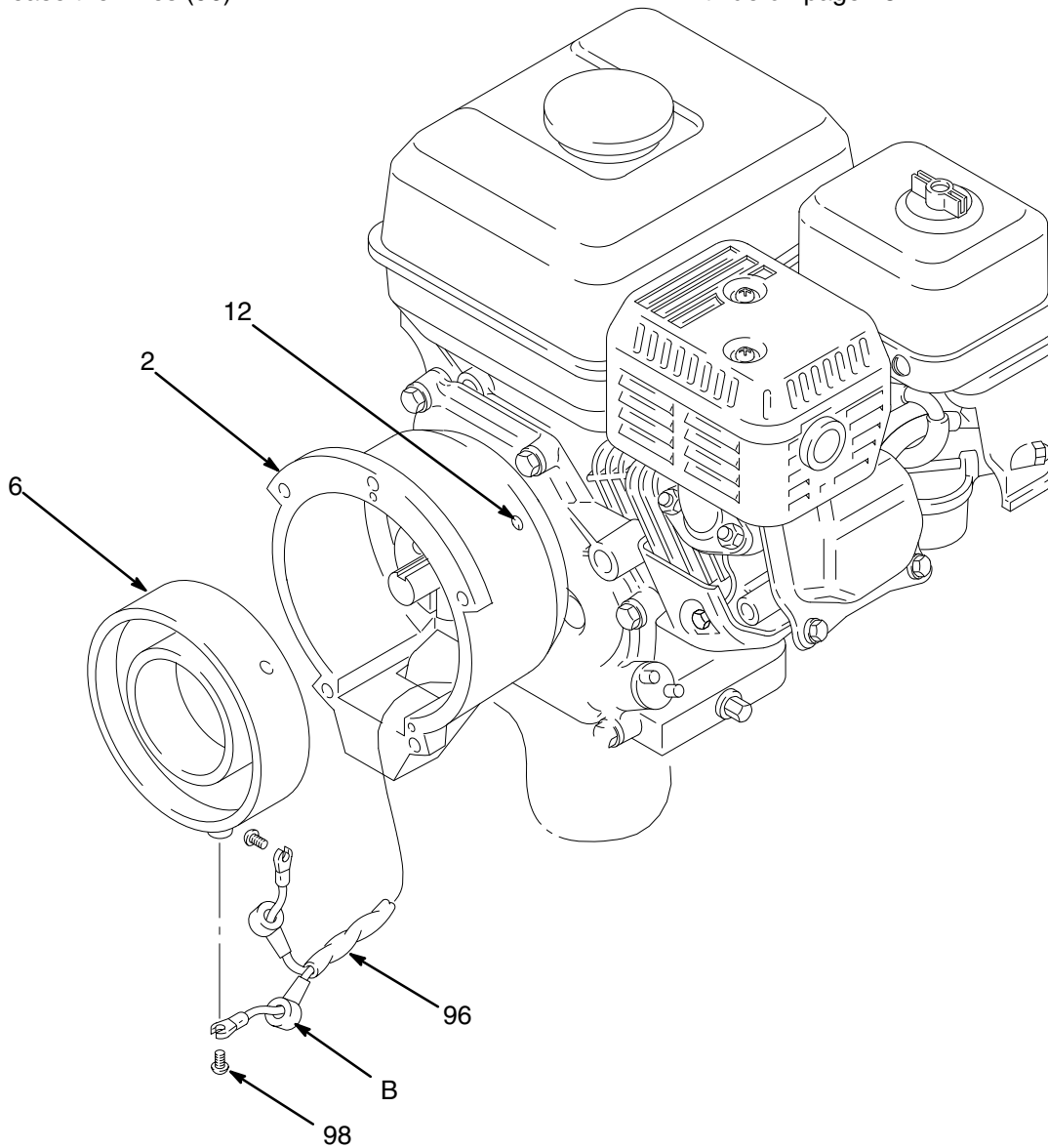

Fig. 14

0046

Clamp

NOTE: A standard steering wheel puller and two 1/4–28 x 3 or 4 in. long screws are required to remove the clamp.

NOTE: Refer to Fig. 15.

1. Loosen the two screws (16) on the clamp (3), working through the slot at the bottom of the clutch housing (2).
2. Install two screws (B) of the tool (A) in two of the threaded holes in the clamp (3). Tighten the screw (C) until the clamp comes off.
3. Skip ahead to **Reassembly**, page 26, Step 3, or continue to the right.

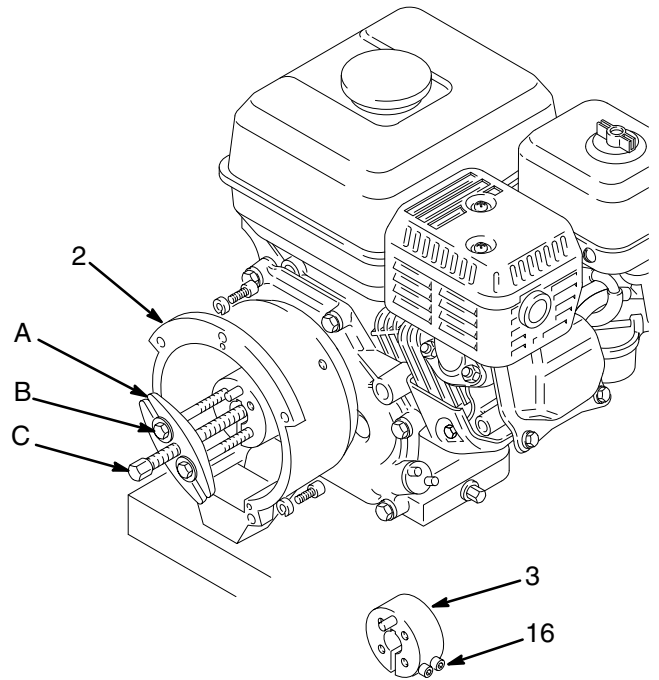

Fig. 15

0155

Clutch Housing

NOTE: Refer to Fig. 16.

1. Remove the four capscrews (8) and lockwashers (9) which hold the clutch housing (2) to the engine.
2. Remove the capscrew (15), lockwasher (80) and washer (99) from beneath the mounting plate (D).
3. Remove the engine key (13).
4. Pull off the clutch housing (2).
5. Skip ahead to **Reassembly**, page 26, Step 1.

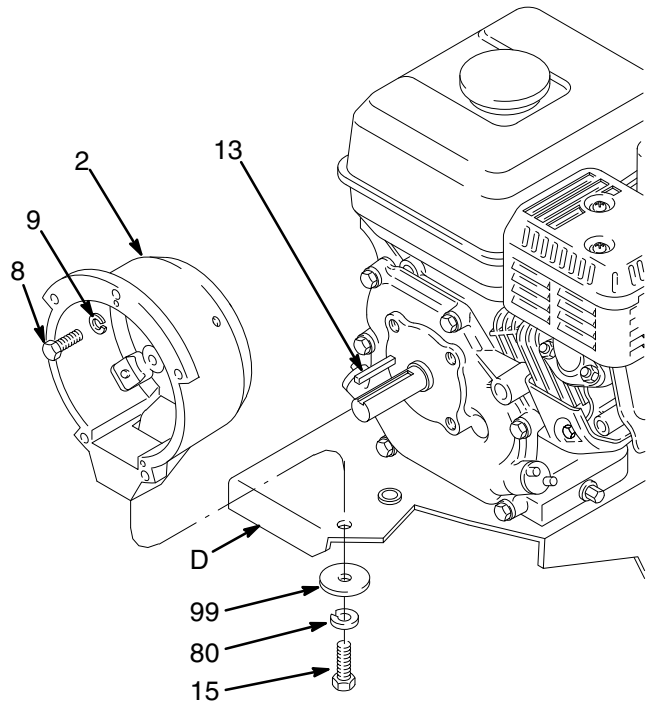

Fig. 16



0156

Reassembly

1. Install the **clutch housing (2)**, capscrews (8) and lockwashers (9) on the engine. See Fig. 17.
2. Install the engine shaft **key (13)**. See Fig. 17.
3. Press the **clamp (3)** onto the engine shaft. Maintain the 1.99 in. \pm 0.01 (50.55 mm) dimension shown in Fig. 18.

To check the dimension, place a rigid, straight steel bar (B) across the face of the clutch housing (2). Use an accurate measuring device to measure the distance between the bar and the face of the clamp. Adjust the clamp as necessary. Torque the two screws (16) to 120 in-lb (14 N.m).

4. Install the **field (6)** in the clutch housing (2). Working through the slot in the clutch housing, connect the wires of the harness (96) to the screws (98) in both places on the field. Pull the plastic caps (C) up and snap them over the screws. With the setscrew holes in the field and the clutch housing (2) aligned, tighten the setscrews (12) oppositely and evenly, to 27 in-lb (3.2 N.m). See Fig. 17.

-  Torque oppositely and evenly to 27 in-lb (3.2 N.m)
-  Slot

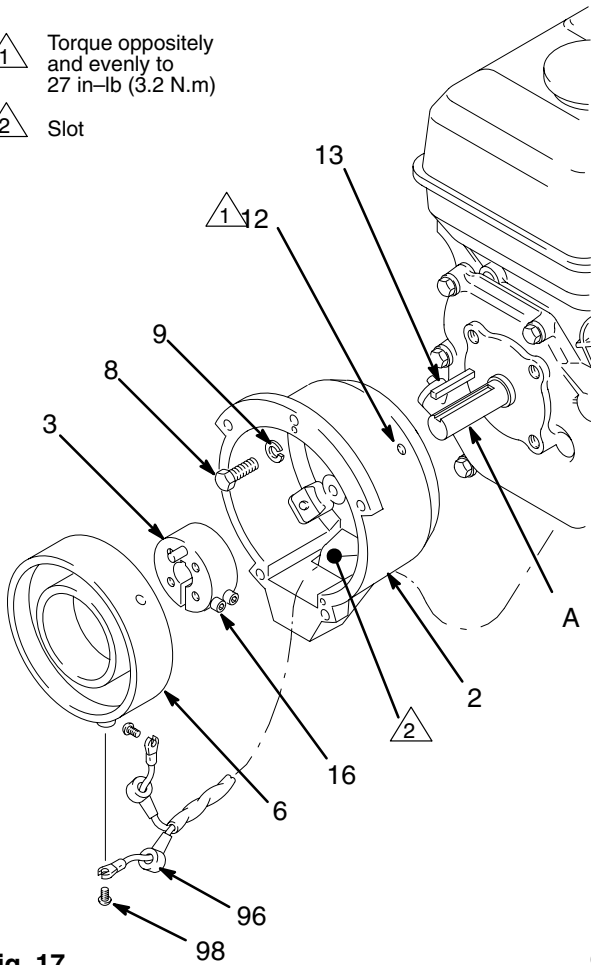

Fig. 17

0049

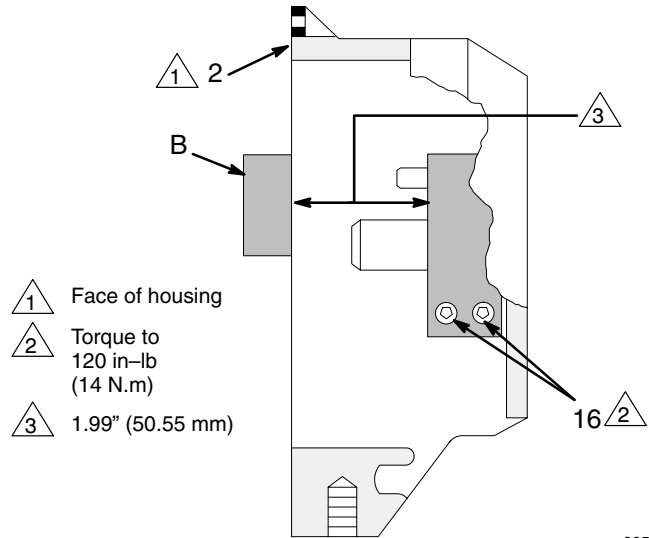

Fig. 18

0050

Reassembly







- Place the **engine (1)** assembly on the cart. Align the mounting holes. Carefully guide the engine wire (D) and wiring harness (96) from the field, through the appropriate grommets (66) in the mounting plate (E). Install the flange screws (14) and locknuts (11). Torque to 15 ft-lb (20.4 N.m). Install the capscrew (15), lockwasher (80) and washer (99) from under the engine mounting plate to the clutch housing (2). Connect the engine wire (D) to the red wire, and connect the black and white wires as shown in the Detail drawing in Fig. 19.
- Be sure the face of the **rotor (4b)** and the field is free of all oil and contaminants. Remove any burrs on the outside edge of the rotor. Install the rotor, lockwashers (11) and capscrews (16). Torque the capscrews to 7 ft-lb (9.5 N.m). See Fig. 19.

After installing the rotor (4b), check the clearance between the outside diameter of the rotor and the in-

side diameter of the field. The clearance must be at least 0.010 in. (0.25 mm) all the way around. Use shim stock or feeler gauge. If necessary, loosen the setscrews (12) and reposition the field. Tighten the setscrews evenly to 27 in-lb (3.2 N.m).

Be sure the face of the **armature (4a)** is clean. Assemble the armature to the shaft in the pinion housing (19). A retaining ring located within the armature makes it difficult to assemble these parts. Follow this procedure for the best results. First, engage a few splines of both parts. While they are engaged, use a screwdriver to gently push the retaining ring into the armature, and finish engaging the splines. Push the armature onto the shaft until it contacts the ring (19m). See Fig. 19.

- Assemble the **pinion housing (19)** to the clutch housing, using the capscrews (10) and lockwashers (11). See Fig. 19.

-  Torque to 7 ft-lb 99.5 N.m)
-  Spline
-  Face must be clean
-  Torque to 15 ft-lb (20.4 N.m)
-  To field (ref. 96)
-  To engine (ref. D)

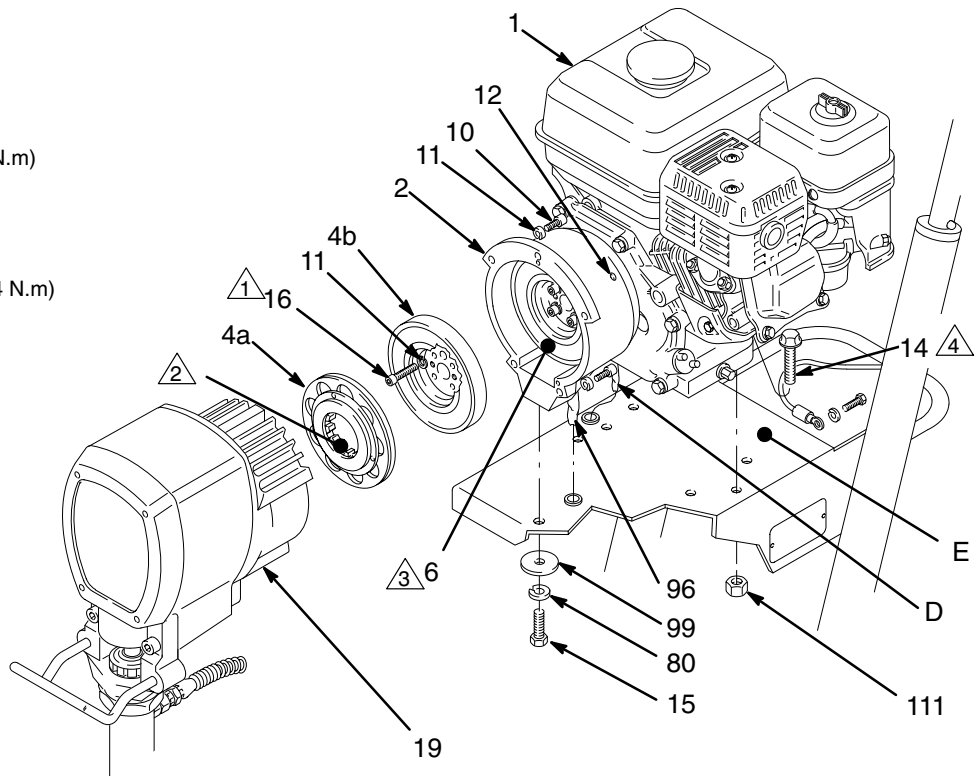

0157

— View from under engine mounting plate on Lo-Boy cart —

— View from under engine mounting plate on upright cart —

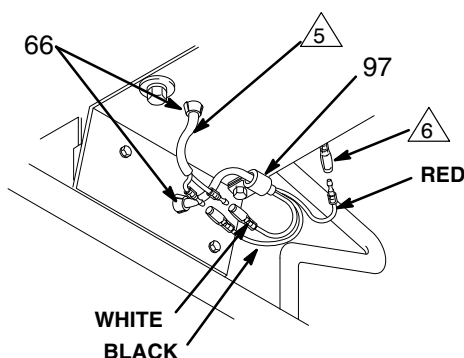
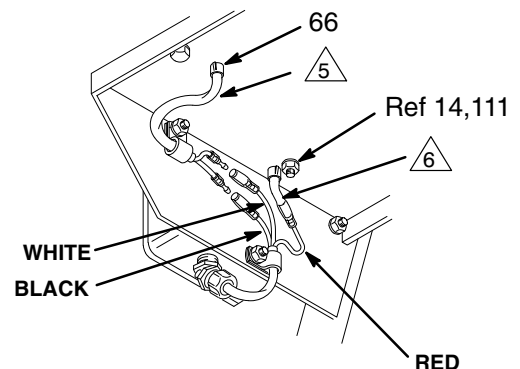

Fig. 19

0147



0146

Pressure Control Replacement

WARNING

To reduce the risk of serious injury, including fluid injection always follow the **Pressure Relief Procedure Warning** on page 14 before checking, adjusting, cleaning or shutting off the sprayer. *Disconnect the spark plug!*

1. Disconnect both hoses at the pressure control (63), while holding the elbows (317 or 320) firmly. See the **CAUTION**, below. Note the original location of each hose to be sure you reassemble them correctly at the end of this procedure. See Fig. 20.

CAUTION

DO NOT allow the elbow (317 or 320) to turn when removing or connecting the hoses. Turning the elbows can damage the sensitive bourdon tube.

2. Working under the engine mounting plate of the cart, disconnect the red, black and white wires.

For the upright cart, remove the three nuts (61) and lockwashers (9) from the capscrews (62). See Fig. 21.

For the lo-boy cart, remove the three screws (62) and washers (9). See Fig. 21.

3. Remove the wire clamp (97). See Fig. 21. Remove the pressure control.
4. Remove the pressure control cover (76) and the mounting bracket (67 or 107). See Fig. 20.

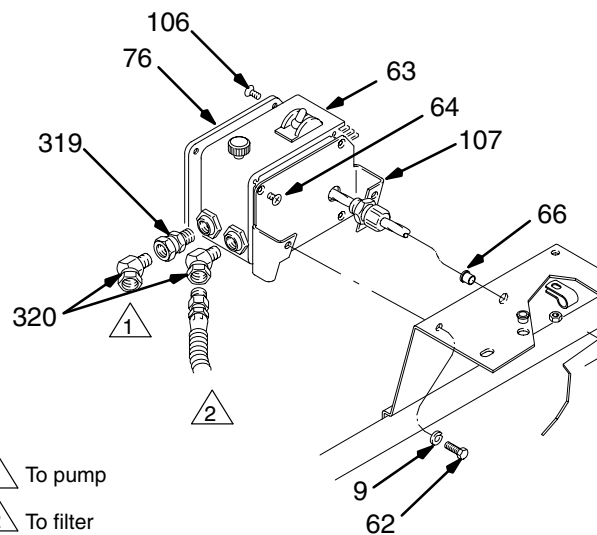
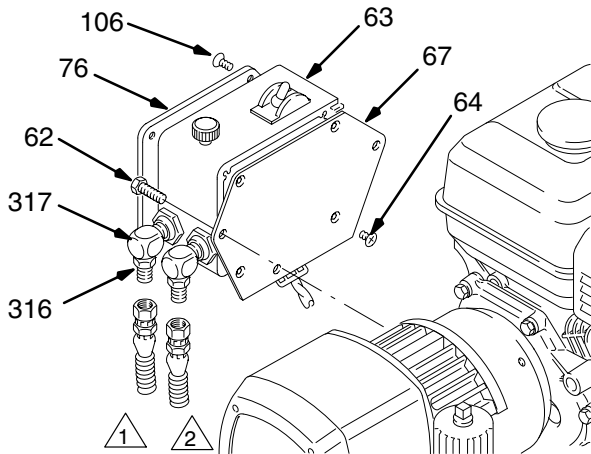

△ 1 To pump
△ 2 To filter

Fig. 20

UPRIGHT CART

0144

LO-BOY CART

0145

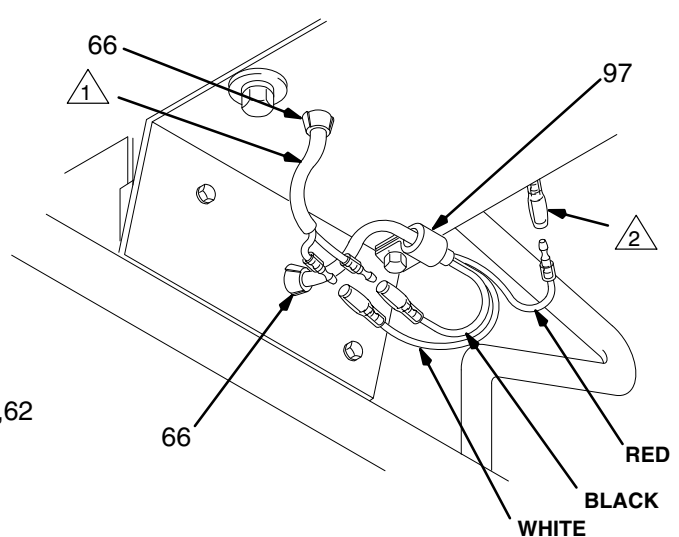
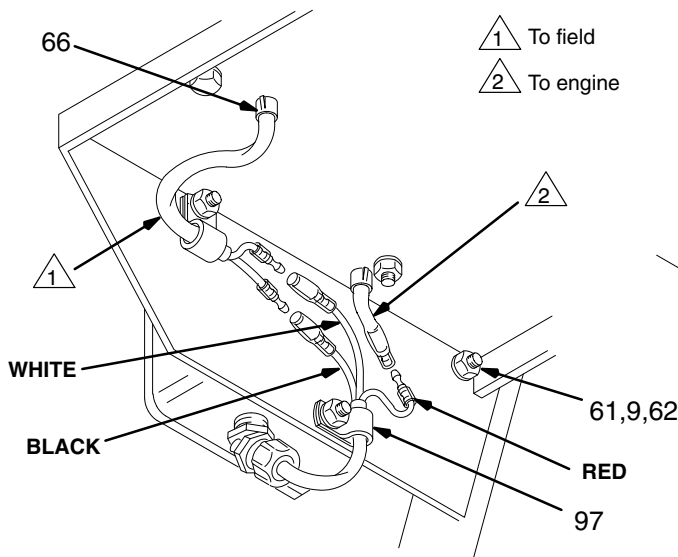

Fig. 21

View from under engine mounting plate on upright cart

0146

View from under engine mounting plate on lo-boy cart

0147

Pressure Control Replacement

5. Disconnect the black, red and white wires from the rectifier (307) and switch (302), which are sheathed with the conductor (314). See Fig. 22.
6. Unscrew the connector (318 or 108) from the control box, pulling the conductor and wires out with it.
7. For the upright cart, remove the nipple (316) from the elbow (317). See Fig. 22.
8. Use a wrench to hold the hex of the adapters (A) while removing the elbows (317, or 320 and 319).
9. Reassemble in the reverse order.
10. For the upright carts, guide the new pressure control wires through the wire clamps (97). Fasten the wire-clamps to the cart with the same screws, lock-washers, and nuts (61, 9, 62) which hold the bracket (76) to the cart. See Fig. 20.
11. For the lo-boy carts, guide the pressure control wires through the single wire clamp (97), and install the screws and washers (62, 9) to hold the bracket (107) to the cart. See Fig. 20.
12. Perform the **Pressure Control Adjustment** on page 30 before regular operation of the sprayer.

For Upright cart sprayers

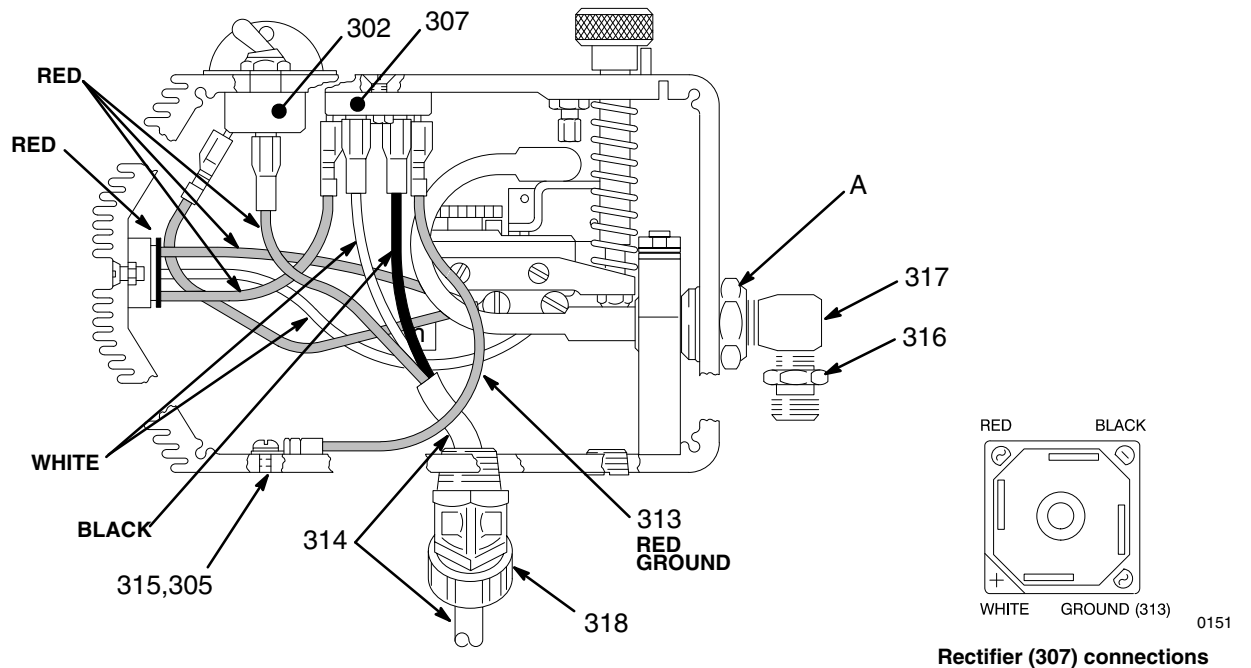

Rectifier (307) connections

0148

For Lo-Boy cart sprayers

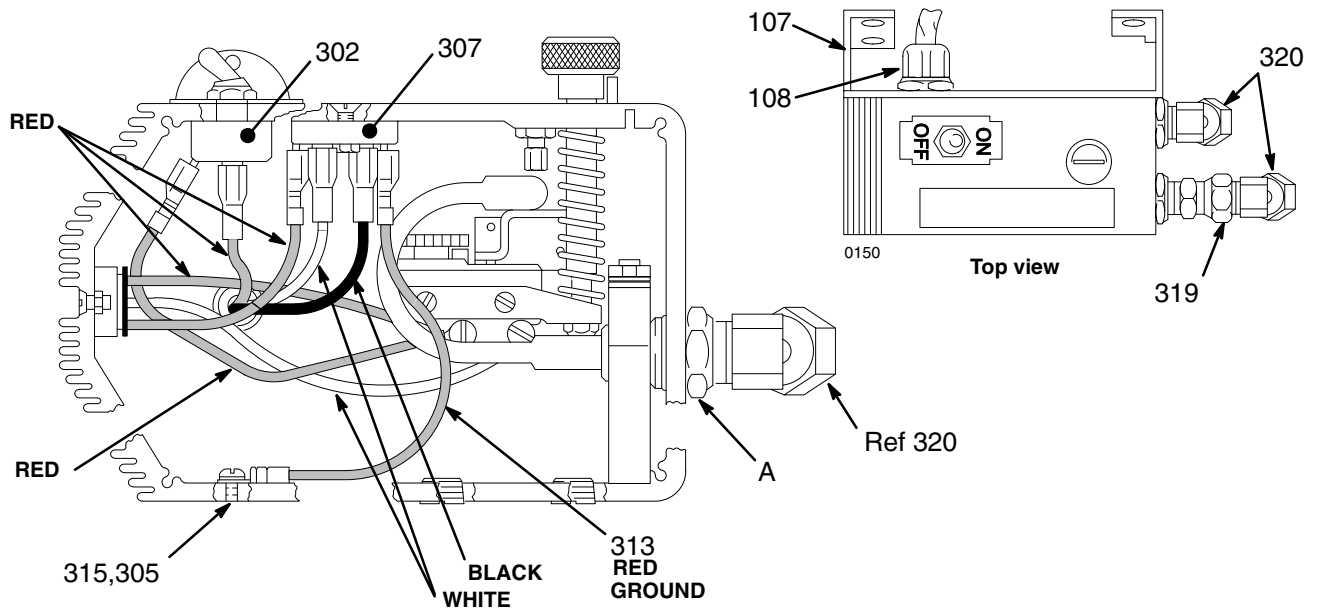

Fig. 22

0165

Pressure Control Adjustment

WARNING

USE EXTREME CAUTION WHEN PERFORMING THIS CALIBRATION PROCEDURE to reduce the risk of a fluid injection injury or other serious injury, which can result from component rupture, electric shock, fire, explosion or moving parts.

This procedure sets the sprayer to 2600–3000 psi (182–210 bar) MAXIMUM WORKING PRESSURE.

This procedure must be performed when the pressure control assembly is removed and reinstalled, or replaced, to be sure the sprayer is properly calibrated.

Improper calibration can cause the sprayer to over-pressurize and result in component rupture, fire or explosion. It may also prevent the sprayer from obtaining the maximum working pressure, resulting in poor sprayer performance.

NEVER attempt to increase the fluid outlet pressure by performing these calibrations in any other way.

NEVER EXCEED 3000 psi (210 bar) MAXIMUM WORKING PRESSURE. Normal operation of the sprayer at higher pressures could result in component rupture, fire or explosion.

ALWAYS use a *new* 50 foot (15.2 m) spray hose, rated for at least 3000 psi (210 bar) MAXIMUM WORKING PRESSURE, when performing this procedure. A used, under-rated hose could develop a high pressure leak or rupture.

AVOID touching the wires in the pressure control assembly when the control box cover is removed, to reduce the risk of electric shock.

Service Tools Needed

- **NEW** 50 foot (15.2 m), 3000 psi (210 bar), flexible nylon, airless spray hose, p/n 223–541
- 0–5000 psi (0–350 bar) fluid-filled pressure gauge, p/n 102–814
- **NEW** spray tip, size 0.025 to 0.029
- 3/8 in. ignition wrench or nut driver
- 5 gallon pail and water or mineral spirits
- Swivel, p/n 156–823
- Nipple, p/n 162–453
- Tee, p/n 104–984

Set Up

1. Follow the **Pressure Relief Procedure Warning** on page 14.
2. Set up the system as shown in Fig. 23.

Set the Dead Band (Pressure Differential)

NOTE: Do not alter this adjustment if the wheel is already set as shown in Fig. 24.

1. Remove the pressure control cover.
2. Set the white differential wheel (A) on the micro-switch. Turn the wheel so the letter **F** is concealed behind the switch and the letter **A** is the first letter seen.

Pressure Up

1. Start the sprayer and prime it.
2. Adjust the pressure to 2600 psi (180 bar).
3. Shut off the engine. If the pressure drops, replace pump packings before proceeding. See page 31.

Adjust the Pressure

See Fig. 25.

1. Remove the pressure control plug (326).
2. Turn and hold the pressure control knob (B) at the maximum pressure setting.
3. Engage the nut (C): insert the nut driver through the pressure control hole, or use the ignition wrench from the front of the pressure control.
 - a. Loosen the nut just until you hear a click. STOP.

- a. Loosen the nut just until you hear a click. STOP.
 - b. Slowly tighten the nut just until another click is heard. STOP.
4. Replace the plug (326) and pressure control cover.

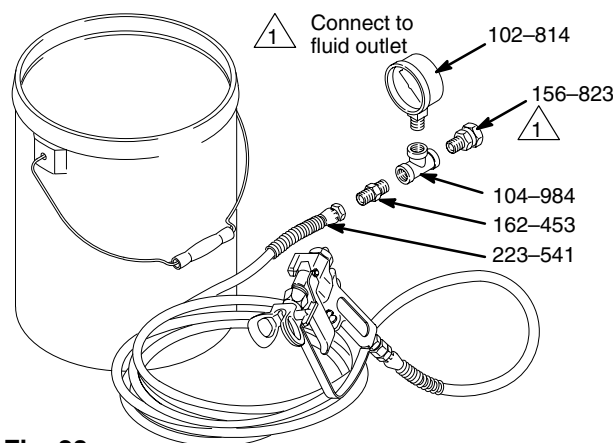

Fig. 23

0474

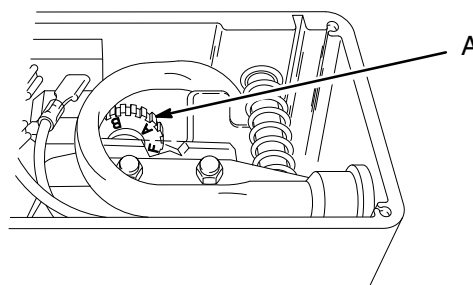

Fig. 24

0475

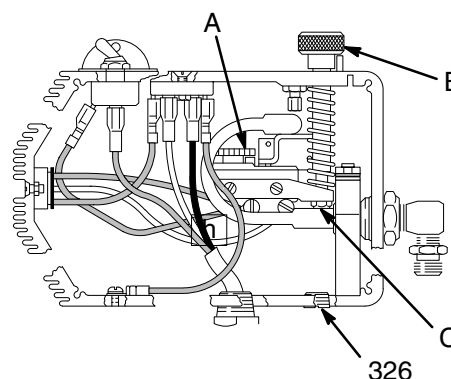

Fig. 25

0151

Removing and Installing the Pump

WARNING

To reduce the risk of serious injury, including fluid injection always follow the **Pressure Relief Procedure Warning** on page 14 before checking, adjusting, cleaning or shutting off the sprayer. *Disconnect the spark plug!*

Removing the pump See Fig. 26.

1. Flush the pump. Relieve pressure. See page 14.
2. Hold the intake valve (423) with a wrench and unscrew the suction tube (30). Remove the hose (59). For upright carts, remove the spring clips (112,114) and drain hose (113).
3. Push the retaining spring (26) up. Push the pin (25) out the rear.
4. Loosen the locknut (27). Unscrew the pump. See below for how to repair the pump.

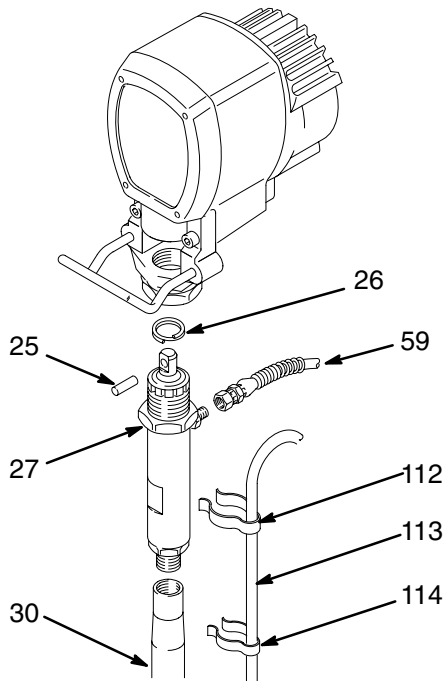

Fig. 26

0477

Installing the pump See Fig. 27.

1. Screw the pump about 3/4 of the way into the bearing housing (21). Hold the pin (25) up to the pin hole on the connecting rod (22) and continue screwing in the pump until the pin slides easily into the hole.
2. Back off the pump until the top threads of the pump cylinder are flush with the face of the bearing housing and the outlet nipple faces back.
3. Push the retaining spring (26) into the groove all the way around the connecting rod. Tighten the locknut (27) to 90 ft-lb (110 N.m) using a 2 1/4 in. open end wrench and a light hammer.
4. Install the front cover and screws. Connect the pump outlet hose. Install the suction tube parts. For Upright carts, install the spring clips and drain hose.

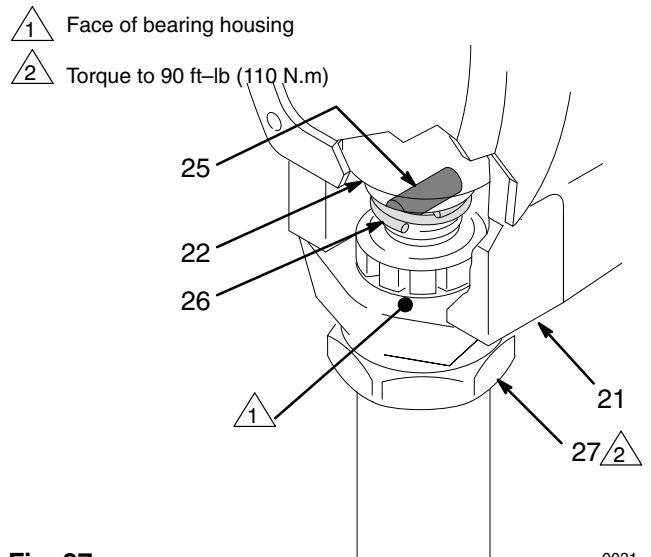

Fig. 27

0031

Displacement Pump Repair

Disassembly procedure

1. Remove the pump from the sprayer. See above.
2. Disassemble the intake valve. See Fig. 28.
3. Clean and inspect the parts. Replace any worn or damaged parts. Use a new o-ring (401*). If no further service is needed, reassemble the intake valve and torque it into the cylinder to 110 ft-lb (146 N.m).

1 Torque to 110 ft-lb (146 N.m)

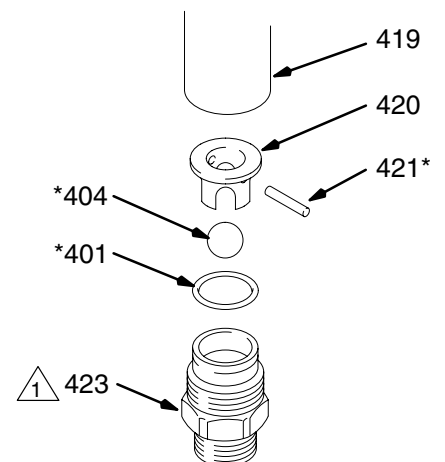

Fig. 28

Displacement Pump Repair

- To disassemble the rest of the pump, remove the packing nut (416) and plug (405). See Fig. 33.
- Use a plastic mallet to tap the piston rod (424) down. Pull the rod out through the bottom of the cylinder.
- Remove the throat packings. See Fig. 33.

WARNING

Always use the special sleeve removal tool, P/N 220-991, to remove the sleeve. Other removal methods could cause the pump to rupture, resulting in serious injury. If the sleeve cannot be removed easily using the tool, return the sleeve and cylinder to your Graco distributor for removal.

- Remove the sleeve. Screw the large nut (B) of the tool into the top of the cylinder (419). Screw down the rod (A) to push the sleeve out. Remove the tool. See Fig. 29.
- Clamp the flats of the piston rod (424) in a vise. Loosen the retaining nut (411). Unscrew the piston valve (422). See Fig. 30.
- Disassemble the piston valve (422). See Fig. 30.

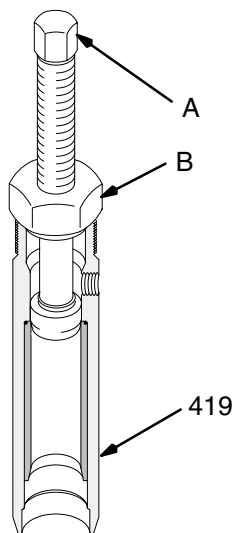

Fig. 29

0028

Reassembly Notes

- Pump Repair Kit, P/N 220-877, is available. For the best results, use all the new parts in the kit, even if the old ones still look good. Parts included in the kit are shown with an asterisk, e.g., (410*) in the text and drawings.
- Check the outside of the piston rod (424) and the inside of the sleeve (418) for scoring or scratches. If the parts are damaged, new packings will not seal properly. Replace these parts if needed.

- Alternate leather and plastic packings as shown in Fig. 30. The lips of the throat “V” packings must face down. The lips of the piston “V” packings must face up. The lips of the U-cup seal (403) face down. Incorrect installation damages the packings and causes the pump to leak.
- Soak leather packings in oil before reassembling the pump.

Reassembly Procedure

- Stack the backup washer (414), seal (403*), female gland (415*), alternate the packings (412*,406*), and then male gland (410*) onto the piston valve (422). See Fig. 30.
- Tighten the packing retaining nut (411) onto the piston valve (22) to the torque specified in Fig. 30.
- Put the ball (425*) on the piston valve (422). See Fig. 30.

CAUTION

Step 5, tightening the piston valve into the rod, is critical. Follow the procedure carefully to avoid damaging the packings by overtightening.

- Apply one drop of adhesive, supplied, to the threads of the piston valve. Then hand tighten the valve assembly into the piston rod just until the nut (411) contacts the rod. See Fig. 30.
- Place the flats at the top of the rod (424) in a vise.

NOTE: Note the alignment of the piston (422) to the nut (411). Maintain this alignment through Steps 5, 6 and 7.

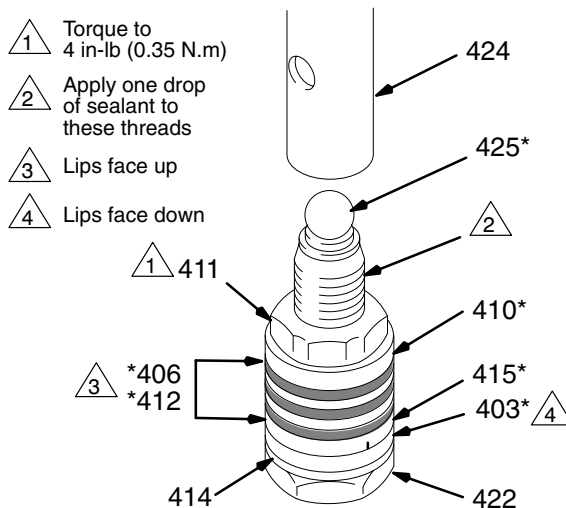

Fig. 30

0029

Displacement Pump Repair

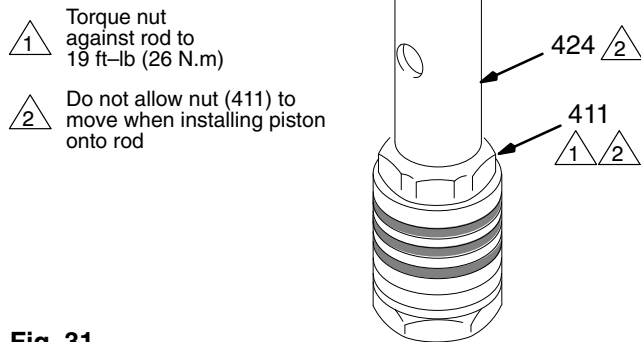

Fig. 31

- Use a wrench to **CAREFULLY** tighten the nut (411) against the piston rod to 19 ft-lbs (26 N.m). See Fig. 31.

NOTE: Use two wrenches to maintain the alignment mentioned in the NOTE following Step 4, page 32.

- Put a new o-ring (417*) firmly in the cylinder groove. See Fig. 33.
- One at a time stack the male gland (408*), alternate the packings (413*, 407*), and then install the female gland (409*), into the top of the cylinder (419). See Fig. 33.
- Install the packing nut (416) and plug (405), but leave loose for now. See Fig. 33.

NOTE: The tapered end of the sleeve is the bottom of it. Do not install it upside down. See Fig. 32.

- Coat the piston rod and packings with oil. Carefully slide the assembly (A) **INTO THE TOP OF THE SLEEVE (418)**. Then slide the sleeve/piston rod assembly **INTO THE BOTTOM OF THE CYLINDER (419)**. This procedure helps prevent damaging the packings during reassembly. See Fig. 32.

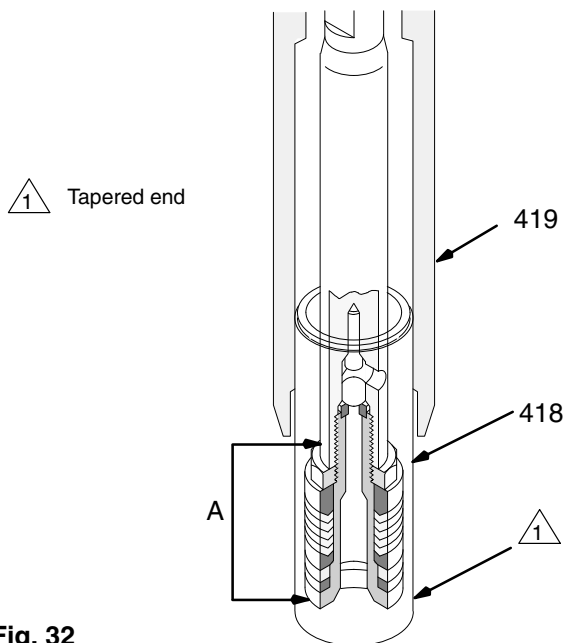

Fig. 32

0030

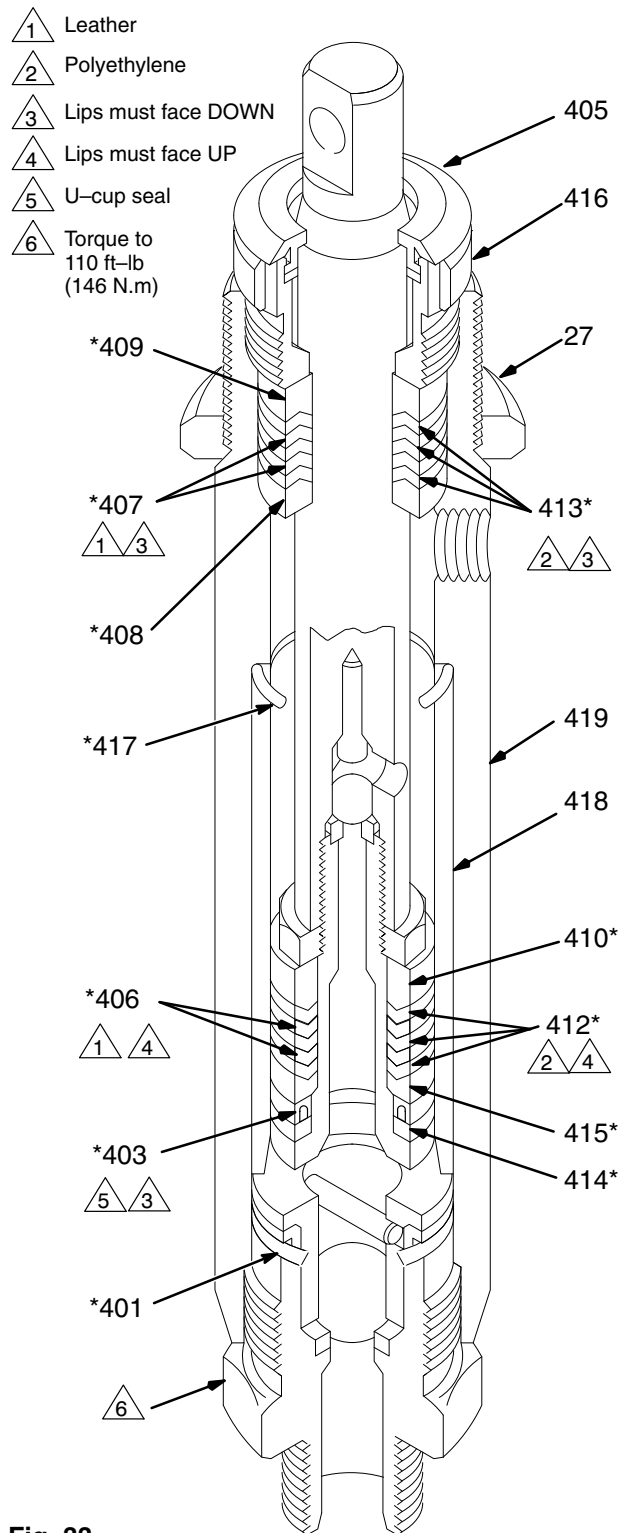

Fig. 33

- Screw down the cylinder locknut (27) until it is finger tight at the bottom of the external cylinder threads.
- Put the flats of the intake valve (423) in a vise. Install a new o-ring (401*) and screw the intake valve into the pump cylinder. See Fig. 33. Torque the valve to 110 ft-lb (146 N.m).
- Reinstall the pump. See page 31.

Parts – Displacement Pump

Model 220–872, Series A

Includes items 401 to 425

REF NO.	PART NO.	DESCRIPTION	QTY
401*	107–098	PACKING, o-ring, PTFE	1
403*	108–690	SEAL, u-cup, polyurethane	1
404*	108–775	BALL; sst	1
405*	183–171	PLUG 1	1
406*	183–174	V-PACKING, leather	2
407*	183–175	V-PACKING, leather	2
408*	183–176	GLAND, male	1
409*	183–177	GLAND, female	1
410*	183–178	GLAND, male	1
411	183–179	NUT, hex, retaining	1
412*	183–182	V-PACKING, polyurethane	3
413*	183–183	V-PACKING, polyurethane	3
414*	186–653	WASHER, backup	1
415*	183–185	GLAND, female	1
416	183–186	NUT, packing	1
417*	183–172	O-RING, PTFE	1
418	183–361	SLEEVE, cylinder	1
419	183–181	CYLINDER	1
420	183–180	GUIDE, ball	1
421*	183–173	PIN, ball stop	1
422	220–631	VALVE, piston	1
423	220–629	VALVE, intake	1
424	220–630	ROD, piston	1
425*	101–947	BALL	1

* These parts are also included in Repair Kit 220–877, which may be purchased separately. Keep an extra kit on hand to reduce down time.

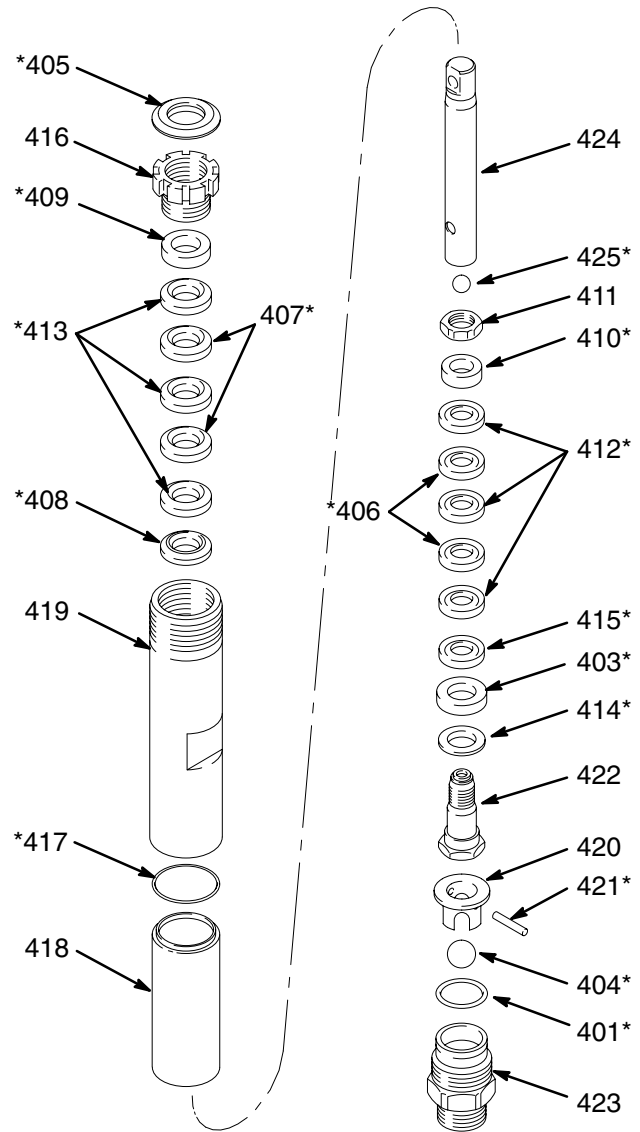

Accessories

- 224–788** Sleeve Removal Tool
- 220–877** Packing Repair Kit
See contents in parts list, above

Parts – Complete Sprayers

Model 231–052 Sprayer with Upright cart
Includes items 201 to 204

Model 231–085 Sprayer with Lo-Boy cart
Includes items 202 to 205

Ref No.	Part No.	Description	Qty
201	220–886	GM5000 Upright Basic Sprayer See parts list on page 37	1
202	223–541	HOSE, grounded, nylon; 1/4" ID; cpld 1/4 npsm(fbe); 50 ft (15 m); spring guards both ends	1
203	214–701	HOSE, grounded, nylon; 3/16" ID; cpld 1/4 npsm(m) x 1/4 npsm(f) swivel; 3 ft (0.9 m); spring guards both ends	1
204	220–955	"CONTRACTOR" SPRAY GUN Includes RAC IV™ DripLess™ Tip Guard and 517–size SwitchTip™ See 307–614 for parts	1
205	222–488	GM5000 Lo-Boy Basic Sprayer See parts list on page 39	1

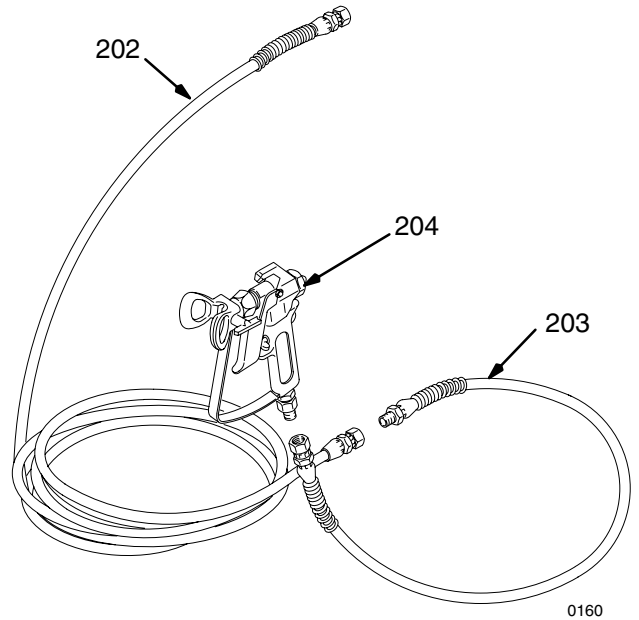

Parts – Pinion Assembly

Ref No. 19
Pinion Housing Assembly 220–920
Includes items 19a to 19m

Ref No.	Part No.	Description	Qty	Ref No.	Part No.	Description	Qty
19a	183–394	.HOUSING, pinion	1	19h**	108–798**	.BEARING, ball, large	1
19b	105–489	.PIN, dowel	2	19j**	183–396**	.HUB, armature	1
19c	108–692	.BEARING	1	19k	108–799	.RING, retaining, internal, large	1
19d	100–069	.BALL, sst	1	19m**	108–796**	.RING, retaining, small	1
19e	107–088	.BEARING	1				
19f**	108–797**	.BEARING, ball, small	1	<i>**Included in Repair Kit No. 221–032.</i>			
19g**	183–395**	.SHAFT, pinion	1				

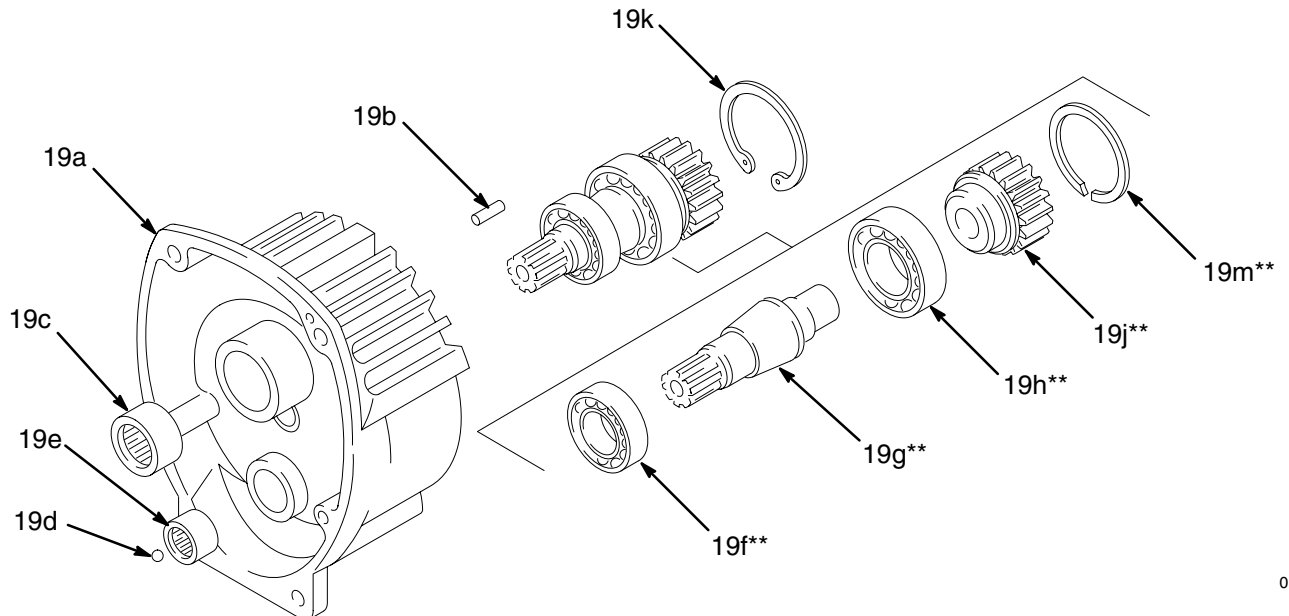

Parts – Basic Sprayer with Upright Cart

Model 220-886, Series C

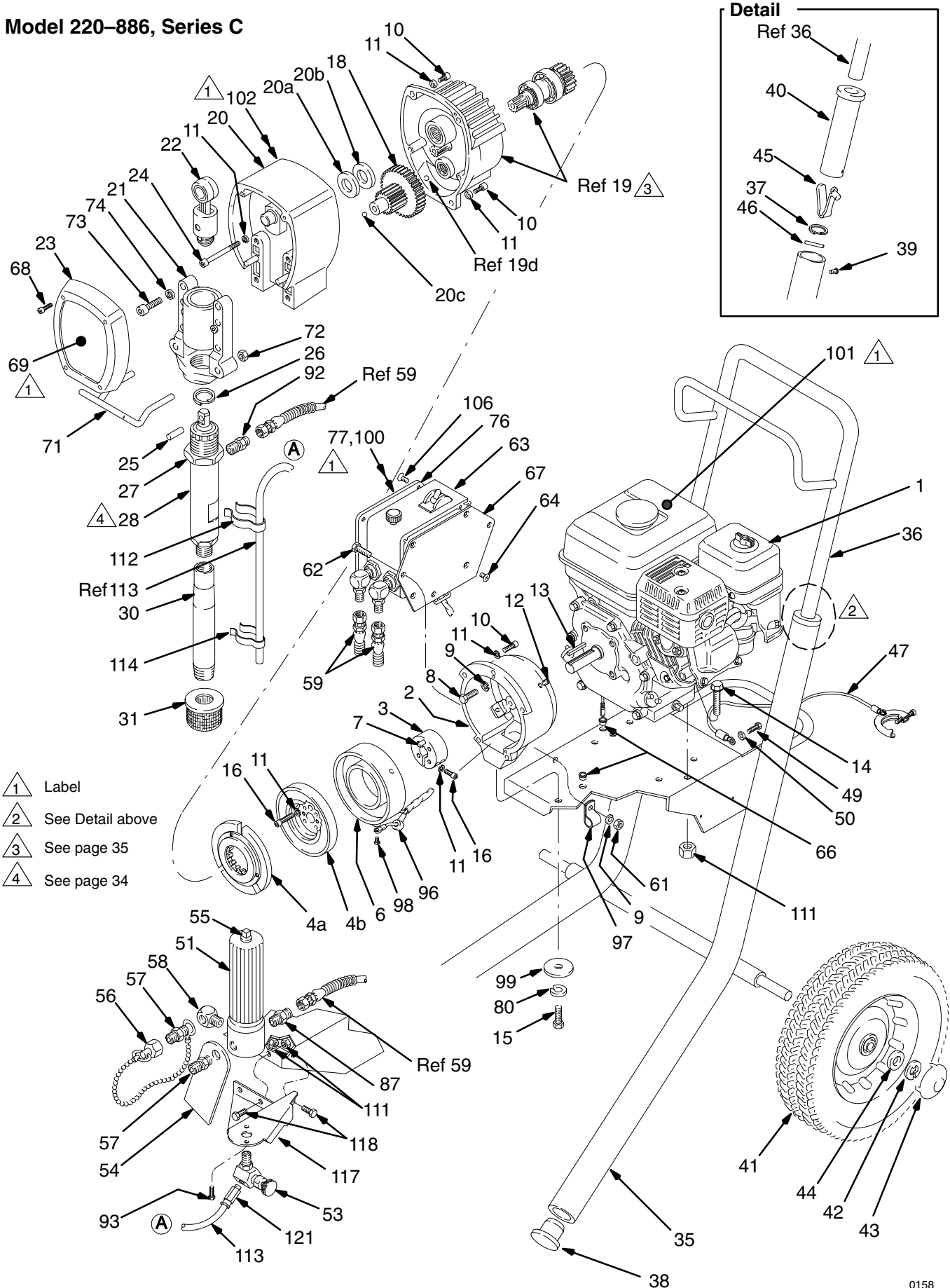

- 1 Label
- 2 See Detail above
- 3 See page 35
- 4 See page 34

Parts – Basic Sprayer with Upright Cart

Model 220–886, Series C

Ref No.	Part No.	Description	Qty	Ref No.	Part No.	Description	Qty
1	108–802	ENGINE, gasoline	1	51	214–570	FLUID FILTER	
2	183–397	HOUSING, clutch	1			See 307–273 for parts	1
3	183–517	CLAMP, mounting, rotor	1	53	224–775	VALVE, pressure drain	1
4	236–568	CLUTCH ASSEMBLY	1	54▲	178–034	TAG, warning	1
		Includes items 4a and 4b	1	55	100–040	PLUG, pipe, sq hd, 3/8 npt	1
4a		.ARMATURE	1	56	220–285	CAP	1
4b		.ROTOR	1	57	162–453	NIPPLE, hex, 1/4 npsm x 1/4 npt, 1–3/16" long	2
6	183–400	FIELD	1	58	100–840	ELBOW, street, 1/4–18 npt (m x f)	1
7	108–800	PIN, dowel, spring, 5/16 x 1"	1	59	220–849	HOSE, 3/8" ID, cpld 3/8 npsm (fbc), 29" (737 mm), spring guard both ends	2
8	108–842	CAPSCREW, hex hd, 5/16–24 x 3/4"	4			NUT, heavy hex, 5/16–18	3
9	100–214	LOCKWASHER, 5/16"	7			CAPSCREW, hex hd, 5/16–18 x 7/8"	3
10	100–644	CAPSCREW, socket head, 1/4–20 x 3/4"	9	61	100–188	PRESSURE CONTROL KIT	
			17	62	101–344	See page 40 for parts	1
11	105–510	LOCKWASHER, spring, 1/4"	4	63	222–369	SCREW, mach, flat head, thd frmg, 10–24 x 3/8" 4	
12	108–801	SETSCREW, 1/4–20	1	64	106–078	BUSHING, snap	2
13	183–401	KEY, parallel, 3/16" sq x 7/8"	1	66	108–805	BRACKET, mounting	1
14	110–837	FLANGE SCREW, hex hd, 5/16–18 x 1–1/2"	2	67	183–392	SCREW, mach, filh, 8–32 x 1–1/4"	4
15	100–469	CAPSCREW, hex hd, 3/8–16 x 3/4"	1	68	108–850	LABEL, identification	1
16	108–803	CAPSCREW, socket head, 1/4–28 x 1"	6	69	183–414	HANGER, pail	1
18	220–919	GEAR REDUCER	1	71	186–227	NUT, retainer	2
19	220–920	PINION HOUSING ASSEMBLY	1	72	110–814	CAPSCREW, socket head, 3/8–16 x 1–1/2"	4
		See parts on page 35	1	73	110–141	LOCKWASHER, spring, 3/8"	4
20	220–879	DRIVE HOUSING KIT	1	74	106–115	COVER, pressure control	1
		Includes items 20a to 20d	1	76	183–995	LABEL, identification, outside cover	1
20a	106–227	.WASHER, bronze	1	77	183–415	LOCKWASHER, spring, 3/8"	1
20b	183–209	.WASHER, silver	1	80	100–133	THROAT SEAL LIQUID, 8 oz (0.27 liter)	1
20c	100–069	.BALL, sst	1	86	206–994	NIPPLE, pipe, 3/8 npt(m) x 3/8 npsm(m)	1
20d	110–293	.TUBE, grease	1	87	162–485	NIPPLE, 3/8–18 npsm x 1/4–18 npt	1
21	220–639	BEARING HOUSING	1	92	183–461	FLANGE SCREW, hex hd, 1/4–20 x 5/8"	2
22	220–640	CONNECTING ROD	1	96	220–980	HARNES, wiring	1
23	183–168	COVER, housing	1	97	108–868	CLAMP, wire	2
24	108–849	CAPSCREW, socket head, 1/4–20 x 3"	2	98	108–860	SCREW, mach, bdgh, 8–32 x 1/4"	2
25	183–210	PIN, straight, 3/8 x 1/8"	1	99	108–851	WASHER, plain, 3/8"	1
26	183–169	SPRING, retaining	1	100▲	177–762	LABEL, Warning	1
27	183–170	NUT, hex, 1 13/16–16	1	101▲	181–867	LABEL, Warning	1
28	220–872	DISPLACEMENT PUMP	1	102▲	185–953	LABEL, Danger	1
		See page 34 for parts	1	106	110–037	SCREW, mach, pan head, thread forming, 10–24 x 1/2"	4
30	183–423	TUBE, intake	1	111	110–838	LOCKNUT, heavy hex, 5/16–18	5
31	181–072	STRAINER	1	112	186–490	CLIP, spring	1
35	236–788	CART FRAME	1	113	186–495	TUBE, bypass	1
36	220–918	CART HANDLE & HOSE RACK	1	114	181–102	CLIP, spring	1
37	183–350	WASHER, plain	2	117	186–638	BRACKET, filter mounting	1
38	108–794	PLUG, tubing	2	118	110–963	FLANGE SCREW, hex hd, 5/16–18 x 3/4"	3
39	108–795	SCREW, mach, pan head, 10–32 x 5/16"	4	121	108–982	CONNECTOR, tube	1
40	185–188	SLEEVE	2	122	187–189	NIPPLE, reducing	1
41	179–811	WHEEL, semi–pneumatic	2				
42	101–242	RING, retaining	2				
43	104–811	HUBCAP	2				
44	154–636	WASHER, 5/8"	4				
45	179–777	BUTTON, snap	2				
46	108–068	PIN, spring, straight, 3/16" x 11/4"	2				
47	222–011	GROUNDING CLAMP & WIRE	1				
49	100–078	SCREW, mach, hex washer head, No. 8 x 3/8"	1				
50	157–021	LOCKWASHER, internal, No. 8	1				

▲ Replacement Danger and Warning labels, tags and cards are available at no cost.

Parts – Basic Sprayer with Lo-Boy Cart

Model 222–488, Series A

Ref No.	Part No.	Description	Qty	Ref No.	Part No.	Description	Qty
1	108–802	ENGINE, gasoline	1	47	222–011	GROUNDING CLAMP & WIRE	1
2	183–397	HOUSING, clutch	1	49	100–078	SCREW, mach, hex washer hd, No. 8 x 3/8"	1
3	183–517	CLAMP, mounting, rotor	1	50	157–021	LOCKWASHER, internal, No. 8	1
4	236–568	CLUTCH ASSEMBLY Includes items 4a and 4b	1	51	214–570	FLUID FILTER	1
4a		.ARMATURE	1			See manual 307–273 for parts	1
4b		.ROTOR	1	53	222–198	VALVE, pressure drain	1
6	183–400	FIELD	1	54▲	178–034	TAG, warning	1
7	108–800	PIN, dowel, 5/16 x 1"	1	55	100–040	PLUG, pipe, sq hd, 3/8	1
8	108–842	CAPSCREW, hex hd, 5/16–24 x 3/4"	4	56	220–285	CAP	1
9	100–214	LOCKWASHER, 5/16"	9	57	162–453	NIPPLE, hex, 1/4 npsm x 1/4 npt, 1 3/16" long	2
10	100–644	CAPSCREW, socket head, 1/4–20 x 3/4"	13	58	100–840	ELBOW, street, 1/4–18 npt (m x f)	1
11	105–510	LOCKWASHER, spring, 1/4	17	59	222–516	HOSE, 3/8" ID, 2'4" long, cpld 3/8–18 npt(m) x 3/8 npsm(f) swivel; spring guards both ends	2
12	108–801	SETSCREW, 1/4–20"	4	62	100–001	CAPSCREW, hex hd, 5/16–18 x 5/8"	3
13	183–401	KEY, parallel, 3/16" sq x 7/8"	1	63	222–369	PRESSURE CONTROL KIT See page 40 for parts	1
14	110–837	FLANGE SCREW, hex hd, 5/16–18 x 1–1/2"	2	64	106–078	SCREW, mach, flat head, thread forming, 10–24 x 3/8"	4
15	100–469	CAPSCREW, hex hd, 3/8–16 x 3/4"	1	65	100–333	CAPSCREW, hex hd. 1/4–20 x 1/2"	4
16	108–803	CAPSCREW, socket head, 1/4–28 x 1.0"	6	66	109–099	BUSHING, snap	2
18	220–919	GEAR REDUCER	1	68	108–850	SCREW, mach, filh, 8–32 x 1.25"	4
19	220–920	PINION HOUSING ASSEMBLY See parts on page 35	1	69	183–414	LABEL, identification	1
20	220–879	DRIVE HOUSING KIT Includes items 20a to 20d	1	73	110–141	CAPSCREW, socket head, 3/8–16 x 1.5"	4
20a	106–227	.WASHER, bronze	1	74	106–115	LOCKWASHER, spring, 3/8"	4
20b	183–209	.WASHER, silver	1	76	183–995	COVER, pressure control	1
20c	100–069	.BALL, sst	1	77	183–415	LABEL, identification, outside cover	1
20d	110–293	.TUBE, grease	1	78	100–015	NUT, hex, 1/4–20	4
21	220–639	BEARING HOUSING	1	79	100–016	LOCKWASHER, spring, 1/4"	8
22	220–640	CONNECTING ROD	1	80	100–133	LOCKWASHER, spring, 3/8"	1
23	183–168	COVER, housing	1	86	206–994	THROAT SEAL LIQUID, 8 oz (0.27 liter)	1
24	108–849	CAPSCREW, socket head, 1/4–20 x 3"	2	87	162–485	NIPPLE, pipe, 3/8 npt(m) x 3/8 npsm(m)	1
25	183–210	PIN, straight, 3/8 x 1 1/8"	1	88	222–469	SUPPORT, foot	1
26	183–169	SPRING, retaining	1	92	183–461	NIPPLE, 3/8–18 npsm x 1/4–18 npt	1
27	183–170	NUT, hex, 1 13/16–16	1	93	110–997	FLANGE SCREW, hex head, 1/4–20 x 5/8	2
28	220–872	DISPLACEMENT PUMP See page 34 for parts	1	96	220–980	HARNESS, wiring	1
30	109–059	BUMPER	2	97	108–868	CLAMP, wire	1
31	222–517	SUCTION TUBE Includes items 31a to 31j	1	98	108–860	SCREW, mach, bdgh, 8–32 x 1/4"	2
31a	170–957	.TUBE, suction	1	99	108–851	WASHER, plain, 3/8"	1
31b	181–072	.STRAINER	1	100▲	177–762	LABEL, Warning	1
31c	110–964	.CLAMP, hose	2	101▲	181–867	LABEL, Warning	1
31d	110–960	.UNION, adapter	1	102▲	185–953	LABEL, Danger	1
31e	103–473	.STRAP, tie	2	106	110–037	SCREW, mach, pan head, thread frmng, 10–24 x 1/2"	4
31f	181–102	.CLIP, spring	2	107	183–765	BRACKET, mounting	1
31g	185–381	.HOSE, suction	1	108	109–078	BUSHING, strain relief	1
31h	805–077	.TUBE, bypass	1	111	110–838	LOCKNUT, heavy hex, 5/16–18	2
31j	176–450	.GUARD, HOSE	1				
35	222–612	CART	1				
41	179–811	WHEEL, semi–pneumatic	2				
42	101–242	RING, retaining	4				
43	104–811	HUBCAP	2				
44	154–636	WASHER, 5/8"	6				

▲ Replacement Danger and Warning labels, tags and cards are available at no cost.

Parts – Pressure Control

Part No. 222–369 – Basic Pressure Control for the GM5000 Sprayers

Includes items 300 to 313, 315, 325 and 326. Does not include items 314, 316 to 320.

For Upright Cart Sprayers,

Order the Basic Pressure Control 222–369, and item 314 and/or 316 to 318 as required

For Lo–Boy Cart Sprayers,

Order the Basic Pressure Control 222–369, and item 314 and/or 319 and 320 as required

Ref No.	Part No.	Description	Qty	Ref No.	Part No.	Description	Qty
300†	222–380	PRESSURE CONTROL Includes items 302 to 304	1	314	220–978	CONDUCTOR, red, white, black	1
301▲†	183–466	LABEL, warning	1	315†	100–035	SCREW, mach, slotted pan head; No. 8 x 5/16"	1
302†	105–679	ON/OFF SWITCH	1	316	183–461	NIPPLE, hex; 3/8–18 npsm x 1/4–18	2
303†	105–659	BOOT, switch	1	317	100–840	ELBOW, str, 1/4–18 npt (m x f)	2
304†	107–255	GUARD, locking	1	318	108–852	CONNECTOR, 45°	1
305†	157–021	LOCKWASHER, No. 8, internal	2	319	156–823	UNION, swivel, 1/4 npt (f) swivel x 1/4 npt(m)	1
306†	100–284	NUT, hex, msc 8–32	1	320	110–195	UNION, swivel, 45°	2
307†	108–219	RECTIFIER, bridge	1	325†	108–814	PLUG, pipe	1
308†	108–783	SCREW, mach, frhd 8–32 x 13/16"	1	326†	101–754	PLUG, pipe	1
309†	222–352	TRIAC ASSEMBLY	1				
310†	107–070	SCREW, flat head; csk hd	2				
311†	100–072	NUT, hex	2				
312†	103–181	LOCKWASHER	2				
313†	220–979	CONDUCTOR, red	2				

▲ Replacement Danger and Warning labels, tags and cards are available at no cost.

† Parts marked with a dagger are supplied with the basic pressure control. See Parts Drawing on page 41.

Wiring Schematic – Pressure Control

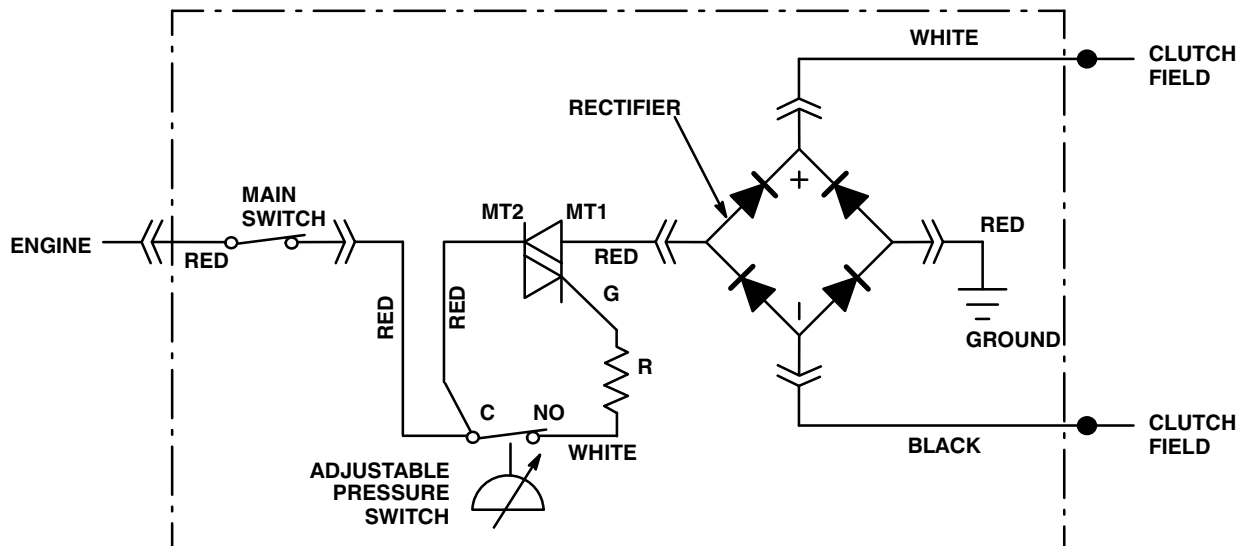

0054

Parts – Pressure Control

For Upright Cart Sprayers

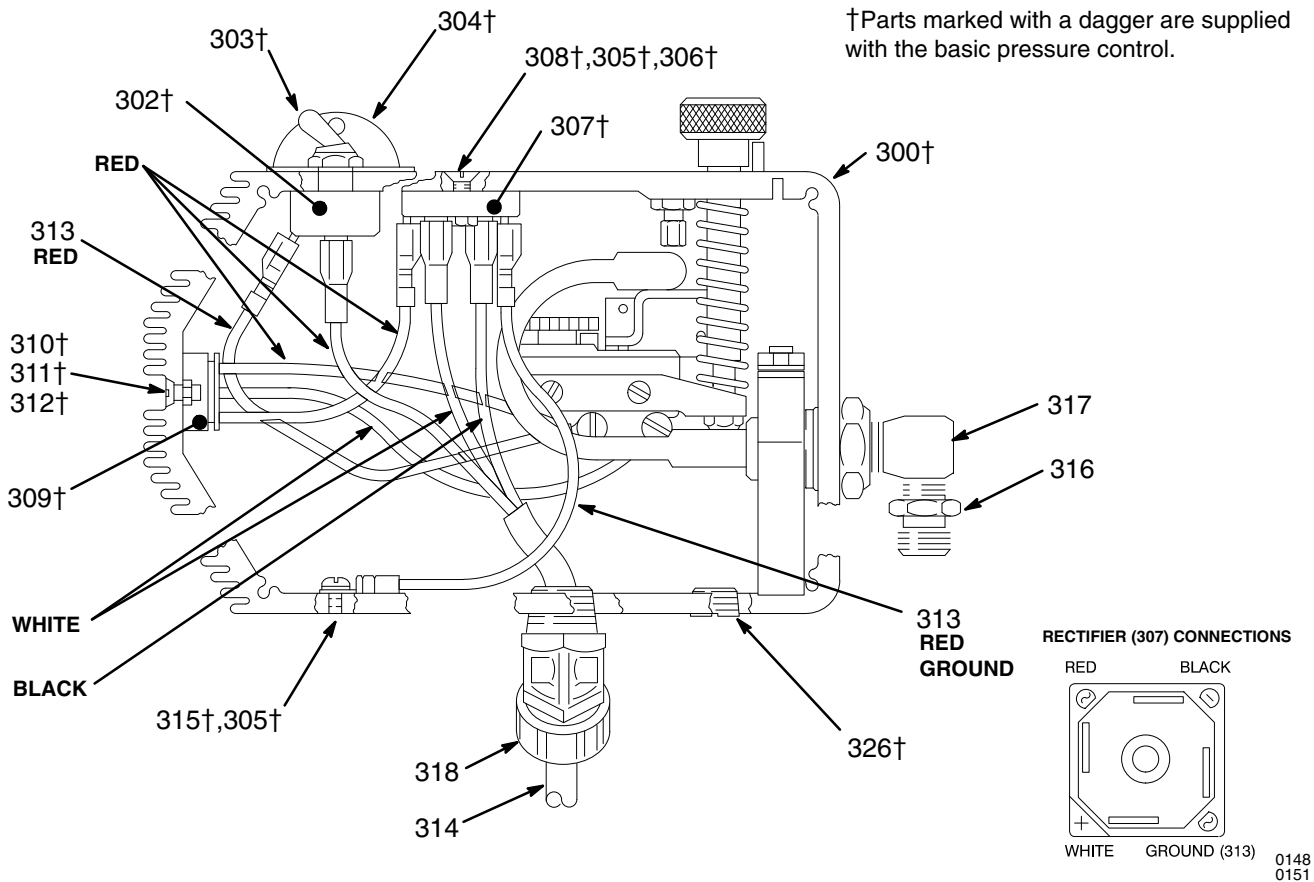

For Lo-boy Cart Sprayers

†Parts marked with a dagger are supplied with the basic pressure control.

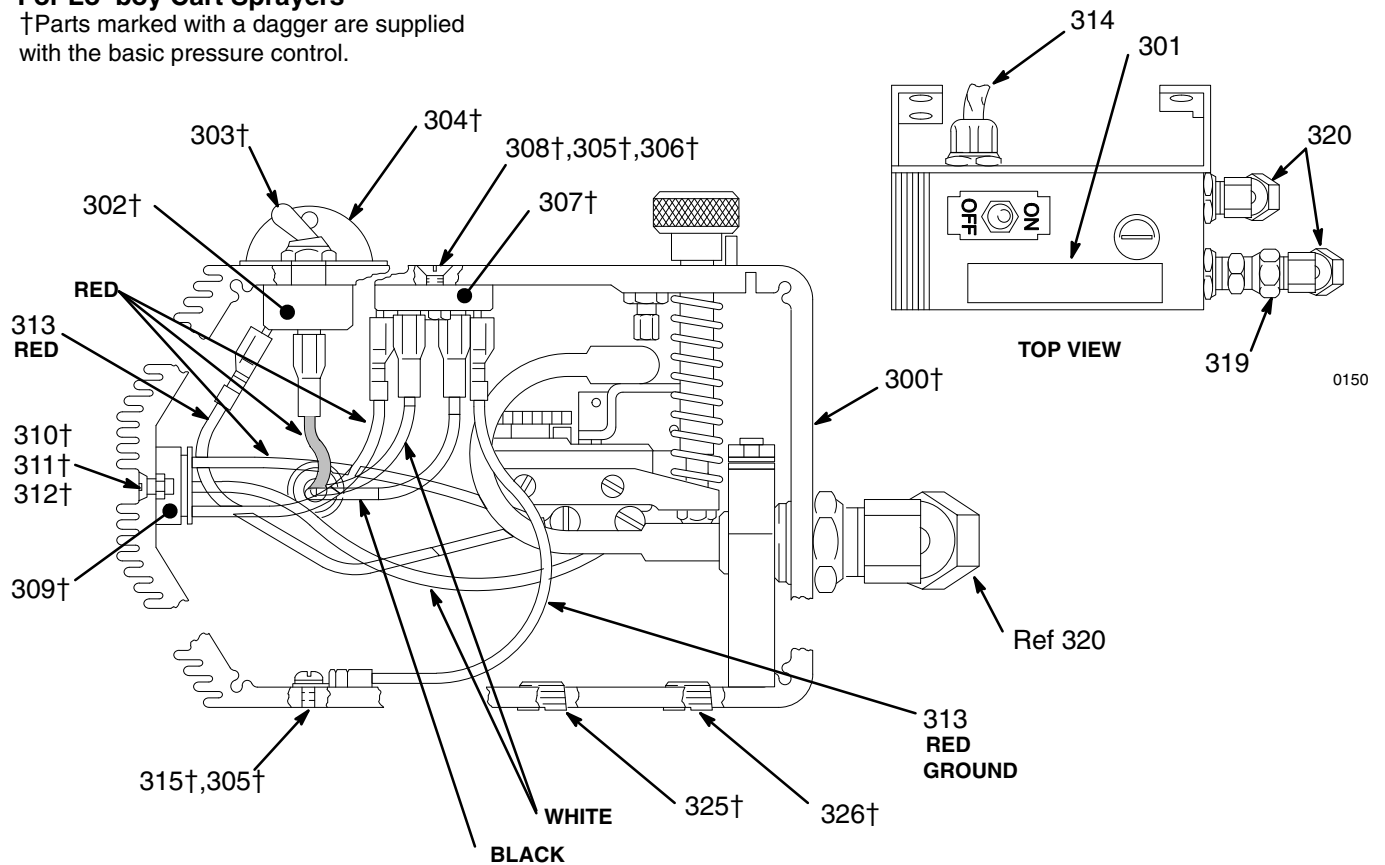

Accessories

USE ONLY GENUINE GRACO PARTS AND ACCESSORIES

DANGER LABELS

The English language DANGER label shown on page 1 is also on your sprayer. If you have painters who do not read English, order one of the following labels to apply to your sprayer. The drawing below shows the best placement of these labels for good visibility.

Order the labels directly from Graco, free of charge. Toll Free: 1-800-328-0211

Apply other language here

French 185-956
Spanish 185-961
German 186-041
Greek 186-045
Korean 186-049
English 185-593

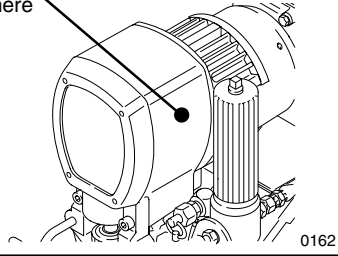

0162

5 Gallon (19 Liter) Suction Tube Kit 208-920

Includes:

Ref No.	Part No.	Description	Qty
1	101-818	CLAMP, hose	2
2	160-327	UNION, 90° swivel; 3/4 npt(m x f)	1
3	170-705	ADAPTER, intake	1
4	170-706	HOSE, 1" ID x 48"; nylon	1
5	170-957	TUBE, suction	1
6	181-072	STRAINER	1

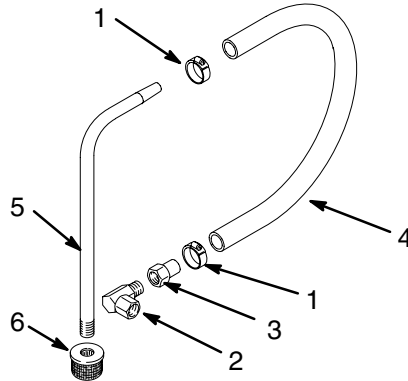

0161

Displacement Pump Repair Kit 220-877

Parts included in the kit are shown on page 34. Repair instructions are on page 31 of this manual and are also included with the kit.

Sleeve Removal Tool 224-788

Required for removing the displacement pump sleeve.

55 Gallon (200 Liter) Suction Tube Kit 208-259

Includes:

Ref No.	Part No.	Description	Qty
1	156-589	UNION, 90° ADAPTER, 3/4 npt(f) x 3/4 npsm(f) swivel	1
2	214-961	HOSE, coupled 3/4 npt(mbe) 3/4" ID; nylon, 6 ft (1.8 m); spring guard one end	1
3	156-591	ELBOW, 90°; 3/4 npt x 1-1/2 - 24 NS	1
4	156-593	PACKING, o-ring, nitrile rubber	1
5	100-220	THUMBSCREW, 5/16-18 x 1"	1
6	176-684	ADAPTER, bung	1
7	156-592	TUBE, riser	1
8	159-100	RETAINER, screen	1
9	161-377	SCREEN, filter	1
10	159-101	NUT, screen retainer	1

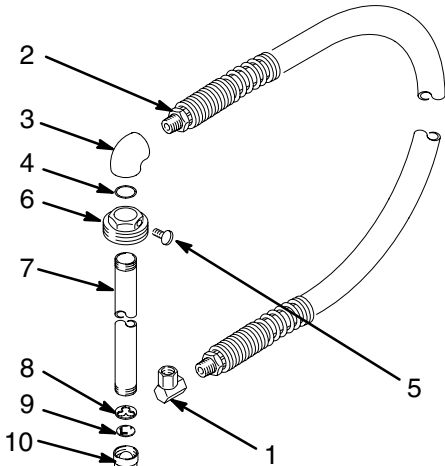

0162

Heavy Duty 5 Gallon (19 Liter) Suction Tube Kit 223-934

Includes:

Ref No.	Part No.	Description	Qty
1	183-770	STRAINER	1
2	110-962	SUCTION TUBE	1
3	110-964	HOSE CLAMP	2
4	186-245	SPRING CLIP	2
5	170-706	SUCTION HOSE	1
6	110-960	UNION	1
7	805-077	DRAIN TUBE	1
8	108-982	TUBE CONNECTOR	1
9	103-473	PLASTIC TIE	1
10	176-450	HOSE GUARD	1

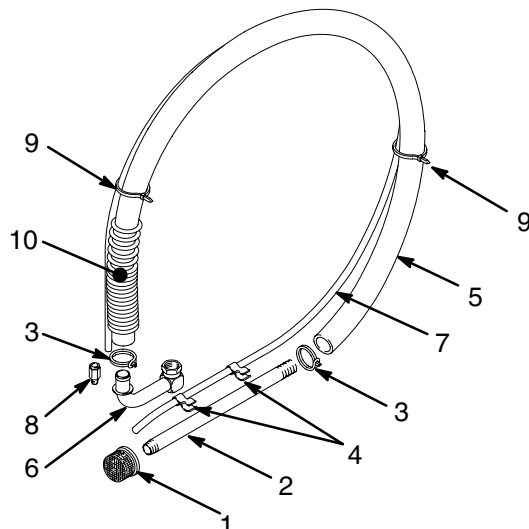

0164

The Graco Warranty and Disclaimers

WARRANTY

Graco warrants all equipment manufactured by it and bearing its name to be free from defects in material and workmanship on the date of sale by an authorized Graco distributor to the original purchaser for use. As purchaser's sole remedy for breach of this warranty, Graco will, for a period of twelve months from the date of sale, repair or replace any part of the equipment proven defective, with the exception of defects in parts on the drive train/gear box on EM and GM sprayers or power train on EH and GH sprayers, which will be repaired or replaced for twenty-four months from the date of sale for Gas-Hydraulic (GH) and Gas-Mechanical (GM) sprayers and for thirty-six months from the date of sale for Electric-Mechanical (EM), Electric-Hydraulic (EH), 390st and 490st sprayers. This warranty applies only when the equipment is installed, operated and maintained in accordance with Graco's written recommendations.

This warranty does not cover, and Graco shall not be liable for, any malfunction, damage or wear caused by faulty installation, misapplication, abrasion, corrosion, inadequate or improper maintenance, negligence, accident, tampering, or substitution of non-Graco component parts. Nor shall Graco be liable for malfunction, damage or wear caused by the incompatibility with Graco equipment of structures, accessories, equipment or materials not supplied by Graco, or the improper design, manufacture, installation, operation or maintenance of structures, accessories, equipment or materials not supplied by Graco.

This warranty is conditioned upon the prepaid return of the equipment claimed to be defective to an authorized Graco distributor for verification of the claim. If the claimed defect is verified, Graco will repair or replace free of charge any defective parts. The equipment will be returned to the original purchaser transportation prepaid. If inspection of the equipment does not disclose any defect in material or workmanship, repairs will be made at a reasonable charge, which charges may include the costs of parts, labor and transportation.

DISCLAIMERS AND LIMITATIONS

The terms of this warranty constitute purchaser's sole and exclusive remedy and are in lieu of any other warranties (express or implied), **including warranty of merchantability or warranty of fitness for a particular purpose**, and of any non-contractual liabilities, including product liabilities, based on negligence or strict liability. Every form of liability for direct, special or consequential damages or loss is expressly excluded and denied. In no case shall Graco's liability exceed the amount of the purchase price. Any action for breach of warranty must be brought within two (2) years of the date of sale.

EQUIPMENT NOT COVERED BY GRACO WARRANTY

Graco makes no warranty, and disclaims all implied **warranties of merchantability and fitness for a particular purpose**, with respect to accessories, equipment, materials, or components sold but not manufactured by Graco. These items sold, but not manufactured by Graco (such as electric motor, switches, hose, etc.) are subject to the warranty, if any, of their manufacturer. Graco will provide purchaser with reasonable assistance in making any claim for breach of these warranties.

Sales Offices: Atlanta, Chicago, Detroit, Los Angeles
Foreign Offices: Belgium, Canada, England, Korea, Switzerland, France, Germany, Hong Kong, Japan

GRACO INC. P.O. BOX 1441 MINNEAPOLIS, MN 55440-1441

PRINTED IN U.S.A. 307-847 June 1987, Revised November 1995

Parts Change Notice

Some parts in Rev. L of manual 307-847 have changed but have not yet been changed in the instruction manual. Please note the changes below and mark them in your manual or keep this sheet with your manual.

Assembly No.	Series Letter Change	Part That Changed	Ref No.	Part Description	Description of Change
Model 220-886 and 222-488	-	222-198	53	VALVE, pressure drain	Replaced by 237-677
		222-011	47	GROUNDING CLAMP & WIRE	Replaced by 237-686
		100-078	49	SCREW, mach, hex washer head, No. 8 x 3/8"	Replaced by 112-798
		157-021	50	LOCKWASHER, internal, No. 8	Deleted

Other Changes

Pages 36 and 38:

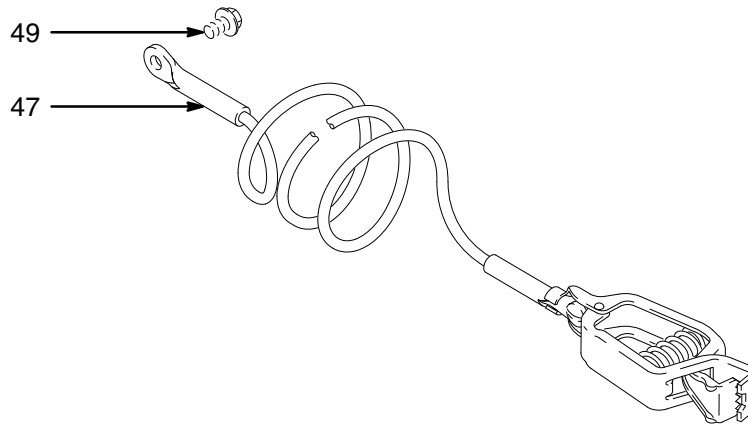

06489

- Upright Cart: Model 220-886, Basic sprayer
Model 231-052, Complete sprayer*
- LoBoy Cart: Model 222-488, Basic sprayer
Model 231-085, Complete sprayer*

Model 231-052 shown

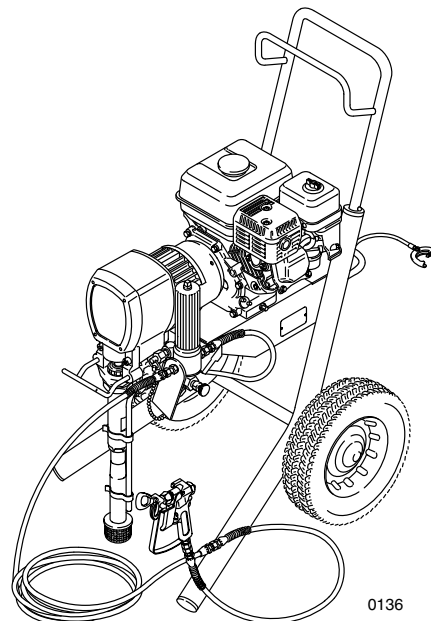

* Complete sprayers include 50 ft (15 m) 1/4 in. I.D. hose, 3 ft (0.9 m) 3/16" I.D. whip hose, and Contractor gun with RAC IV DripLess™ Tip Guard and 517 SwitchTip™

Technical Data

Maximum Working Pressure 3000 psi (210 bar)
Gasoline Engine 5.5 horsepower, Honda
Sound Data: Sound Power Level 105 dB(A)*
* measured at 3.1 ft. (1 m) per ISO 3744
Fuel Tank Capacity 0.95 gal (3.6 liter)
Delivery 1.25 gpm (4.7 lpm)
Cycles Per Gallon (Liter) 104 (27.5)
Tip Size 1 gun with 0.035 in. tip
2 guns with 0.025 in. tip
3 guns with 0.019 in. tip
with latex at 2000 psi (138 bar)
Pump Inlet Size 3/4 npt(m)
Inlet Paint Strainer 16 mesh (1190 micron)
reusable stainless steel screen
Fluid Filter Outlet Size 1/4 npsm(m)
Fluid Filter Material aluminum, stainless
steel, carbon steel, 60 mesh (250 micron)
reusable SST screen
Pump Material stainless steel, carbon steel
Delrin®, polyurethane

Packing Material leather, UHMW polyethylene
Spray Hose Requirements grounded,
50 ft (15 m) minimum, 1/4 in. I.D., non-wire
braid, spring guards on both ends

Application

Sprays a full range of architectural coatings, including heavy mastics. **Do not** use with solvents such as methylene chloride or other HHCs.

For information on converting your sprayer to one that can safely handle fluids containing HHCs, contact Graco Product Service at 1-800-328-0211.

U.S. patent pending.

Dimensions

	Upright Cart	LoBoy Cart
Height	31.6 in. (803 mm)	26.5 in. (673 mm)
Length	30.5 in. (775 mm)	36 in. (914 mm)
Width	22.5 in. (572 mm)	19 in. (483 mm)
Weight	135 lb (61 kg)	130 lb (58.5 kg)



GRACO INC. P.O. BOX 1441
MINNEAPOLIS, MN 55440-1441

©COPYRIGHT 1995, GRACO INC.
PRINTED IN U.S.A. 327-847 August 1995

TO PLACE AN ORDER, call
1-800-367-4023 Toll Free

FOR TECHNICAL ASSISTANCE, call
1-800-543-0339 Toll Free

Supplement to manual 307-847

GM5000 Airless Paint Sprayer

⚠ WARNING



INJECTION HAZARD

This is only a quick reference to the features and frequently ordered parts of this sprayer. To reduce the risk of serious injury, including fluid injection, while operating or repairing this sprayer, follow the warnings and instructions in manual 307-847.

Model 220-886, Series C

Basic sprayer with upright cart

Model 231-052

Complete sprayer with upright cart

Model 222-488, Series A

Basic sprayer with LoBoy cart

Model 231-085

Complete sprayer with LoBoy cart

Ref No.	Upright Part No.	LoBoy Part No.	Description
1	220-639	Same	Bearing Housing
2	220-640	Same	Connecting Rod
3	220-879	Same	Drive Housing
4	▲ 185-953	Same	Danger Label
5	220-919	Same	Gear Reducer
6	220-849	222-516	Hose
7	222-369	Same	Pressure Control
8	108-802	Same	Engine
9	220-918	None	Handle & Hose Rack
10	236-788	222-612	Cart Frame
11	224-775	222-198	Pressure Drain Valve
12	108-982	None	Tube Connector
13	214-570	Same	Fluid Filter
14	236-568	Same	Clutch Assembly
15	220-872	Same	Displacement Pump
15a	183-361	Same	.Cylinder Sleeve
15b	220-630	Same	.Piston Rod
15c	220-631	Same	.Piston Valve
15d	220-629	Same	.Intake Valve
16	183-423	170-957	Intake/Suction Tube
17	181-072	Same	Strainer
18	None	185-381	Suction Hose
19	186-495	805-077	Bypass Tube

▲ Extra danger labels are available for free.

Packing Repair Kit 220-877

Includes parts marked with a ★

Sleeve Removal Tool 224-788

Required for removing pump sleeve

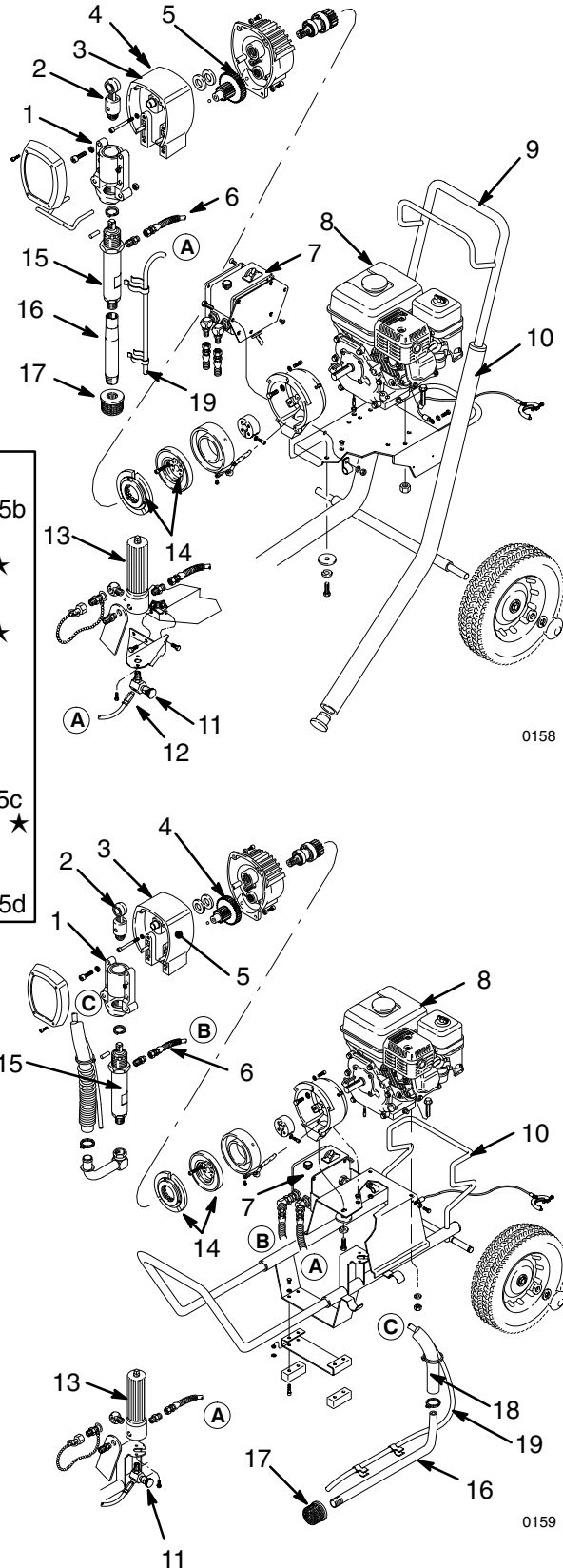
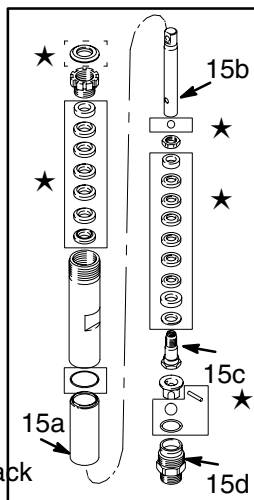

0158

0159