



INSTRUCTIONS

This manual contains important warnings and information.  
**READ AND KEEP FOR REFERENCE.**

*First choice when quality counts.™*

## LOW PRESSURE, MEDIUM VOLUME **HIGH-FLO® Pumps**

**NOTE: Stainless steel pumps are severe-duty and electropolished, for use with water-base coatings**

Refer to page 2 for the Table of Contents.

For Pump Model Nos., Ratios and Working Pressures, refer to page 3.

**NOTE: Refer to manual 307-837 for adapter kits for mounting the displacement pump to an existing motor.**

Patent Pending

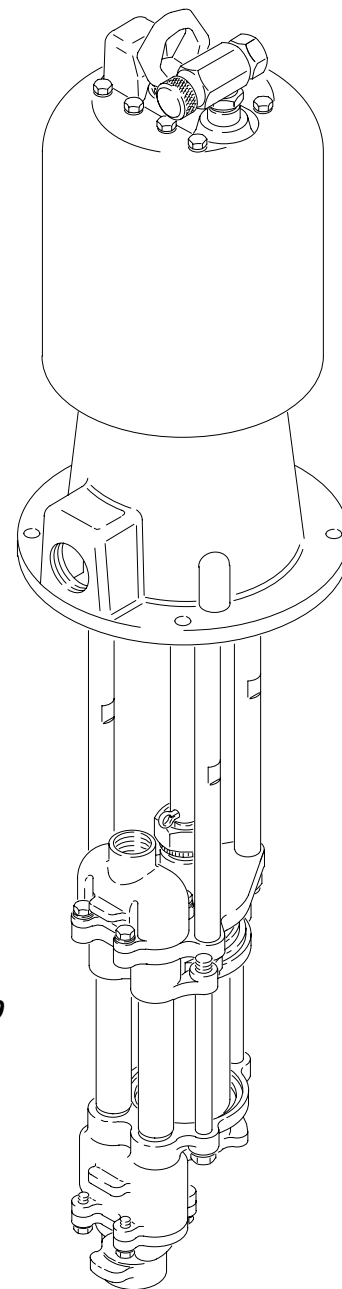

*Model 220-569  
Shown*

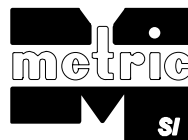

01921

# Table of Contents

Pump Models .....	3	Quiet Bulldog Pumps .....	27
Warnings .....	4	Viscount Pumps .....	29
Installation		Carbon Steel Displacement Pumps .....	30
All Pumps .....	7	Electropolished Stainless Steel	
Air-Powered Pumps .....	8	Displacement Pumps .....	32
Hydraulic-Powered Pumps .....	10	Repair Kits .....	34
Operation		Dimensions .....	35
All Pumps .....	12	Accessories .....	36
Air-Powered Pumps .....	13	Technical Data and Performance Charts	
Hydraulic-Powered Pumps .....	14	President Pumps .....	38
Maintenance .....	15	Senator Pumps .....	40
Troubleshooting .....	17	Bulldog Pumps .....	43
Service .....	18	Viscount Pumps .....	44
Parts		Warranty .....	46
President Pumps .....	24	Graco Phone Number .....	46
Quiet Senator Pumps .....	26		

# Pump Models

**NOTE:** These pumps are not suitable for metering. Contact your Graco distributor for more information.

## CARBON STEEL MODELS

Model No.	Series	Ratio and Type (parts list pages)	Maximum Air (or Hydraulic*) Working Pressure	Maximum Fluid Working Pressure
			MPa, bar (psi)	MPa, bar (psi)
220-559	A	1.5:1 President (24)	1.2, 12 (180)	1.9, 19 (270)
220-560	A	2:1 President (24)	1.2, 12 (180)	2.5, 25 (360)
220-561	A	3:1 President (24)	1.1, 11 (166)	3.4, 34 (500)
237-223	A	3:1 President, w/PTFE packings (24)	1.1, 11 (166)	3.4, 34 (500)
220-565	A	3.5:1 Quiet Senator (26)	0.7, 7.0 (100)	2.4, 24 (350)
220-566	A	5:1 Quiet Senator (26)	0.7, 7.0 (100)	3.4, 34 (500)
220-567	A	2.5:1 Quiet Senator (26)	0.7, 7.0 (100)	1.7, 17 (250)
220-577	A	4:1 Quiet Bulldog (27)	0.7, 7.0 (100)	2.8, 28 (400)
236-601	A	Viscount I+ (29)	10.3, 103 (1500)*	3.1, 31 (450)
236-605	A	Viscount I+ (29)	10.3, 103 (1500)*	2.1, 21 (300)
236-712	A	Viscount I+ (29)	10.3, 103 (1500)*	1.5, 15 (225)

## SEVERE-DUTY ELECTROPOLISHED STAINLESS STEEL MODELS

Model No.	Series	Ratio and Type (parts list pages)	Maximum Air (or Hydraulic*) Working Pressure	Maximum Fluid Working Pressure
			MPa, bar (psi)	MPa, bar (psi)
220-562	A	1.5:1 President (24)	1.2, 12 (180)	1.9, 19 (270)
220-563	A	2:1 President (24)	1.2, 12 (180)	2.5, 25 (360)
220-564	A	3:1 President (24)	1.1, 11 (166)	3.4, 34 (500)
239-819	A	3:1 President (24)	1.1, 11 (166)	3.4, 34 (500)
237-222	A	3:1 President, w/PTFE packings (24)	1.1, 11 (166)	3.4, 34 (500)
220-568	A	3.5:1 Quiet Senator (26)	0.7, 7.0 (100)	2.4, 24 (350)
220-569	A	5:1 Quiet Senator (26)	0.7, 7.0 (100)	3.4, 34 (500)
220-570	A	2.5:1 Quiet Senator (26)	0.7, 7.0 (100)	1.7, 17 (250)
220-578	A	4:1 Quiet Bulldog (27)	0.7, 7.0 (100)	2.8, 28 (400)
239-815	A	4:1 Quiet Bulldog (27)	0.7, 7.0 (100)	2.8, 28 (400)
236-602	A	Viscount I+ (29)	10.3, 103 (1500)*	3.1, 31 (450)
236-606	A	Viscount I+ (29)	10.3, 103 (1500)*	2.1, 21 (300)
236-713	A	Viscount I+ (29)	10.3, 103 (1500)*	1.5, 15 (225)

# Symbols

## Warning Symbol



This symbol alerts you to the possibility of serious injury or death if you do not follow the instructions.

## Caution Symbol



This symbol alerts you to the possibility of damage to or destruction of equipment if you do not follow the instructions.

## ! WARNING



INSTRUCTIONS

### EQUIPMENT MISUSE HAZARD

Equipment misuse can cause the equipment to rupture or malfunction and result in serious injury.

- This equipment is for professional use only.
- Read all instruction manuals, tags, and labels before operating the equipment.
- Use the equipment only for its intended purpose. If you are uncertain about usage, call your Graco distributor.
- Do not alter or modify this equipment. Use only genuine Graco parts and accessories.
- Check equipment daily. Repair or replace worn or damaged parts immediately.
- Do not exceed the maximum working pressure stated on the equipment or in the **Technical Data** for your equipment. Do not exceed the maximum working pressure of the lowest rated component in your system.
- Use fluids and solvents which are compatible with the equipment wetted parts. Refer to the **Technical Data** section of all equipment manuals. Read the fluid and solvent manufacturer's warnings.
- Do not use hoses to pull equipment.
- Route hoses away from traffic areas, sharp edges, moving parts, and hot surfaces. Do not expose Graco hoses to temperatures above 82°C (180°F) or below -40°C (-40°F).
- Wear hearing protection when operating this equipment.
- Do not lift pressurized equipment.
- Comply with all applicable local, state, and national fire, electrical, and safety regulations.



### MOVING PARTS HAZARD

Moving parts, such as the air motor piston, can pinch or amputate your fingers.

- Keep clear of all moving parts when starting or operating the pump.
- Before servicing the equipment, follow the **Pressure Relief Procedure** on page 12 to prevent the equipment from starting unexpectedly.

# WARNING



## FIRE AND EXPLOSION HAZARD

Improper grounding, poor ventilation, open flames or sparks can cause a hazardous condition and result in a fire or explosion and serious injury.

- Ground the equipment and the object being sprayed. Refer to **Grounding** on page 7.
- If there is any static sparking or you feel an electric shock while using this equipment, **stop spraying/dispensing immediately**. Do not use the equipment until you identify and correct the problem.
- Provide fresh air ventilation to avoid the buildup of flammable fumes from solvents or the fluid being sprayed/dispensed.
- Keep the spray/dispense area free of debris, including solvent, rags, and gasoline.
- Electrically disconnect all equipment in the spray/dispense area.
- Extinguish all open flames or pilot lights in the spray/dispense area.
- Do not smoke in the spray/dispense area.
- Do not turn on or off any light switch in the spray/dispense area while operating or if fumes are present.
- Do not operate a gasoline engine in the spray/dispense area.



## TOXIC FLUID HAZARD

Hazardous fluid or toxic fumes can cause serious injury or death if splashed in the eyes or on the skin, inhaled, or swallowed.

- Know the specific hazards of the fluid you are using.
- Store hazardous fluid in an approved container. Dispose of hazardous fluid according to all local, state and national guidelines.
- Always wear protective eyewear, gloves, clothing and respirator as recommended by the fluid and solvent manufacturer.



# Installation (All Pumps)

## Typical Installation

The Typical Installations shown in Figs. 2 and 3, and the following installation information are only guides. Proper sizing of the pump, accessories and lines is essential to get the maximum performance from your system. Contact your Graco distributor for assistance in designing a system to meet your needs.

## Mount the Pump

This pump can be mounted on a floor stand, cart, wall bracket, or drum. The floor stand shown in the Typical Installation is Part. No. 220-581.



Instructions for mounting the pump are supplied with the mounting accessory.

## Plumbing

The pump has a 1-1/2 in. npt(f) fluid inlet and a 1 in. npt(f) fluid outlet. Use a minimum 25 mm (1 in.) diameter pipe or hose between the pump outlet and any supply line accessories. Use a minimum 38 mm (1-1/2 in.) diameter pipe or hose between the mix tanks and pump inlet.

When using a stainless steel pump, use stainless steel plumbing to maintain a corrosion-resistant system.

## Grounding

 <b>WARNING</b>	
	<b>FIRE AND EXPLOSION HAZARD</b> Before operating the pump, ground the system as explained below. Also read the section <b>FIRE AND EXPLOSION HAZARD</b> on page 5.

1. *Pump*: use the ground wire and clamp. See Fig. 1. Loosen the grounding lug locknut (W) and washer (X). Insert one end of a 12 ga (1.5 mm<sup>2</sup>) minimum ground wire (Y) into the slot in lug (Z) and tighten the locknut securely. Connect the other end of the wire to a true earth ground. For a ground wire and clamp, order Part No. 237-569.

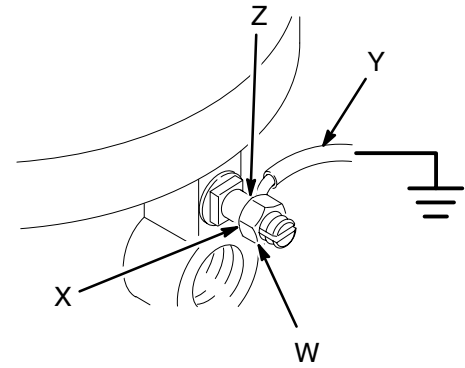

Fig. 1

0720

2. *Air and fluid hoses*: use only electrically conductive hoses.
3. *Air compressor or hydraulic power supply*: follow manufacturer's recommendations.
4. *Surge tank*: use a ground wire and clamp. See Fig. 1.
5. *Spray gun*: ground through connection to a properly grounded fluid hose and pump.
6. *Fluid supply container*: follow your local code.
7. *Object being sprayed*: follow your local code.
8. *Solvent pails used when flushing*: follow your local code. Use only metal pails, which are conductive, placed on a grounded surface. Do not place the pail on a nonconductive surface, such as paper or cardboard, which interrupts the grounding continuity.
9. *To maintain grounding continuity when flushing or relieving pressure*, hold a metal part of the spray gun firmly to the side of a grounded *metal* pail, then trigger the gun.

# Installation (Air-Powered Pumps)

## Air Line to Motor

### WARNING

A bleed-type master air valve (D) is required in your system, to help reduce the risk of serious injury including splashing fluid in the eyes or on the skin, and injury from moving parts if you are adjusting or repairing the pump.

The bleed-type master air valve relieves air trapped between this valve and the pump after the air is shut off. Trapped air can cause the pump to cycle unexpectedly. Locate the valve close to the pump. Order Part No. 113-333.

1. The air line lubricator (N) automatically lubricates the air motor to prevent corrosion. See Fig. 2.
2. The bleed-type master air valve (M) relieves air trapped between itself and the motor, when the valve is closed. Install one valve close to the pump, downstream from the air regulator. Install a second bleed valve upstream from all other air line accessories, to isolate the accessories for servicing.
3. The air regulator (L) controls pump speed.
4. The pump runaway valve (P) shuts off the air to the pump if the pump speed exceeds your pre-adjusted setting. Running a pump too fast can damage it.

5. The air filter (K) removes harmful dirt and moisture from the compressed air supply.
6. The air supply line (J) must be large enough to supply the proper volume of air to the motor.

## Fluid Line from Pump

### WARNING

A fluid drain valve (J) is required in your system, to help reduce the risk of serious injury including splashing in the eyes or on the skin if the pump cycles unexpectedly.

Locate one valve downstream from the pump outlet and another valve downstream from the surge tank (G). These drain valves are used to relieve fluid pressure in the pump and surge tank during shut-down.

1. The surge tank (G) reduces fluid surging to prevent backflow into the pump. Mounting instructions are supplied with the tank.
2. The shutoff valves (D) before and after the surge tank, and between each mix tank and the pump fluid inlet, isolate these components for servicing.
3. Be sure the supply line (C) between the pump and mix tanks is level.



# Installation (Air-Powered Pumps)

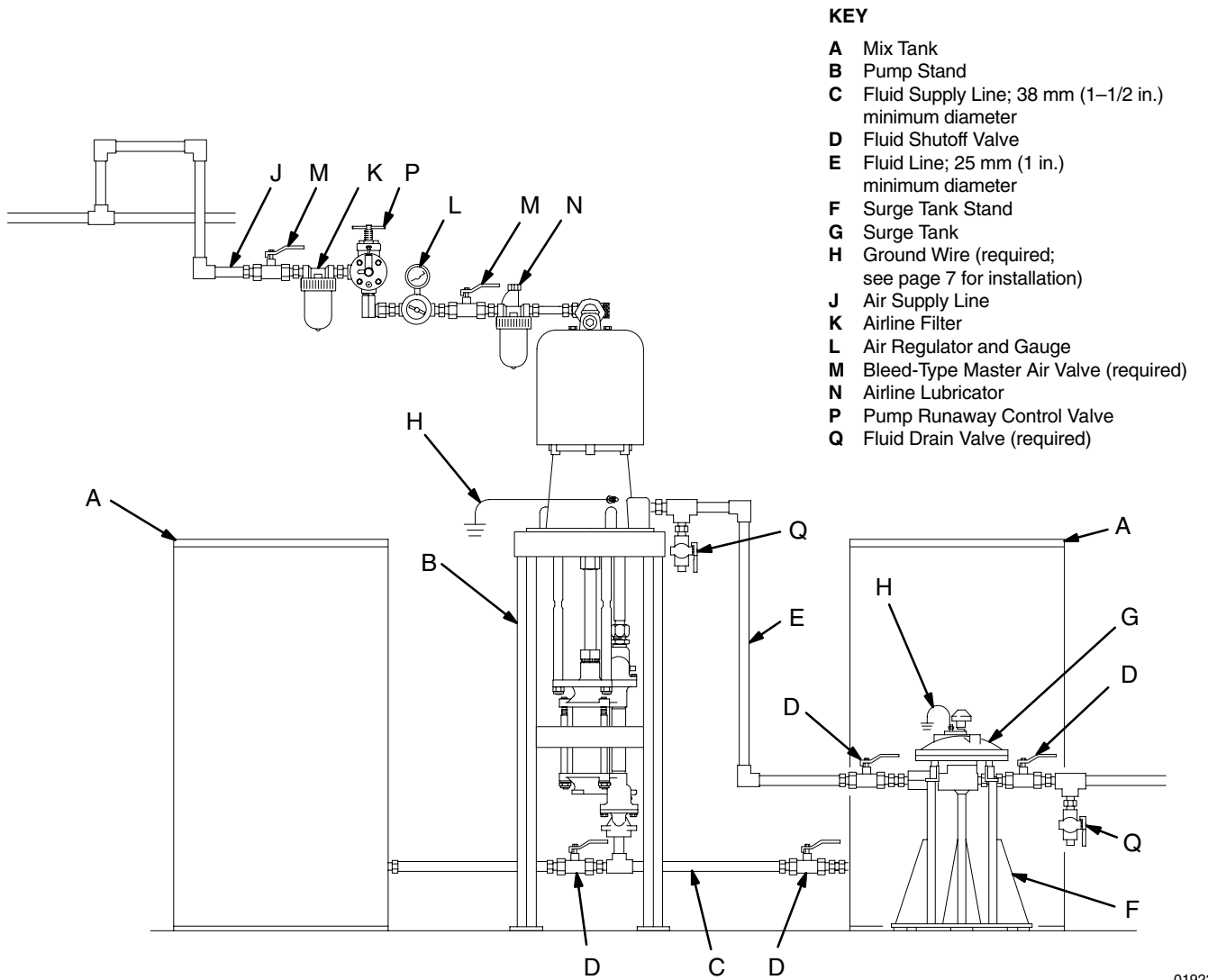

Fig. 2

01923

# Installation (Hydraulic-Powered Pumps)

## Hydraulic Power Supply

### CAUTION

The Hydraulic Power Supply must be kept clean at all times to avoid damage to the motor and hydraulic power supply.

1. Blow out hydraulic lines with air and flush thoroughly before connection to the motor.
2. Plug hydraulic inlets, outlets, and line ends when disconnecting them for any reason.

1. Be sure the power supply can provide sufficient power to the motor.
2. Be sure the power supply is equipped with a suction filter to the hydraulic pump.

## Hydraulic Supply to Motor

**NOTE:** The motor's hydraulic inlet is 3/4 in., 37° flare. Use a minimum 13 mm (1/2 in.) ID hydraulic supply line (L).

1. The shutoff valve (R) isolates the motor when servicing the system. See Fig. 3.
2. The hydraulic fluid pressure gauge (Q) monitors the hydraulic oil pressure to the motor. This helps avoid overpressurizing the motor or displacement pump.
3. The pressure- and temperature-compensated flow control valve (S) prevents the motor from running too fast, which can damage it.
4. The pressure reducing valve (P) which has a drain line (M) running to the return line (K), controls the hydraulic pressure to the motor.

## Hydraulic Return from Motor

**NOTE:** The motor's hydraulic outlet is 7/8 in., 37° flare. Use a minimum 16 mm (5/8 in.) ID hydraulic return line (K).

1. The shutoff valve (R) isolates the motor when servicing the system.

### CAUTION

To avoid damage to the pump, never use the return line shutoff valve to control the hydraulic flow. Do not install any flow control devices on the hydraulic return line.

2. The 10 micron size return filter (J) removes residue from the hydraulic fluid to help keep the system running smoothly.

## Fluid Line from Pump

### WARNING

A fluid drain valve (J) is required in your system, to help reduce the risk of serious injury including splashing in the eyes or on the skin if the pump cycles unexpectedly.

Locate one valve downstream from the pump outlet and another valve downstream from the surge tank (G). These drain valves are used to relieve fluid pressure in the pump and surge tank during shut-down.

1. The surge tank (G) reduces fluid surging to prevent backflow into the pump. Mounting instructions are supplied with the tank.
2. The shutoff valves (D) before and after the surge tank, and between each mix tank and the pump fluid inlet, isolate these components for servicing.
3. Be sure the supply line (C) between the pump and mix tanks is level.

# Installation (Hydraulic-Powered Pumps)

## KEY

- |  |  |  |                                       |
|--|--|--|---------------------------------------|
| <b>A</b> Mix Tank  | <b>E</b> Fluid Line; 25 mm (1 in.) minimum diameter          | <b>J</b> 10 Micron Return Filter                                 | <b>P</b> Pressure Reducing Valve      |
| <b>B</b> Pump Stand  | <b>F</b> Surge Tank Stand                                    | <b>K</b> Hydraulic Return Line; 16 mm (5/8 in.) minimum diameter | <b>Q</b> Hydraulic Pressure Gauge     |
| <b>C</b> Fluid Supply Line; 38 mm (1-1/2 in.) minimum diameter | <b>G</b> Surge Tank  | <b>L</b> Hydraulic Supply Line; 13 mm (1/2 in.) minimum diameter | <b>R</b> Hydraulic Shutoff Valve      |
| <b>D</b> Fluid Shutoff Valve                                   | <b>H</b> Ground Wire (required; see page 7 for installation) | <b>M</b> Drain Line  | <b>S</b> Flow Control Valve           |
|  |  |  | <b>T</b> Fluid Drain Valve (required) |

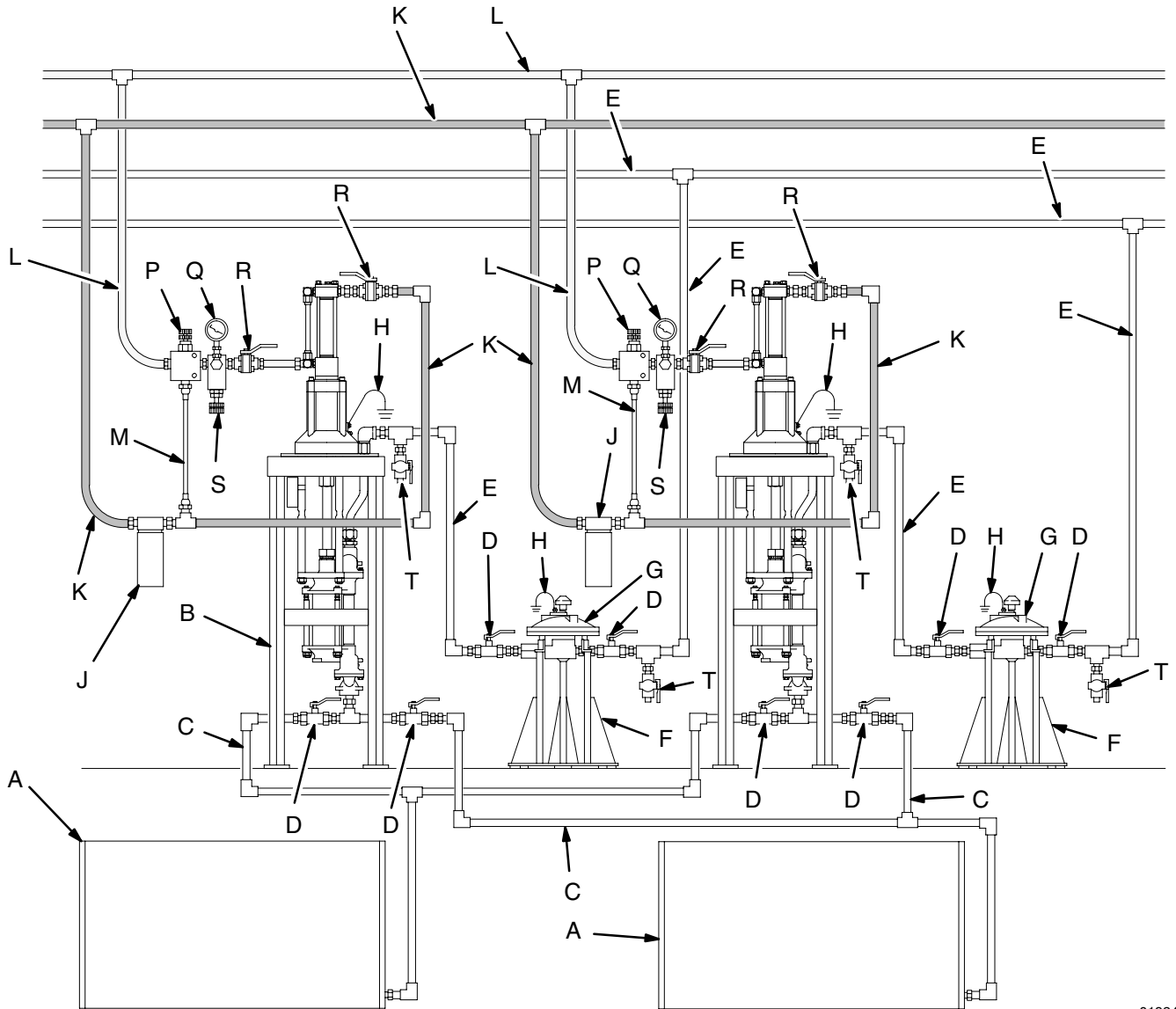

Fig. 3

01924

# Operation (All Pumps)

## Before You Start the Pump

Read and follow all instruction manuals, labels and tags supplied with this pump and with all the accessories you add to the system, before operating the system.

## Flush the Pump Before First Use

The pump was tested in lightweight oil. If the oil will contaminate the fluid you are pumping, flush it out with a compatible solvent.

## Pressure Relief Procedure

### **WARNING**

#### **PRESSURIZED EQUIPMENT HAZARD**

The system pressure must be manually relieved to prevent the system from starting or spraying accidentally. To reduce the risk of an injury from accidental spray from the gun, splashing fluid, or moving parts, follow the **Pressure Relief Procedure** whenever you:

- are instructed to relieve the pressure,
- stop spraying,
- check or service any of the system equipment,
- or install or clean the spray nozzle.

1. Shut off the power to the pump.
2. **In an air-powered system**, close the air regulator and close the bleed-type master air valve.
3. **In a hydraulic-powered system**, close the hydraulic supply line shutoff valve first, then the return line shutoff valve. In a multi-pump system, do this at each pump to isolate the pumps.
4. Close the fluid shutoff valves from the supply tanks.
5. Trigger the gun at the last gun station to relieve fluid pressure. Maintain firm metal-to-metal contact between the gun and a grounded waste pail. Repeat for all gun stations.
6. Open the pump drain valve to relieve fluid pressure which may be trapped in the pump or hose.

If you suspect that pressure is not fully relieved after following the steps above, wrap a fitting near the pump outlet with a rag, and slowly and carefully loosen the fitting to relieve pressure. Be careful to protect your eyes from splashing.

# Operation (Air-Powered Pumps)

## Starting and Adjusting the Pump

1. Charge the surge tank, if you are using one. See the separate instruction manual, 307–707.
2. Open all shutoff valves (D).
3. Open the dispensing valve/spray gun at the last gun station and keep it open while starting the pump.
4. Open the bleed-type master air valves (M).
5. Adjust the air regulator (L) to the minimum pressure necessary for the pump to cycle slowly.
6. When fluid is flowing smoothly from the gun, release the gun trigger.
7. One at a time, open any other guns in the system to purge air from the lines.
8. Adjust the pump runaway valve (P) according to the instructions supplied with it.
9. Adjust the lubricator (N) according to the instructions supplied with it.

**NOTE:** In a circulating system, the pump operates continuously until the power supply is shut off. In a direct supply system, the pump starts when the gun/valve is opened, and stops when the gun/valve is closed. The pump always stops on the downstroke due to the vented inlet seat (32).

## **WARNING**

### **COMPONENT RUPTURE HAZARD**



To reduce the risk of overpressurizing your system, which could cause component rupture and serious injury, *never exceed the specified maximum air input pressure to the pump* (see **Technical Data** on pages 38–43).

## Shutdown

## **WARNING**

To reduce the risk of serious injury whenever you are instructed to relieve pressure, always follow the **Pressure Relief Procedure** on page 12.

Relieve the pressure.

# Operation (Hydraulic-Powered Pumps)

## Starting and Adjusting the Pump

1. Charge the surge tank, if you are using one. See the separate instruction manual, 307–707.
2. Open all shutoff valves (D).
3. Turn on the hydraulic power supply.
4. Open the flow control valve (S) all the way.
5. Open the return line shutoff valve **first**, then open the supply line shutoff valve.
6. Open the dispensing valve/spray gun at the last gun station and keep it open while starting the pump.
7. Adjust the pressure reducing valve (P) until you get the desired fluid pressure.
8. When fluid is flowing smoothly from the gun, release the gun trigger.
9. One at a time, open any other guns in the system to purge air from the lines.
10. With a gun triggered open (dead-end systems only) or with the pump running in a circulating system, count the cycle rate of the pump for one minute. Close the flow control valve (S) until the cycle rate drops to below the desired cycle rate.
11. Open the flow control valve (S) slowly until the cycle rate and fluid pressure return to the desired level. This method of setting the hydraulic controls ensures proper pump operation and prevents pump runaway and damage if the fluid supply runs dry.

12. Release the gun trigger.

**NOTE:** In a circulating system, the pump operates continuously until the power supply is shut off. In a direct supply system, the pump starts when the gun/valve is opened, and stops when the gun/valve is closed. The pump always stops on the downstroke due to the vented inlet seat (32).

## WARNING



### COMPONENT RUPTURE HAZARD

To reduce the risk of overpressurizing your system, which could cause component rupture and serious injury, *never exceed the specified maximum hydraulic input pressure to the pump* (see **Technical Data** on page 44).

## Shutdown

## WARNING

To reduce the risk of serious injury whenever you are instructed to relieve pressure, always follow the **Pressure Relief Procedure** on page 12.

Relieve the pressure.

Always shut off the supply line shutoff valve **first**, and then the return line shutoff valve. This is to prevent overpressurizing the motor or its seals.

# Maintenance

The operating conditions of your particular system determine how often maintenance is required. Establish a good maintenance schedule during the first several weeks of operation by recording when and what kind of maintenance is needed, and then determine a regular schedule for checking your system. Your maintenance schedule should include the following:

## Flushing

**⚠ WARNING**

**FIRE AND EXPLOSION HAZARD**  
Before flushing, read the section **FIRE AND EXPLOSION HAZARD** on page 5. Be sure the entire system and flushing pails are properly grounded. Refer to **Grounding** on page 7.

1. Flush before shutting down the system for an extended period of time.
2. Flush before repairing the pump, if possible.
3. Flush before the fluid you are pumping can dry out, settle or set up in the pump and hoses.

## Packing Nut Tightness

The packing nut (21) should be tight enough to stop leakage, but no tighter. Overtightening compresses and damages the packings, and may cause the pump to leak, reducing performance. See Fig. 4.

To check the adjustment of the packing nut, first relieve fluid pressure. If you have a torque wrench, tighten the packing nut to 34–40 N•m (25–30 ft–lb).

## Excessive Leaking at Throat

To monitor leaking at the throat, remove one of the small plugs (31) from the packing nut (21). Place one end of a drain tube in the hole and the other end in a container. See Fig. 4. Monitor the drainage. If it seems excessive, and tightening the packing nut does not help, replace the throat packings. See page 20.

⚠ Torque to 34–40 N•m (25–30 ft–lb).

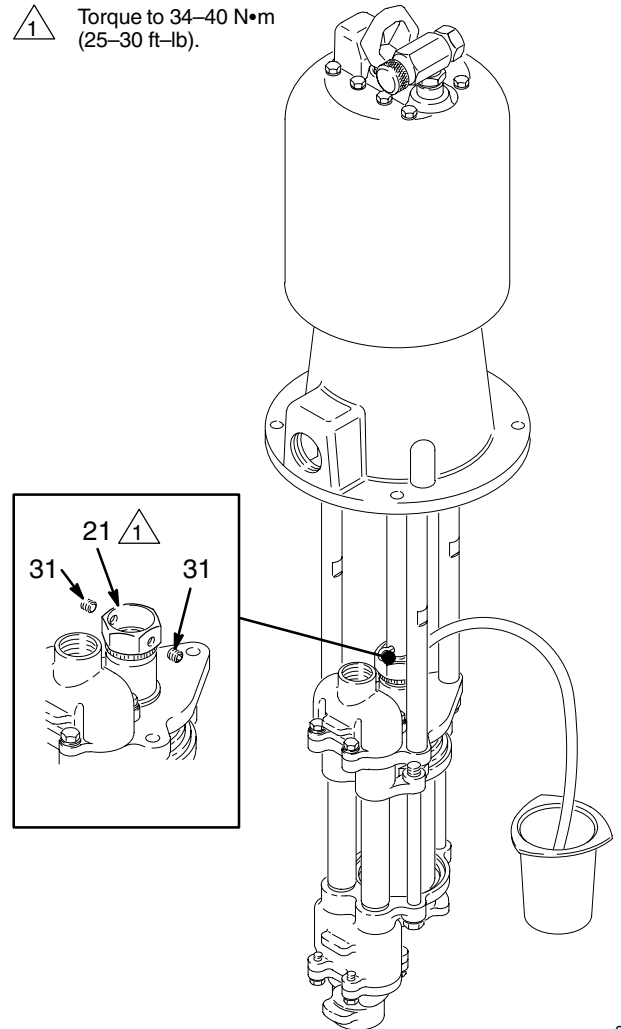

Fig. 4

01925

# Maintenance

## Air Line Lubricator

Keep properly filled for automatic air motor lubrication.

## Air Line Filter

Drain and clean as necessary.

## Hydraulic Power Supply Check

Carefully follow the hydraulic power supply manufacturer's recommendations on reservoir and filter cleaning, and periodic changes of hydraulic fluid.

## Mix Tank Volume

Don't let the mix tank run dry. When the tank is empty, the pump demands more power as it tries to suck in some fluid. This causes the pump to run too fast, which can seriously damage the pump.

## Stop the Pump at the Bottom of Its Stroke

### **WARNING**

To reduce the risk of serious injury whenever you are instructed to relieve pressure, always follow the **Pressure Relief Procedure** on page 12.

Whenever you stop the pump for any reason, relieve the pressure. Stop the pump on the downstroke, before the air motor changes over. If the pump is stopped on the upstroke a pressure relief seat causes the piston to creep until it reaches the up position. Following the **Pressure Relief Procedure** helps stop the pump at the bottom of its stroke.

### **CAUTION**

Failure to stop the pump at the bottom of its stroke allows fluid to dry on the piston rod, which can cause damage to the throat packings when the pump is restarted.



# Troubleshooting

## WARNING

To reduce the risk of serious injury whenever you are instructed to relieve pressure, always follow the **Pressure Relief Procedure** on page 12.

1. Relieve the pressure.
2. Check all possible problems and solutions before disassembling pump.

PROBLEM	CAUSE	SOLUTION
Pump output low on both strokes.	Restricted air or hydraulic supply lines.	Clear any obstructions; be sure all shut-off valves are open; increase pressure, but do not exceed maximum working pressure.
	Exhausted fluid supply.	Refill and reprime pump.
	Clogged fluid outlet line, valves, etc.	Clear.
	Worn piston packing (15).	Replace. See page 20.
Pump output low on only one stroke.	Held open or worn check valve.	Check and repair.
	Worn piston packing (15).	Replace. See page 20.
Pump operates erratically.	Exhausted fluid supply.	Refill and reprime pump.
	Held open or worn check valves.	Check and repair.
	Worn piston packing (15).	Replace. See page 20.
	Excessive hydraulic fluid supply pressure to Viscount motor.	See Viscount motor manual.
Pump will not operate.	Restricted air or hydraulic supply lines.	Clear any obstructions; be sure all shut-off valves are open; increase pressure, but do not exceed maximum working pressure.
	Exhausted fluid supply.	Refill and reprime pump.
	Clogged fluid outlet line, valves, etc.	Clear.
	Damaged air motor or hydraulic motor.	See motor manual.
	Fluid dried on piston rod (17).	Disassemble and clean pump (see page 20). In future, stop pump at bottom of stroke.
Pump will not prime.	Suction line clogged.	Clear. Flush more frequently.
	Held open or worn check valves.	Check and repair.
	Piston assembled with wrong nut.	Use only the large, round, special nut (12).
Excessive throat leakage.	Worn piston rod (17) or throat packings.	Replace. See page 20.

# Service

## Disconnecting the Displacement Pump

**NOTE:** In stand or wall-mounted installations, you do not have to remove the entire pump from its mounting.

### **WARNING**

To reduce the risk of serious injury whenever you are instructed to relieve pressure, always follow the **Pressure Relief Procedure** on page 12.

1. Relieve the pressure.
2. Disconnect the hoses from the displacement pump and plug the ends to prevent fluid contamination.
3. Disconnect the displacement pump from the motor as follows:

#### **For Senator and Bulldog air-powered pumps:**

Unscrew the coupling nut (A). Unscrew the locknuts (B) from the tie rods (C). Pull the displacement pump (D) off the motor (E). Remove the pin (F) and screw the coupling (G) off the piston rod (H). See Fig. 5.

#### **For President air-powered pumps:**

Unscrew the coupling nut (K) of the coupling rod (G) from the piston rod (H). Unscrew the locknuts (B) from the tie rods (C). Pull the displacement pump (D) off the motor (E). See Fig. 6.

#### **For Viscount hydraulic-powered pumps:**

Unscrew the coupling nut (K) of the coupling rod (G) from the piston rod (H). Unscrew the locknuts (B) from the tie rods (C). Pull the displacement pump (D) off the motor (E). See Fig. 7.

## Reconnecting the Displacement Pump

1. Reconnect the displacement pump to the motor as follows:

#### **For Senator and Bulldog air-powered pumps:**

Make sure the o-ring (J) is in place in the coupling (G). Screw the coupling onto the piston rod (H) and install the pin (F). Orient the displacement pump (D) to the motor (E) as shown in Fig. 5. Position the displacement pump (D) on the tie rods (C). Lubricate the threads of the tie rods. Screw the locknuts (B) onto the tie rods loosely. Screw the coupling nut (A) onto the motor shaft and torque to 102–109 N•m (75–80 ft-lb). Torque the tie rod locknuts to 68–75 N•m (50–55 ft-lb).

**For President air-powered pumps:** Orient the displacement pump (D) to the motor (E) and

adapter plate (L) as shown in Fig. 6. Position the displacement pump (D) on the tie rods (C). Lubricate the threads of the tie rods. Screw the locknuts (B) onto the tie rods loosely. Screw the coupling nut (K) onto the piston rod (H) and torque to 102–109 N•m (75–80 ft-lb). Torque the tie rod locknuts to 68–75 N•m (50–55 ft-lb).

#### **For Viscount hydraulic-powered pumps:**

Orient the displacement pump (D) to the motor (E) and adapter plate (L) as shown in Fig. 7. Position the displacement pump (D) on the tie rods (C). Lubricate the threads of the tie rods. Screw the locknuts (B) onto the tie rods loosely. Screw the coupling nut (K) onto the piston rod (H) and torque to 102–109 N•m (75–80 ft-lb). Torque the tie rod locknuts to 68–75 N•m (50–55 ft-lb).

2. Flush and test the pump before reinstalling it in the system. Connect hoses for flushing. Flush the pump. While it is pressurized, check for smooth operation and leaks. Adjust or repair as necessary before reinstalling in the system. Reconnect the pump ground wire before operating.

## Reassembling a Motor with an Adapter Plate

If your motor has an adapter plate, use this procedure when reassembling the motor and pump, to ensure proper alignment of the motor shaft to the piston rod.

1. Loosen the screws (M) holding the adapter plate (L) to the motor (E). See Fig. 8.
2. Screw the tie rods (C) into the adapter plate (L) and torque to 68–75 N•m (50–55 ft-lb).  
*On Viscount I+ pumps, the tie rods will engage threaded holes in the base of the motor.*
3. Fill the cavity in the bottom of the motor shaft with grease. Screw the coupling (G) into the motor shaft until the pin holes align. Install the pin (F) in the **second hole** from the end of the coupling for President pumps, and in the **first hole** from the end of the coupling for Viscount pumps.
4. Align the tie rods (C) with the displacement pump and loosely install the locknuts (B).
5. Screw the coupling nut (K) onto the piston rod (H) and torque to 102–109 N•m (75–80 ft-lb).
6. Torque the screws (M) holding the adapter plate (L) to the motor (E) to 20–23 N•m (15–17 ft-lb). Torque the tie rod locknuts (B) to 68–75 N•m (50–55 ft-lb).

# Service

**Model 220-569  
Senator Pump  
Shown**

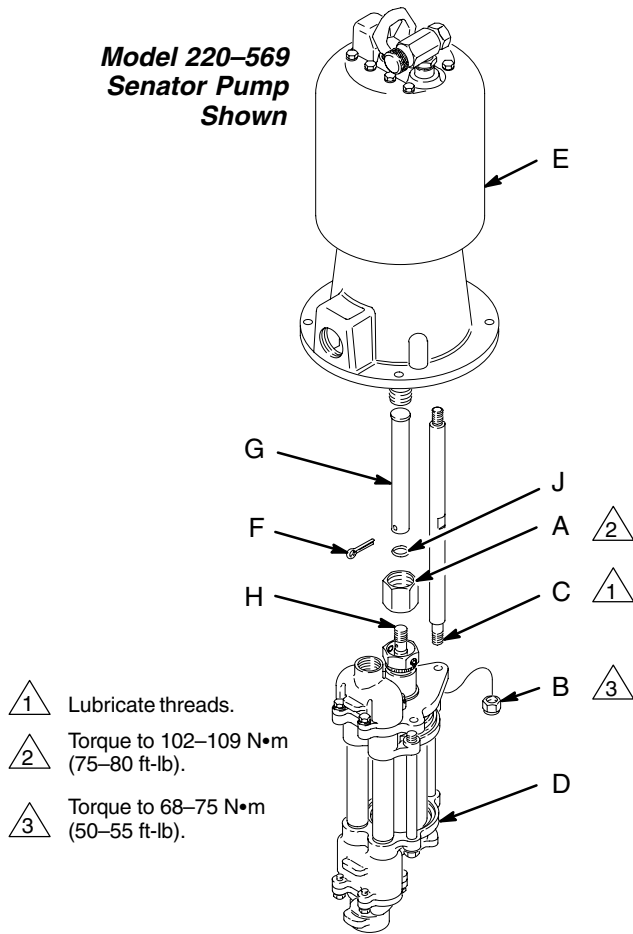

- 1 Lubricate threads.
- 2 Torque to 102-109 N•m (75-80 ft-lb).
- 3 Torque to 68-75 N•m (50-55 ft-lb).

01926

**Fig. 5**

**Model 220-564  
President Pump  
Shown**

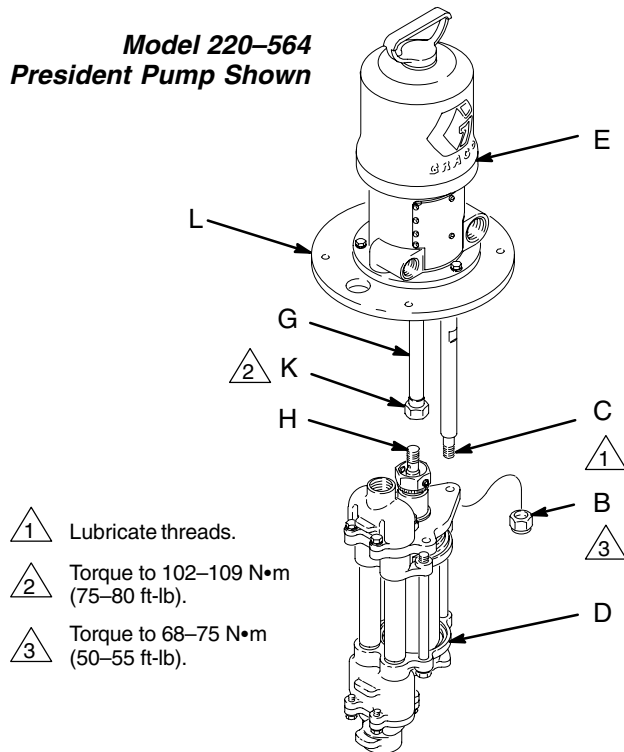

- 1 Lubricate threads.
- 2 Torque to 102-109 N•m (75-80 ft-lb).
- 3 Torque to 68-75 N•m (50-55 ft-lb).

01927

**Fig. 6**

**Model 236-601  
Viscount I+ Pump  
Shown**

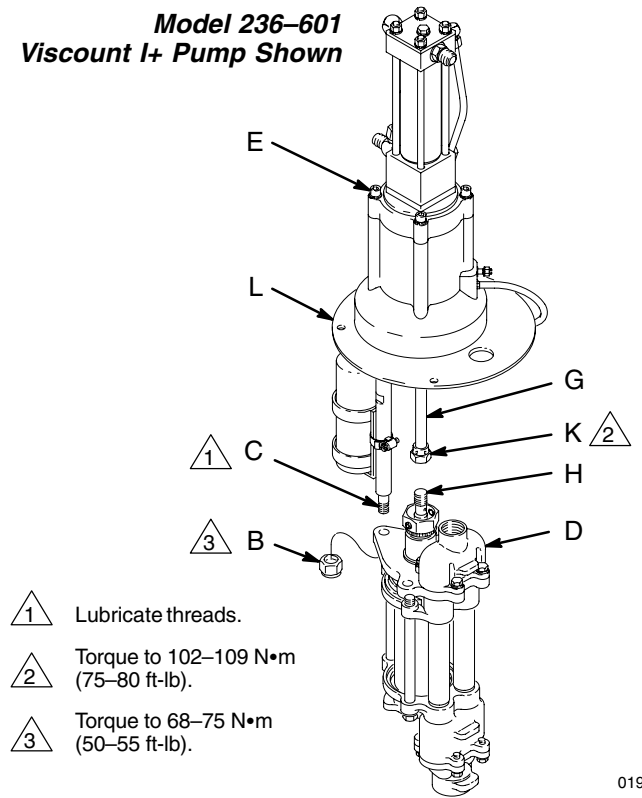

- 1 Lubricate threads.
- 2 Torque to 102-109 N•m (75-80 ft-lb).
- 3 Torque to 68-75 N•m (50-55 ft-lb).

01928

**Fig. 7**

**Model 220-564  
President Pump  
Shown**

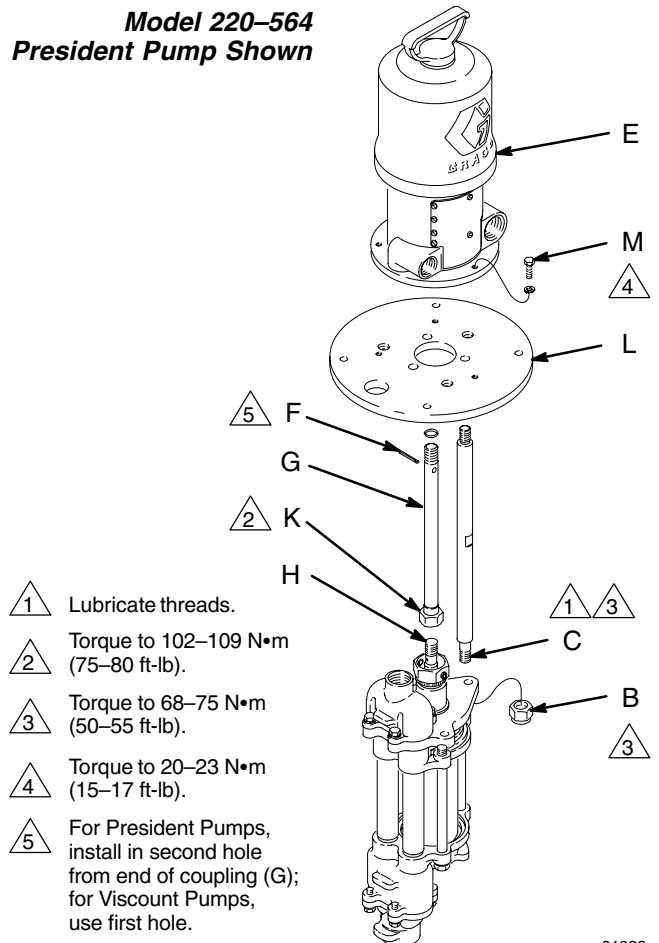

- 1 Lubricate threads.
- 2 Torque to 102-109 N•m (75-80 ft-lb).
- 3 Torque to 68-75 N•m (50-55 ft-lb).
- 4 Torque to 20-23 N•m (15-17 ft-lb).
- 5 For President Pumps, install in second hole from end of coupling (G); for Viscount Pumps, use first hole.

01929

**Fig. 8**

# Service

## Repair Kits

A pump seal kit is available for each pump size. Throat packing kits are also available, one for UHMWPE/leather pumps and one for PTFE pumps. The piston seals may also be converted to PTFE. Refer to page 34 for ordering.

Parts supplied in the pump seal kit are marked with one asterisk in the text and drawings, for example (2\*). Parts supplied in the throat packing kit are marked with a symbol, for example (19†). For the best results, use all the parts in the kit.

## Disassembling the Displacement Pump

1. Remove the pump from the motor as explained on page 18.
2. Secure the displacement pump intake housing (10) in a vise.
3. Refer to Fig. 9. Remove the four capscrews (9) and washers (8) from around the pump outlet housing (22).
4. Remove the outlet housing (22), balls (23), seats (24) and gaskets (7).
5. Remove the three tie bolts (13) and lockwashers (14). Lift off the upper pump housing (1), along with the fluid tubes (3), cylinder (4), and piston assembly (16).
6. Remove the packing nut (21), glands (19, 26) and packings (20, 25) from the upper housing (1).

**NOTE:** Model 237–220 and 237–221 displacement pumps use 5 PTFE v-packings in the throat, instead of 3 UHMWPE (20) and 2 leather (25).

7. Remove the tubes (3) and cylinder (4) from the housing.
8. Remove the intake housing (10) from the vise.

9. Remove the four capscrews (9) and washers (8) from the intake housing (10). Use a flatblade screwdriver inserted between the lower pump housing (11) and the intake housing (10) to separate the parts.

10. Remove the balls (5), seats (6 and 32) and gaskets (7).

**NOTE:** One of the seats (32) has a vent hole. Take note of the side of the pump in which this seat is used (the left side when viewed as shown in Fig. 9).

## WARNING

### COMPONENT RUPTURE HAZARD



The vented ball seat (32) must be installed at the fluid inlet. This valve relieves pressure trapped in the pump cylinder when the pump is shut off, and reduces the risk of pump overpressurization. The seat cannot relieve pressure if installed in any other position.

**NOTE:** Inspect the parts of the piston assembly (items 12, 15 and 16) in place before disassembling the piston. The piston seal (15) is included in the Seal Repair Kit. If it or any other parts of the piston show wear or damage, proceed to step 11. If no damage is apparent, it is not necessary to disassemble the piston.

11. Place the flats of the piston nut (12) in a vise. Unscrew the rod (17) from the nut. Disassemble the two halves of the piston (16) and remove the seal (15).

## Cleaning and Inspecting Parts

Clean all parts in a compatible solvent. Inspect all parts for wear or damage. If you are using a repair kit, use all the new parts in the kit, discarding the old ones they replace. Replace any other parts as needed. Worn or damaged parts may cause the pump to perform poorly or cause premature wear of the new seals and packings.

# Service

## Model 220–555 Severe-Duty Electropolished Stainless Steel Pump Shown

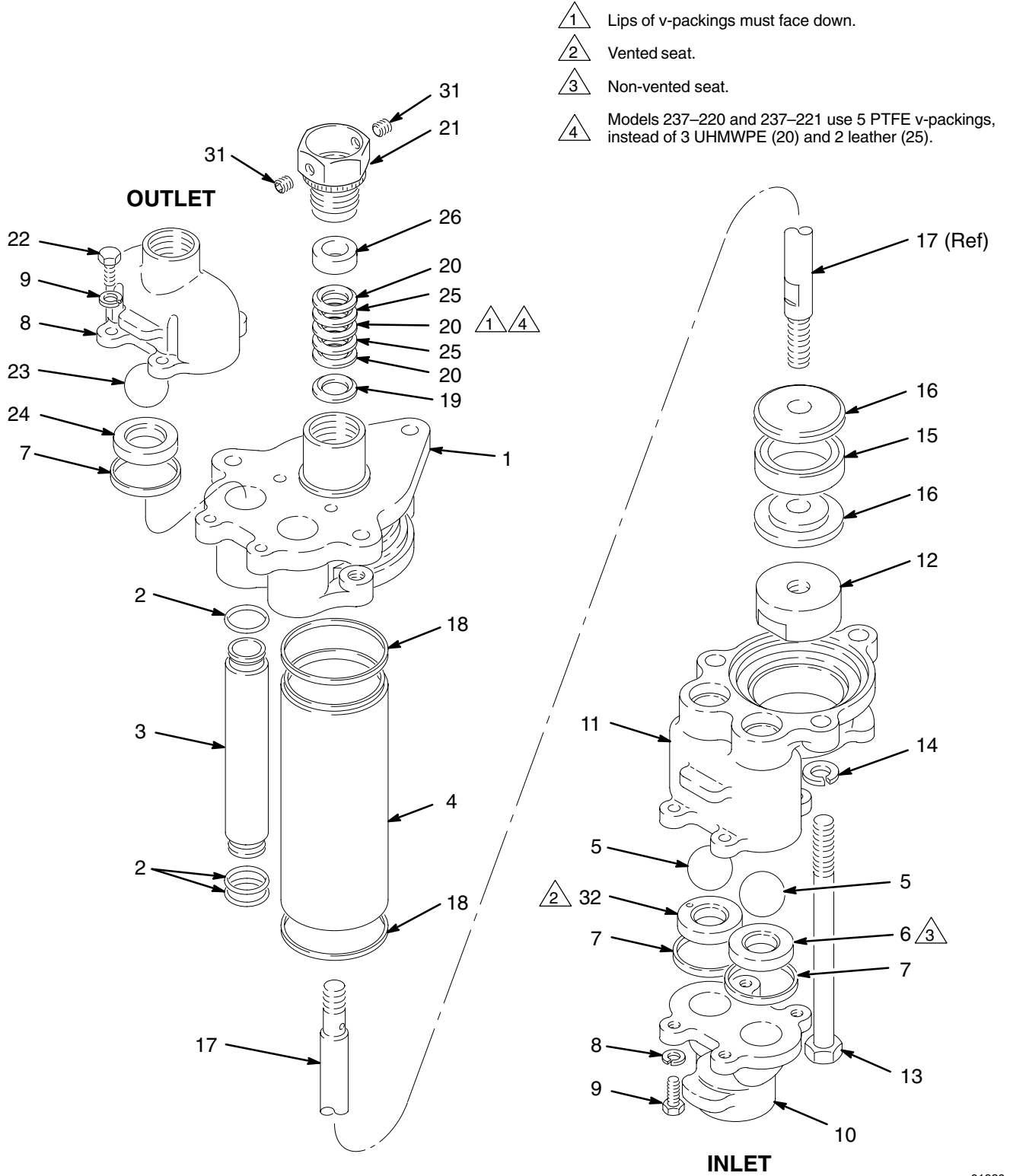

Fig. 9

01930

# Service

## Reassembling the Displacement Pump

**NOTE:** When thread sealant is specified, use low strength (blue) Loctite®.

1. Place the two halves of the piston (16) around the packing (15\*) and snap them together. See Fig. 10.
2. Apply thread sealant to the piston rod (17) threads. Screw the rod through the piston and packings and into the special piston nut (12). Torque the nut to 68–81 N•m (50–60 ft-lb).
3. With the lower pump housing (11) turned upside down, install the balls (5). Install the seats; place the vented seat (32) in the left side as viewed in Fig. 9 (housing has a label to identify the correct side), and the non-vented seat (6) in the right side. Install the gaskets (7\*).

**NOTE:** The seats (6 and 32) are not reversible; the chamfered side must face the ball.

4. Place the intake housing (10) on the lower pump housing (11). Install the lockwashers (8) and capscrews (9). Torque to 34–40 N•m (25–30 ft-lb). See Fig. 10.
5. Place the intake housing (10) in a vise. Place one o-ring (2\*) **in each side of the lower pump housing (11)** where the tubes (3) sit. Place another o-ring (2\*) **in the grooves at each end of the tubes**. Place a gasket (18\*) in both the upper and lower housings (1 and 11). Position the tubes and cylinder (4) in the lower housing (11).
6. Lubricate the inside of the cylinder (4). Slide the piston assembly into the cylinder.

7. **Lubricate the throat packings and glands.** Install them one at a time in the throat of the upper pump housing (1). Make sure the lips of the v-packings face down into the housing, and use a finger to seat the parts: the male gland (19†), one UHMWPE packing (20†), one leather packing (25†), UHMWPE, leather, UHMWPE, and the female gland (26†). Install the packing nut (21) finger-tight.

**NOTE:** Model 237–220 and 237–221 displacement pumps use 5 PTFE v-packings in the throat, instead of 3 UHMWPE (20) and 2 leather (25).

8. Install the upper pump housing (1). It may not seat well on the tubes and cylinder. Apply thread sealant to the threads of the three tie bolts (13). Install the bolts and lockwashers (14) from the lower pump housing (11). As you tighten the bolts into the upper housing (1), they will draw the housings firmly onto the tubes and cylinders. Tighten the bolts uniformly and torque to 34–40 N•m (25–30 ft-lb).
9. Torque the packing nut (21) to 68–74 N•m (50–55 ft-lb).
10. Place a ball (23), seat (24) and gasket (7\*) in each side of the outlet housing (22). Install the outlet housing on the upper pump housing (1). Note that the flatter side of the housing faces the **outside** edge of the pump. Install the lockwashers (8) and screws (9), and torque to 34–40 N•m (25–30 ft-lb).

### CAUTION

When installing the outlet adapters in the pump, be sure to hold the flats of both parts with wrenches. Overtightening the pump adapter into the outlet housing adapter may crack the housing.

11. Reconnect the displacement pump to the motor as explained on page 18.



# Parts (President Pumps)

## CARBON STEEL PUMPS

Model 220–559, Series A, 1.5:1 Ratio

Model 220–560, Series A, 2:1 Ratio

Model 220–561, Series A, 3:1 Ratio

Model 237–223, Series A, 3:1 Ratio

## SEVERE-DUTY, ELECTROPOLISHED STAINLESS STEEL PUMPS

Model 220–562, Series A, 1.5:1 Ratio

Model 220–563, Series A, 2:1 Ratio

Model 220–564, Series A, 3:1 Ratio

Model 239–819, Series A, 3:1 Ratio

Model 237–222, Series A, 3:1 Ratio

Ref No.	Part No.	Description	Qty	Ref No.	Part No.	Description	Qty
101	205–038	MOTOR, President; see 306–982	1	101	205–038	MOTOR, President; see 306–982	1
102	183–033	ROD, tie; 13.625" (346 mm) between shoulders	3	102	183–089	ROD, tie; 13.625" (346 mm) between shoulders	3
103	100–103	PIN, cotter; 1/8" dia x 1–1/2"	1	103	101–946	PIN, cotter; 1/8" dia x 1–1/2"	1
104	156–082	PACKING, o-ring; buna-N	1	104	156–082	PACKING, o-ring; buna-N	1
105	220–883	COUPLING	1	105	220–883	COUPLING	1
106	100–450	CAPSCREW, hex hd; 5/16–18 unc–2a x 1" long	3	106	100–450	CAPSCREW, hex hd; 5/16–18 unc–2a x 1" long	3
107	220–551	DISPLACEMENT PUMP for Model 220–559; see page 30	1	107	220–557	DISPLACEMENT PUMP for Model 220–562; see page 32	1
	220–549	DISPLACEMENT PUMP for Model 220–560; see page 30	1		220–555	DISPLACEMENT PUMP for Model 220–563; see page 32	1
	220–547	DISPLACEMENT PUMP for Model 220–561; see page 30	1		220–553	DISPLACEMENT PUMP for Model 220–564; see page 32	1
	237–221	DISPLACEMENT PUMP for Model 237–223; see page 30	1		239–820	DISPLACEMENT PUMP for Model 239–819; see page 32	1
					237–220	DISPLACEMENT PUMP for Model 237–222; see page 32	1
108	108–527	NUT, lock, hex; 9/16–12 unc	3	108	108–683	NUT, lock, hex; 9/16–12 unc	3
113	100–214	LOCKWASHER; 0.318"	3	113	100–214	LOCKWASHER; 0.318"	3
114	186–071	PLATE, adapter	1	114	186–071	PLATE, adapter	1
115	183–351	LABEL, ID (not shown)	1	115	183–351	LABEL, ID (not shown)	1



# Parts (President Pumps)

## CARBON STEEL PUMPS

Model 220-559, Series A, 1.5:1 Ratio

Model 220-560, Series A, 2:1 Ratio

Model 220-561, Series A, 3:1 Ratio

Model 237-223, Series A, 3:1 Ratio

## SEVERE-DUTY, ELECTROPOLISHED STAINLESS STEEL PUMPS

Model 220-562, Series A, 1.5:1 Ratio

Model 220-563, Series A, 2:1 Ratio

Model 220-564, Series A, 3:1 Ratio

Model 239-819, Series A, 3:1 Ratio

Model 237-222, Series A, 3:1 Ratio

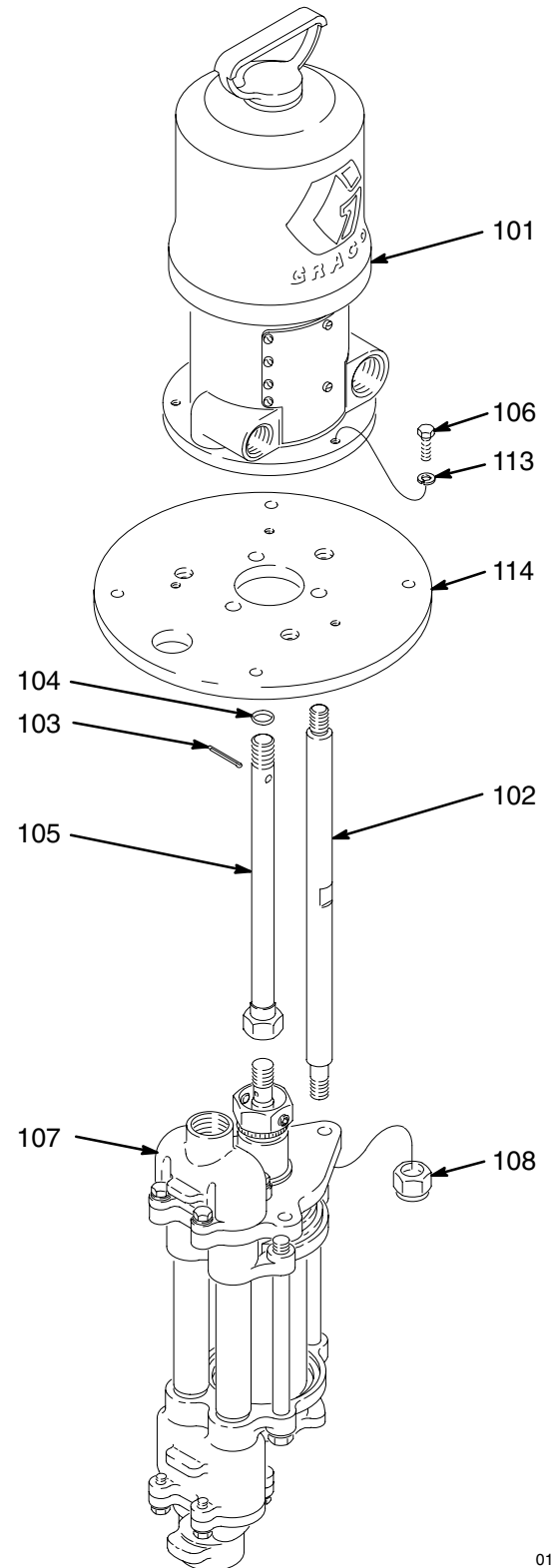

01929

# Parts (Quiet Senator Pumps)

## CARBON STEEL PUMPS

Model 220-565, Series A, 3.5:1 Ratio

Model 220-566, Series A, 5:1 Ratio

Model 220-567, Series A, 2.5:1 Ratio

Ref No.	Part No.	Description	Qty
101	220-571	MOTOR, Quiet Senator See 307-592 for parts	1
102	183-033	ROD, tie; 13.625" (346 mm) between shoulders	3
103	100-103	PIN, cotter; 1/8" dia x 1-1/2"	1
104	108-284	PACKING, o-ring; buna-N	1
105	183-041	COUPLING	1
106	183-042	NUT, coupling	1
107	220-549	DISPLACEMENT PUMP Used on Model 220-565 See separate parts list on page 30	1
	220-547	DISPLACEMENT PUMP Used on Model 220-566 See separate parts list on page 30	1
	220-551	DISPLACEMENT PUMP Used on Model 220-567 See separate parts list on page 30	1
108	108-527	NUT, lock, hex; 9/16-12 unc	3
113	181-096	LABEL, ID (not shown)	1

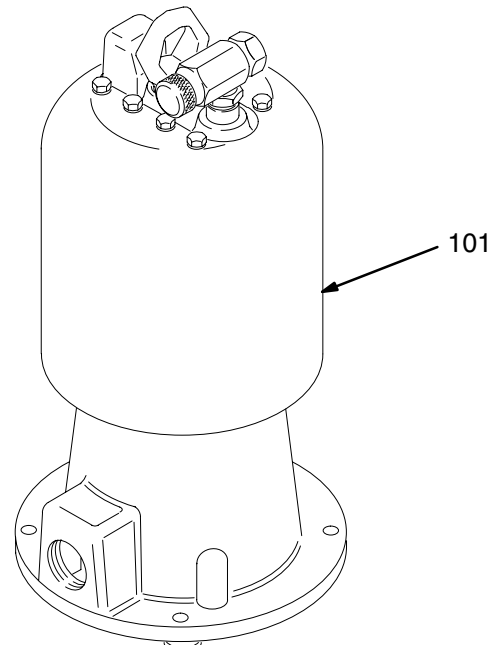

## SEVERE-DUTY, ELECTROPOLISHED STAINLESS STEEL PUMPS

Model 220-568, Series A, 3.5:1 Ratio

Model 220-569, Series A, 5:1 Ratio

Model 220-570, Series A, 2.5:1 Ratio

Ref No.	Part No.	Description	Qty
101	220-571	MOTOR, Quiet Senator See 307-592 for parts	1
102	183-089	ROD, tie; 13.625" (346 mm) between shoulders	3
103	101-946	PIN, cotter; 1/8" dia x 1-1/2"	1
104	108-284	PACKING, o-ring; buna-N	1
105	183-084	COUPLING	1
106	183-079	NUT, coupling	1
107	220-555	DISPLACEMENT PUMP Used on Model 220-568 See separate parts list on page 32	1
	220-553	DISPLACEMENT PUMP Used on Model 220-569 See separate parts list on page 32	1
	220-557	DISPLACEMENT PUMP Used on Model 220-570 See separate parts list on page 32	1
108	108-683	NUT, lock, hex; 9/16-12 unc	3
113	181-096	LABEL, ID (not shown)	1

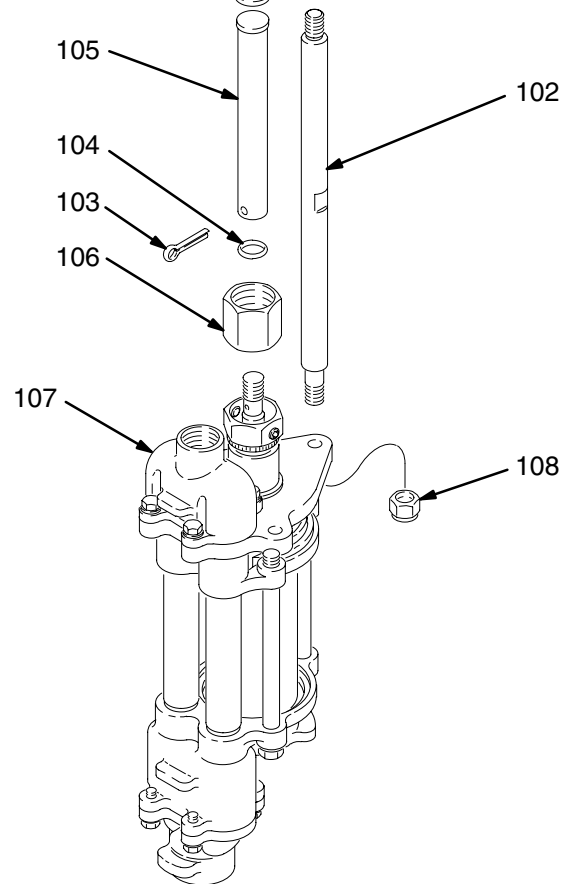

01926

# Parts (Quiet Bulldog Pumps)

## CARBON STEEL PUMPS

### Model 220-577, Series A, 4:1 Ratio

Ref No.	Part No.	Description	Qty
101	215-255	MOTOR, Quiet Bulldog See 307-304 for parts	1
102	183-033	ROD, tie; 13.625" (346 mm) between shoulders	3
103	100-103	PIN, cotter; 1/8" dia x 1-1/2"	1
104	108-284	PACKING, o-ring; buna-N	1
105	183-041	COUPLING	1
106	183-042	NUT, coupling	1
107	220-551	DISPLACEMENT PUMP See separate parts list on page 30	1
108	108-527	NUT, lock, hex; 9/16-12 unc	3
113	181-096	LABEL, ID (not shown)	1

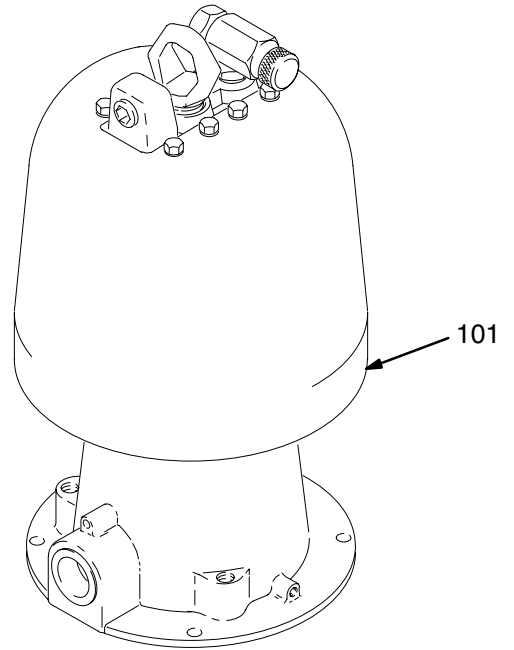

## SEVERE-DUTY, ELECTROPOLISHED STAINLESS STEEL PUMPS

### Model 220-578, Series A , 4:1 Ratio

### Model 239-815, Series A , 4:1 Ratio

Ref No.	Part No.	Description	Qty
101	215-255	MOTOR, Quiet Bulldog See 307-304 for parts	1
102	183-089	ROD, tie; 13.625" (346 mm) between shoulders	3
103	101-946	PIN, cotter; 1/8" dia x 1-1/2"	1
104	108-284	PACKING, o-ring; buna-N	1
105	183-084	COUPLING	1
106	183-079	NUT, coupling	1
107	220-557	DISPLACEMENT PUMP for Model 220-578; See separate parts list on page 32	1
	239-816	DISPLACEMENT PUMP for Model 239-815; See separate parts list on page 32	1
108	108-683	NUT, lock, hex; 9/16-12 unc	3
113	181-096	LABEL, ID (not shown)	1

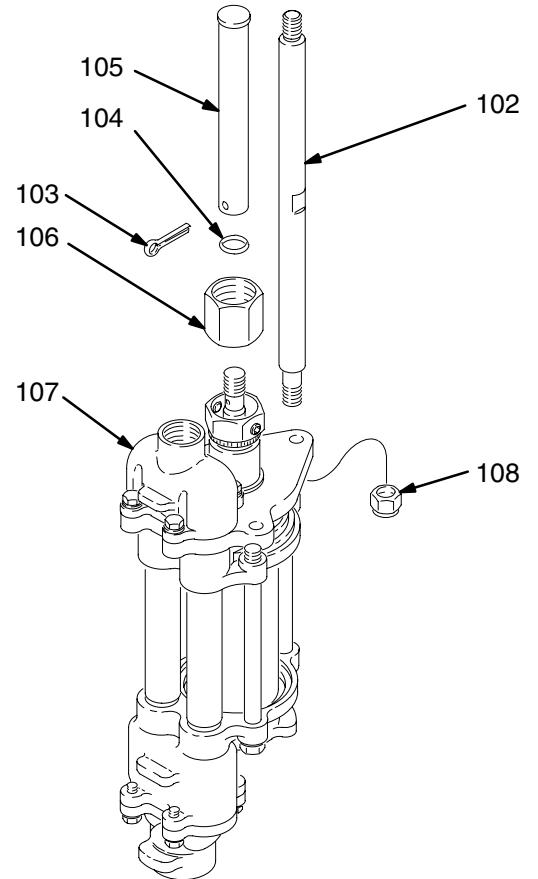

01934



# Parts (Viscount I+ Pumps)

## CARBON STEEL PUMPS

Model 236-601, Series A

Model 236-605, Series A

Model 236-712, Series A

Ref No.	Part No.	Description	Qty
101	236-417	MOTOR, hydraulic, Viscount I+ See 308-330 for parts	1
102	183-033	ROD, tie; 13.625" (346 mm) between shoulders	3
103	100-103	PIN, cotter; 1/8" dia x 1-1/2"	1
104	156-082	PACKING, o-ring; buna-N	1
105	220-883	COUPLING	1
107	220-549	DISPLACEMENT PUMP Used on Model 236-605 See separate parts list on page 30	1
	220-547	DISPLACEMENT PUMP Used on Model 236-601 See separate parts list on page 30	1
	220-551	DISPLACEMENT PUMP Used on Model 236-712 See separate parts list on page 30	1
108	108-527	NUT, lock, hex; 9/16-12 unc	3
112	100-001	SCREW, cap, hex hd; 5/16-18 unc-2a x 0.625 in. (16 mm)	4
113	100-214	LOCKWASHER; 0.318"	4
114	189-206	PLATE, adapter	1

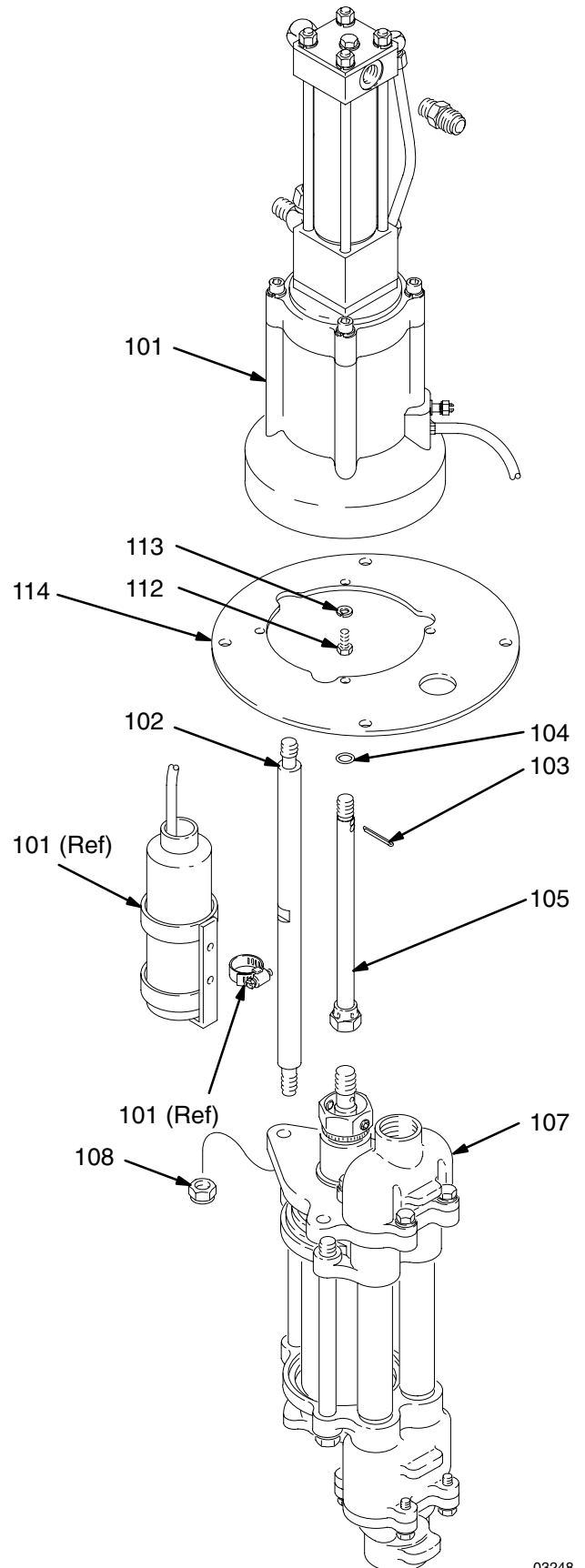

## SEVERE-DUTY, ELECTROPOLISHED STAINLESS STEEL PUMPS

Model 236-602, Series A

Model 236-606, Series A

Model 236-713, Series A

Ref No.	Part No.	Description	Qty
101	236-417	MOTOR, hydraulic, Viscount I+ See 308-330 for parts	1
102	183-089	ROD, tie; 13.625" (346 mm) between shoulders	3
103	101-946	PIN, cotter; 1/8" dia x 1-1/2"	1
104	156-082	PACKING, o-ring; buna-N	1
105	220-883	COUPLING	1
107	220-555	DISPLACEMENT PUMP Used on Model 236-606 See separate parts list on page 32	1
	220-553	DISPLACEMENT PUMP Used on Model 236-602 See separate parts list on page 32	1
	220-557	DISPLACEMENT PUMP Used on Model 236-713 See separate parts list on page 32	1
108	108-683	NUT, lock, hex; 9/16-12 unc	3
112	100-001	SCREW, cap, hex hd; 5/16-18 unc-2a x 0.625 in. (16 mm)	4
113	100-214	LOCKWASHER; 0.318"	4
114	189-206	PLATE, adapter	1

03248

# Parts

## CARBON STEEL DISPLACEMENT PUMPS

### Model 220–549, Series D

For Pump Models 220–560, 220–565, and 236–605

### Model 220–551, Series D

For Pump Models 220–559, 220–567, 220–577, and 236–712

### Model 220–547, Series D

For Pump Models 220–561, 220–566, and 236–601

### Model 237–221, Series A

For Pump Model 237–223

Ref No.	Part No.	Description	Qty	Ref No.	Part No.	Description	Qty
1	181–727	HOUSING, pump, upper	1	22	181–728	HOUSING, outlet	1
2*	108–526	PACKING, o-ring; PTFE	6	23	110–259	BALL; sst; 1" dia.	2
3	183–085	TUBE, fluid	2	24	183–095	SEAT, valve; sst	2
4	See Matrix	CYLINDER, pump	1	25†	See Matrix	V-PACKING, throat	See Matrix
5	101–968	BALL; sst; 1.25" dia.	2	26†	187–117	GLAND, female; sst	1
6	181–686	SEAT, valve, non-vented	1	31	110–208	PLUG, pipe, headless; 1/8 npt; sst	2
7*	181–877	GASKET, seat, valve; UHMWPE	4	32	220–996	SEAT, valve, vented	1
8	111–003	WASHER, flat; 8.4 mm; sst	8	33▲	183–478	PLATE, warning	1
9	107–558	CAPSCREW, hex hd; M8 x 1.25 x 25	8	34	100–508	SCREW, drive, type U; 3/16" long	2
10	181–729	HOUSING, intake	1				
11	181–730	HOUSING, pump, lower	1				
12	108–528	NUT, piston	1				
13	108–524	CAPSCREW, hex hd; 9/16–12 unc x 7.75" long	3				
14	101–333	LOCKWASHER, spring; 9/16"	3				
15*	See Matrix	PACKING, piston	1				
16	See Matrix	PISTON	2				
17	181–898	ROD, piston	1				
18*	See Matrix	GASKET, cylinder; UHMWPE	2				
19†	183–293	GLAND, male; sst	1				
20†	See Matrix	V-PACKING, throat	See Matrix				
21	181–684	NUT, packing	1				

\* These parts are included in the Seal Repair Kit, which may be purchased separately. Refer to the Parts Matrix to determine the correct kit for your pump. See also page 34.

† These parts are included in the Throat Packing Repair Kit, which may be purchased separately. Refer to the Parts Matrix to determine the correct kit for your pump. See also page 34.

▲ Replacement Danger and Warning labels, tags and cards are available at no cost.

## Parts Matrix

Find the part number of your pump in the left column. Read across from left to right to find the applicable part numbers for ref. numbers 4, 15, 16, 18, 20, 25, the Seal Repair Kit, and the Throat Repair Kit.

Pump Model	Ref. No. 4 Cylinder	Ref. No. 15* Piston Packing	Ref No. 16 Piston	Ref. No. 18* Cylinder Gasket	Ref. No. 20† V-Packing	Ref. No. 25† V-Packing	Seal Repair Kit	Throat Repair Kit
220–549	183–032	183–039 uhmwpe	183–040	183–094	183–295 uhmwpe (3)	183–294 Leather (2)	220–588	220–586
220–551	181–900	181–793 uhmwpe	181–792	181–876	183–295 uhmwpe (3)	183–294 Leather (2)	220–587	220–586
220–547	181–899	181–680 uhmwpe	181–685	181–875	183–295 uhmwpe (3)	183–294 Leather (2)	220–589	220–586
237–221	181–899	187–761 PTFE	181–685	181–875	None	183–352 PTFE (5)	224–934	220–585

\* These parts are included in the Seal Repair Kit, which may be purchased separately. Refer to page 34.

† These parts are included in the Throat Packing Repair Kit, which may be purchased separately. Refer to page 34.

# Parts

## CARBON STEEL DISPLACEMENT PUMPS

### Model 220–549, Series D

For Pump Models 220–560, 220–565, and 236–605

### Model 220–551, Series D

For Pump Models 220–559, 220–567, 220–577, and 236–712

### Model 220–547, Series D

For Pump Models 220–561, 220–566, and 236–601

### Model 237–221, Series A

For Pump Model 237–223

**NOTE:** See Service Section for important assembly procedures, torque notes, and sealants.

#### Model 220–549 Shown

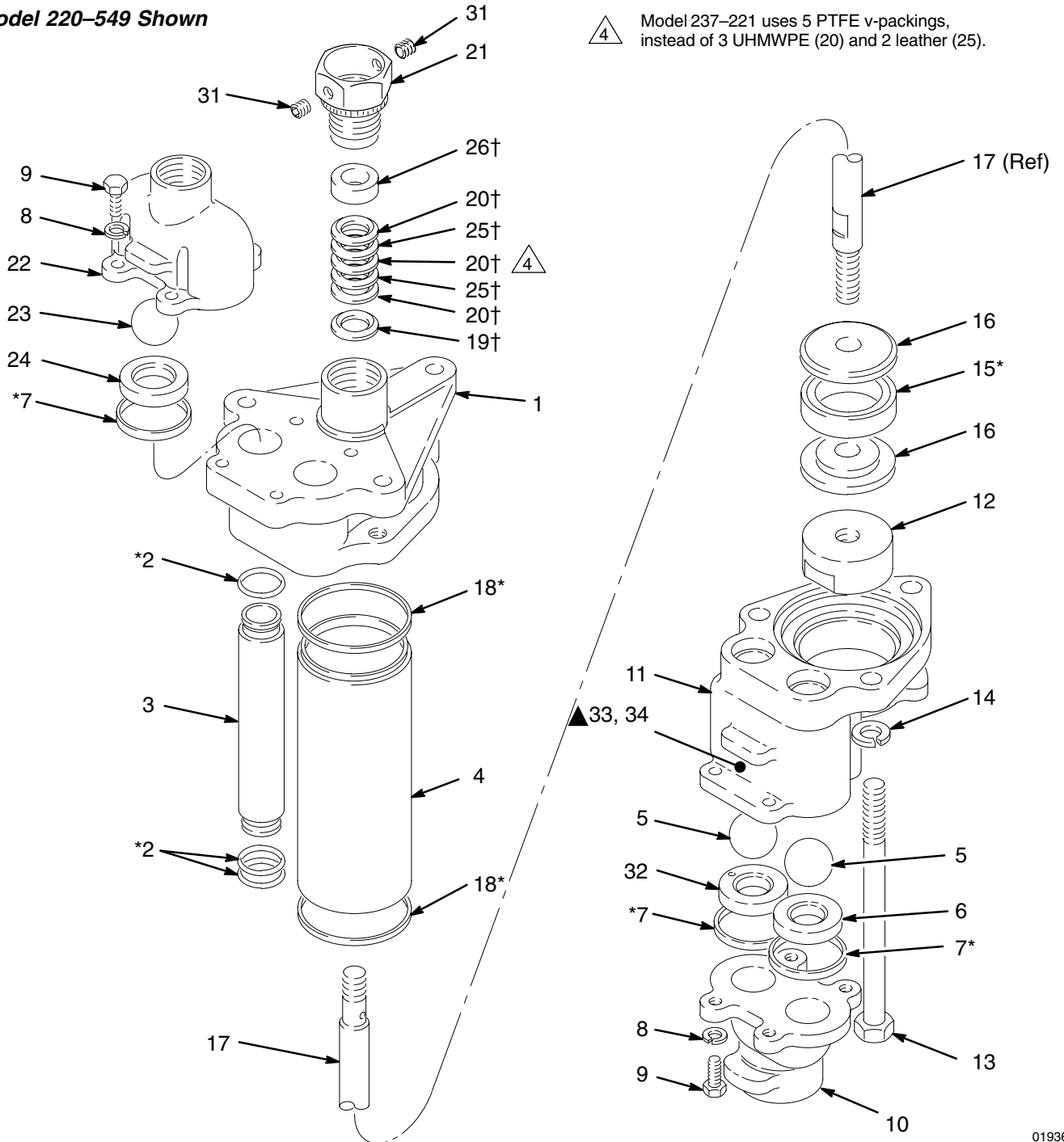

# Parts

## SEVERE-DUTY ELECTROPOLISHED STAINLESS STEEL DISPLACEMENT PUMPS

**Model 220–555, Series E;** for Pump Models 220–563, 220–568, and 236–606

**Model 220–557, Series E;** for Pump Models 220–562, 220–570, 220–578, and 236–713

**Model 239–816, Series A;** for Pump Model 239–815

**Model 220–553, Series E;** for Pump Models 220–564, 220–569, and 236–602

**Model 239–820, Series A;** for Pump Model 239–819

**Model 237–220, Series A;** for Pump Model 237–222

Ref No.	Part No.	Description	Qty	Ref No.	Part No.	Description	Qty
1	181–906	HOUSING, pump, upper	1	22	188–104	HOUSING, outlet	1
2*	108–526	PACKING, o-ring; PTFE	6		239–818	HOUSING, outlet; used on Models 239–816 and 239–820 only	1
3	183–085	TUBE, fluid	2	23	110–259	BALL; sst; 1" dia.	2
4	See Matrix	CYLINDER, pump	1	24	183–095	SEAT, valve; sst	2
5	101–968	BALL; sst; 1.25" dia.	2	25†	See Matrix	V-PACKING, throat	See Matrix
6	181–686	SEAT, valve, non-vented	1	26†	187–117	GLAND, female; sst	1
7*	181–877	GASKET, seat, valve; UHMWPE	4	31	110–208	PLUG, pipe, headless; 1/8 npt; sst	2
8	111–003	WASHER, flat; 8.4 mm; sst	8	32	220–996	SEAT, valve, vented	1
9	112–084	CAPSCREW, hex hd; M8 x 1.25 x 25	8	33▲	183–478	PLATE, warning	1
10	188–103	HOUSING, intake	1	34	103–972	SCREW, drive, type U; 3/16" long	2
	239–817	HOUSING, intake; used on Models 239–816 and 239–820 only	1				
11	181–905	HOUSING, pump, lower	1				
12	108–528	NUT, piston	1				
13	108–523	CAPSCREW, hex hd; 9/16–12 unc x 7.75" long	3				
14	108–525	LOCKWASHER, spring; 9/16"	3				
15*	See Matrix	PACKING, piston	1				
16	See Matrix	PISTON	2				
17	181–898	ROD, piston	1				
18*	See Matrix	GASKET, cylinder; UHMWPE	2				
19†	183–293	GLAND, male; sst	1				
20†	See Matrix	V-PACKING, throat	See Matrix				
21	181–684	NUT, packing	1				

\* These parts are included in the Seal Repair Kit, which may be purchased separately. Refer to the Parts Matrix to determine the correct kit for your pump. See also page 34.

† These parts are included in the Throat Packing Repair Kit, which may be purchased separately. Refer to the Parts Matrix to determine the correct kit for your pump. See also page 34.

▲ Replacement Danger and Warning labels, tags and cards are available at no cost.

## Parts Matrix

Find the part number of your pump in the left column. Read across from left to right to find the applicable part numbers for ref. numbers 4, 15, 16, 18, 20, 25, the Seal Repair Kit, and the Throat Repair Kit.

Pump Model	Ref. No. 4 Cylinder	Ref. No. 15* Piston Packing	Ref No. 16 Piston	Ref. No. 18* Cylinder Gasket	Ref. No. 20† V-Packing	Ref. No. 25† V-Packing	Seal Repair Kit*	Throat Repair Kit†
220–555	183–047	183–039 uhmwpe	183–082	183–094	183–295 uhmwpe (3)	183–294 Leather (2)	220–588	220–586
220–557 & 239–816	183–048	181–793 uhmwpe	183–083	181–876	183–295 uhmwpe (3)	183–294 Leather (2)	220–587	220–586
220–553 & 239–820	183–049	181–680 uhmwpe	183–081	181–875	183–295 uhmwpe (3)	183–294 Leather (2)	220–589	220–586
237–220	183–049	187–761 PTFE	183–081	181–875	None	183–352 PTFE (5)	224–934	220–585

\* These parts are included in the Seal Repair Kit, which may be purchased separately. Refer to page 34.

† These parts are included in the Throat Packing Repair Kit, which may be purchased separately. Refer to page 34.



# Parts

## SEVERE-DUTY ELECTROPOLISHED STAINLESS STEEL DISPLACEMENT PUMPS

Model 220-555, Series E; for Pump Models 220-563, 220-568, and 236-606

Model 220-557, Series E; for Pump Models 220-562, 220-570, 220-578, and 236-713

Model 239-816, Series A; for Pump Model 239-815

Model 220-553, Series E; for Pump Models 220-564, 220-569, and 236-602

Model 239-820, Series A; for Pump Model 239-819

Model 237-220, Series A; for Pump Model 237-222

**NOTE:** See Service Section for important assembly procedures, torque notes, and sealants.

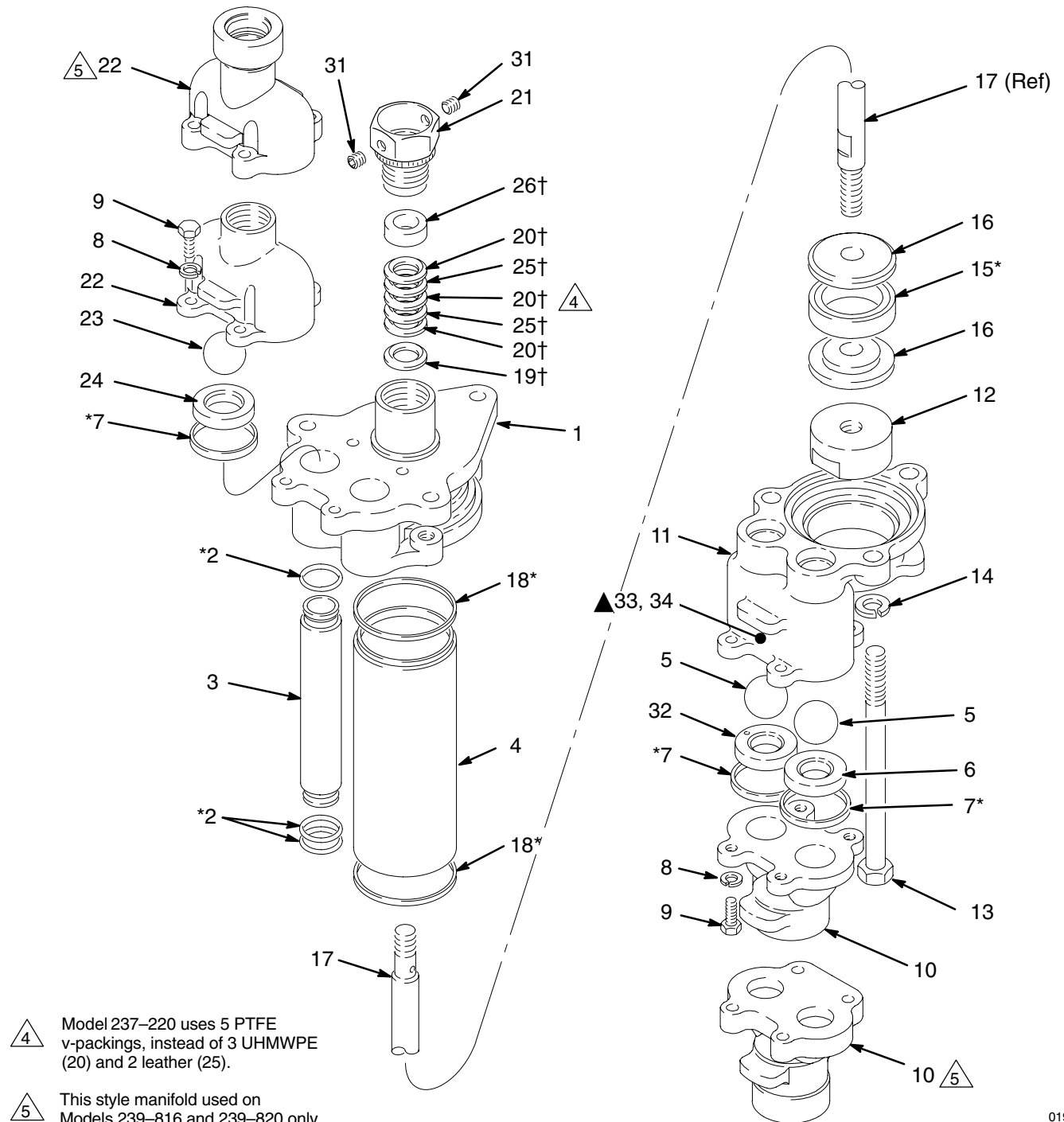

# Repair Kits

**NOTE:** Refer to the parts lists on pages 30–33 and the Service section on pages 20–23 for further information.

## Pump Seal Kit 220–589

For Pump Models 220–566, 220–569, 220–561, 220–564, 239–819, 236–601, and 236–602.

Ref No.	Part No.	Description	Qty
2	108–526	Packing	6
7	181–877	Gasket	4
15	181–680	Packing; UHMWPE	1
18	181–875	Gasket	2

## Pump Seal Kit 220–588

For Pump Models 220–565, 220–568, 220–560, 220–563, 236–605, and 236–606.

Ref No.	Part No.	Description	Qty
2	108–526	Packing	6
7	181–877	Gasket	4
15	183–039	Packing; UHMWPE	1
18	183–094	Gasket	2

## Pump Seal Kit 220–587

For Pump Models 220–577, 220–578, 239–815, 220–567, 220–570, 220–559, 220–562, 236–712 and 236–713.

Ref No.	Part No.	Description	Qty
2	108–526	Packing	6
7	181–877	Gasket	4
15	181–793	Packing; UHMWPE	1
18	181–876	Gasket	2

## Pump PTFE Seal Kit 224–934

To repair Pump Models 237–222 and 237–223, or convert Models 220–566, 220–569, 220–561, 220–564, 239–819, 236–601, and 236–602 to PTFE piston packing.

Ref No.	Part No.	Description	Qty
2	108–526	Packing	6
7	181–877	Gasket	4
15	187–761	Packing; PTFE	1
18	181–875	Gasket	2

## Pump PTFE Seal Conversion Kit 224–935

For Pump Models 220–565, 220–568, 220–560, 220–563, 236–605, and 236–606.

Ref No.	Part No.	Description	Qty
2	108–526	Packing	6
7	181–877	Gasket	4
15	187–762	Packing; PTFE	1
18	183–094	Gasket	2

## Pump PTFE Seal Conversion Kit 224–936

For Pump Models 220–577, 220–578, 239–815, 220–567, 220–570, 220–559, 220–562, 236–712 and 236–713.

Ref No.	Part No.	Description	Qty
2	108–526	Packing	6
7	181–877	Gasket	4
15	187–763	Packing; PTFE	1
18	181–876	Gasket	2

## High Temperature Seal Conversion Kit 236–057

For Pump Models 220–566, 220–569, 220–561, 220–564, 239–819, 236–601, and 236–602.

Ref No.	Part No.	Description	Qty
2	108–526	Packing	6
7	181–877	Gasket	4
15	188–851	Packing; UHMWPE	1
18	181–875	Gasket	2

## Throat Packing Kit 220–586

For all pumps.

Ref No.	Part No.	Description	Qty
19	183–293	Gland	1
20	183–295	Packing	3
25	183–294	Packing	2
26	187–117	Gland	1

## Throat Packing PTFE Kit 220–585

With PTFE packings. For all pumps. Throat packing repair kit for Models 237–222 and 237–223.

Ref No.	Part No.	Description	Qty
19	183–293	Gland	1
25	183–352	Packing	5
26	187–117	Gland	1

# Dimensions

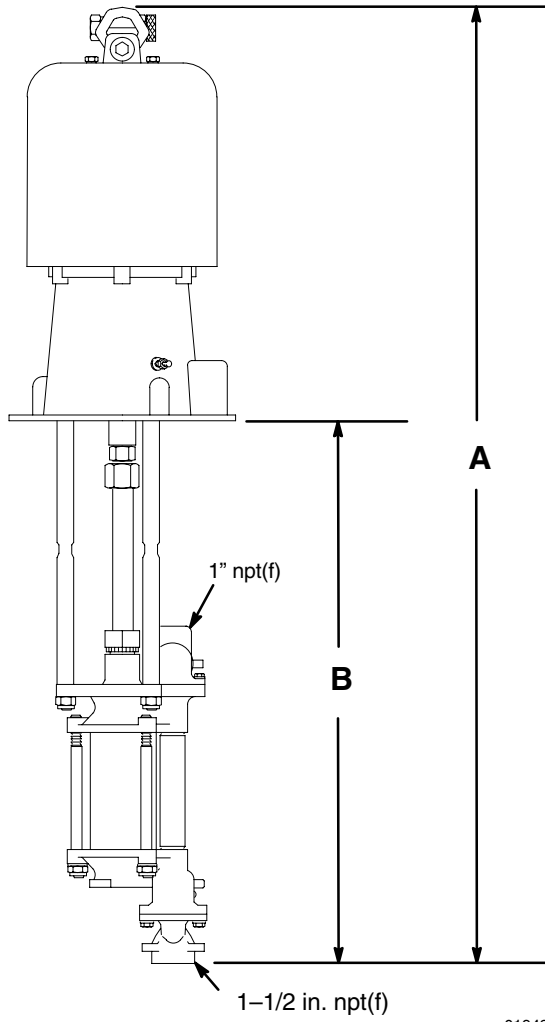

Pump Model	A	B	Weight (approx.)
President CST	1158 mm (45.60 in.)	731 mm (28.78 in.)	30 kg (66 lb)
President SST	1158 mm (45.60 in.)	731 mm (28.78 in.)	27 kg (59 lb)
Model 239-819 President SST	1180 mm (46.48 in.)	753 mm (29.66 in.)	27 kg (59 lb)
Senator CST	1260 mm (49.60 in.)	712 mm (28.04 in.)	36 kg (80 lb)
Senator SST	1260 mm (49.60 in.)	712 mm (28.04 in.)	33 kg (73 lb)
Bulldog CST	1258 mm (49.53 in.)	712 mm (28.04 in.)	42 kg (92 lb)
Bulldog SST	1258 mm (49.53 in.)	712 mm (28.04 in.)	39 kg (85 lb)
Model 239-815 Bulldog SST	1280 mm (50.41 in.)	734 mm (28.92 in.)	39 kg (85 lb)
Viscount I+ CST	1245 mm (49.0 in.)	711 mm (28.0 in.)	35 kg (76 lb)
Viscount I+ SST	1245 mm (49.0 in.)	711 mm (28.0 in.)	32 kg (69 lb)

## Mounting Hole Diagram

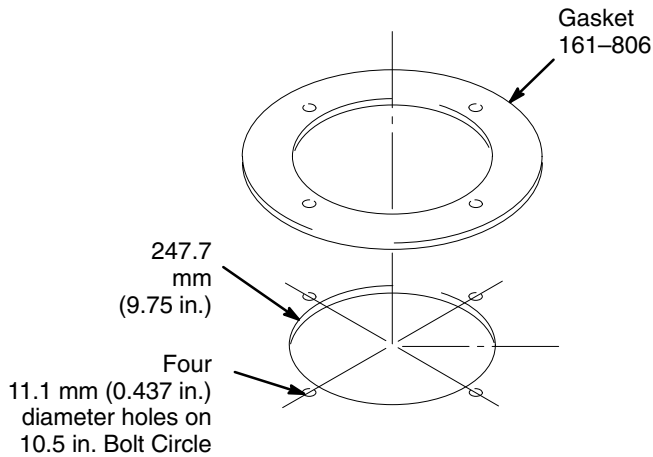

## Surge Stand Bolt Pattern

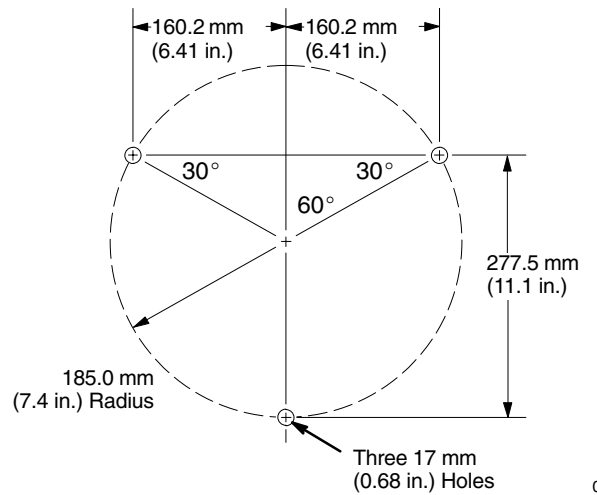

01943

# Accessories

*Use Only Genuine Graco Parts and Accessories*

## Grounding Wire and Clamp 237-569

7.6 m (25 ft) long

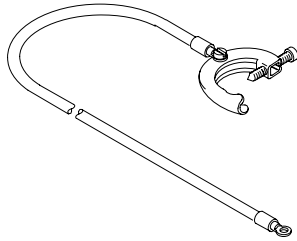

## Pump Runaway Valve 224-040

0.8 MPa, 8.4 bar (120 psi) Maximum Working Pressure

Shuts off air supply to the pump if the pump accelerates beyond the pre-adjusted setting due to an empty supply container, interrupted fluid supply to the pump, or excessive cavitation.

3/4 npt(f) inlet and outlet.

Includes optional 90°

3/4 npsm swivel outlet fitting.

See instruction manual 308-201.

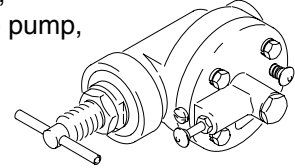

## Bleed-Type Master Air Valve

2.1 MPa, 21 bar (300 psi) Maximum Working Pressure

Relieves air trapped in the air line between the pump air inlet and this valve when closed.

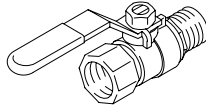

## Air Line Lubricator

1.75 MPa, 17.5 bar (250 psi) Maximum Working Pressure

For automatic air motor lubrication.

214-848 1/2 npt(f) inlet and outlet

214-849 3/4 npt(f) inlet and outlet

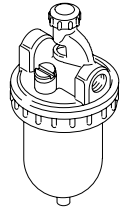

107-141 3/4 npt (mx) inlet and outlet

107-142 1/2 npt (mx) inlet and outlet

## Air Control Kit 207-651

2.1 MPa, 21 bar (300 psi) Maximum Working Pressure

0.1-0.9 MPa, 1-9 bar (10-125 psi) Adjustable Outlet Pressure Range

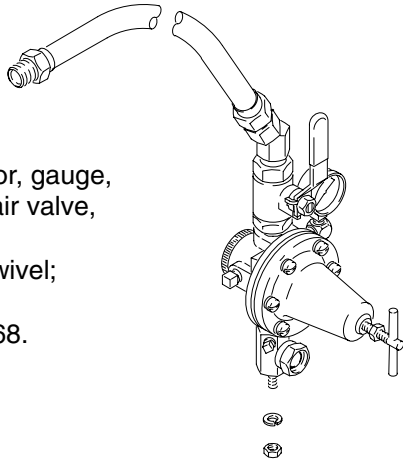

Includes air regulator, gauge, bleed-type master air valve, hose, and manifold.

Inlet: 3/4 npsm(f) swivel;

Outlet: 3/4 npt(m).

See manual 308-168.

## Medium Volume High-Flo Surge Tank 220-157

Reduces fluid pulsation in the fluid line. Stainless steel. 1 in. npt(f) inlet; 1-1/2 npt(f) outlet. Refer to manual 307-707.

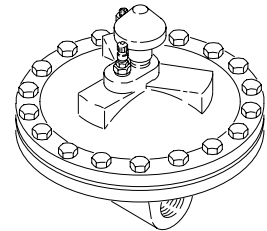

## Riser Tube Kits

Adapts medium volume High-Flo displacement pump outlet to motor level when the pump is drum mounted.

220-580 For President and Viscount Pumps

220-584 For Senator and Bulldog Pumps

Refer to medium volume High-Flo Accessories Manual 307-837.

## Air Line Filter

1.75 MPa, 17.5 bar (250 psi) Maximum Working Pressure

Removes harmful moisture and contaminants from the compressed air supply.

106-149 1/2 npt(f) inlet and outlet

106-150 3/4 npt(f) inlet and outlet

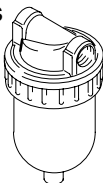

## Fluid Supply Hose

3.5 MPa, 35 bar (500 psi) Maximum Working Pressure

1 in. ID, coupled 1-11 1/2 npt(mbe).

220-997 0.6 m (2 ft) long

214-959 1.8 m (6 ft) long

# Accessories

Use Only Genuine Graco Parts and Accessories

## Mounting Stand Kit 218-742

For mounting the surge tank to the floor.

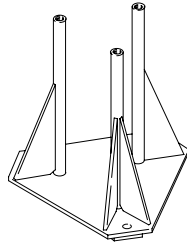

## Pump Floor Stand 220-581

For mounting medium volume High-Flo pumps in a suction feed system. Refer to the Medium Volume High-Flo Accessories Manual, 307-837.

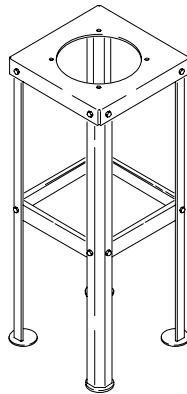

## Stationary Stand 207-872

For President, Bulldog, and Senator Pumps.

## Wall Bracket 206-221

For mounting medium volume High-Flo pump to a wall.

## Portable Cart 218-028

For President, Bulldog, and Senator Pumps.

## Packing Nut Wrench 110-335

For tightening the packing nut.

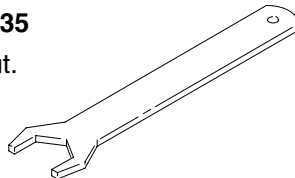

## Throat Seal Liquid (TSL)

Non-evaporating liquid for packing nut/wet-cup.

206-995 0.95 liter (1 quart)

206-996 3.8 liter (1 gal.)

## Graco-Approved Hydraulic Fluid

169-236 20 liter (5 gal.)

207-428 3.8 liter (1 gal.)

## Hydraulic Shutoff Valve 102-644

For hydraulic supply or return line. 3/4 npt(f).

## Hydraulic Supply and Return Hose

10.5 MPa, 105 bar (1500 psi) Maximum Working Pressure

5/8 in. ID, coupled 3/4 npt x 7/8-14, 90° swivel elbow, grounded, for return line.

180-091 0.9 m (3 ft) long

180-092 1.8 m (6 ft) long

13.8 MPa, 138 bar (2000 psi) Maximum Working Pressure

1/2 in. ID, coupled 1/2 npt(m) x 3/4-16, 90° swivel elbow, grounded, for supply line.

180-090 0.9 m (3 ft) long

180-093 1.8 m (6 ft) long

## Pump Mounting Adapter Kits

Provides adapter plate and tie rods for retrofitting existing motor to a High-Flo displacement pump. Refer to Medium Volume High-Flo Accessories Manual 307-837.

220-579 For Series A, B, C, or D Bulldog Motors, Part No. 208-356, and Series A Senator Motor, Part No. 217-540. More recent series of these motors do not require this kit.

221-159 Required for all Viscount I and President Motors.

## Siphon Tube Kit 213-099

To draw fluid from a 200 liter (55 gallon) drum.

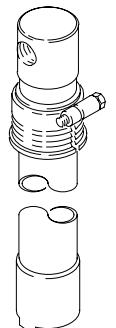

# Technical Data

## 1.5:1 Ratio President Pumps, Models 220–559 and 220–562

Maximum Working Pressure ..... 1.9 MPa, 19 bar (270 psi)  
 Air Operating Range . . . 0.1–1.2 MPa, 1.4–12 bar (20–180 psi)  
 Air Consumption ..... See Performance Chart  
 Continuous Duty Delivery ..... 75 liter/min (20 gpm)  
 Pump Cycles Per Liter (gallon) ..... 0.80 (3.0)  
 Maximum Recommended Pump Speed ..... 60 cycles/min  
 Air Inlet ..... 1/2 npt(f)

Fluid Inlet ..... 1–1/2" npt(f)  
 Fluid Outlet ..... 1" npt  
 Wetted Parts  
*Model 220–559* ..... Carbon Steel, Stainless Steel, Ultra-High Molecular Weight Polyethylene, Leather, PTFE  
*Model 220–562* ..... Chrome-Plated Stainless Steel, Ultra-High Molecular Weight Polyethylene, Leather, PTFE

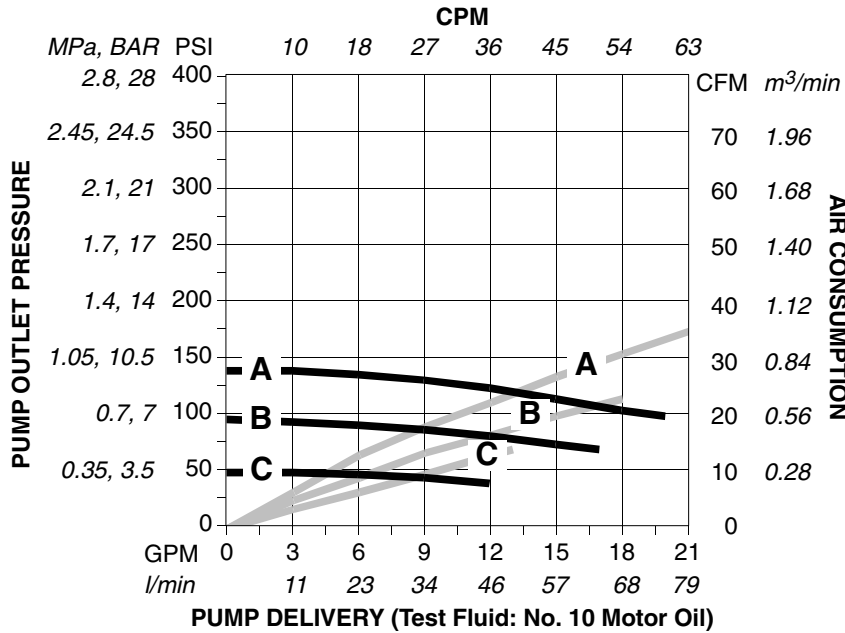

**A** 0.7 MPa, 7 bar (100 psi) air pressure  
**B** 0.49 MPa, 4.9 bar (70 psi) air pressure  
**C** 0.28 MPa, 2.8 bar (40 psi) air pressure

**To find Outlet Pressure** (MPa/bar/psi) at a specific delivery (liter/min or gpm) and operating air pressure (MPa/bar/psi):

1. Locate desired delivery along bottom of chart.
2. Read vertical line up to intersection with selected fluid outlet pressure curve (black curves). Curve slopes from left to right. Follow left to scale and read outlet pressure.

**To find Pump Air Consumption** (m<sup>3</sup>/min or CFM/min) at a specific delivery (liter/min or gpm) and operating air pressure (MPa/bar/psi):

1. Locate desired delivery along bottom of chart.
2. Read vertical line up to intersection with selected air consumption curve (gray curves). Curve slopes from right to left. Follow right to scale and read air consumption.

## 2:1 Ratio President Pumps, Models 220–560 and 220–563

Maximum Working Pressure ..... 2.5 MPa, 25 bar (360 psi)  
 Air Operating Range . . . 0.1–1.2 MPa, 1.4–12 bar (20–180 psi)  
 Air Consumption ..... See Performance Chart  
 Continuous Duty Delivery ..... 55 liter/min (14.6 gpm)  
 Pump Cycles Per Liter (gallon) ..... 1.0 (4.1)  
 Maximum Recommended Pump Speed ..... 60 cycles/min  
 Air Inlet ..... 1/2 npt(f)

Fluid Inlet ..... 1–1/2" npt(f)  
 Fluid Outlet ..... 1" npt  
 Wetted Parts  
*Model 220–560* ..... Carbon Steel, Stainless Steel, Ultra-High Molecular Weight Polyethylene, Leather, PTFE  
*Model 220–563* ..... Chrome-Plated Stainless Steel, Ultra-High Molecular Weight Polyethylene, Leather, PTFE

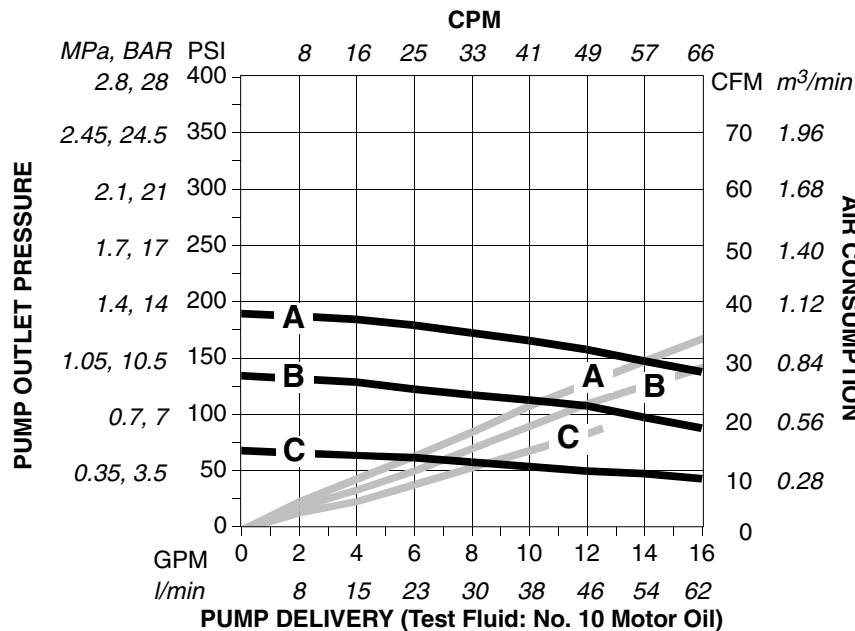

**A** 0.7 MPa, 7 bar (100 psi) air pressure  
**B** 0.49 MPa, 4.9 bar (70 psi) air pressure  
**C** 0.28 MPa, 2.8 bar (40 psi) air pressure

**To find Outlet Pressure** (MPa/bar/psi) at a specific delivery (liter/min or gpm) and operating air pressure (MPa/bar/psi):

1. Locate desired delivery along bottom of chart.
2. Read vertical line up to intersection with selected fluid outlet pressure curve (black curves). Curve slopes from left to right. Follow left to scale and read outlet pressure.

**To find Pump Air Consumption** (m<sup>3</sup>/min or CFM/min) at a specific delivery (liter/min or gpm) and operating air pressure (MPa/bar/psi):

1. Locate desired delivery along bottom of chart.
2. Read vertical line up to intersection with selected air consumption curve (gray curves). Curve slopes from right to left. Follow right to scale and read air consumption.

# Technical Data

## 3:1 Ratio President Pumps, Models 220–561, 220–564, 237–222, 237–223, and 239–819

Maximum Working Pressure . . . . . 3.4 MPa, 34 bar (500 psi)  
 Air Operating Range . . . . . 0.1–1.1 MPa, 1.4–11 bar (20–166 psi)  
 Air Consumption . . . . . See Performance Chart  
 Continuous Duty Delivery . . . . . 35.3 liter/min (9.3 gpm)  
 Pump Cycles Per Liter (gallon) . . . . . 1.7 (6.25)  
 Maximum Recommended Pump Speed . . . . . 60 cycles/min  
 Air Inlet . . . . . 1/2 npt(f)  
 Fluid Inlet . . . . . 1–1/2" npt(f)  
 Fluid Outlet . . . . . 1" npt

### Wetted Parts

*Model 220–561* . . . . . Carbon Steel, Stainless Steel, Ultra-High Molecular Weight Polyethylene, Leather, PTFE  
*Model 220–564* . . . . . Chrome-Plated Stainless Steel, Ultra-High Molecular Weight Polyethylene, Leather, PTFE  
*Model 237–223* . . . . . Carbon Steel, Stainless Steel, Ultra-High Molecular Weight Polyethylene, PTFE  
*Model 237–222* . . . . . Chrome-Plated Stainless Steel, Ultra-High Molecular Weight Polyethylene, PTFE

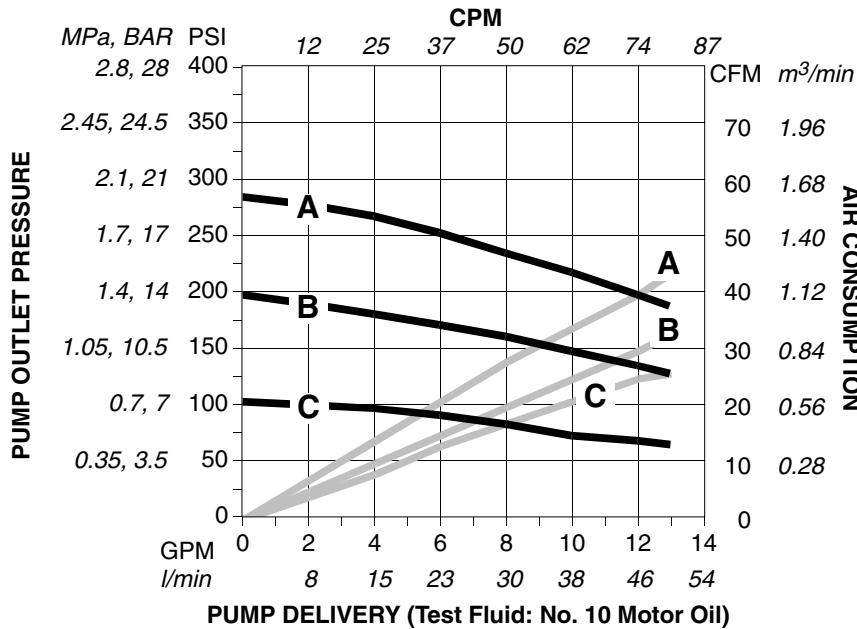

- A** 0.7 MPa, 7 bar (100 psi) air pressure
- B** 0.49 MPa, 4.9 bar (70 psi) air pressure
- C** 0.28 MPa, 2.8 bar (40 psi) air pressure

**To find Outlet Pressure (MPa/bar/psi) at a specific delivery (liter/min or gpm) and operating air pressure (MPa/bar/psi):**

1. Locate desired delivery along bottom of chart.
2. Read vertical line up to intersection with selected fluid outlet pressure curve (black curves). Curve slopes from left to right. Follow left to scale and read outlet pressure.

**To find Pump Air Consumption (m³/min or CFM/min) at a specific delivery (liter/min or gpm) and operating air pressure (MPa/bar/psi):**

1. Locate desired delivery along bottom of chart.
2. Read vertical line up to intersection with selected air consumption curve (gray curves). Curve slopes from right to left. Follow right to scale and read air consumption.

# Technical Data

## 3.5:1 Ratio Quiet Senator Pumps, Models 220–565 and 220–568

Maximum Working Pressure . . . 2.45 MPa, 24.5 bar (350 psi)  
 Air Operating Range . . . 0.28–0.7 MPa, 2.8–7 bar (40–100 psi)  
 Air Consumption . . . . . See Performance Chart  
 Continuous Duty Delivery . . . . . 65.8 liter/min (17.4 gpm)  
 Pump Cycles Per Liter (gallon) . . . . . 0.91 (3.44)  
 Maximum Recommended Pump Speed . . . . . 60 cycles/min  
 Air Inlet . . . . . 3/4 npsm(f)

Fluid Inlet . . . . . 1–1/2" npt(f)  
 Fluid Outlet . . . . . 1" npt  
 Wetted Parts  
*Model 220–565* . . . . . Carbon Steel, Stainless Steel,  
 Ultra-High Molecular Weight Polyethylene, Leather, PTFE  
*Model 220–568* . . . . . Chrome-Plated Stainless Steel,  
 Ultra-High Molecular Weight Polyethylene, Leather, PTFE

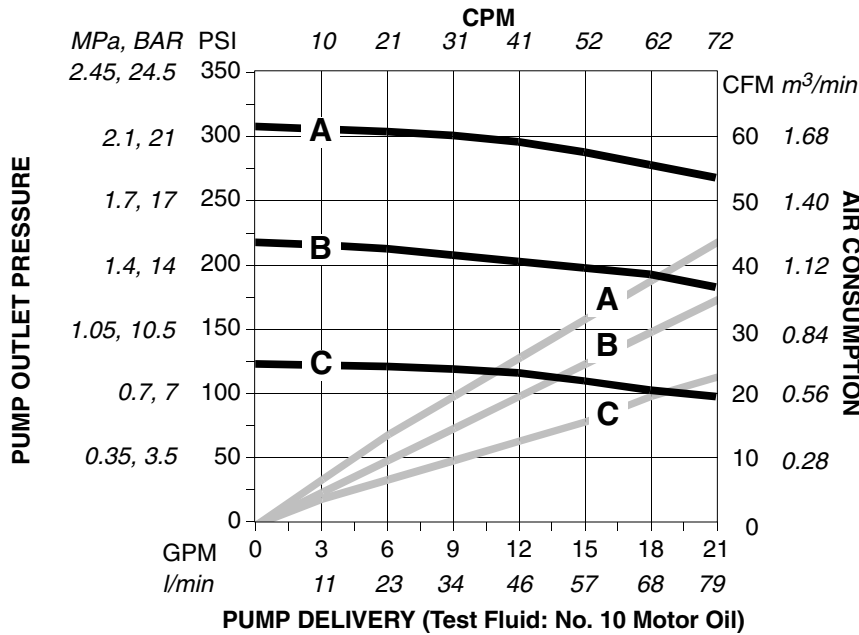

**A** 0.7 MPa, 7 bar (100 psi) air pressure  
**B** 0.49 MPa, 4.9 bar (70 psi) air pressure  
**C** 0.28 MPa, 2.8 bar (40 psi) air pressure

**To find Outlet Pressure** (MPa/bar/psi) at a specific delivery (liter/min or gpm) and operating air pressure (MPa/bar/psi):

1. Locate desired delivery along bottom of chart.
2. Read vertical line up to intersection with selected fluid outlet pressure curve (black curves). Curve slopes from left to right. Follow left to scale and read outlet pressure.

**To find Pump Air Consumption** (m<sup>3</sup>/min or CFM/min) at a specific delivery (liter/min or gpm) and operating air pressure (MPa/bar/psi):

1. Locate desired delivery along bottom of chart.
2. Read vertical line up to intersection with selected air consumption curve (gray curves). Curve slopes from right to left. Follow right to scale and read air consumption.

## 2.5:1 Ratio Quiet Senator Pumps, Models 220–567 and 220–570

Maximum Working Pressure . . . . . 1.7 MPa, 17 bar (250 psi)  
 Air Operating Range . . . . . 0.28–0.7 MPa, 2.8–7 bar (40–100 psi)  
 Air Consumption . . . . . See Performance Chart  
 Continuous Duty Delivery . . . . . 89.9 liter/min (24 gpm)  
 Pump Cycles Per Liter (gallon) . . . . . 0.66 (2.5)  
 Maximum Recommended Pump Speed . . . . . 60 cycles/min  
 Air Inlet . . . . . 3/4 npsm(f)

Fluid Inlet . . . . . 1–1/2" npt(f)  
 Fluid Outlet . . . . . 1" npt  
 Wetted Parts  
*Model 220–567* . . . . . Carbon Steel, Stainless Steel,  
 Ultra-High Molecular Weight Polyethylene, Leather, PTFE  
*Model 220–570* . . . . . Chrome-Plated Stainless Steel,  
 Ultra-High Molecular Weight Polyethylene, Leather, PTFE

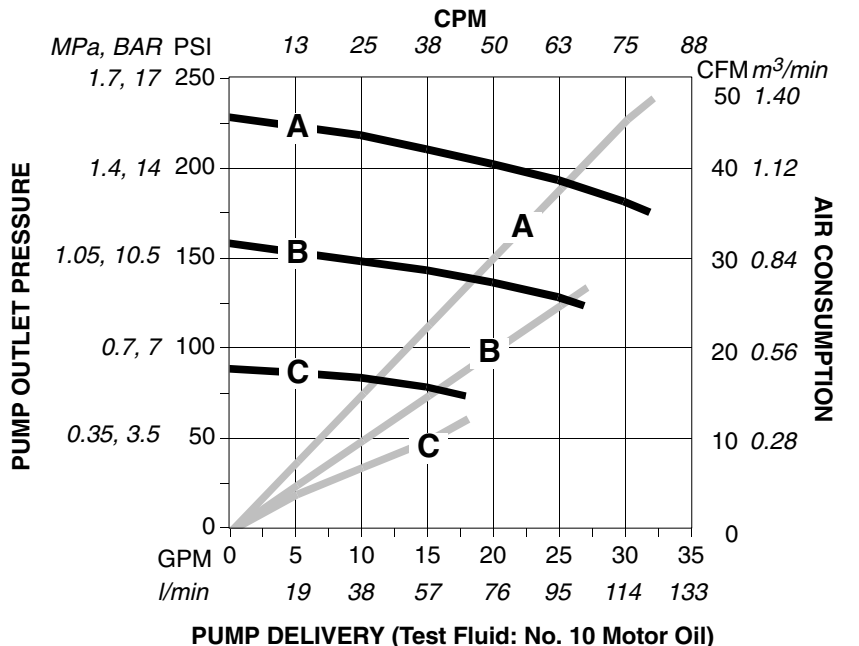

**A** 0.7 MPa, 7 bar (100 psi) air pressure  
**B** 0.49 MPa, 4.9 bar (70 psi) air pressure  
**C** 0.28 MPa, 2.8 bar (40 psi) air pressure

**To find Outlet Pressure** (MPa/bar/psi) at a specific delivery (liter/min or gpm) and operating air pressure (MPa/bar/psi):

1. Locate desired delivery along bottom of chart.
2. Read vertical line up to intersection with selected fluid outlet pressure curve (black curves). Curve slopes from left to right. Follow left to scale and read outlet pressure.

**To find Pump Air Consumption** (m<sup>3</sup>/min or CFM/min) at a specific delivery (liter/min or gpm) and operating air pressure (MPa/bar/psi):

1. Locate desired delivery along bottom of chart.
2. Read vertical line up to intersection with selected air consumption curve (gray curves). Curve slopes from right to left. Follow right to scale and read air consumption.



# Technical Data

## 5:1 Ratio Quiet Senator Pumps, Models 220–566 and 220–569

Maximum Working Pressure . . . . . 3.4 MPa, 34 bar (500 psi)  
 Air Operating Range . . . . . 0.28–0.7 MPa, 2.8–7 bar (40–100 psi)  
 Air Consumption . . . . . See Performance Chart  
 Continuous Duty Delivery . . . . . 45.4 liter/min (12 gpm)  
 Pump Cycles Per Liter (gallon) . . . . . 1.3 (5.0)  
 Maximum Recommended Pump Speed . . . . . 60 cycles/min  
 Air Inlet . . . . . 3/4 npsm(f)

Fluid Inlet . . . . . 1–1/2" npt(f)  
 Fluid Outlet . . . . . 1" npt  
 Wetted Parts  
*Model 220–566* . . . . . Carbon Steel, Stainless Steel,  
 Ultra-High Molecular Weight Polyethylene, Leather, PTFE  
*Model 220–569* . . . . . Chrome-Plated Stainless Steel,  
 Ultra-High Molecular Weight Polyethylene, Leather, PTFE

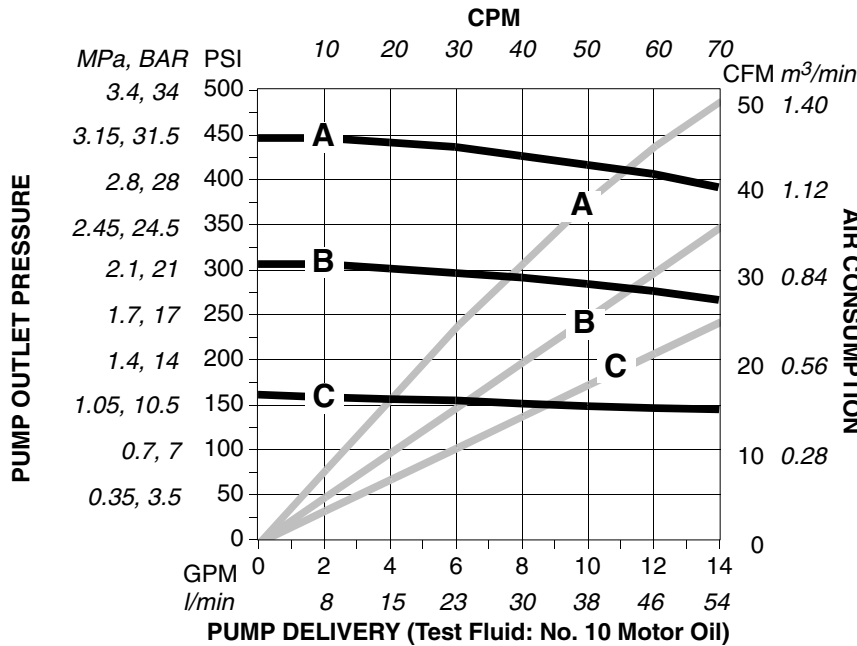

- A** 0.7 MPa, 7 bar (100 psi) air pressure
- B** 0.49 MPa, 4.9 bar (70 psi) air pressure
- C** 0.28 MPa, 2.8 bar (40 psi) air pressure

**To find Outlet Pressure (MPa/bar/psi) at a specific delivery (liter/min or gpm) and operating air pressure (MPa/bar/psi):**

1. Locate desired delivery along bottom of chart.
2. Read vertical line up to intersection with selected fluid outlet pressure curve (black curves). Curve slopes from left to right. Follow left to scale and read outlet pressure.

**To find Pump Air Consumption (m³/min or CFM/min) at a specific delivery (liter/min or gpm) and operating air pressure (MPa/bar/psi):**

1. Locate desired delivery along bottom of chart.
2. Read vertical line up to intersection with selected air consumption curve (gray curves). Curve slopes from right to left. Follow right to scale and read air consumption.



# Technical Data

## 4:1 Ratio Quiet Bulldog Pumps, Models 220–577, 220–578, and 239–815

Maximum Working Pressure . . . . . 2.8 MPa, 28 bar (400 psi)  
 Air Operating Range . . . . . 0.28–0.7 MPa, 2.8–7 bar (40–100 psi)  
 Air Consumption . . . . . See Performance Chart  
 Continuous Duty Delivery . . . . . 90.8 liter/min (24 gpm)  
 Pump Cycles Per Liter (gallon) . . . . . 0.66 (2.5)  
 Maximum Recommended Pump Speed . . . . . 60 cycles/min  
 Air Inlet . . . . . 3/4 npsm(f)

Fluid Inlet . . . . . 1–1/2" npt(f)  
 Fluid Outlet . . . . . 1" npt  
 Wetted Parts  
*Model 220–577* . . . . . Carbon Steel, Stainless Steel,  
 Ultra-High Molecular Weight Polyethylene, Leather, PTFE  
*Model 220–578* . . . . . Chrome-Plated Stainless Steel,  
 Ultra-High Molecular Weight Polyethylene, Leather, PTFE

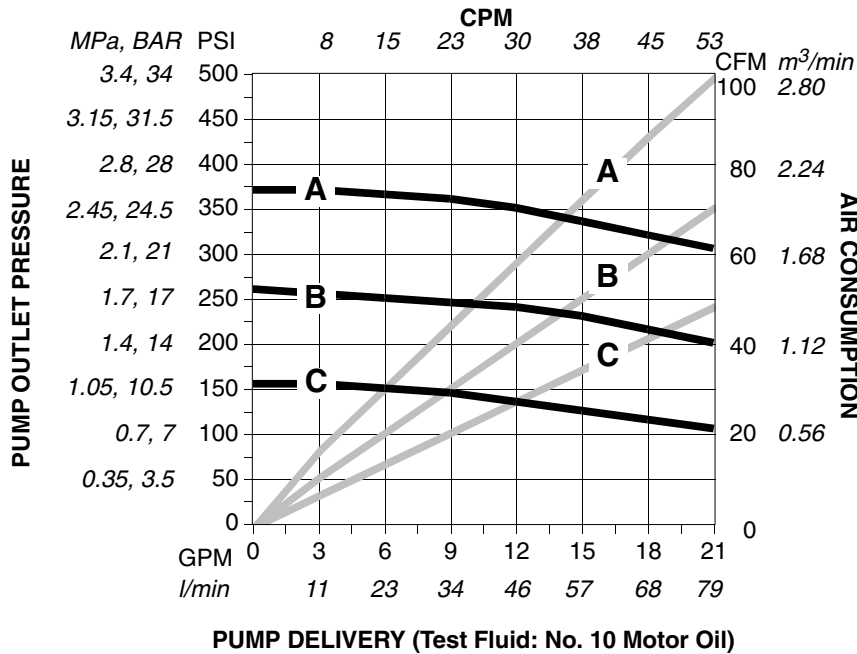

- A** 0.7 MPa, 7 bar (100 psi) air pressure  
**B** 0.49 MPa, 4.9 bar (70 psi) air pressure  
**C** 0.28 MPa, 2.8 bar (40 psi) air pressure
- To find Outlet Pressure (MPa/bar/psi) at a specific delivery (liter/min or gpm) and operating air pressure (MPa/bar/psi):**
1. Locate desired delivery along bottom of chart.
  2. Read vertical line up to intersection with selected fluid outlet pressure curve (black curves). Curve slopes from left to right. Follow left to scale and read outlet pressure.
- To find Pump Air Consumption (m³/min or CFM/min) at a specific delivery (liter/min or gpm) and operating air pressure (MPa/bar/psi):**
1. Locate desired delivery along bottom of chart.
  2. Read vertical line up to intersection with selected air consumption curve (gray curves). Curve slopes from right to left. Follow right to scale and read air consumption.

# Technical Data

## Viscount I+ Pumps, Models 236–601 and 236–602

Maximum Working Pressure . . . . . 3.1 MPa, 31 bar (450 psi)  
 Maximum Hydraulic Working Pressure . . . 10.3 MPa, 103 bar (1500 psi)  
 Continuous Duty Delivery . . . . . 36.5 liter/min (9.6 gpm)  
 Pump Cycles Per Liter (gallon) . . . . . 1.64 (6.2)  
 Maximum Recommended Pump Speed . . . . . 60 cycles/min  
 Maximum Hydraulic Motor Fluid Temperature . . 54°C (134°F)

Hydraulic Fluid Inlet . . . . . 3/4", (37° flare)  
 Hydraulic Fluid Outlet . . . . . 7/8", (37° flare)  
 Wetted Parts  
*Model 236–601* . . . . . Carbon Steel, Stainless Steel, Ultra-High Molecular Weight Polyethylene, Leather, PTFE  
*Model 236–602* . . . . . Chrome-Plated Stainless Steel, Ultra-High Molecular Weight Polyethylene, Leather, PTFE

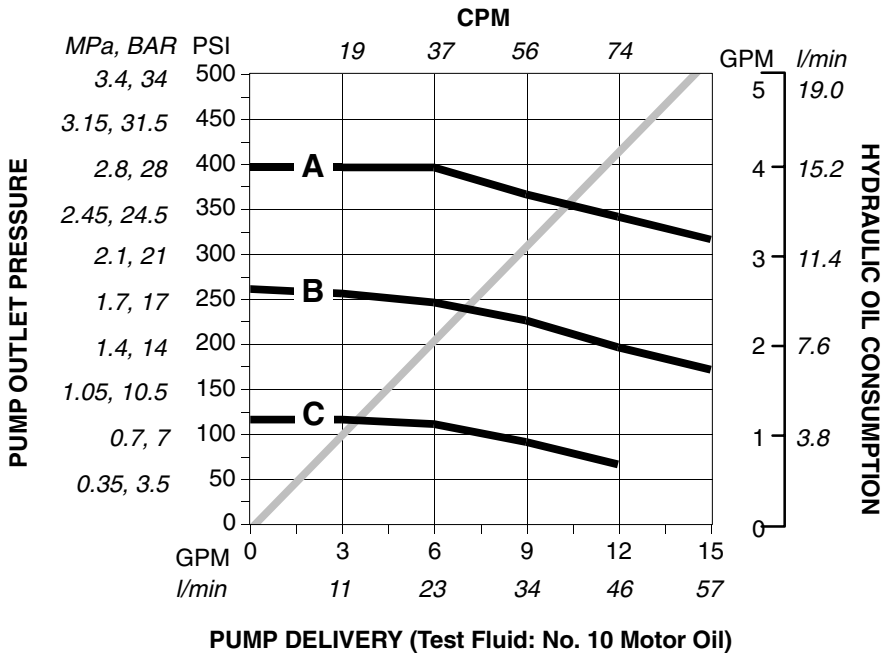

- A** 10.3 MPa, 103 bar (1500 psi) hydraulic oil pressure
- B** 6.9 MPa, 69 bar (1000 psi) hydraulic oil pressure
- C** 3.4 MPa, 34 bar (500 psi) hydraulic oil pressure

**To find Outlet Pressure (MPa/bar/psi) at a specific delivery (liter/min or gpm) and operating hydraulic pressure (MPa/bar/psi):**

1. Locate desired delivery along bottom of chart.
2. Read vertical line up to intersection with selected fluid outlet pressure curve (black curves). Curve slopes from left to right. Follow left to scale and read outlet pressure.

**To find Motor Hydraulic Oil Consumption (liter/min or gpm) at a specific delivery (liter/min or gpm) :**

1. Locate desired delivery along bottom of chart.
2. Read vertical line up to intersection with hydraulic oil consumption curve (gray curve). Curve slopes from right to left. Follow right to scale and read hydraulic oil consumption.

## Viscount I+ Pumps, Models 236–605 and 236–606

Maximum Working Pressure . . . . . 2.1 MPa, 21 bar (300 psi)  
 Maximum Hydraulic Working Pressure . . . 10.3 MPa, 103 bar (1500 psi)  
 Continuous Duty Delivery . . . . . 55.6 liter/min (14.7 gpm)  
 Pump Cycles Per Liter (gallon) . . . . . 1.1 (4.1)  
 Maximum Recommended Pump Speed . . . . . 60 cycles/min  
 Maximum Hydraulic Motor Fluid Temperature . . 54°C (134°F)

Hydraulic Fluid Inlet . . . . . 3/4", (37° flare)  
 Hydraulic Fluid Outlet . . . . . 7/8", (37° flare)  
 Wetted Parts  
*Model 236–605* . . . . . Carbon Steel, Stainless Steel, Ultra-High Molecular Weight Polyethylene, Leather, PTFE  
*Model 236–606* . . . . . Chrome-Plated Stainless Steel, Ultra-High Molecular Weight Polyethylene, Leather, PTFE

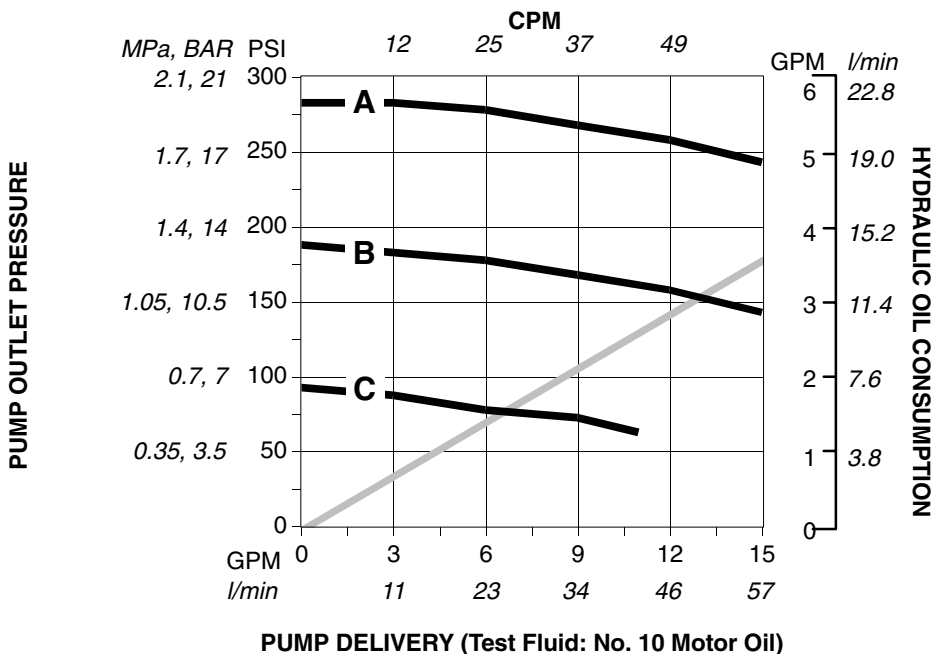

- A** 10.3 MPa, 103 bar (1500 psi) hydraulic oil pressure
- B** 6.9 MPa, 69 bar (1000 psi) hydraulic oil pressure
- C** 3.4 MPa, 34 bar (500 psi) hydraulic oil pressure

**To find Outlet Pressure (MPa/bar/psi) at a specific delivery (liter/min or gpm) and operating hydraulic pressure (MPa/bar/psi):**

1. Locate desired delivery along bottom of chart.
2. Read vertical line up to intersection with selected fluid outlet pressure curve (black curves). Curve slopes from left to right. Follow left to scale and read outlet pressure.

**To find Motor Hydraulic Oil Consumption (liter/min or gpm) at a specific delivery (liter/min or gpm) :**

1. Locate desired delivery along bottom of chart.
2. Read vertical line up to intersection with hydraulic oil consumption curve (gray curve). Curve slopes from right to left. Follow right to scale and read hydraulic oil consumption.

# Technical Data

## Viscount I+ Pumps, Models 236–712 and 236–713

Maximum Working Pressure . . . 1.55 MPa, 15.5 bar (225 psi)  
Maximum Hydraulic Working Pressure . . . 10.3 MPa, 103 bar  
(1500 psi)  
Continuous Duty Delivery . . . . . 75.6 liter/min (20 gpm)  
Pump Cycles Per Liter (gallon) . . . . . 0.8 (3.0)  
Maximum Recommended Pump Speed . . . . . 60 cycles/min  
Maximum Hydraulic Motor Fluid Temperature . . 54°C (134°F)  
Hydraulic Fluid Inlet . . . . . 3/4", (37° flare)

Hydraulic Fluid Outlet . . . . . 7/8", (37° flare)  
Wetted Parts

*Model 236–712* . . . . . Carbon Steel, Stainless Steel,  
Ultra-High Molecular Weight Polyethylene, Leather, PTFE  
*Model 236–713* . . . . . Chrome-Plated Stainless Steel,  
Ultra-High Molecular Weight Polyethylene, Leather, PTFE

Loctite® is a registered trademark of the Loctite Corp.

# The Graco Warranty and Disclaimers

Graco warrants all equipment listed in this manual which is manufactured by Graco and bearing its name to be free from defects in material and workmanship on the date of sale by an authorized Graco distributor to the original purchaser for use. With the exception of any special extended or limited warranty published by Graco, Graco will, for a period of twelve months from the date of sale, repair or replace any part of the equipment determined by Graco to be defective. This warranty applies only when the equipment is installed, operated and maintained in accordance with Graco's written recommendations.

This warranty does not cover, and Graco shall not be liable for general wear and tear, or any malfunction, damage or wear caused by faulty installation, misapplication, abrasion, corrosion, inadequate or improper maintenance, negligence, accident, tampering, or substitution of non-Graco component parts. Nor shall Graco be liable for malfunction, damage or wear caused by the incompatibility of Graco equipment with structures, accessories, equipment or materials not supplied by Graco, or the improper design, manufacture, installation, operation or maintenance of structures, accessories, equipment or materials not supplied by Graco.

This warranty is conditioned upon the prepaid return of the equipment claimed to be defective to an authorized Graco distributor for verification of the claimed defect. If the claimed defect is verified, Graco will repair or replace free of charge any defective parts. The equipment will be returned to the original purchaser transportation prepaid. If inspection of the equipment does not disclose any defect in material or workmanship, repairs will be made at a reasonable charge, which charges may include the costs of parts, labor, and transportation.

Graco's sole obligation and buyer's sole remedy for any breach of warranty shall be as set forth above. The buyer agrees that no other remedy (including, but not limited to, incidental or consequential damages for lost profits, lost sales, injury to person or property, or any other incidental or consequential loss) shall be available. Any action for breach of warranty must be brought within two (2) years of the date of sale.

**GRACO MAKES NO WARRANTY, AND DISCLAIMS ALL IMPLIED WARRANTIES OF MERCHANTABILITY AND FITNESS FOR A PARTICULAR PURPOSE IN CONNECTION WITH ACCESSORIES, EQUIPMENT, MATERIALS OR COMPONENTS SOLD BUT NOT MANUFACTURED BY GRACO.** These items sold, but not manufactured by Graco (such as electric motors, gas engines, switches, hose, etc.), are subject to the warranty, if any, of their manufacturer. Graco will provide purchaser with reasonable assistance in making any claim for breach of these warranties.

In no event will Graco be liable for indirect, incidental, special or consequential damages resulting from Graco supplying equipment hereunder, or the furnishing, performance, or use of any products or other goods sold hereto, whether due to a breach of contract, breach of warranty, the negligence of Graco, or otherwise.

## **FOR GRACO CANADA CUSTOMERS**

The parties acknowledge that they have required that the present document, as well as all documents, notices and legal proceedings entered into, given or instituted pursuant hereto or relating directly or indirectly hereto, be drawn up in English. Les parties reconnaissent avoir convenu que la rédaction du présente document sera en Anglais, ainsi que tous documents, avis et procédures judiciaires exécutés, donnés ou intentés à la suite de ou en rapport, directement ou indirectement, avec les procédures concernées.

## Graco Phone Number

**TO PLACE AN ORDER**, contact your Graco distributor, or call this number to identify the distributor closest to you:  
**1-800-367-4023 Toll Free**

*All written and visual data contained in this document reflects the latest product information available at the time of publication.  
Graco reserves the right to make changes at any time without notice.*

**Sales Offices:** Minneapolis, Detroit, Los Angeles  
**Foreign Offices:** Belgium, Canada, England, Korea, France, Germany, Hong Kong, Japan

**GRACO INC. P.O. BOX 1441 MINNEAPOLIS, MN 55440-1441**

PRINTED IN U.S.A. 307-809 July 1987, Revised March 1998