

Instructions-Parts List



HYDRA-SPRAY®

Monark® and President® Pumps

307619ZAD

EN

**For airless and air-assisted spraying of finishing materials.
For professional use only.**



Important Safety Instructions

Read all warnings and instructions in this manual. Save these instructions.

See page 2 for Table of Contents

Part No. 223596, Series B 23:1 Ratio Monark® Pump

with Part No. 223595 carbon steel severe-duty displacement pump* with stainless steel glands, intake housing, piston valve, and ball stop

2760 psi (19 MPa, 190 bar) Maximum Fluid Working Pressure

120 psi (0.8 MPa, 8 bar) Maximum Air Input Pressure



II 1/2 G Ex h IIB T3 Ga/Gb

ETL23ATEX0276

ITS21UKEX0322

Part No. 237958, Series B 23:1 Ratio Monark® Pump

with Part No. 239145 stainless steel severe-duty displacement pump*

3450 psi (24 MPa, 238 bar) Maximum Fluid Working Pressure

150 psi (1.0 MPa, 10.4 bar) Maximum Air Input Pressure



II 1/2 G Ex h IIB T3 Ga/Gb

ETL23ATEX0276

ITS21UKEX0322

Part No. 239140, Series A 46:1 Ratio President® Pump

with Part No. 239145 stainless steel severe-duty displacement pump*

4600 psi (32 MPa, 317 bar) Maximum Fluid Working Pressure

100 psi (0.7 MPa, 7 bar) Maximum Air Input Pressure



II 2 G Ex h IIB T3 Gb

* Severe-duty displacement pumps have abrasion-resistant displacement rods and sleeves. Refer to **Technical Data** on page 20 for information on the wetted parts.

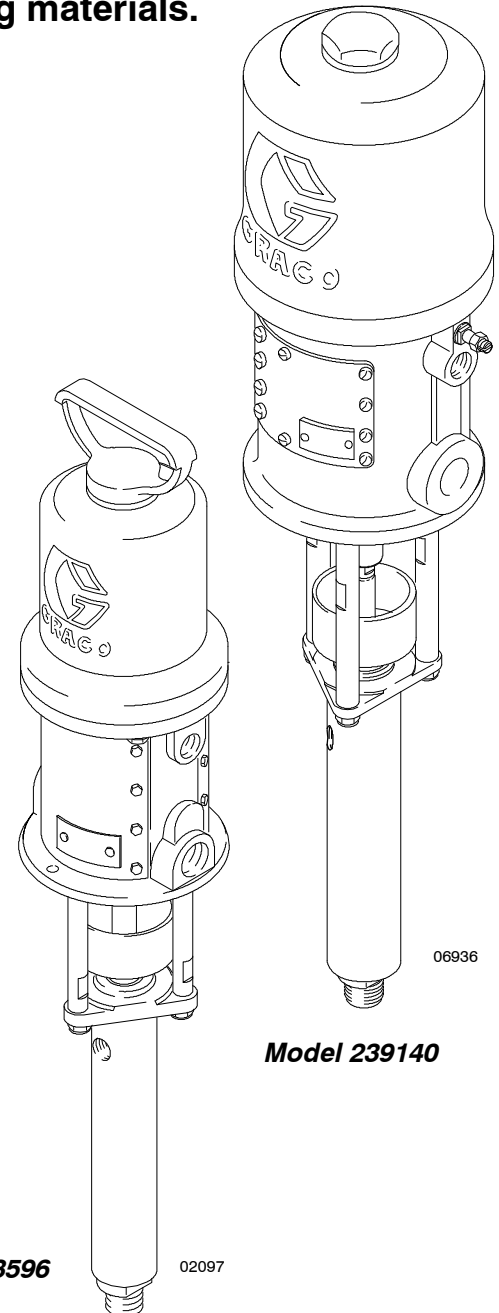

Model 223596

Model 239140



2575



0359

PROVEN QUALITY. LEADING TECHNOLOGY.

Table of Contents

Warnings	2	Parts	14
Installation	5	Conversion Kits	18
Operation	8	Dimensions	19
Troubleshooting	10	Mounting Hole Layout	19
Service		Technical Data	20
Disconnecting the Displacement Pump	11	Graco Standard Warranty	24
Reconnecting the Displacement Pump	11	Graco Information	24
Displacement Pump Service	12		

WARNING



INSTRUCTIONS

EQUIPMENT MISUSE HAZARD

Equipment misuse can cause the equipment to rupture or malfunction and result in serious injury.

- This equipment is for professional use only.
- Read all instruction manuals, tags, and labels before operating the equipment.
- Use the equipment only for its intended purpose. If you are uncertain about usage, call your Graco distributor.
- Do not alter or modify this equipment. Use only genuine Graco parts and accessories.
- Check equipment daily. Repair or replace worn or damaged parts immediately.
- Do not exceed the maximum working pressure of the lowest rated system component. Refer to the **Technical Data** on page 20 for the maximum working pressure of this equipment.
- Use fluids and solvents which are compatible with the equipment wetted parts. Refer to the **Technical Data** section of all equipment manuals. Read the fluid and solvent manufacturer's warnings.
- Do not use hoses to pull equipment.
- Route hoses away from traffic areas, sharp edges, moving parts, and hot surfaces. Do not expose Graco hoses to temperatures above 180°F (82°C) or below -40°F (-40°C).
- Wear hearing protection when operating this equipment.
- Do not lift pressurized equipment.
- Comply with all applicable local, state, and national fire, electrical, and safety regulations.

WARNING



SKIN INJECTION HAZARD

Spray from the gun, hose leaks, or ruptured components can inject fluid into your body and cause extremely serious injury, including the need for amputation. Fluid splashed in the eyes or on the skin can also cause serious injury.



- Fluid injected into the skin might look like just a cut, but it is a serious injury. **Get immediate surgical treatment.**
- Do not point the gun at anyone or at any part of the body.
- Do not put your hand or fingers over the spray tip.
- Do not stop or deflect leaks with your hand, body, glove or rag.
- Do not “blow back” fluid; this is not an air spray system.
- Always have the tip guard and the trigger guard on the gun when spraying.
- Check the gun diffuser operation weekly. Refer to the gun manual.
- Be sure the gun trigger safety operates before spraying.
- Lock the gun trigger safety when you stop spraying.
- Follow the **Pressure Relief Procedure** on page 8 whenever you: are instructed to relieve pressure; stop spraying; clean, check, or service the equipment; and install or clean the spray tip.
- Tighten all fluid connections before operating the equipment.
- Check the hoses, tubes, and couplings daily. Replace worn, damaged, or loose parts immediately. Permanently coupled hoses cannot be repaired; replace the entire hose.
- Use only Graco approved hoses. Do not remove any spring guard that is used to help protect the hose from rupture caused by kinks or bends near the couplings.



MOVING PARTS HAZARD

Moving parts, such as the air motor piston, can pinch or amputate your fingers.

- Keep clear of all moving parts when starting or operating the pump.
- Before servicing the equipment, follow the **Pressure Relief Procedure** on page 8 to prevent the equipment from starting unexpectedly.

WARNING



FIRE AND EXPLOSION HAZARD

Improper grounding, poor ventilation, open flames or sparks can cause a hazardous condition and result in a fire or explosion and serious injury.



- Ground the equipment and the object being sprayed. Refer to **Grounding** on page 5.
- If there is any static sparking or you feel an electric shock while using this equipment, **stop spraying immediately**. Do not use the equipment until you identify and correct the problem.
- Provide fresh air ventilation to avoid the buildup of flammable fumes from solvents or the fluid being sprayed.
- Keep the spray area free of debris, including solvent, rags, and gasoline.
- Electrically disconnect all equipment in the spray area.
- Extinguish all open flames or pilot lights in the spray area.
- Do not smoke in the spray area.
- Do not turn on or off any light switch in the spray area while operating or if fumes are present.
- Do not operate a gasoline engine in the spray area.



TOXIC FLUID HAZARD

Hazardous fluid or toxic fumes can cause serious injury or death if splashed in the eyes or on the skin, inhaled, or swallowed.

- Know the specific hazards of the fluid you are using.
- Store hazardous fluid in an approved container. Dispose of hazardous fluid according to all local, state and national guidelines.
- Always wear protective eyewear, gloves, clothing and respirator as recommended by the fluid and solvent manufacturer.

Installation

NOTES:

- Reference numbers and letters in parentheses in the text refer to the callouts in the figures and drawings.
- Always use Genuine Graco Parts and Accessories, available from your Graco distributor. If you supply your own accessories, be sure they are adequately sized and pressure-rated to meet the system's requirements.
- Fig. 2 is only a guide for selecting and installing system components and accessories. Contact your Graco distributor for assistance in designing a system to suit your particular needs.

Prepare the Operator

All persons who operate the equipment must be trained in the safe, efficient operation of all system components as well as the proper handling of all fluids. All operators must thoroughly read all instruction manuals, tags, and labels before operating the equipment.

Prepare the Site

Ensure that you have an adequate compressed air supply. Refer to the performance charts on pages 21 and 23 to find the air consumption of your sprayer.

Mount the pump (A) to suit the type of installation planned. The pump dimensions and mounting hole layout are shown on page 19.

Keep the site clear of any obstacles or debris that could interfere with the operator's movement.

Have a grounded, metal pail available for use when flushing the system.

Grounding

⚠ WARNING

FIRE AND EXPLOSION HAZARD
Before operating the pump, ground the system as explained below. Also read the section **FIRE AND EXPLOSION HAZARD** on page 4.

- *Pump:* Use a ground wire and clamp. See Fig.1. Loosen the grounding lug locknut (W) and washer (X). Insert one end of a 12 ga (1.5 mm²) minimum ground wire (Y) into the slot in lug (Z) and tighten the locknut securely. Connect the other end of the wire to a true earth ground. For a ground wire and clamp, order Part No. 237569.

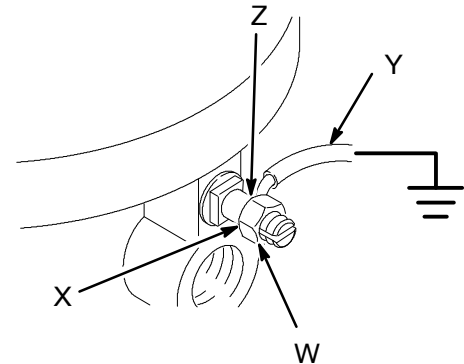

Fig. 1

0720

- *Air and fluid hoses:* Use only electrically conductive hoses with 500 ft (150 m) maximum combined hose length to ensure grounding continuity.
- *Air compressor:* Follow manufacturer's recommendations.
- *Spray gun or dispensing valve:* Connect to a properly grounded fluid hose and pump.
- *Object being sprayed:* Follow your local code.
- *Fluid supply container:* Follow your local code.
- *Solvent pails used when flushing:* Follow your local code. Use only metal pails, which are conductive, placed on a grounded surface. Do not place the pail on a nonconductive surface, such as paper or cardboard, which interrupts the grounding continuity.
- *To maintain proper grounding continuity when flushing or relieving pressure,* always hold the metal part of the spray gun firmly to the side of a grounded *metal* pail, then trigger the gun.

Installation

Typical Installation

KEY

- A Pump
- B Wall bracket
- C Air line lubricator
- D Bleed-type master air valve (required for pump)
See Warning on page 7 for part number.
- E Pump air regulator
- F Air line filter
- G Bleed-type master air valve (for accessories)
- H Electrically conductive air supply hose
- J Fluid drain valve (required)
See Warning on page 7 for part numbers.
- K Fluid filter
- L Electrically conductive fluid supply hose
- M Spray gun
- N Fluid suction hose
- P Air Line Moisture Trap and Drain Valve
- Y Ground wire (required)
Part No. 237569. See page 5 for installation instructions.

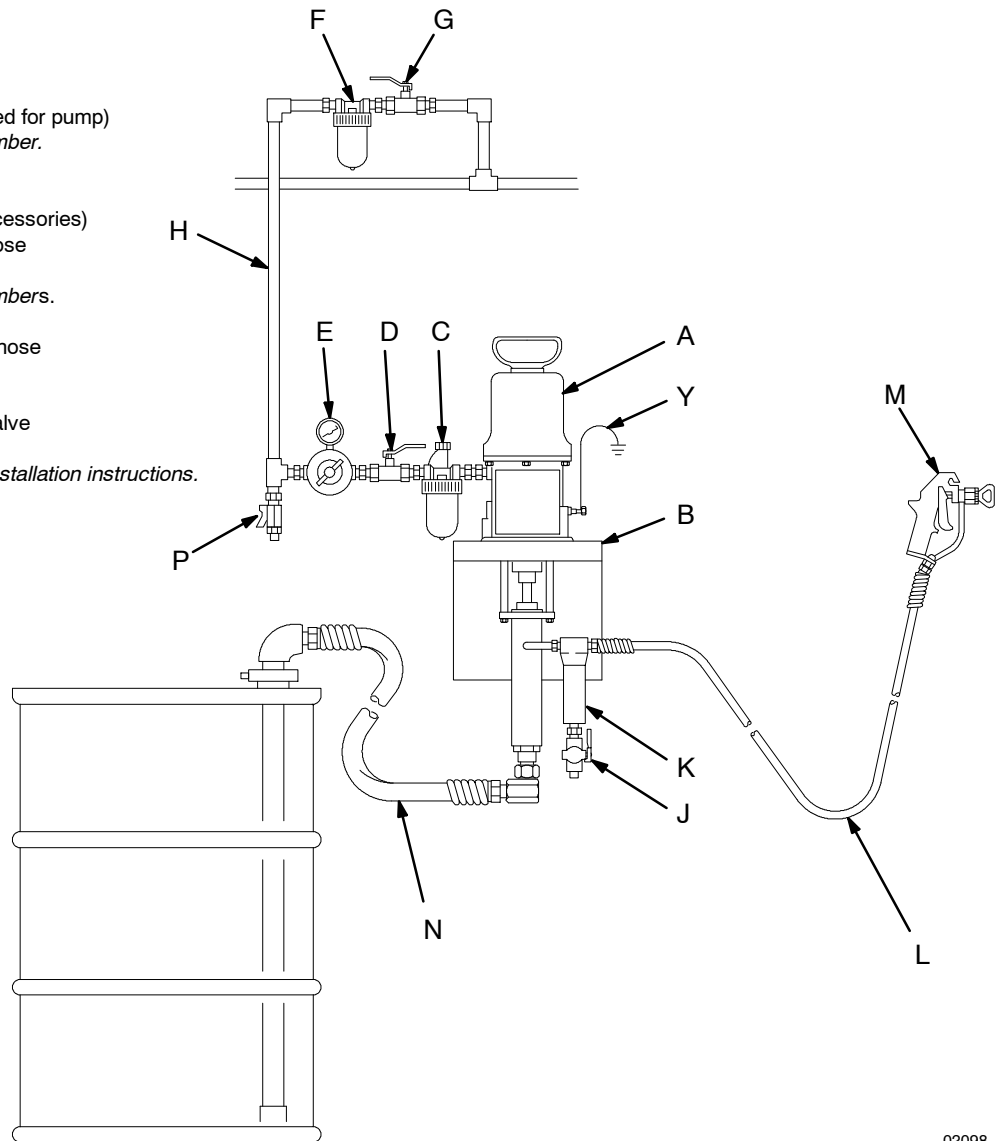

Fig. 2

02098

Installation

System Accessories

WARNING

A bleed-type master air valve (D) and a fluid drain valve (J) are required in your system. These accessories help reduce the risk of serious injury including skin injection, splashing in the eyes or on the skin, and injury from moving parts if you are adjusting or repairing the pump.

The bleed-type master air valve relieves air trapped between this valve and the pump after the air is shut off. Trapped air can cause the pump to cycle unexpectedly. Locate the valve close to the pump. Order Part No. 113333.

The fluid drain valve assists in relieving fluid pressure in the displacement pump, hose, and gun. Triggering the gun to relieve pressure may not be sufficient. Order one of the following:

Part No.	Description
238635	1/4 npt (mbe), carbon steel
210657	1/4 npt (mbe), carbon steel
210658	3/8 npt (mbe), carbon steel
210659	1/4 npt x 3/8 npt (mbe), carbon steel
239018	1/4 npt (mbe), stainless steel
235992	1/4 npt x 3/8 npt (mbe), stainless steel

Air and Fluid Hoses

Be sure all air and fluid hoses are properly sized and pressure-rated for your system. Use only electrically conductive air and fluid hoses. Use a 1/2 in. (13 mm) I.D. (minimum) air hose (H) to supply air to the pump.

Fluid hoses must have spring guards on both ends. Connect a fluid hose (L) to the pump's 3/8 npt(f) fluid outlet. Use of a short whip hose between the main fluid hose and the gun (M) allows freer gun movement. Connect a fluid suction hose or tube (N) to the pump's 3/4 npt(m) fluid intake.

Air Line Accessories

Install the following accessories in the order shown in Fig. 2, using adapters as necessary:

- **Air line lubricator (C)**
Provides automatic air motor lubrication.
- **Bleed-type master air valve (D)**
Required in your system to relieve air trapped between it and the air motor when the valve is closed (see the **WARNING** at left). Be sure the bleed valve is easily accessible from the pump, and is located **downstream** from the air regulator (E).
- **Air regulator (E)**
Controls pump speed and outlet pressure by adjusting the air pressure to the pump. Locate the regulator close to the pump, but **upstream** from the bleed-type master air valve (D).
- **Air line filter (F)**
Install an air line filter (F) and a moisture trap and drain valve (P) to help remove moisture and contaminants from the compressed air supply.
- **Second bleed-type air valve (G)**
Isolates the air line accessories for servicing. Locate upstream from all other air line accessories.

Fluid Line Accessories

Install the following accessories in the positions shown in Fig. 2, using adapters as necessary:

- **Fluid drain valve (J)**
Required in your system to relieve fluid pressure in the hose and gun (see the **WARNING** at left). Install the drain valve so that it points down and the handle points up when it is opened.
- **Fluid filter (K)**
Filters harmful particles from the fluid.
- **Spray gun (M)**
Dispenses the fluid. The gun shown in Fig. 2 is an airless spray gun.

Operation

Pressure Relief Procedure

WARNING



SKIN INJECTION HAZARD

The system pressure must be manually relieved to prevent the system from starting or spraying accidentally. Fluid under high pressure can be injected through the skin and cause serious injury. To reduce the risk of an injury from injection, splashing fluid, or moving parts, follow the **Pressure Relief Procedure** whenever you:

- are instructed to relieve the pressure,
- stop spraying,
- check or service any of the system equipment,
- or install or clean the spray tip.

1. Lock the gun trigger safety.
2. Shut off the air supply to the pump.
3. Close the bleed-type master air valve (required in your system).
4. Unlock the gun trigger safety.
5. Hold a metal part of the gun firmly to the side of a grounded metal pail, and trigger the gun to relieve pressure.
6. Lock the gun trigger safety.
7. Open the drain valve (required in your system), and have a container ready to catch the drainage.
8. Leave the drain valve open until you are ready to spray again.

*If you suspect that the spray tip or hose is completely clogged, or that pressure has not been fully relieved after following the steps above, **very slowly** loosen the tip guard retaining nut or hose end coupling and relieve pressure gradually, then loosen it completely. Then clear the tip or hose.*

Flush the Pump Before First Use

The pump is tested with lightweight oil, which is left in to protect the pump parts. If the fluid you are using may be contaminated by the oil, flush it out with a compatible solvent before using the pump. If the pump is being used to supply a circulating system, allow the solvent to circulate until the pump is thoroughly flushed. See **Flushing the Pump** on page 9.

Packing Nut/Wet-Cup

WARNING

To reduce the risk of serious injury whenever you are instructed to relieve pressure, always follow the **Pressure Relief Procedure** at left.

Keep the packing nut/wet-cup (104) filled with Graco Throat Seal Liquid (TSL) or compatible solvent to help prolong the packing life. Ensure weekly that the packing nut is torqued to 18 to 20 ft-lb (24 to 27 N.m); do not overtighten it. See Fig. 3 on page 11. Relieve the pressure before adjusting the packing nut or adding TSL.

Starting and Adjusting the Pump

Begin these steps **before** you install the spray tip.

1. Ensure that the air regulator (E) and bleed-type master air valve (D) are closed. See Fig. 2 on page 6.
2. Connect a suction hose (N) to the pump's fluid inlet, or lower the pump into a fluid supply container.
3. Hold a metal part of the spray gun (M) firmly to the side of a grounded metal pail and hold the trigger open.
4. Open the pump's bleed-type master air valve (D).
5. Slowly open the air regulator (E) until the pump starts (approximately 40 psi [0.28 MPa, 2.8 bar]).
6. Cycle the pump slowly until all the air is pushed out and the pump and hoses are fully primed.
7. Release the spray gun trigger and lock the trigger safety. The pump should stall against pressure when you release the trigger.

WARNING

To reduce the risk of serious injury whenever you are instructed to relieve pressure, always follow the **Pressure Relief Procedure** at left.

8. Relieve the pressure.
9. Install the spray tip in the gun.

Continued on page 9.

Operation

WARNING

COMPONENT RUPTURE HAZARD



To reduce the risk of overpressurizing your system, which could cause component rupture and serious injury, *never exceed the specified maximum air input pressure to the pump* (see **Technical Data** on page 20).

- Control the pump speed and fluid pressure with the air regulator (E). Always use the lowest air pressure necessary to get the desired results. Higher pressure causes premature spray tip and pump wear.
- With the pump and lines primed, and with adequate air pressure and volume supplied, the pump starts and stops as the spray gun is opened and closed. In a circulating system, the pump runs continuously and speeds up or slows down as supply increases or decreases until the air supply is shut off.

CAUTION

Never allow the pump to run dry of the fluid being pumped. A dry pump will quickly accelerate to a high speed, possibly damaging itself. If your pump accelerates quickly, or is running too fast, stop it immediately and check the fluid supply. If the supply container is empty and air has been pumped into the lines, refill the container and prime the pump and the lines with fluid, or flush and leave it filled with a compatible solvent. Be sure to eliminate all air from the fluid system.

Shutdown and Care of the Pump

WARNING

To reduce the risk of serious injury whenever you are instructed to relieve pressure, always follow the **Pressure Relief Procedure** on page 8.

For overnight shutdown, relieve the pressure, and always stop the pump at the bottom of the stroke to prevent the fluid from drying on the exposed displacement rod and damaging the throat packings.

Always flush the pump before the fluid dries on the displacement rod. See **Flushing the Pump**.

Flushing the Pump

WARNING



FIRE AND EXPLOSION HAZARD

Before flushing, read the section **FIRE AND EXPLOSION HAZARD** on page 4. Be sure the entire system and flushing pails are properly grounded. Refer to **Grounding** on page 5.

Flush with a fluid that is compatible with the fluid you are pumping and with the wetted parts in your system. Check with your fluid manufacturer or supplier for recommended flushing fluids and flushing frequency. Always flush the pump before fluid dries on the displacement rod.

CAUTION

Never leave water or water-base fluid in the pump overnight. If you are pumping water-base fluid, flush with water first, then with a rust inhibitor such as mineral spirits. Relieve the pressure, but leave the rust inhibitor in the pump to protect the parts from corrosion.

WARNING

To reduce the risk of serious injury whenever you are instructed to relieve pressure, always follow the **Pressure Relief Procedure** on page 8.

- Relieve the pressure.
- Remove the spray tip from the gun.
- Hold a metal part of the gun firmly to the side of a grounded *metal* pail.
- Start the pump. Always use the lowest possible fluid pressure when flushing.
- Trigger the gun.
- Flush the system until clear solvent flows from the gun.
- Relieve the pressure.

Troubleshooting

WARNING

To reduce the risk of serious injury whenever you are instructed to relieve pressure, always follow the **Pressure Relief Procedure** on page 8.

1. Relieve the pressure.
2. Check all possible problems and solutions before disassembling pump.

Problem	Cause	Solution
Pump fails to operate.	Restricted line or inadequate air supply.	Clear; increase air supply.
	Insufficient air pressure; closed or clogged air valves, etc.	Open; clean (be sure to use air filter).
	Exhausted fluid supply.	Refill; purge all air from pump and fluid lines.
	Damaged air valve; stalling.	Service air motor (see air motor manual, supplied).
	Dried fluid seizure of displacement rod (103).	Clean, check or replace throat packings (114, 123); always stop pump at bottom of stroke and keep wet-cup filled with compatible solvent.
Pump operates but output is low on both strokes.	Restricted line or inadequate air supply.	Clear; increase air supply.
	Insufficient air pressure; closed or clogged air valves, etc.	Open; clean (be sure to use air filter).
	Exhausted fluid supply.	Refill; purge all air from pump and fluid lines.
	Clogged fluid line, valves, etc.	Clear* (be sure to use fluid filter).
	Packing nut (104) is too tight.	Loosen (see page 8).
	Loose packing nut (104) or worn throat packings (114, 123).	Tighten packing nut (see page 8); replace throat packings.
Pump operates but output is low on downstroke.	Held open or worn intake valve.	Clear; service. See page 12.
Pump operates but output is low on upstroke.	Held open or worn fluid piston valve or packings (115, 124).	Clear; service. See page 12.
Erratic or accelerated operation.	Exhausted fluid supply.	Refill; purge all air from pump and fluid lines.
	Held open or worn intake valve.	Clear; service. See page 12.
	Held open or worn fluid piston valve or packings (115, 124).	Clear; service. See page 12.

* To determine if the fluid hose or gun is obstructed, relieve the pressure and disconnect the fluid hose, and place a container at the pump fluid outlet to catch any fluid. Turn on the air just enough to start the pump (about 20 to 40 psi [0.14 to 0.28 MPa, 1.4 to 2.8 bar]). If the pump starts when the air is turned on, the obstruction is in the fluid hose or gun.

Service

Disconnecting the Displacement Pump

⚠ WARNING

To reduce the risk of serious injury whenever you are instructed to relieve pressure, always follow the **Pressure Relief Procedure** on page 8.

1. Flush the pump if possible. Stop the pump at the bottom of its stroke. Relieve the pressure.
2. Disconnect the air and fluid hoses. Remove the pump from its mounting. Note the relative position of the fluid outlet (R) to the air inlet (S). See Fig. 3.
3. Unscrew the tie rod locknuts (4) from the tie rods (10). Remove the cotter pin (3). Carefully pull the displacement pump (13) off the air motor (12). Unscrew the displacement rod (103) from the air motor (12) or adapter (5, President Pump only). Inspect the o-ring (6).
4. Refer to page 12 for displacement pump service. To service the air motor, refer to the separate air motor manual, which is supplied.

Reconnecting the Displacement Pump

1. Lubricate the o-ring (6) and check that it is in place on the displacement rod (103).
2. Orient the fluid outlet (R) to the air inlet (S) as noted in step 2 under **Disconnecting the Displacement Pump**. Position the displacement pump (13) on the tie rods (10). See Fig. 3.
3. Screw the displacement rod (103) into the shaft of the air motor (12) or the adapter (5, President Pump only) until the pin holes are aligned. Screw the locknuts (4) onto the tie rods (10) loosely. Install the cotter pin (3).
4. Mount the pump and reconnect all hoses. Reconnect the ground wire if it was disconnected during repair. Torque the packing nut (104) to 18 to 20 ft-lb (24 to 27 N.m). Fill the wet-cup with Graco Throat Seal Liquid or compatible solvent.
5. Tighten the tie rod locknuts (4) evenly, and torque as specified in Fig. 3. Start the pump and run it at about 40 psi (0.28 MPa, 2.8 bar) air pressure, to check that it is operating properly.

**Monark Models
223596 (shown)
and 237958**

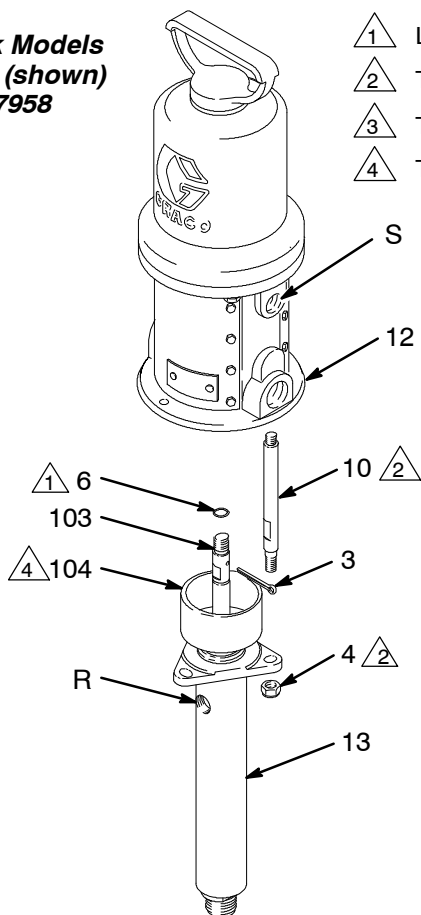

**President Model
239140 (shown)**

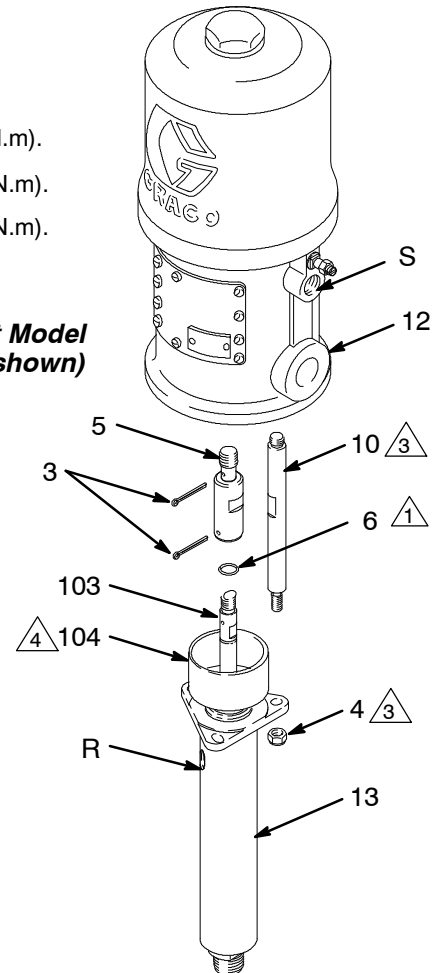

Fig. 3

02099

06938

Service

Displacement Pump Service

Disassembling

When disassembling the pump, lay out all removed parts in sequence to make reassembling easier. Refer to Fig. 4.

NOTE: Repair Kits and Conversion Kits are available. Refer to the parts list for your pump (pages 14 to 17). For the best results, use all the new parts in the kit. Parts included in the kit are marked with one asterisk (for example, 3*).

Clean all the parts thoroughly when disassembling. Check them carefully for damage or wear, and replace parts as needed.

1. Remove the displacement pump from the air motor as explained on page 11.
2. Unscrew the intake valve housing (105) from the outlet housing (107). If it is difficult to remove, squirt penetrating oil around the threads and gently tap around the valve housing with a plastic hammer to loosen it.
3. Remove the ball stop pin (113), o-ring retainer (108), o-ring (109), ball guide (101), and ball (112).
4. Loosen the packing nut (104). Push the displacement rod (103) down as far as possible, and pull it out of the outlet housing (107), being careful not to scratch the sleeve (106).
5. Secure the flats of the piston stud (102) in a vise. Screw the displacement rod (103) off the piston stud. Remove the ball (110), retainer (122), packings (124, 115), and glands (117, 121).
6. Remove the packing nut (104), throat packings (123, 114), glands (116, 118), and washer (119) from the outlet housing (107).
7. Inspect all parts for damage. Clean all parts and threads with a compatible solvent before reassembling. Inspect the polished surfaces of the displacement rod (103) and sleeve (106) for scratches, scoring, or other damage, which can cause premature packing wear and leaking. To check, run a finger over the surface or hold the part up to the light at an angle. Replace any worn or damaged parts.

NOTE: If the sleeve (106) needs replacement and is hard to remove, contact your Graco distributor.

Reassembling

1. Lubricate the throat packings (114*, 123*). Install the throat packing parts in the outlet housing (107) one at a time, in the order shown in Detail A of Fig. 4. *Be sure the lips of the v-packings face down, lubricate the packing nut threads, and install the packing nut finger tight.*
2. If you removed the sleeve (106), reinstall it in the outlet housing (107), making sure to install the new gasket (120*). To install the gasket, lay it flat in the outlet housing (107) and use the sleeve to seat the gasket against the shoulder of the outlet housing. *Be sure the tapered end of the sleeve faces down, toward the pump intake.*
3. Lubricate the piston packings (115*, 124*). Install the piston packing parts on the piston stud (102) one at a time, in the order shown in Detail B of Fig. 4. *Be sure the lips of the v-packings face up, toward the threads of the piston stud.*
4. Place the flats of the piston stud in a vise. Install the piston ball (110*) on the piston and screw the displacement rod (103) onto the piston valve assembly. Torque to 35 to 40 ft-lb (47 to 54 N.m).
5. Insert the displacement rod (103) into the bottom of the outlet housing (107), being careful not to scratch the sleeve (106). Push the rod straight up until it protrudes from the packing nut (104).
6. Install the ball (112*), guide (101), o-ring (109*), retainer (108), and ball stop pin (113) in the intake valve housing (105). Lubricate the intake valve housing threads, and screw the intake valve housing into the outlet housing (107). Torque to 55 to 65 ft-lb (75 to 88 N.m).
7. Reconnect the displacement pump to the air motor as explained on page 11.

Service

- △₁ Lubricate.
- △₂ Install the throat packings in the following order, with the lips of the v-packings facing down: washer (119), male gland (118*), four leather v-packings (114*), one PTFE v-packing (123*), female gland (116*), and the packing nut (104), *install finger tight*.
- △₃ Tapered end of sleeve (106) must face down toward pump intake.

- △₄ Install the piston packings in the following order, with the lips of the v-packings facing up: female gland (121*), one PTFE v-packing (124*), four leather v-packings (115*), male gland (117*), and packing retainer (122*).
- △₆ Torque to 35 to 40 ft-lb (47 to 54 N.m).
- △₇ Torque to 55 to 65 ft-lb (75 to 88 N.m).
- △₈ See **Reconnecting the Displacement Pump** on page 11 for instructions on when to torque the packing nut to 18 to 20 ft-lb (24 to 27 N.m).

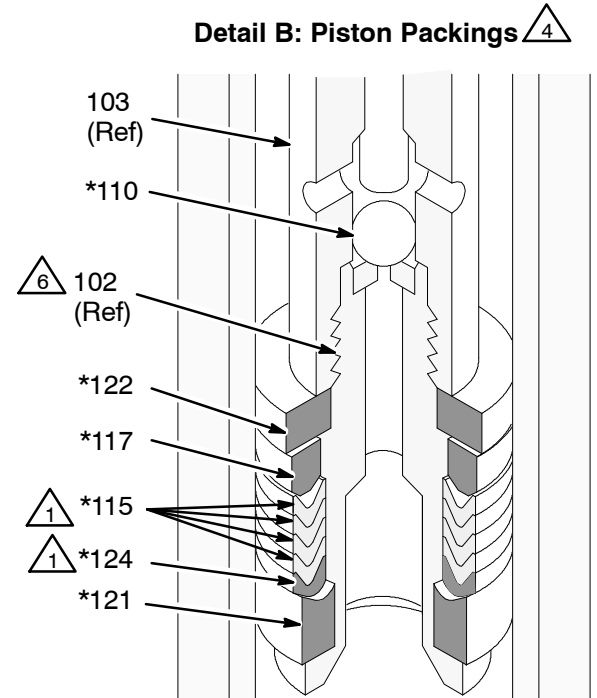
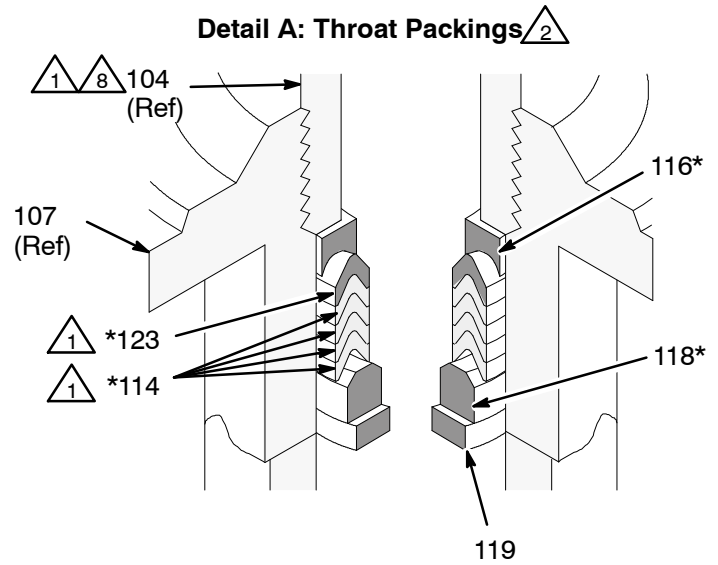
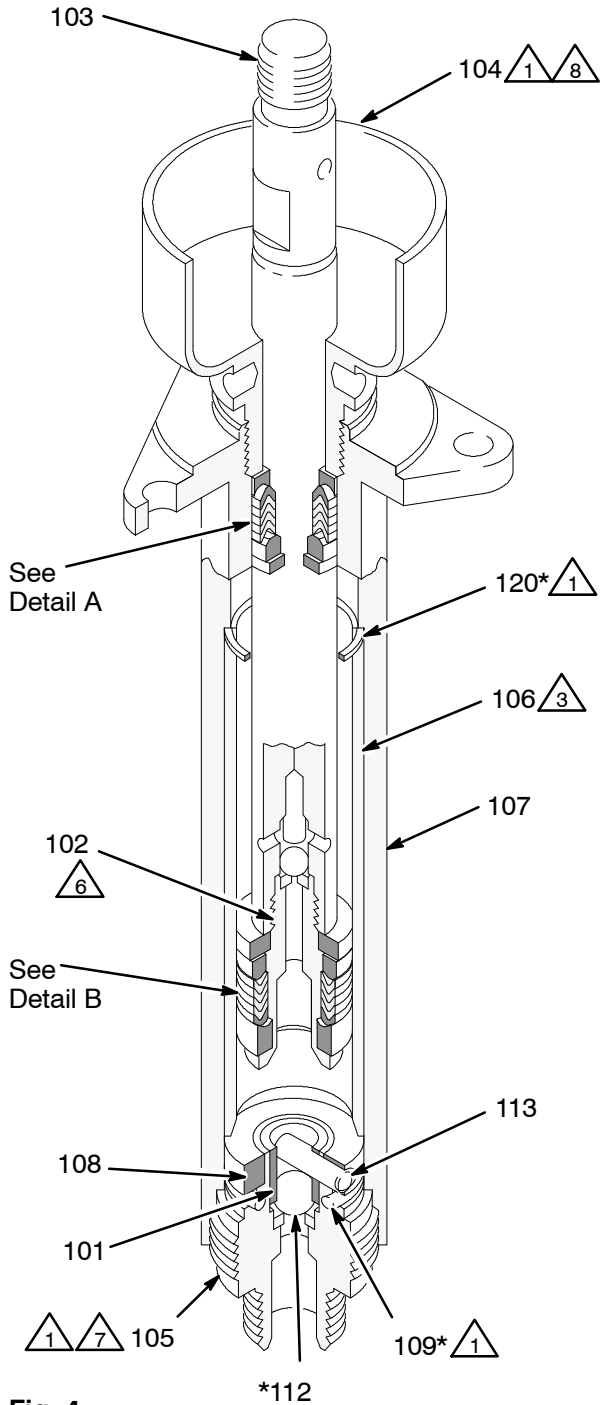

Fig. 4

06937

Parts

Model 223596, Series B, 23:1 Ratio CST Monark® Pump (shown)

includes items 3, 4, 6, 10, 12, and 13

Model 237958, Series B, 23:1 Ratio SST Monark® Pump

includes items 3, 4, 6, 10, 12, and 14

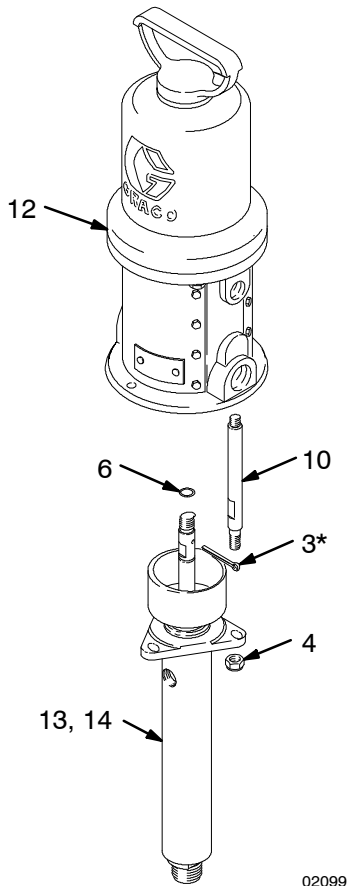

02099

Ref No.	Part No.	Description	Qty
3*	101946	PIN, cotter, stainless steel, 0.12 in. (3.2 mm) x 1.5 in. (38 mm)	1
4	101566	NUT, lock, 3/8-16	3
6	154771	SEAL, o-ring, buna-N	1
10	164722	ROD, tie, carbon steel, 4.375 in. (112 mm) shoulder-to-shoulder	3
12	222791	AIR MOTOR see 307043 for parts	1
13	223595	DISPLACEMENT PUMP ASSY, carbon steel, for pump Model 223596 see page 15 for parts.	1
14	239145	DISPLACEMENT PUMP ASSY, stainless steel, for pump Model 237958 (not shown) see page 17 for parts.	1

* This part is included in Repair Kit 239328 (Model 223596) or Repair Kit 235636 (Model 237958), which may be purchased separately. See page 15 or page 17 for additional kit parts.

Parts

Model 223595, Series D

Carbon steel severe-duty displacement pump with stainless steel glands, intake housing, piston valve, and ball stop

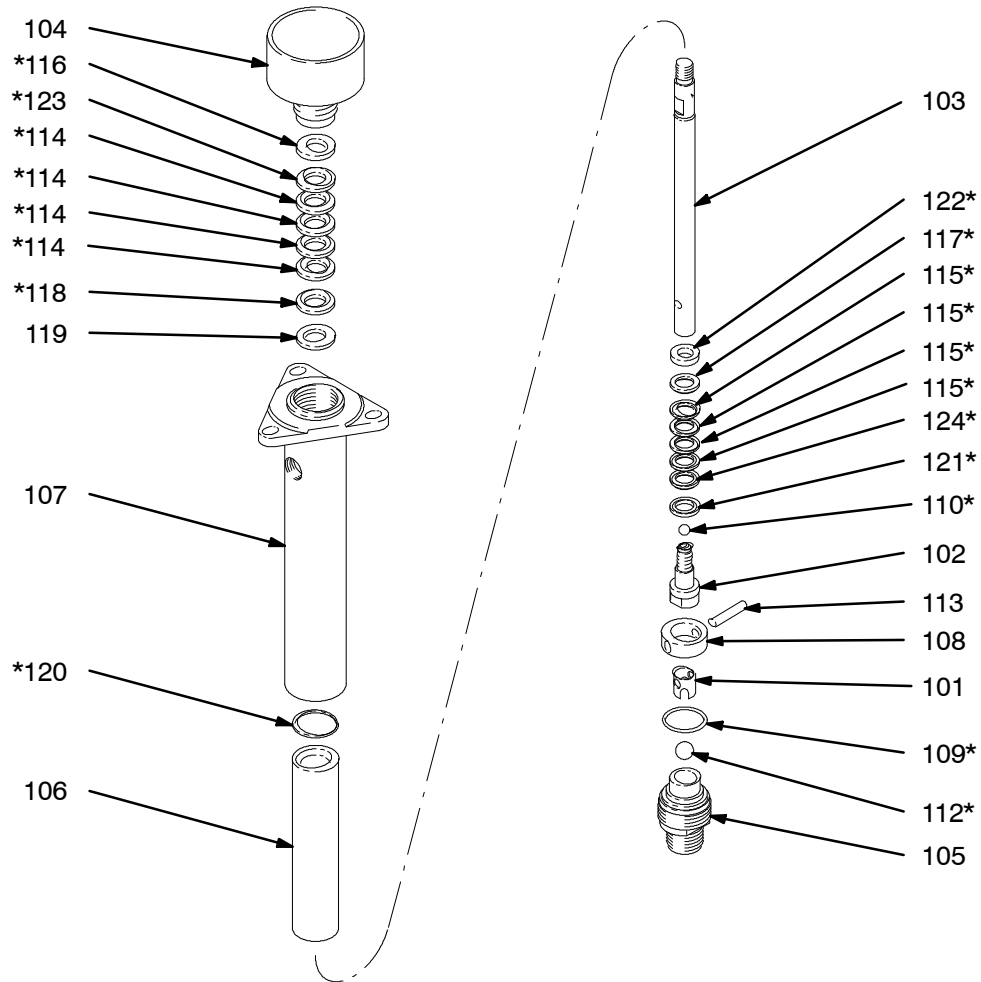

02101A

Ref No.	Part No.	Description	Qty	Ref No.	Part No.	Description	Qty
101	186187	GUIDE, ball, intake, stainless steel	1	114*	164397	V-PACKING, throat, leather	4
102	223591	STUD, piston, stainless steel with tungsten carbide seat	1	115*	184300	V-PACKING, piston, leather	4
103	24C508	ROD, displacement, stainless steel	1	116*	186194	GLAND, throat, female, stainless steel	1
104	206269	PACKING NUT/WET-CUP, CST	1	117*	186195	GLAND, piston, male, stainless steel	1
105	223593	HOUSING, valve, intake, SST with tungsten carbide seat	1	118*	186196	GLAND, throat, male, stainless steel	1
106	24C499	SLEEVE, housing, stainless steel	1	119	186197	WASHER, flat, stainless steel	1
107	207011	HOUSING, outlet, carbon steel	1	120*	164480	GASKET, flat, PTFE	1
108	186183	RETAINER, o-ring, stainless steel	1	121*	186198	GLAND, piston, female, stainless steel	1
109*	165052	O-RING, PTFE	1	122*	186199	RETAINER, packing, stainless steel	1
110*	105444	BALL, 440C stainless steel, 0.31 in. (7.9 mm) dia.	1	123*	164913	V-PACKING, throat, PTFE	1
112*	105445	BALL, 440C stainless steel, 0.5 in. (13 mm) dia.	1	124*	164912	V-PACKING, piston, PTFE	1
113	186179	PIN, ball stop, intake, stainless steel	1	125 ▲	172479	TAG, warning (not shown)	1

* These parts are included in Repair Kit 239328, which may be purchased separately. See page 14 for additional parts.

▲ Replacement danger and warning labels, tags, and cards are available for free.

Parts

**Model 239140, Series A,
46:1 Ratio SST President® Pump**
includes items 3, 4, 5, 6, 10, 12, and 13

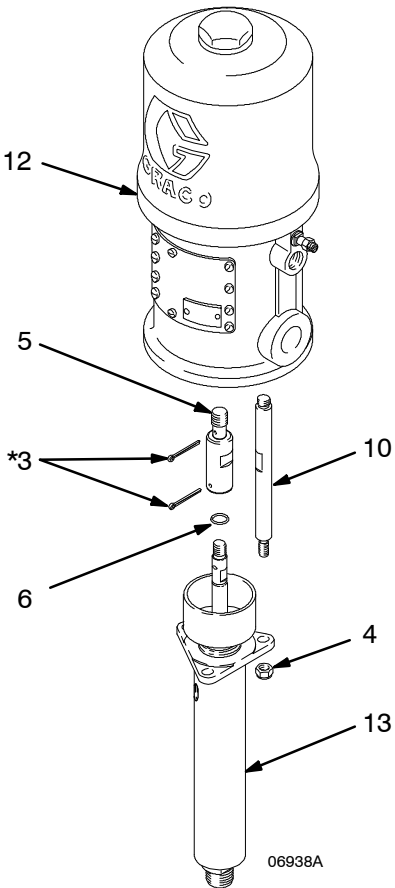

Ref No.	Part No.	Description	Qty
3*	101946	PIN, cotter, stainless steel, 0.12 in. (3.2 mm) x 1.5 in. (38 mm)	2
4	101566	NUT, lock, 3/8-16	3
5	191995	ADAPTER	1
6	154771	SEAL, o-ring, buna-N	1
10	191996	ROD, tie, carbon steel, 6 in. (152 mm) shoulder-to-shoulder	3
12	207352	AIR MOTOR See 306982 for parts	1
13	239145	DISPLACEMENT PUMP ASSY, stainless steel, <i>see page 17 for parts.</i>	1
17	307619	MANUAL, instructions	1

* *This part is included in Repair Kit 235636, which may be purchased separately. See page 17 for additional kit parts.*

Parts

Model 239145, Series A

Stainless steel severe-duty displacement pump

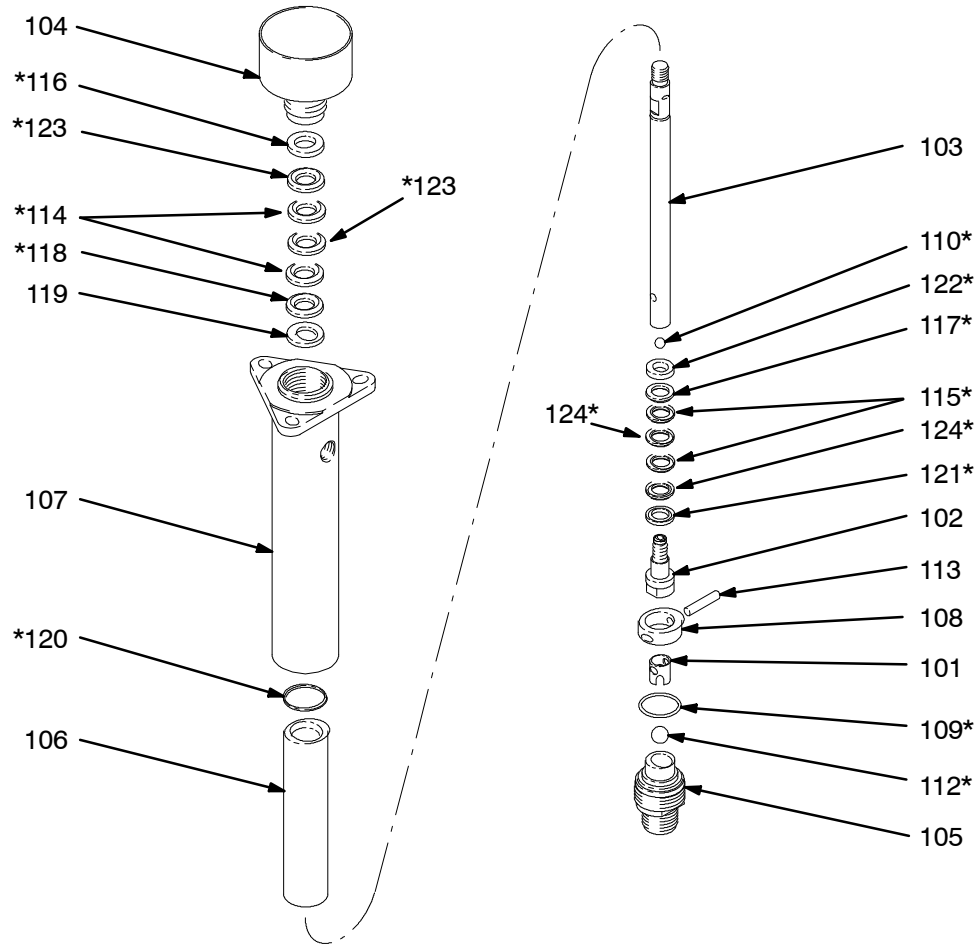

06935

Ref No.	Part No.	Description	Qty	Ref No.	Part No.	Description	Qty
101	186187	GUIDE, ball, intake, stainless steel	1	113	186179	PIN, ball stop, intake, stainless steel	1
102	223591	STUD, piston, stainless steel with tungsten carbide seat	1	114*	164397	V-PACKING, throat, leather	2
103	24C508	ROD, displacement, stainless steel	1	115*	164715	V-PACKING, piston, leather	2
104	223590	PACKING NUT/WET-CUP, stainless steel	1	116*	186194	GLAND, throat, female, stainless steel	1
105	223593	HOUSING, valve, intake, stainless steel with tungsten carbide seat	1	117*	186195	GLAND, piston, male, stainless steel	1
106	24C499	SLEEVE, housing, stainless steel	1	118*	186196	GLAND, throat, male, stainless steel	1
107	239137	HOUSING, outlet, stainless steel	1	119	186197	WASHER, flat, stainless steel	1
108	186183	RETAINER, o-ring, stainless steel	1	120*	164480	GASKET, flat, PTFE	1
109*	165052	O-RING, PTFE	1	121*	186198	GLAND, piston, female, stainless steel	1
110*	105444	BALL, 440C SST, 0.31 in. (7.9 mm) dia.	1	122*	186199	RETAINER, packing, stainless steel	1
112*	105445	BALL, 440C SST, 0.5 in. (13 mm) dia.	1	123*	164913	V-PACKING, throat, PTFE	2
				124*	164912	V-PACKING, piston, PTFE	2
				125 ▲	172479	TAG, warning (not shown)	1

* These parts are included in Repair Kit 235636, which may be purchased separately. See page 16 for additional parts.

▲ Replacement danger and warning labels, tags, and cards are available for free.

Conversion Kits

PTFE Conversion Kit 236724

For converting pumps to all PTFE packings. Must be purchased separately.

Part No.	Description	Qty
101946	PIN, cotter, stainless steel	1
101545	PIN, cotter (for old-style ball checks)	1
165052	O-RING, PTFE	1
105444	BALL, 440C stainless steel, 0.31 in. (7.9 mm) dia.	1
105445	BALL, 440C stainless steel, 0.5 in. (13 mm) dia.	1
186194	GLAND, throat, female, stainless steel	1
186195	GLAND, piston, male, stainless steel	1
186196	GLAND, throat, male, stainless steel	1
186198	GLAND, piston, female, stainless steel	1
186199	RETAINER, packing, stainless steel	1
164912	V-PACKING, piston, PTFE	4
164913	V-PACKING, throat, PTFE	4

UHMWPE/Leather Conversion Kit 223674

For converting pumps to UHMWPE and leather packings. Must be purchased separately.

Part No.	Description	Qty
101946	PIN, cotter, stainless steel	1
101545	PIN, cotter (for old-style ball checks)	1
165052	O-RING, PTFE	1
105444	BALL, 440C stainless steel, 0.31 in. (7.9 mm) dia.	1
105445	BALL, 440C stainless steel, 0.5 in. (13 mm) dia.	1
164397	V-PACKING, throat, leather	2
164715	V-PACKING, piston, leather	2
186194	GLAND, throat, female, stainless steel	1
186195	GLAND, piston, male, stainless steel	1
186196	GLAND, throat, male, stainless steel	1
186198	GLAND, piston, female, stainless steel	1
186199	RETAINER, packing, stainless steel	1
108455	V-PACKING, throat, UHMWPE	2
108456	V-PACKING, piston, UHMWPE	2

PTFE/Leather Conversion Kit 235636

For converting pumps to PTFE and leather packings. This is the standard repair kit for Model 223595 Displacement Pump, Series C and earlier. Must be purchased separately.

Part No.	Description	Qty
101946	PIN, cotter, stainless steel	1
101545	PIN, cotter (for old-style ball checks)	1
165052	O-RING, PTFE	1
105444	BALL, 440C stainless steel, 0.31 in. (7.9 mm) dia.	1
105445	BALL, 440C stainless steel, 0.5 in. (13 mm) dia.	1
164397	V-PACKING, throat, leather	2
164715	V-PACKING, piston, leather	2
186194	GLAND, throat, female, stainless steel	1
186195	GLAND, piston, male, stainless steel	1
186196	GLAND, throat, male, stainless steel	1
186198	GLAND, piston, female, stainless steel	1
164480	GASKET, PTFE	1
186199	RETAINER, packing, stainless steel	1
164912	V-PACKING, piston, PTFE	2
164913	V-PACKING, throat, PTFE	2

PTFE/Leather Conversion Kit 239328

For converting pumps to leather packings. Must be purchased separately.

Part No.	Description	Qty
101946	PIN, cotter, stainless steel	1
101545	PIN, cotter (for old-style ball checks)	1
165052	O-RING, PTFE	1
105444	BALL, 440C stainless steel, 0.31 in. (7.9 mm) dia.	1
105445	BALL, 440C stainless steel, 0.5 in. (13 mm) dia.	1
164397	V-PACKING, throat, leather	4
184300	V-PACKING, piston, leather	4
186194	GLAND, throat, female, stainless steel	1
186195	GLAND, piston, male, stainless steel	1
186196	GLAND, throat, male, stainless steel	1
186198	GLAND, piston, female, stainless steel	1
164480	GASKET, PTFE	1
186199	RETAINER, packing, stainless steel	1
164912	V-PACKING, piston, PTFE	1
164913	V-PACKING, throat, PTFE	1

Dimensions

Model 223596 shown

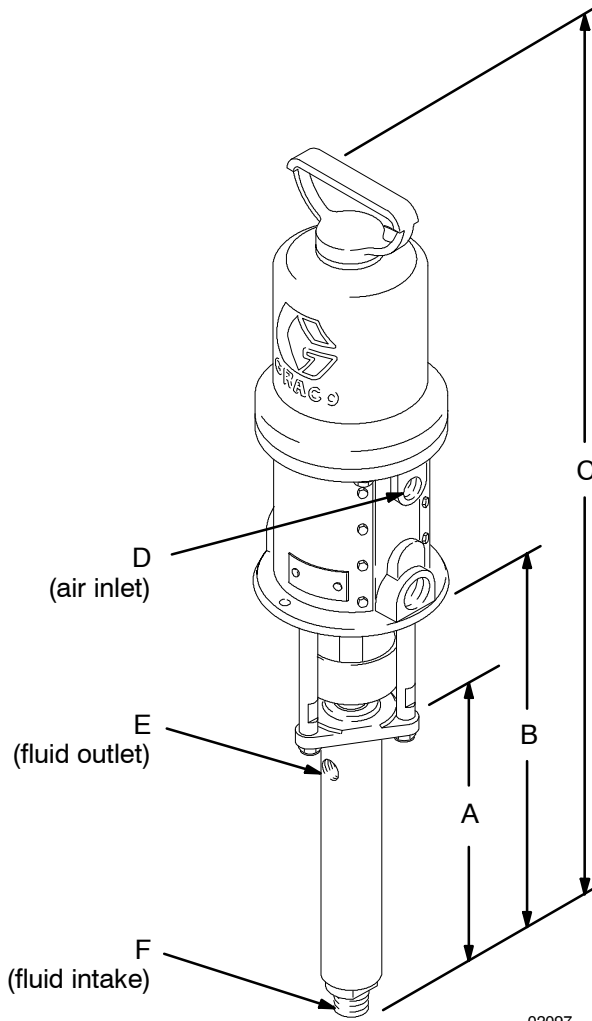

02097

Mounting Hole Layout

- A 4.38 in. (111.3 mm) diameter
- B 2.5 in. (64 mm)
- C 5.0 in. (127 mm)
- D 0.28 in. (7.1 mm) diameter

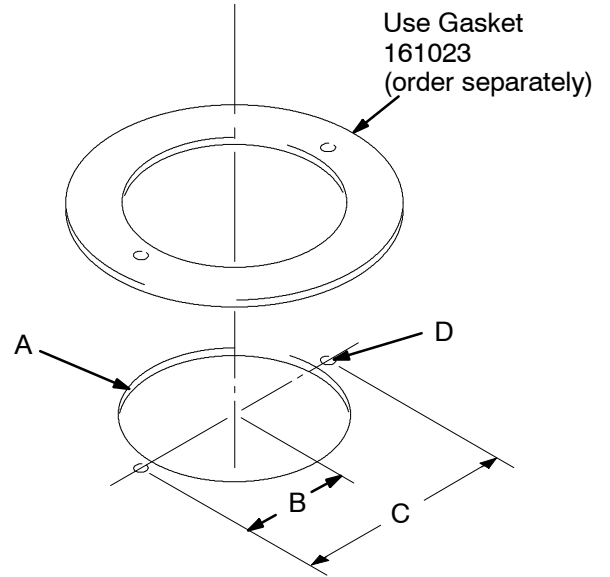

Dimension	Model 223596	Model 237958	Model 239140
A	10.8 in. (274 mm)	10.9 in. (277 mm)	10.8 in. (274 mm)
B	15.2 in. (386 mm)	15.2 in. (386 mm)	16.8 in. (426 mm)
C	28.8 in. (732 mm)	28.8 in. (732 mm)	31.6 in. (802 mm)
D	3/8 npt(f)	3/8 npt(f)	1/2 npt(f)
E	3/8 npt(f)	3/8 npt(f)	3/8 npt(f)
F	3/4 npt(m)	3/4 npt(m)	3/4 npt(m)

Technical Data

Category	Model 239140 SST President	Model 223596 CST Monark	Model 237958 SST Monark
Ratio	46:1	23:1	23:1
Maximum fluid working pressure	4600 psi (32 MPa, 317 bar)	2760 psi (19 MPa, 190 bar)	3450 psi (24 MPa, 238 bar)
Maximum air input pressure	100 psi (0.7 MPa, 7 bar)	120 psi (0.8 MPa, 8 bar)	150 psi (1.0 MPa, 10 bar)
Fluid flow at 60 cycles per minute	0.55 gpm (2.1 liters/min)	0.4 gpm (1.5 liters/min)	0.4 gpm (1.5 liters/min)
Maximum pump operating temperature	180°F (82°C)	180°F (82°C)	180°F (82°C)
Weight	approx. 24 lb (11 kg)	approx. 24 lb (11 kg)	approx. 24 lb (11 kg)
Wetted parts	AISI 304, 316, 440C, and 17-4 PH grades of stainless steel; tungsten carbide; PTFE; leather	carbon steel; AISI 304, 316, 420, 440C, and 17-4 PH grades of stainless steel; chrome; chrome and zinc plating; tungsten carbide; PTFE; leather	AISI 304, 316, 440C, and 17-4 PH grades of stainless steel; tungsten carbide; PTFE; leather

Sound Pressure Levels (dBa) (measured at 1 meter from unit)

Air Motor	Input Air Pressures at 15 cycles per minute		
	40 psi (0.28 MPa, 2.8 bar)	70 psi (0.48 MPa, 4.8 bar)	100 psi (0.7 MPa, 7 bar)
President	73.6 dB(A)	78.3 dB(A)	80.9 dB(A)
Monark	62.6 dB(A)	62.5 dB(A)	63.9 dB(A)

Sound Power Levels (dBa) (tested in accordance with ISO 9614-2)

Air Motor	Input Air Pressures at 15 cycles per minute		
	40 psi (0.28 MPa, 2.8 bar)	70 psi (0.48 MPa, 4.8 bar)	100 psi (0.7 MPa, 7 bar)
President	87.4 dB(A)	92.1 dB(A)	94.6 dB(A)
Monark	69.5 dB(A)	70.7 dB(A)	71.0 dB(A)

Technical Data

Model 223596 23:1 Ratio CST Monark Performance Chart

To find Fluid Outlet Pressure (psi/MPa/bar) at a specific fluid flow (lpm/gpm) and operating air pressure (psi/MPa/bar):

1. Locate desired flow along bottom of chart.
2. Follow vertical line up to intersection with selected fluid outlet pressure curve (black). Follow left to scale to read fluid outlet pressure.

- A 120 psi (0.8 MPa, 8 bar) air pressure
- B 70 psi (0.49 MPa, 4.9 bar) air pressure
- C 40 psi (0.28 MPa, 2.8 bar) air pressure

Monark 23:1 Fluid Outlet Pressure

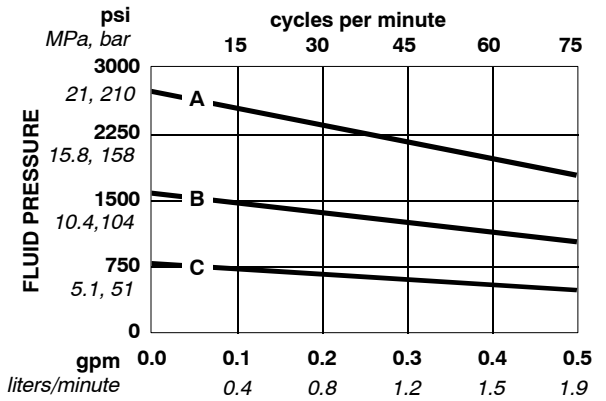

FLUID FLOW (TEST FLUID: NO. 10 WEIGHT OIL)

To find Pump Air Consumption (m³/min or scfm) at a specific fluid flow (lpm/gpm) and air pressure (psi/MPa/bar):

1. Locate desired flow along bottom of chart.
2. Read vertical line up to intersection with selected air consumption curve (dashes). Follow left to scale to read air consumption.

Monark 23:1 Air Consumption

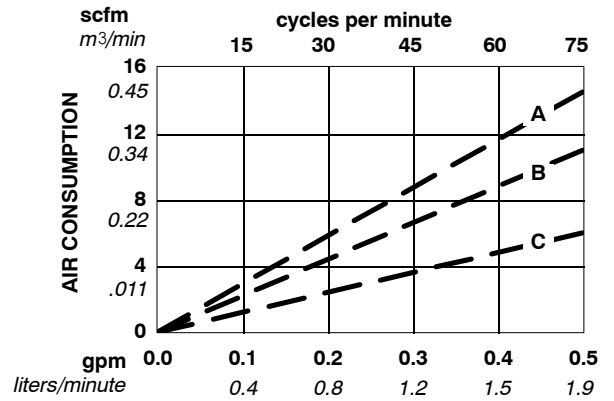

FLUID FLOW (TEST FLUID: NO. 10 WEIGHT OIL)

Model 237958 23:1 Ratio SST Monark Performance Chart

To find Fluid Outlet Pressure (psi/MPa/bar) at a specific fluid flow (lpm/gpm) and operating air pressure (psi/MPa/bar):

1. Locate desired flow along bottom of chart.
2. Follow vertical line up to intersection with selected fluid outlet pressure curve (black). Follow left to scale to read fluid outlet pressure.

- A 150 psi (1.0 MPa, 10 bar) air pressure
- B 70 psi (0.49 MPa, 4.9 bar) air pressure
- C 40 psi (0.28 MPa, 2.8 bar) air pressure

Monark 23:1 Fluid Outlet Pressure

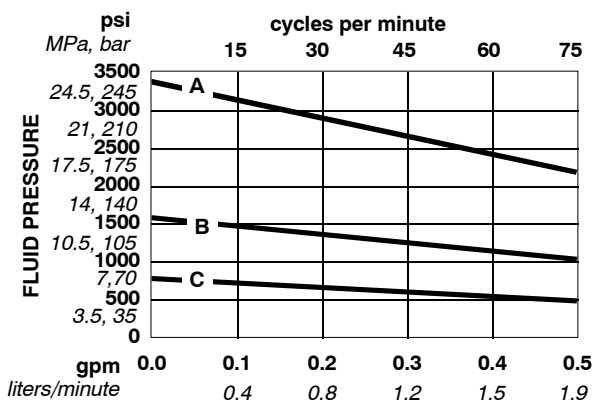

FLUID FLOW (TEST FLUID: NO. 10 WEIGHT OIL)

To find Pump Air Consumption (m³/min or scfm) at a specific fluid flow (lpm/gpm) and air pressure (psi/MPa/bar):

1. Locate desired flow along bottom of chart.
2. Read vertical line up to intersection with selected air consumption curve (dashes). Follow left to scale to read air consumption.

Monark 23:1 Air Consumption

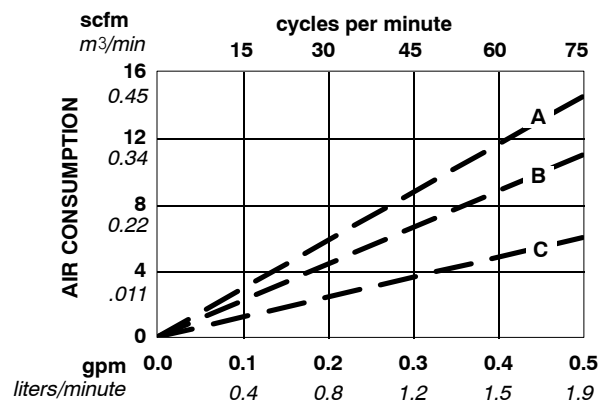

FLUID FLOW (TEST FLUID: NO. 10 WEIGHT OIL)

Technical Data

Models 239140 46:1 Ratio SST President Performance Chart

To find Fluid Outlet Pressure (psi/MPa/bar) at a specific fluid flow (lpm/gpm) and operating air pressure (psi/MPa/bar):

1. Locate desired flow along bottom of chart.
2. Follow vertical line up to intersection with selected fluid outlet pressure curve (black). Follow left to scale to read fluid outlet pressure.

To find Pump Air Consumption (m³/min or scfm) at a specific fluid flow (lpm/gpm) and air pressure (psi/MPa/bar):

1. Locate desired flow along bottom of chart.
2. Read vertical line up to intersection with selected air consumption curve (dashes). Follow left to scale to read air consumption.

- A** 100 psi (0.7 MPa, 7 bar) air pressure
- B** 70 psi (0.49 MPa, 4.9 bar) air pressure
- C** 40 psi (0.28 MPa, 2.8 bar) air pressure

President 46:1 Fluid Outlet Pressure

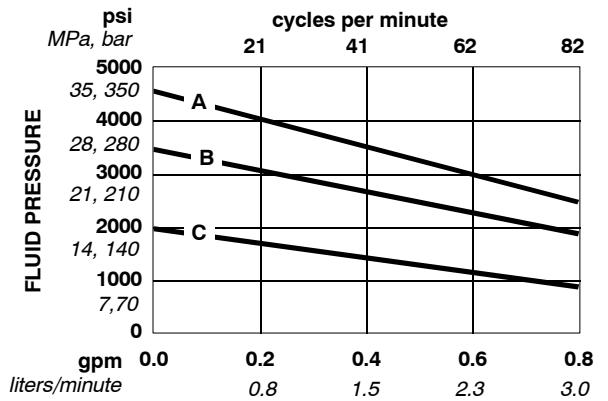

FLUID FLOW (TEST FLUID: NO. 10 WEIGHT OIL)

President 46:1 Air Consumption

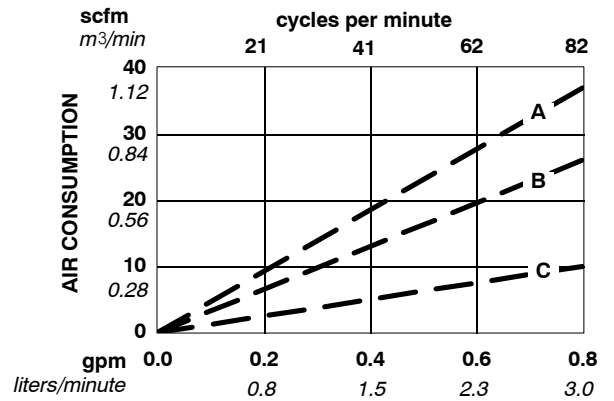

FLUID FLOW (TEST FLUID: NO. 10 WEIGHT OIL)

Graco Standard Warranty

Graco warrants all equipment manufactured by Graco and bearing its name to be free from defects in material and workmanship on the date of sale to the original purchaser for use. With the exception of any special, extended, or limited warranty published by Graco, Graco will, for a period of twelve months from the date of sale, repair or replace any part of the equipment determined by Graco to be defective. This warranty applies only when the equipment is installed, operated and maintained in accordance with Graco's written recommendations.

This warranty does not cover, and Graco shall not be liable for general wear and tear, or any malfunction, damage or wear caused by faulty installation, misapplication, abrasion, corrosion, inadequate or improper maintenance, negligence, accident, tampering, or substitution of non-Graco component parts. Nor shall Graco be liable for malfunction, damage or wear caused by the incompatibility of Graco equipment with structures, accessories, equipment or materials not supplied by Graco, or the improper design, manufacture, installation, operation or maintenance of structures, accessories, equipment or materials not supplied by Graco.

This warranty is conditioned upon the prepaid return of the equipment claimed to be defective to an authorized Graco distributor for verification of the claimed defect. If the claimed defect is verified, Graco will repair or replace free of charge any defective parts. The equipment will be returned to the original purchaser transportation prepaid. If inspection of the equipment does not disclose any defect in material or workmanship, repairs will be made at a reasonable charge, which charges may include the costs of parts, labor, and transportation.

THIS WARRANTY IS EXCLUSIVE, AND IS IN LIEU OF ANY OTHER WARRANTIES, EXPRESS OR IMPLIED, INCLUDING BUT NOT LIMITED TO WARRANTY OF MERCHANTABILITY OR WARRANTY OF FITNESS FOR A PARTICULAR PURPOSE.

Graco's sole obligation and buyer's sole remedy for any breach of warranty shall be as set forth above. The buyer agrees that no other remedy (including, but not limited to, incidental or consequential damages for lost profits, lost sales, injury to person or property, or any other incidental or consequential loss) shall be available. Any action for breach of warranty must be brought within two (2) years of the date of sale.

Graco makes no warranty, and disclaims all implied warranties of merchantability and fitness for a particular purpose in connection with accessories, equipment, materials or components sold but not manufactured by Graco. These items sold, but not manufactured by Graco (such as electric motors, switches, hose, etc.), are subject to the warranty, if any, of their manufacturer. Graco will provide purchaser with reasonable assistance in making any claim for breach of these warranties.

In no event will Graco be liable for indirect, incidental, special or consequential damages resulting from Graco supplying equipment hereunder, or the furnishing, performance, or use of any products or other goods sold hereto, whether due to a breach of contract, breach of warranty, the negligence of Graco, or otherwise.

FOR GRACO CANADA CUSTOMERS

The parties acknowledge that they have required that the present document, as well as all documents, notices and legal proceedings entered into, given or instituted pursuant hereto or relating directly or indirectly hereto, be drawn up in English. Les parties reconnaissent avoir convenu que la rédaction du présente document sera en Anglais, ainsi que tous documents, avis et procédures judiciaires exécutés, donnés ou intentés à la suite de ou en rapport, directement ou indirectement, avec les procédures concernées.

Graco Information

For the latest information about Graco products, visit www.graco.com.

TO PLACE AN ORDER, contact your Graco distributor or call to identify the distributor closest to you:

Phone: 612-623-6921 or **Toll Free:** 1-800-328-0211 **Fax:** 612-378-3505

*All written and visual data contained in this document reflects the latest product information available at the time of publication.
Graco reserves the right to make changes at any time without notice.*

Original instructions. This manual contains English. MM 307619

Graco Headquarters: Minneapolis

International Offices: Belgium, China, Japan, Korea

GRACO INC. AND SUBSIDIARIES • P.O. BOX 1441 • MINNEAPOLIS MN 55440-1441 • USA
Copyright 1983, Graco Inc. All Graco manufacturing locations are registered to ISO 9001.

www.graco.com

Revision ZAD, December 2022