

INSTRUCTIONS-PARTS LIST



307-595

Rev A

This manual contains **IMPORTANT WARNINGS** and **INSTRUCTIONS**
READ AND RETAIN FOR REFERENCE

10:1 RATIO MONARK PUMP

950 psi (66 bar) MAXIMUM WORKING PRESSURE

Part Number 217-523 Series A

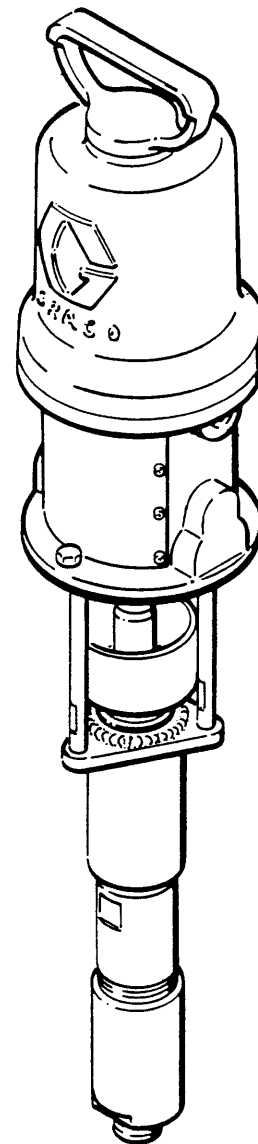

H003

GRACO INC. P.O. Box 1441 MINNEAPOLIS, MN 55440-1444

© COPYRIGHT 1982 GRACO INC.

WARNING

HIGH PRESSURE SPRAY CAN CAUSE EXTREMELY SERIOUS INJURY.

FOR PROFESSIONAL USE ONLY.

OBSERVE ALL WARNINGS.

Read and understand all instruction manuals, tags, and warnings before operating equipment.

INJECTION HAZARD

Fluids under high pressure from spray or leaks can penetrate the skin and cause extremely serious injury, including the need for amputation.

NEVER point the spray gun at anyone or any part of the body.

NEVER put hand or fingers over the spray tip.

NEVER try to stop or deflect leaks with your hand or body.

ALWAYS have tip guard in place when spraying.

MEDICAL TREATMENT

If any fluid appears to penetrate your skin get
EMERGENCY MEDICAL CARE AT ONCE:
DO NOT TREAT AS A SIMPLE CUT.

Tell the doctor exactly what fluid was injected. For treatment instructions have your doctor call the
NATIONAL POISON CENTER NETWORK
(412)681-6669

AVOID COMPONENT RUPTURE

This pump develops 950 psi (66 bar) material pressure at 95 psi (6.5 bar) air supply pressure. NEVER exceed 95 psi (6.5 bar) air supply pressure to pump.

Always be sure that all fluid handling components have a maximum working pressure rating of at least 950 psi (66 bar).

NEVER alter or modify the equipment.

Any damage to a hose can result in hose failure and possible bodily injury or property damage. Before each use, check entire hose for cuts, leaks, abrasion or bulging of cover or damage or movement of couplings. If any of these conditions exist, replace the hose immediately. Never use **tape or any device to try to mend the hose.**

Help prevent damage to hose by handling and routing carefully. Do not expose hose to temperatures above 180°F (82°C) or below -40°F (-40°C). Do not pull sprayer with hose.

USE EXTREME CARE WHEN CLEANING SPRAY TIPS AND SERVICING

Before removing any part for cleaning or servicing, always disconnect power source and carefully relieve fluid pressure by triggering spray gun, engaging gun safety latch and any other equipment safety locks, and opening any drain or bleeder valves. Leave drain valve open during servicing. Remove spray tip from gun for cleaning.

SPRAY GUN SAFETY

When spray gun is not actually spraying, always set the gun safety latch in the horizontal or "SAFE" position, making the gun inoperative.

DO NOT REMOVE OR MODIFY any part of the gun.

CHECK OPERATION OF ALL GUN SAFETY DEVICES BEFORE EACH USE.

Always remove the tip from the gun to clean it.

Be very careful when removing the spray tip or hose from gun. A plugged line contains fluid under pressure. Your system should have a drain valve downstream from the pump to relieve the pressure. If you use a fluid pressure regulator, you must install another drain valve downstream from the regulator. If tip or line is plugged, open the drain valve, **then loosen air cap retainer or hose coupling slightly** and relieve the pressure slowly before removing completely.

PREVENT STATIC SPARKING

Always be sure all system equipment and objects being sprayed are properly grounded. The high velocity flow of fluid creates static electricity. Sparks may cause fire, explosion, or electric shock.

Use only conductive or grounded air and fluid hoses for air-assisted airless applications. Be sure gun is grounded through hose connections. Check ground continuity in hose and equipment once a week. Overall (end to end) resistance of unpressurized hose must not exceed 29 megohms for any coupled length or combination of hose lengths.

Never exceed 500 ft (150 m) overall combined hose length to assure electrical continuity.

When flushing equipment, remove spray tip, use the lowest possible pressure, and maintain firm metal to metal contact between gun and grounded metal waste container. This reduces the chance of static sparking.

Follow the coating and solvent manufacturer's safety precautions and warnings.

IMPORTANT

United States Government safety standards have been adopted under the Occupational Safety and Health Act. These standards — particularly the General Standards, Part 1910, and the Construction Standards, Part 1926 — should be consulted in connection with your use of air-assisted airless spray equipment.

TYPICAL INSTALLATION

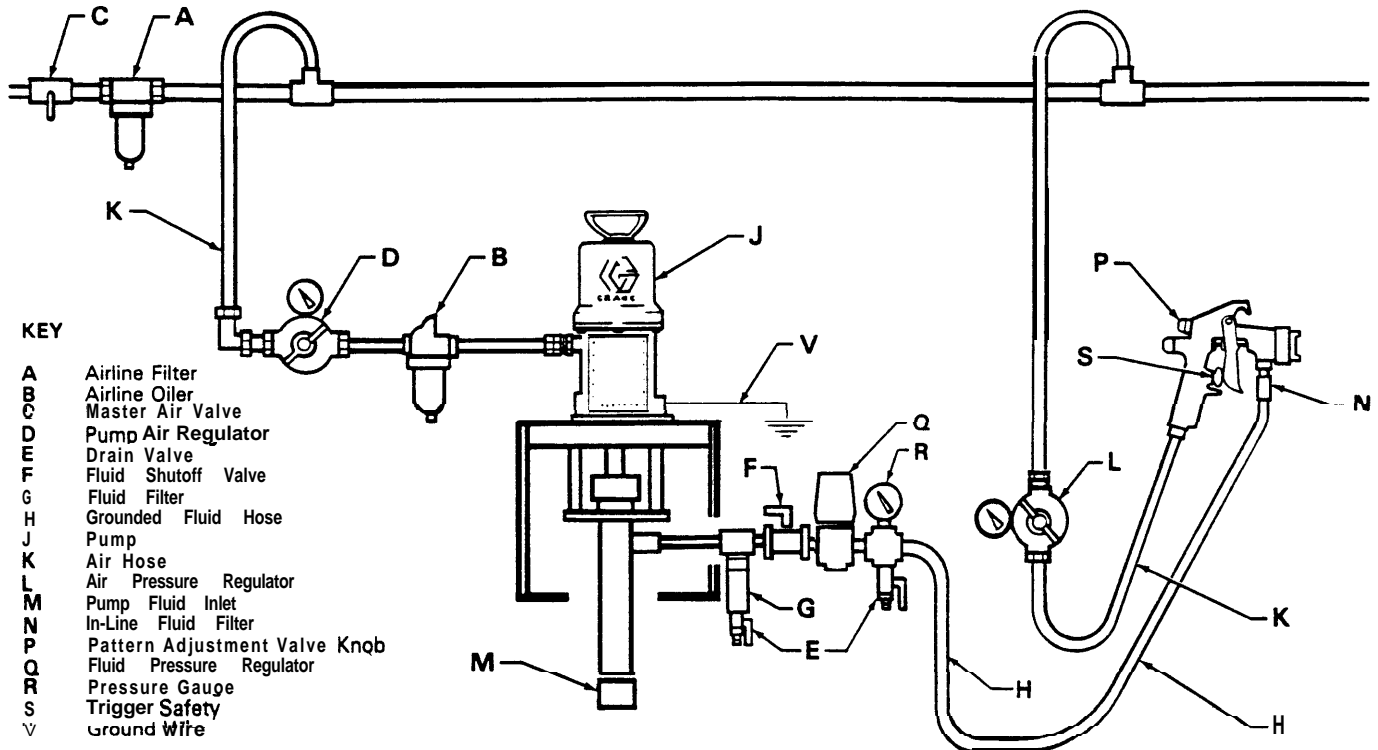

KEY

- A Airline Filter
- B Airline Oiler
- C Master Air Valve
- D Pump Air Regulator
- E Drain Valve
- F Fluid Shutoff Valve
- G Fluid Filter
- H Grounded Fluid Hose
- J Pump
- K Air Hose
- L Air Pressure Regulator
- M Pump Fluid Inlet
- N In-Line Fluid Filter
- P Pattern Adjustment Valve Knob
- Q Fluid Pressure Regulator
- R Pressure Gauge
- S Trigger Safety
- V Ground Wire

INSTALLATION

WARNING

Pressure Relief Procedure
 Always relieve the system pressure whenever you stop spraying, and before installing, removing or cleaning any parts to avoid serious bodily injury from high pressure fluid trapped in the system.

Always follow this procedure: shut off the pump, trigger the spray gun, engage the trigger safety, and slowly open the drain valve(s). Leave the drain valve(s) open until you are ready to use the system again.

WARNING

The gun must be grounded through the fluid hose to prevent generation of static electricity, which can cause static sparking, electric shock and possible fire or explosion.

The dimensional drawing on the back page gives measurements needed for installing pump on a custom designed mounting. See ACCESSORIES on back page for available Graco mounting accessories.

NOTE: Reference numbers and letters in parentheses in the text refer to the Typical Installation, Fig 1, 2, and Parts Drawing.

Connect a ground wire to pump air motor. Loosen grounding lug locknut (T) and washer (U). Insert one end of a 12 ga (1.5 mm²) minimum ground wire (V) into slot in lug (W) and tighten locknut securely. See Fig 1.

Connect the other end of wire to a good ground. Check your local code. See ACCESSORIES for available ground wire and clamp.

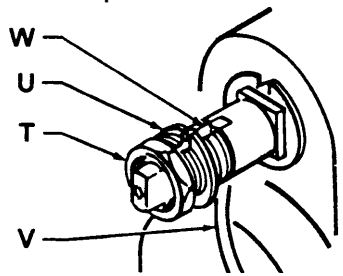

Fig 1

System Accessories

Refer to the Typical Installation drawing and the ACCESSORIES section for assistance in setting up your system. If you supply your own accessories, be sure they are adequately sized to meet your system requirements.

We recommend installing an air line filter (A) to remove harmful dirt and moisture from your compressed air supply, an air line oiler (B) for automatic pump lubrication, a bleed-type master air valve (C), and an air regulator (D) to control pump speed and material pressure. See Accessories on back page.

Downstream from the pump in the fluid line, we recommend installing a fluid shutoff valve (F), a fluid filter (G), a drain valve (E), and a fluid pressure regulator (Q).

Air and fluid valves are used to shut off and/or relieve pressures in the system before adding, removing or servicing any parts of the system.

Connect Hoses

Connect a grounded air line hose (K), a grounded fluid hose (H) and a suction hose to your system.

Connect a suction hose or siphon tube to the 3/4 npt(m) intake (M) of pump.

Connect a 1/2 in. ID (minimum) grounded air supply hose (K) to the pump's 1/2 npt(f) air inlet or the air regulator's inlet fitting.

OPERATION

Flush the Pump Before Using

Pumps are tested with No. 10 motor oil which is left in to protect pump parts. To prevent contamination of material, flush pump with a compatible solvent before using. If pump is being used to supply a circulating system, allow solvent to circulate for at least 10 minutes.

Starting and Adjusting Pump

Fill wet-cup (19) one half full with Graco Throat Seal Liquid (TSL), trigger spray gun and slowly open air supply valve until pump starts (about 20 psi (1.4 bar)). Allow pump to cycle slowly until all air is pushed out of lines. Release trigger, pump will stall against pressure.

With pump and lines primed, and with adequate air pressure and volume supplied, the pump will start and stop as the spray gun is triggered and released. In a circulating system, it will run continuously and speed up or slow down as supply demands until air supply is shut off.

Use an adequately sized air regulator to control pump speed and material pressure. See ACCESSORIES. Always use the lowest air pressure necessary to give you the results you want.

Never exceed 95 psi (6.5 bar) air pressure to pump.

Keep the wet-cup (19) filled with Graco Throat Seal Liquid (TSL). See Fig 2.

Never allow the pump to run dry of material being pumped. A dry pump will quickly accelerate to a high speed, possibly damaging itself. If your pump accelerates quickly, or is running too fast, stop it immediately and check the material supply. If the supply container is empty and air has been pumped into lines, prime pump and lines with material, or flush and leave filled with compatible solvent. Be sure to eliminate all air from fluid system.

Shutdown and Care of Pump

For overnight shutdown, shut off and relieve air pressure and material pressure according to the *Pressure Relief Procedure* warning on page 3. Always stop the pump at the bottom of its stroke to keep material from drying on the exposed displacement rod and damaging throat packings.

Always flush the pump before the material dries on rod. If the pump is to be stored for any period of time, and you are pumping water based material, first flush with water, then with mineral spirits to protect the pump parts from rusting.

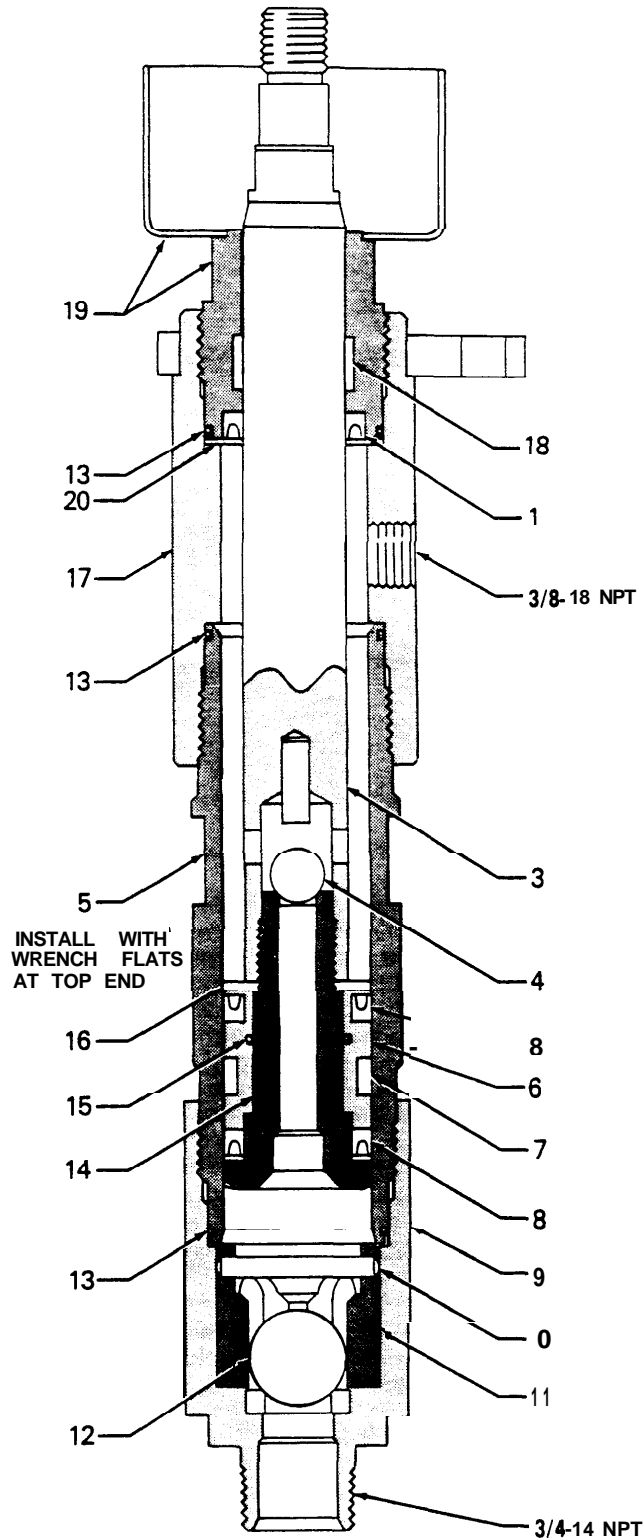

KEY

1 Throat Packing	11 Ball Guide
3 Displacement Rod	12 Ball
4 Ball	13 Packing
5 Cylinder	14 Piston Valve
6 Spacer	15 Packing
7 Bearing	16 Washer
8 Piston Packing	17 Housing
8 Intake Valve Housing	18 Bearing
10 Ball Stop Pin	19 Nut (Wet-Cup)
	20 Washer

Fig 2

WARNING

TO AVOID SERIOUS BODILY INJURY: Always disconnect air supply and relieve all pressures before servicing pump. Never operate pump with air muffler plates removed. They contain important warnings and also protect you from the moving air piston.

TROUBLESHOOTING CHART

Problem	Cause	Solution
Pump fails to operate.	Restricted line or inadequate air supply. Insufficient air pressure. Closed or clogged air valves, etc. Exhausted material supply. Damaged air motor. Dried material seizure of displacement rod (3).	Clear line or increase line size. Open air valves, clean if necessary. Refill. Service. See 307-043. Remove.
Pump operates but output low on both strokes.	Restricted line or inadequate air line supply. Insufficient air pressure. Closed or clogged air valves, etc. Exhausted material supply. Obstruction material line, valves, etc. Worn packings (8 & 13).	Clear line or increase line size. Open air valves, clean if necessary. Refill. Clear*. Replace packings.
Pump operates but output low on downstroke.	Held open or worn fluid intake valve.	Clear, service.
Pump operates but output low on upstroke.	Held open or worn fluid piston valve or packing leaking.	Clear, service.
Erratic or accelerated operation.	Exhausted material supply.	Refill.
	Held open or worn fluid intake valve.	Clear, service.
	Held open or worn piston valve or packing leaking.	Clear, service.

*Release pressures and disconnect material line. Reduce the air pressure to 20 psi (1.4 bar). If pump starts when air is turned on again, the line, etc. is clogged.

Check all other remedies before disassembling pump.

WARNING

Pressure Relief Procedure

Always relieve the system pressure whenever you stop spraying, and before installing, removing or cleaning any parts to avoid serious bodily injury from high pressure fluid trapped in the system.

Always follow this procedure: shut off the pump, trigger the spray gun, engage the trigger safety, and slowly open the drain valve(s). Leave the drain valve(s) open until you are ready to use the system again.

Solvent flush material from pump, and follow *Pressure Relief Procedure* warning above.

NOTE: If you are using a repair kit to service the pump, use all the new parts, even if the old ones look good. The old parts will wear faster, making pump service needed again sooner. Repair Kit No. 217531 is available.

Always check the inside of cylinder (5) and outside of displacement rod (3) carefully for nicks, scratches and scoring which could cause leaking and premature wear of packings.

Intake Valve

Screw the intake valve housing (9) off of the cylinder (5). If the valve is seized on the cylinder, apply penetrating oil around the threads and gently tap around the cylinder with a plastic hammer to loosen. See Fig 2.

Take out the ball guide (11), pin (10) and ball (12). See Fig 2. Clean all parts and inspect them carefully for wear or damage. Lubricate the outside of the packing (13) with grease compatible to the material being pumped. Reassemble the valve using new parts as necessary and screw it back onto the pump cylinder.

Piston, Cylinder and Displacement Rod

Remove the tie rod locknuts (105). See the Complete Pump parts drawing. Pull the displacement pump (113) away from the air motor (103). Remove the cotter pin (106) and unscrew the pump displacement rod from the air motor connecting rod.

Unscrew the cylinder (5) from the pump housing (17). See Fig 2. Inspect for wear or damage. Replace the o-rings (13). Lubricate the outside of the packing (13) with grease compatible to the material being pumped.

Push the displacement rod down out of the pump housing. Secure the rod in a vise and unscrew the piston (there is Loctite on the threads). Remove the ball (4), washer (16), u-cup packings (8), spacer (6) and bearing (7).

Clean all parts and inspect carefully for wear or damage. Check the rod carefully for nicks, scratches or wear. Use new parts where needed and reassemble. Apply Loctite No. 242 to the piston threads. Lubricate the outside of the packings with grease compatible to the material being pumped before putting the spacer on the piston. Torque the piston to 15-20 ft-lb (20.3-27.0 N·m).

NOTE: Notice the difference between the 2 piston packings (8) and the throat packing (1). See Fig 3. Be sure to install the packings as shown.

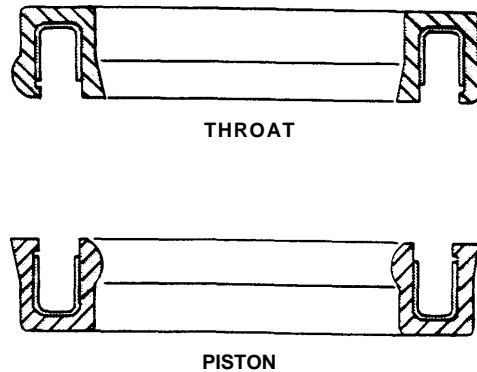

Fig 3

Throat Packing

Unscrew the packing nut (19) from the pump housing (17). Remove the u-cup packing (1) and bearing (18). Clean and inspect the parts. Install a new bearing (18), packing (1) and o-ring (13).

To install the new bearing (18), roll it up tight and insert into the packing nut so it snaps into the groove. See Fig 4.

Reassemble the pump in reverse order of disassembly. Lubricate the packings with grease compatible to the material being pumped. Assemble connecting rod to air motor and screw locknuts loosely onto tie rods. Use Loctite No. 242 on the connecting rod threads. Tighten the packing nut just snug. Finish tightening locknuts evenly to 35-50 ft-lb (47-68 N·m). Start pump and run at a slow speed to check tie rods for signs of binding. Adjust if necessary.

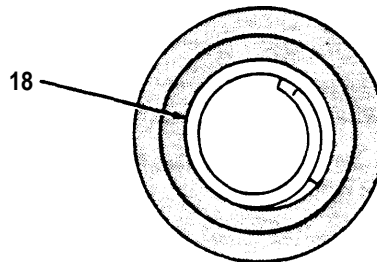
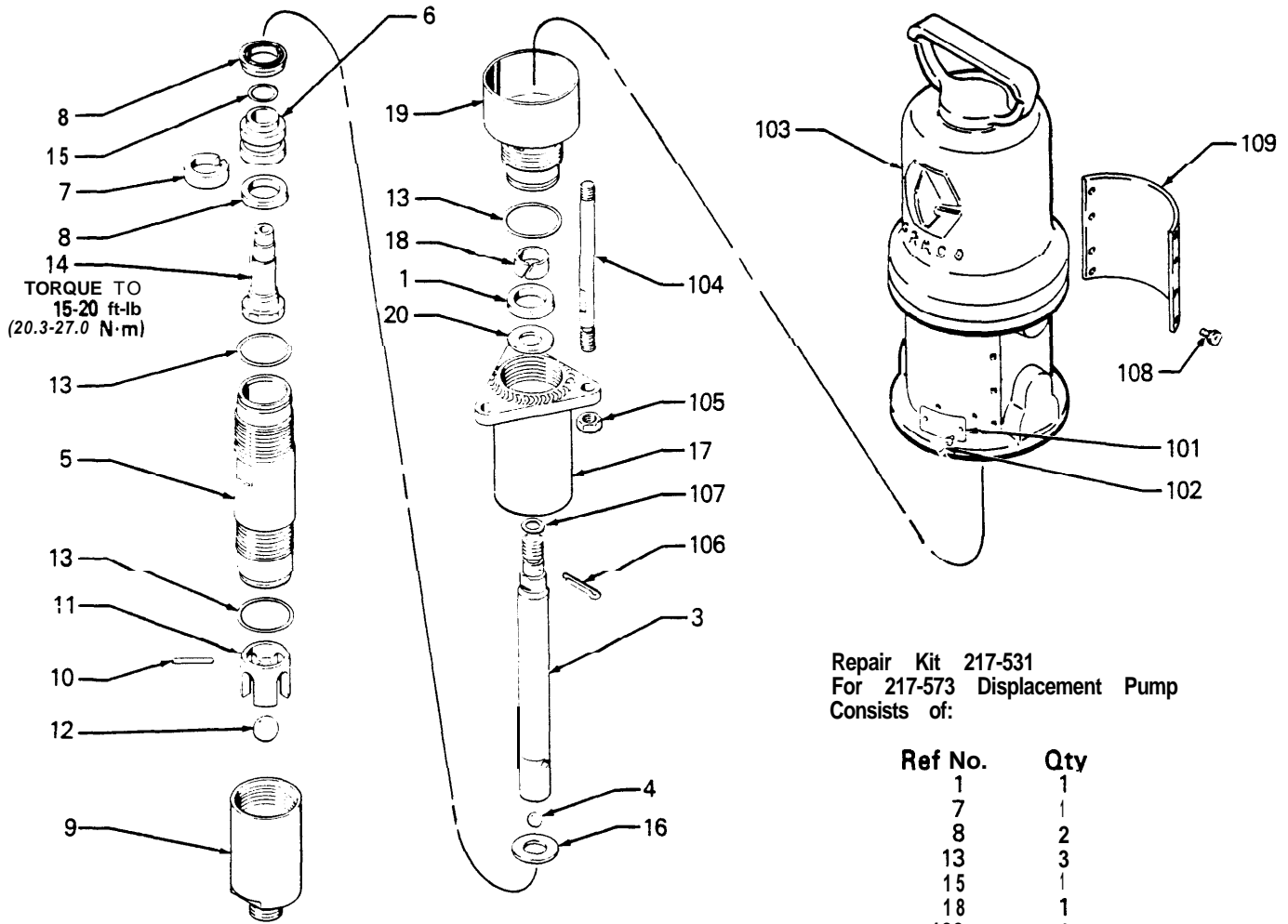

Fig 4

PARTS DRAWING



Repair Kit 217-531
For 217-573 Displacement Pump
Consists of:

Ref No.	Qty
1	1
7	1
8	2
13	3
15	1
18	1
106	1
107	1

PARTS LIST

for 217-573 Displacement Pump

REF NO.	PART NO.	DESCRIPTION
1	178-913	SEAL, U-cup, UHMW polyethylene
3	218-054	ROD, displacement
4	101-874	BALL, bearing, stainless steel, 0.5" dia
5	178-889	CYLINDER
6	178884	FIXER
7	178881	BEARING, piston, Delrin
8	178-912	SEAL, piston, U-cup, UHMW polyethylene
9	217-521	VALVE, foot
10	178-887	PIN, ball stop
11		GUIDE, ball
12	178-883 101-917	BALL, bearing, 0.875"
14	107-078	PACKING, o-ring, PTFE
15	217-520	VALVE, piston stud
16	107-079	PACKING, o-ring, PTFE
17	217-522 178-911	WASHER
18		HOUSING, pump
19	217-519 178-885	BEARING, Delrin
		NUT, bearing, with wet-cup
20	178-963	WASHER

for 217-523 Series A Complete Pump

REF NO.	PART NO.	DESCRIPTION	QTY
101	172-448	PLATE, designation	1
102	104-088	RIVET, blind	2
103	215-383	MOTOR, air, Monark, see 307-043 for parts	1
104	164-722	ROD, tie	3
105	101-566	LOCKNUT	3
106	101-946	PIN, cotter, 1/8 dia x 1.5" lg	1
107	101-946	PACKING, o-ring, nitrile rubber	1
108	100-078	SCREW, pan hd thd forming, 8-32 x 0.375"	8
109	172-443	PLATE, instruction	1
113	217-573	DISPLACEMENT PUMP, see separate list for parts	1

* Supplied in repair kit 217-53 1.

Order parts by name and series letter of the assembly for which you are ordering.

ACCESSORIES (Must be purchased separately)

PTFE PACKING CONVERSION KIT 217-553

For temperatures above 140°F (60°C).

Consists of:

- 178-918 (2) Piston Packings
- 178-919 (1) Throat Seal

AIR PRESSURE REGULATOR and GAUGE 206-237

300 psi (21 bar) MAXIMUM WORKING PRESSURE

- 1/2 NPT INLET
- 3/8 NPT OUTLET

GROUNDING CLAMP 103-538

GROUND WIRE 208-950

25 ft (7.6 m) lg., 12 ga.

AIR SUPPLY HOSE

175 psi (12 bar) MAXIMUM WORKING PRESSURE

1/2 in. ID, 1/2 npt(m) couplings, Buna-N

- 205-418 6 f-t (1.8 m)
- 205-216 15 ft (4.6 m)
- 205-273 25 ft (7.6 m)
- 208-594 50 ft (15.2 m)

BLEED TYPE MASTER AIR VALVE 100-473

300 psi (21 bar) MAXIMUM WORKING PRESSURE

1/2 npt(fbe)

FLUID PRESSURE REGULATOR 217-676

1000 psi (70 bar) MAXIMUM WORKING PRESSURE

AIR LINE FILTER

250 psi (17.5 bar) MAXIMUM WORKING PRESSURE

- 106-148 3/8 npt(f)
- 106-149 1/2 npt(f)

AIR LINE OILER

250 psi (17.5 bar) MAXIMUM WORKING PRESSURE

- 214-847 3/8 npt(f)
- 214-848 1/2 npt(f)

GRACO THROAT SEAL LIQUID

Non-evaporating solvent for wet-cup

- 206-995 1 quart (0.95 liter)
- 266996 1 gallon (3.8 liter)

55 GAL. (200 liter) SUCTION KIT 208-259

REF PART NO. DESCRIPTION QTY

- 1 156-591 ELBOW, 90°; 3/4 npt; I-I 1/2-24 uns thd
- 2 156-593 PACKING, o-ring
- 3 156-592 TUBE, riser
- 4 176-684 ADAPTER, bung
- 5 100-200 THUMBSCREW
- 6 159-100 RETAINER, screen
- 7 161-377 SCREEN, filter
- 8 159-101 NUT, screen retainer
- 9 214-961 HOSE, cpfd 3/4 npt(mbe) 6 ft (1.8 m) long
- 10 156-589 UNION, 90°; 3/4 npt x 3/4 npsm

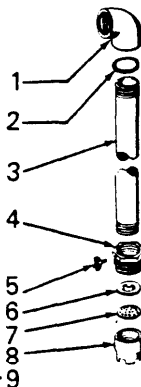

Wetted Parts : Zinc plated steel, aluminum, rubber, Nylon.

MOUNTING HOLE LAYOUT

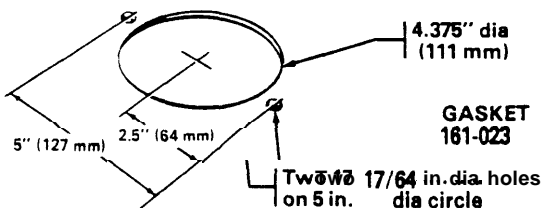

DIMENSIONAL DRAWING

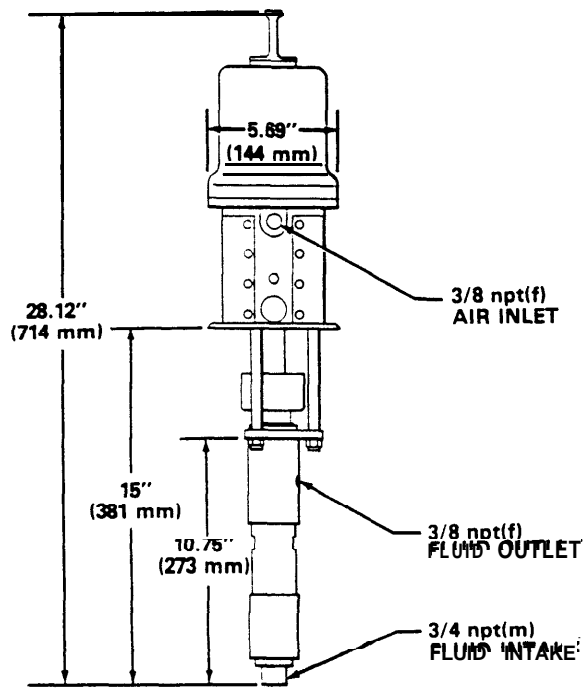

TECHNICAL DATA

Air operating range	20-95 psi (1.5-6.3 bar)
Maximum air consumption	Approximately 15 SCFM per gallon pumped at 95 psi
Maximum recommended pump speed	60 cycles/min; 1 gpm
Recommended speed for optimum pump life	15-25 0.25-0.4 gpm
Maximum working pressure	950 psi (66 bar)
Wetted parts	Zinc plated, carbon steel, stainless steel, PTFE, UHMW polyethylene, Delrin
Weight	23 lb (10.4 kg)

THE GRACO WARRANTY

Graco Inc. warrants all equipment manufactured by it and bearing its name to be free from defects in material and workmanship under normal use and service. This warranty extends to the original purchaser for a period of 12 months from the date of purchase and applies only when the equipment is installed and operated in accordance with written factory recommendations. This warranty does not cover damage or wear which, in the reasonable judgment of Graco, arises from misuse, abrasion, corrosion, negligence, accident, substitution of non-Graco parts, faulty installation or tampering.

This warranty is conditioned upon the prepaid return of the equipment claimed to be defective for examination by Graco to verify the claimed defect. If the claimed defect is verified, Graco will repair or replace free of charge, any defective parts. The equipment will be returned to the original purchaser transportation prepaid. If inspection of the equipment does not disclose any defect in workmanship or material, repairs will be made at a reasonable charge and return transportation will be charged.

THIS LIMITED WARRANTY IS EXCLUSIVE, AND IS IN LIEU OF ANY OTHER WARRANTIES (EXPRESS OR IMPLIED) INCLUDING WARRANTY OF MERCHANTABILITY OR WARRANTY OF FITNESS FOR A PARTICULAR PURPOSE AND OF ANY NON-CONTRACTUAL LIABILITIES INCLUDING PRODUCT LIABILITIES BASED ON NEGLIGENCE OR STRICT LIABILITY. EVERY FORM OF LIABILITY FOR DIRECT, SPECIAL OR CONSEQUENTIAL DAMAGES OR LOSS IS EXPRESSLY EXCLUDED AND DENIED.

EQUIPMENT NOT COVERED BY GRACO WARRANTY. Accessories or components of equipment sold by Graco that are not manufactured by Graco (such as electric motors, switches, hose, etc.) are subject to the warranty, if any, of their manufacturer. Graco will provide purchaser with reasonable assistance in making such claims.

Factory Branches: Atlanta, Dallas, Detroit, Los Angeles, West Caldwell (N.J.)
 Subsidiary and Affiliate Companies: Canada; England; Switzerland; France; Germany; Hong Kong; Japan

GRACO INC. P. O. Box 1441 MINNEAPOLIS, MN 55440-1444

PRINTED IN U.S.A. 307-595 11-82