

# 5:1 Ratio Monark<sup>®</sup> Sanitary Pump

307056U

## Divorced Design

600 psi (4.1 MPa, 41 bar) Maximum Fluid Working Pressure

120 psi (0.8 MPa, 8 bar) Maximum Air Inlet Pressure



### Important Safety Instructions

Read all warnings and instructions in this manual.  
Save these instructions.

See **List of Models** on page 2.

## Contents

Symbols .....	2
Safety Warnings .....	3
Installation .....	4
Operation .....	7
Maintenance .....	8
Troubleshooting .....	9
Service .....	10
Parts .....	14
Dimensions .....	18
Technical Data .....	19
Warranty .....	20
Graco Information .....	20

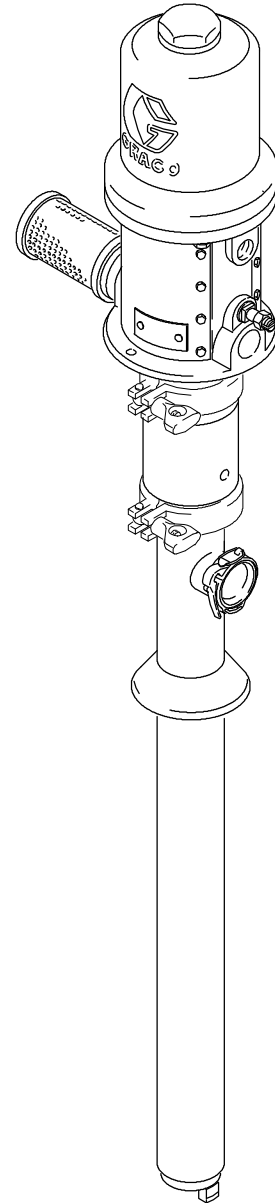

# List of Models

Part No. (Series)	Pump Type	Pump Size	Ratio	Maximum Fluid Working Pressure	Maximum Pump Air Input Pressure
207550 (E)	Double Ball	55 gal. (200 liter) Drum	5:1	600 psi (4.1 MPa, 41 bar)	120 psi (0.8 MPa, 8 bar)
903035 (A)	Double Ball	55 gal. (200 liter) Drum	5:1	600 psi (4.1 MPa, 41 bar)	120 psi (0.8 MPa, 8 bar)
954383 (A)	Double Ball	Stubby	5:1	600 psi (4.1 MPa, 41 bar)	120 psi (0.8 MPa, 8 bar)
965520 (A)	Double Ball	Stubby	5:1	600 psi (4.1 MPa, 41 bar)	120 psi (0.8 MPa, 8 bar)
952793 (A)	Priming Piston	Stubby	5:1	600 psi (4.1 MPa, 41 bar)	120 psi (0.8 MPa, 8 bar)

## Symbols

### Warning Symbol



This symbol alerts you to the possibility of serious injury or death if you do not follow the instructions.

### Caution Symbol



This symbol alerts you to the possibility of damage to or destruction of equipment if you do not follow the instructions.

## ! WARNING



### FIRE AND EXPLOSION HAZARD

Improper grounding, poor ventilation, open flames or sparks can cause a hazardous condition and result in a fire or explosion and serious injury.

- Ground the equipment. Refer to **Grounding** on page 4.
- If there is any static sparking or you feel an electric shock while using this equipment, **stop dispensing immediately**. Do not use the equipment until you identify and correct the problem.
- Provide fresh air ventilation to avoid the buildup of flammable fumes from solvents or the fluid being dispensed.
- Keep the dispense area free of debris, including solvent, rags, and gasoline.
- Electrically disconnect all equipment in the dispense area.
- Extinguish all open flames or pilot lights in the dispense area.
- Do not smoke in the dispense area.
- Do not turn on or off any light switch in the dispense area while operating or if fumes are present.
- Do not operate a gasoline engine in the dispense area.
- Keep a fire extinguisher in the work area.

# WARNING



INSTRUCTIONS

## EQUIPMENT MISUSE HAZARD

Equipment misuse can cause the equipment to rupture or malfunction and result in serious injury.

- This equipment is for professional use only.
- Read all instruction manuals, tags, and labels before operating the equipment.
- Use the equipment only for its intended purpose. If you are not sure, call your Graco distributor.
- Do not alter or modify this equipment.
- Check equipment daily. Repair or replace worn or damaged parts immediately.
- Do not exceed the maximum working pressure of the lowest rated system component. Refer to the **Technical Data** on page 19 for the maximum working pressure of this equipment.
- Use fluids and solvents which are compatible with the equipment wetted parts. Refer to the **Technical Data** section of all equipment manuals. Read the fluid and solvent manufacturer's warnings.
- Do not kink or overbend hoses or use hoses to pull equipment.
- Route hoses away from traffic areas, sharp edges, moving parts, and hot surfaces. Do not expose Graco hoses to temperatures above 180°F (82°C) or below -40°F (-40°C).
- Wear hearing protection when operating this equipment.
- Do not lift pressurized equipment.
- Comply with all applicable local, state, and national fire, electrical, and safety regulations.



## TOXIC FLUID HAZARD

Hazardous fluid or toxic fumes can cause serious injury or death if splashed in the eyes or on the skin, inhaled, or swallowed.

- Know the specific hazards of the fluid you are using.
- Store hazardous fluid in an approved container. Dispose of hazardous fluid according to all local, state and national guidelines.
- Always wear protective eyewear, gloves, clothing and respirator as recommended by the fluid and solvent manufacturer.



## MOVING PARTS HAZARD

Moving parts, such as the air motor piston and the priming piston (used on Part No. 952793 Pump), can pinch or amputate your fingers.

- Keep clear of all moving parts when starting or operating the pump.
- Keep hands and fingers away from the priming piston during operation and whenever the pump is charged with air.
- Before servicing the equipment, follow the **Pressure Relief Procedure** on page 7 to prevent the equipment from starting unexpectedly.

# Installation

## Grounding

**⚠ WARNING**

**FIRE AND EXPLOSION HAZARD**  
Before operating the pump, ground the system as explained below. Also read the section **FIRE AND EXPLOSION HAZARD** on page 2.

1. *Pump*: use a ground wire and clamp. See Fig. 1. Loosen the grounding lug locknut (W) and washer (X). Insert one end of the ground wire (Y) into the slot in lug (Z) and tighten the locknut securely. Connect the other end of the wire to a true earth ground.

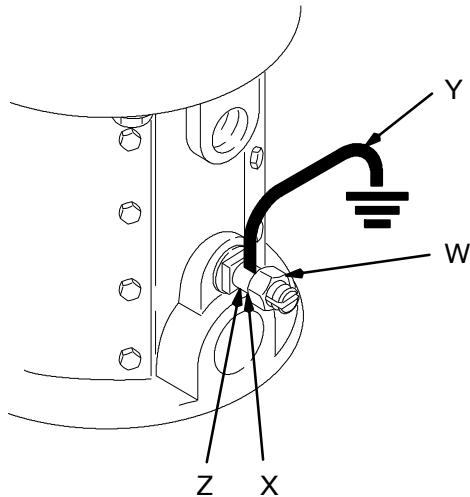

**Fig. 1**

2. *Air and fluid hoses*: use only electrically conductive hoses.

3. *Air compressor*: follow manufacturer's recommendations.
4. *Dispense valve*: ground through connection to a properly grounded fluid hose and pump.
5. *Fluid supply container*: follow your local code.
6. *Container being dispensed into*: follow your local code.
7. *Solvent pails used when flushing*: follow your local code. Use only metal pails, which are conductive, placed on a grounded surface. Do not place the pail on a nonconductive surface, such as paper or cardboard, which interrupts the grounding continuity.
8. *To maintain grounding continuity when flushing or relieving pressure*, hold a metal part of the dispense valve firmly to the side of a grounded metal pail, then trigger the valve.

## General Information

**NOTE:** Reference numbers and letters in parentheses in the text refer to the callouts in the figures and the parts drawing.

**NOTE:** Always use Genuine Graco Parts and Accessories, available from your Graco distributor. Refer to the Product Data Sheet for the pump, Form No. 304410. If you supply your own accessories, be sure they are adequately sized and pressure rated for your system.

Fig. 2 is only a guide for selecting and installing system components and accessories. Contact your Graco distributor for assistance in designing a system to suit your particular needs.

# Installation

## Mounting the Pump

Mount the pump to suit the type of installation planned. The pump dimensions are shown on page 18.

When mounting the pump in a 2 in. bung type drum, use the accessory bung adapter 205573. Remove the intake valve as explained on page 10, slide the bung adapter onto the cylinder, and replace the intake valve. Screw the bung adapter tightly into the drum bung hole and tighten the thumbscrew to hold the pump about 0.5" (13 mm) off the bottom of the drum. Loosen the drum vent plug to prevent a vacuum from forming.

When mounting the pump in an open container, use the accessory pump clamp 204858 and bung adapter 205573.

Screw the air exhaust muffler (A) into the 3/4 npt(f) outlet (B) in the motor base.

### WARNING

To avoid contaminating the fluid with lubricants, air line scale, rust, etc., pipe the exhaust air outside of the fluid product area. Vent the exhaust to a safe place, away from people, animals or food handling areas.

## System Accessories

Install a bleed-type master air valve (D) close to the pump air inlet (F), to relieve air trapped between it and the air motor.

### WARNING

The bleed-type master air valve (D) is required in your system to shut off and relieve air pressure that may be trapped in the air motor. This air could cause the pump to cycle unexpectedly, which could result in serious injury, including amputation or splashing of fluid in the eyes or on the skin.

Install an air filter/regulator (C) in the pump air line, *upstream from the bleed valve*, to control air inlet pressure and to remove harmful dirt and contaminants from your compressed air supply.

Install another bleed-type master air valve (D) upstream from all air line accessories and use it to isolate the accessories during cleaning and repair.

On the air drop to the dispensing valve (J), install an air regulator (L) to control air pressure to the valve. Install a bleed valve (D) to use as a shutoff when servicing the dispensing valve.

Connect air solenoid valves (E) to a timer control (K), and set so the dispensing valve (J) will dispense at proper intervals.

## Connect the Hoses

Connect electrically conductive air supply hoses to the air inlets of the pump and dispensing valve.

Connect the fluid line between the pump's 1-1/2" flanged fluid outlet and the fluid inlet of the dispensing valve.

**NOTE: *Be sure*** to install the complete system in accordance with all state sanitary standard codes and local regulations.

# Installation

## KEY

- |  |  |  |
|--|--|--|
| <b>A</b> Air Exhaust Muffler (may alternately be mounted remotely, using exhaust hose) | <b>F</b> 3/8 npt Air Inlet                     | <b>M</b> Bung-Mounted Sanitary Pump  |
| <b>B</b> 3/4 npt Exhaust Air Outlet  | <b>G</b> Air Line Drain Pipe and Valve         | <b>N</b> Dispensing Valve Air Exhaust Hose                                     |
| <b>C</b> Air Line Filter/Regulator   | <b>H</b> 1-1/2" Tube Size Flanged Fluid Outlet | <b>P</b> Sensing Device  |
| <b>D</b> Bleed-Type Master Air Valve (required)  | <b>J</b> Dispensing Valve                      | <b>Y</b> Pump Ground Wire (required; see page 4 for installation instructions) |
| <b>E</b> Air Solenoid Valve  | <b>L</b> Air Regulator                         |  |

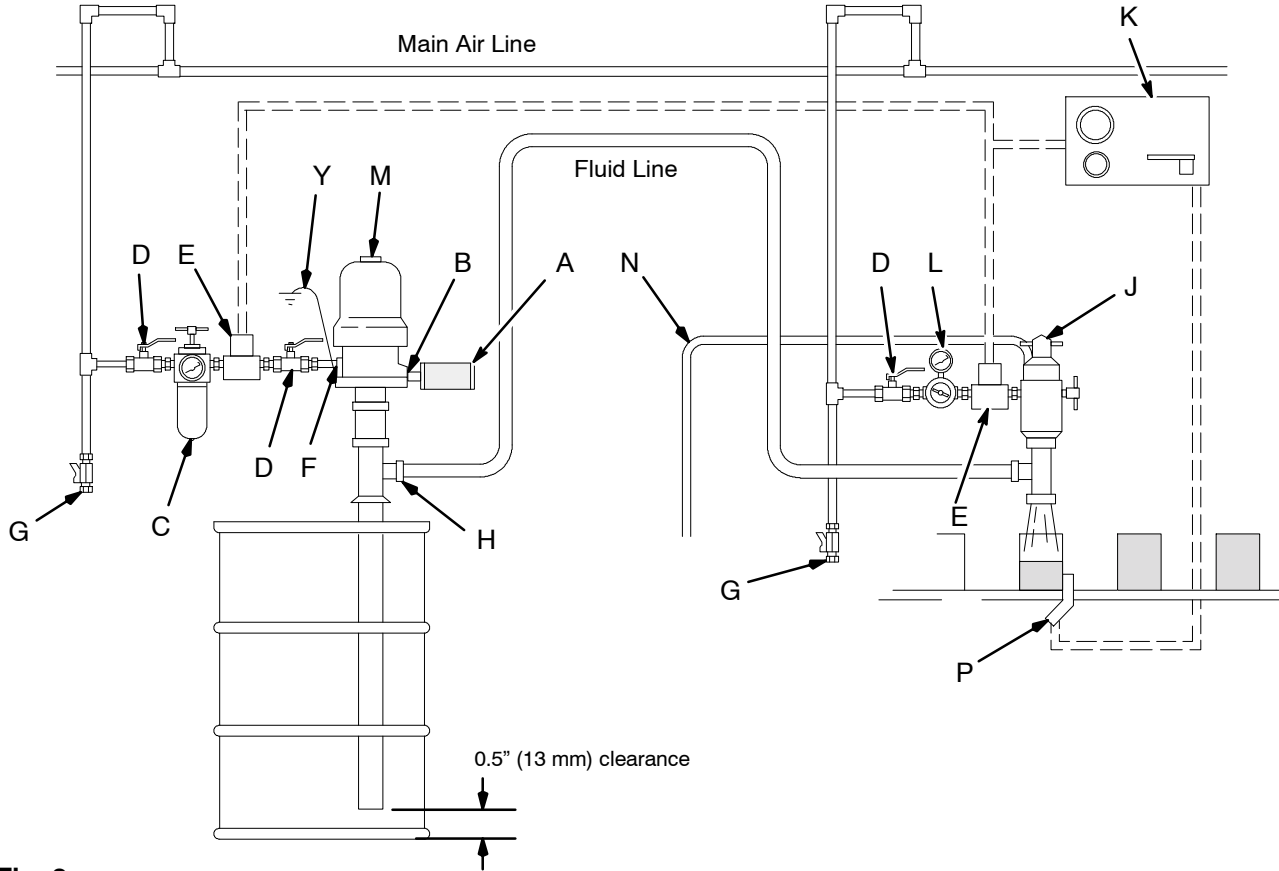

Fig. 2

0591

# Operation

## Pressure Relief Procedure

### WARNING

#### PRESSURIZED EQUIPMENT HAZARD

The system pressure must be manually relieved to prevent the system from starting or spraying accidentally. To reduce the risk of an injury from accidental spray from the dispense valve, splashing fluid, or moving parts, follow the **Pressure Relief Procedure** whenever you:

- are instructed to relieve the pressure,
- stop dispensing,
- check or service any of the system equipment,
- or install or clean the dispense valve nozzle.

1. Shut off the air supply to the pump.
2. Close the bleed-type master air valve (required in system).
3. Open the fluid ball valve and/or dispensing valve to relieve fluid pressure.

**NOTE:** The sanitary pump was assembled using sanitary lubricant on moving parts and was tested in water. Flush the pump thoroughly with an approved cleaning solution or disassemble and sanitize the parts before using the pump. Refer to the **Cleaning Procedure** on page 8. Check local and state codes for specific limitations.

## Adjusting the Pump Speed and Pressure

### WARNING

#### COMPONENT RUPTURE HAZARD



To reduce the risk of component rupture, which could cause serious injury, **never** exceed 120 psi (8 bar) air supply pressure to the pump. Read the warning section **EQUIPMENT MISUSE HAZARD**.

Open the bleed-type master air valve (D). Adjust the pump air regulator (C) until the pump is running smoothly.

Allow the pump to cycle slowly until all air is pushed out of the lines (the fluid will be flowing in a steady stream from the fluid outlet) and the pump is primed.

With the air supply turned on, the pump will start when the dispensing valve is opened, and stall against pressure when the valve is closed. In a circulating system, the pump operates until the air supply is turned off.

## Pump Shutdown

### WARNING

To reduce the risk of serious injury whenever you are instructed to relieve pressure, always follow the **Pressure Relief Procedure** at left.

To shut off the pump, **relieve the pressure**.

## Care of the Pump

### CAUTION

**Do not** expose the air motor to temperatures higher than 200°F (93°C) or the immersed fluid pump to temperatures higher than 250°F (121°C). Excessive temperatures may damage the pump packings and seals.

If the pump accelerates quickly, or is running too fast, stop the pump immediately and check the fluid supply. If the supply is empty and air has been pumped into the lines, refill the container and prime the pump and lines with fluid. Be sure to eliminate all air from the system.

### CAUTION

**Never** allow the pump to run dry of fluid. A dry pump will accelerate to a high speed, possibly damaging itself.

Always stop the pump at the bottom of its stroke to prevent fluid from drying on the displacement rod (the air motor will exhaust at the bottom of the stroke).

# Maintenance

## **IMPORTANT NOTE:**

The following instructions show a basic procedure for cleaning a sanitary system. However, **be sure** to clean the pump and system in accordance with your state sanitary standard codes and local regulations.

**Be sure** to disassemble the pump in order to thoroughly clean it.

## **Cleaning Procedure**

1. Remove the pump from the fluid container and operate it until as much of the fluid as possible has been pumped out.
2. Flush the system thoroughly with an approved cleaning solution.

### **WARNING**

To reduce the risk of serious injury whenever you are instructed to relieve pressure, always follow the **Pressure Relief Procedure** on page 7.

3. **Relieve the pressure.** Remove the air and fluid hoses from the pump. Disassemble the fluid pump and accessories. See **Service** to disassemble the pump.

4. Wash all the pump parts with an alkaline detergent at the manufacturer's recommended temperature and concentration, using either a brush or other C.O.P. methods.
5. Rinse all the pump parts again with water and allow them to dry.
6. Inspect all the pump parts and reclean any parts that are still soiled.

### **WARNING**

Any damaged rubber parts **must** be replaced as they will harbor microorganisms that can contaminate the fluid.

7. Immerse all pump parts and the lubricant tube in an approved sanitizer before assembly. Take the pump parts out of the sanitizer one-by-one as needed.
8. Lubricate the moving pump parts and o-rings, packings and seals with approved waterproof sanitary lubricant.
9. Circulate the sanitizing solution through the pump and the system prior to use.



# Troubleshooting

## WARNING

To reduce the risk of serious injury whenever you are instructed to relieve pressure, always follow the **Pressure Relief Procedure** on page 7.

1. **Relieve the pressure.**
2. Check all possible remedies in the Troubleshooting Chart before disassembling the pump.

Problem	Cause	Solution
Pump fails to operate	Restricted air line or inadequate air supply Insufficient air pressure; closed or clogged air valves, etc. Exhausted fluid supply Damaged air motor	Clear air line or increase air supply.  Open or clean air valves, etc.  Refill fluid supply. Service, see manual 307043.
Pump operates but output low on both strokes	Restricted air line or inadequate air supply Insufficient air pressure; closed or clogged air valves, etc. Exhausted fluid supply Obstructed fluid line, valves, dispensing valve, etc.  Worn throat packing (8) Damaged cylinder o-rings (13)	Clear air line or increase air supply.  Open or clean air valves, etc.  Refill fluid supply. Clear. (Relieve pressures and disconnect fluid line. Turn on air; if pump starts, the line, etc. is clogged.) Replace throat packing. Replace o-rings.
Pump operates but output low on down stroke	Held open or worn fluid intake valve Damaged cylinder o-rings (13)	Clear or service fluid intake valve. Replace o-rings.
Pump operates but output low on up stroke	Held open or worn fluid piston or seal (19)	Clear or service fluid piston or seal.
Erratic or accelerated operation	Exhausted fluid supply Held open or worn fluid intake valve Held open or worn fluid piston or seal (19)	Refill fluid supply. Clear or service fluid intake valve. Clear or service fluid piston or seal.

# Service (Double Ball Pump)

## Disassembly

**NOTE:** Repair Kit 218741 is available. The parts included in the kit are marked with an asterisk (for example, 8\*). See page 15. Use all the parts in the kit for the best results.

1. Remove the pump from the fluid container. Operate it until as much of the fluid has been pumped out as possible.

### **WARNING**

To reduce the risk of serious injury whenever you are instructed to relieve pressure, always follow the **Pressure Relief Procedure** on page 7.

2. **Relieve the pressure** and remove the air and fluid hoses from the pump.
3. Remove the intake valve housing (18) by removing the retaining pin (16) and the o-rings (20) and pulling the valve out of the cylinder (2). Disassemble the valve. Clean and inspect the parts. See Fig. 3.
4. Release the clamp (7) holding the retainer housing (22) to the air motor base. Slide the displacement cylinder (2) down from the air motor and pull the displacement rod (3) out of the connecting rod (21). Inspect the connecting rod o-ring (28).
5. Push the displacement rod out through the bottom of the cylinder. Remove the piston housing (26) by removing the retaining pin (25) and the o-ring (20) and pulling the piston from the displacement rod. Disassemble, clean and inspect the parts.
6. Take the retainer housing (22) off of the cylinder (2) and remove the packing housing (24), bearing (17) and packing (8).
7. Clean and inspect all the parts. Refer to the **Cleaning Procedure** on page 8. Replace the parts as necessary.

### **WARNING**

Any damaged rubber parts **must** be replaced as they will harbor microorganisms that can contaminate the fluid.

## Reassembly

**NOTE:** Lubricate the o-rings, throat packings, and piston seals with waterproof approved sanitary lubricant when reassembling.

1. Install the u-cup packing (8\*) and throat bearing (17\*) in the throat packing housing (24). The lips of the u-cup must face down into the housing, and the lip of the bearing must face up. Install the o-ring (13\*) on the outside of the housing. See Detail A of Fig. 3.
2. Place the throat packing housing (24) on the top of the cylinder (2). Make sure the gasket (12\*) is in place on the top of the cylinder (2). Install the retainer housing (22) on the cylinder so the hole (A) in the housing is slanting downward toward the cylinder. Secure with the clamp (7).
3. Install the piston seal (19\*) on the piston housing (26). Place the ball (9) on the seat of the housing. Install the piston housing in the displacement rod (3) so the holes in both parts align. Secure with the retaining pin (25) and one o-ring (20\*). See Detail B.
4. Lubricate the connecting rod o-ring (28) with sanitary lubricant. See the parts drawing, page 14.
5. Slide the displacement rod (3) up through the cylinder (2) so it protrudes from the retainer housing (22). Install the gasket (12\*) on the top of the retainer housing. Make sure the drip shield (11) is in place on the connecting rod (21), then reconnect the displacement rod to the connecting rod.
6. Slide the retainer housing (22) and cylinder (2) up to the base of the air motor (1), and secure with the clamp (7). Make sure the drip shield (14) is in place on the cylinder.
7. Install the o-ring (13\*) on the intake valve housing (18). Place the ball (10) on the seat of the housing (18), and install the ball stop pin (23) in the top holes of the housing. See Detail C.
8. Slide the intake valve housing (18) up into the cylinder (2) until the bottom holes of the housing align with the holes in the cylinder. Secure using the retaining pin (16) and two o-rings (20\*).
9. Install the gasket (15\*) and clamp (5) when reconnecting the fluid line to the pump fluid outlet.
10. Reconnect the ground wire if it was disconnected during service.

# Service (Double Ball Pump)

- △1 See Detail A.
- △2 See Detail B.
- △3 See Detail C.
- △4 Lips must face up.
- △5 Lips must face down.
- △6 Lubricate with sanitary lubricant.

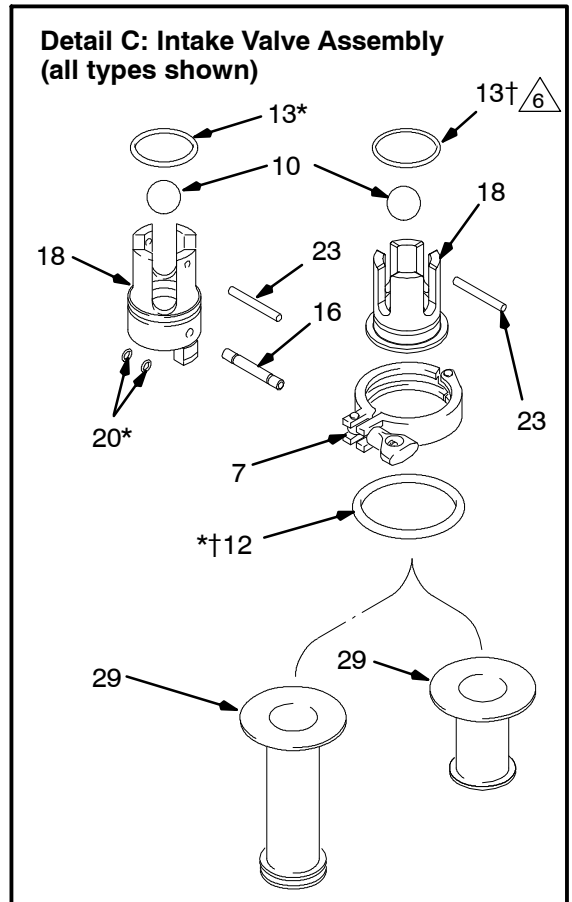
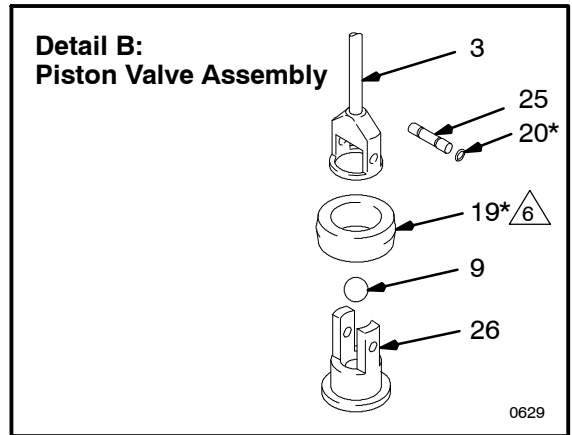
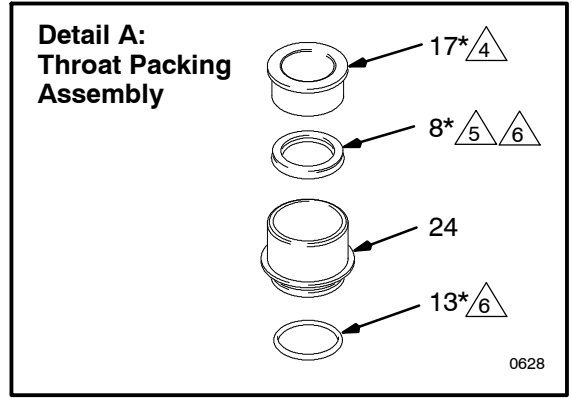
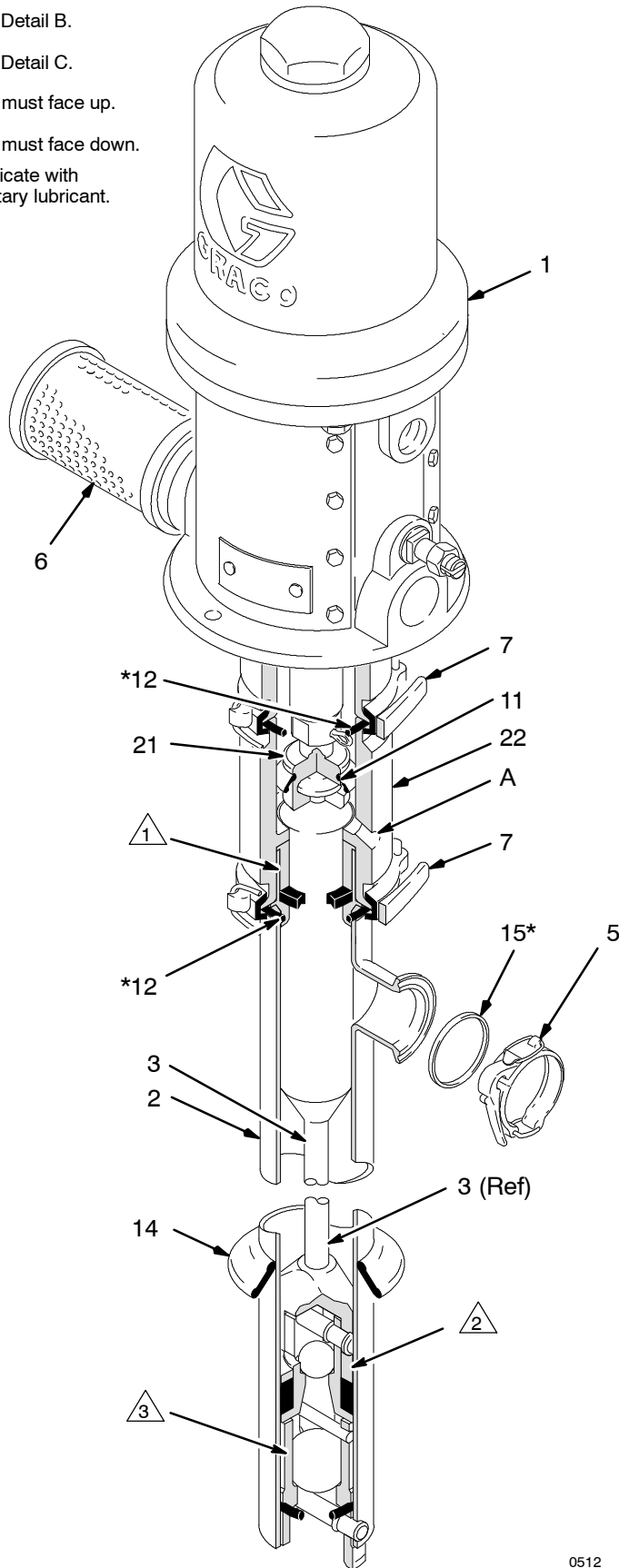

Fig. 3

# Service (Priming Piston Pump)

## Disassembly

**NOTE:** Repair Kit 948147 is available. The parts included in the kit are marked with an asterisk (for example, 8\*). See page 17. Use all the parts in the kit for the best results.

1. Remove the pump from the fluid container. Operate it until as much of the fluid has been pumped out as possible.

### **WARNING**

To reduce the risk of serious injury whenever you are instructed to relieve pressure, always follow the **Pressure Relief Procedure** on page 7.

2. **Relieve the pressure** and remove the air and fluid hoses from the pump.
3. Remove the retaining pin (37) from the priming piston rod (40). Release the clamp (7) to remove the intake valve housing (35) from the pump cylinder (2). Remove the gasket (12). See Fig. 4.
4. Slide the priming piston (36), poppet (34), packings (38), spring (39), bearing (32), and valve stop (33) off the priming piston rod (40).
5. Release the clamp (7) holding the retainer housing (22) to the air motor base. Remove the gasket (12). Slide the pump cylinder (2) down from the air motor. Pull the displacement rod (3) out of the connecting rod (21). Inspect the connecting rod o-ring (28).
6. Push the displacement rod out through the bottom of the cylinder.
7. Remove the retaining pin (25) and o-ring (20) and pull the priming piston rod (40) from the displacement rod (3). Remove the ball (9) and seal (19).
8. Release the clamp (7) and take the retainer housing (22) off the cylinder (2). Remove the packing housing (24), bearing (17), packing (8), o-ring (13), and gasket (12).
9. Clean and inspect all the parts. Refer to the **Cleaning Procedure** on page 8. Replace the parts as necessary.

### **WARNING**



Any damaged rubber parts **must** be replaced as they will harbor microorganisms that can contaminate the fluid.

## Reassembly

**NOTE:** Lubricate the o-rings, throat packings, and piston seals with waterproof approved sanitary lubricant when reassembling.

1. Install the v-block packing (8\*) and bearing (17\*) in the packing housing (24). The lips of the packing must face down into the housing, and the lip of the bearing must face up. Install the o-ring (13\*) on the outside of the housing. See Fig. 4.
2. Place the packing housing (24) on the top of the cylinder (2). Make sure the gasket (12\*) is in place on the top of the cylinder (2). Install the retainer housing (22) on the cylinder so the hole (A) in the housing is slanting downward toward the cylinder. Secure with the clamp (7).
3. Install the seal (19\*) on the piston valve housing at the top of the priming piston rod (40). Place the ball (9) on the seat of the housing. Install the displacement rod (3) over the top of the priming piston rod so the holes in both parts align. Secure with the retaining pin (25) and o-ring (20\*).
4. Lubricate the connecting rod o-ring (28) with sanitary lubricant.
5. Slide the displacement rod (3) up through the cylinder (2) so it protrudes from the retainer housing (22). Install the gasket (12\*) on the top of the retainer housing. Make sure the drip shield (11) is in place on the connecting rod (21), then reconnect the displacement rod to the connecting rod.
6. Slide the retainer housing (22) and cylinder (2) up to the base of the air motor (1), and secure with the clamp (7). Make sure the drip shield (14) is in place on the cylinder.
7. Slide the valve stop (33), bearing (32), spring (39), packings (38), poppet (34), and priming piston (36) onto the priming piston rod (40).
8. Install the gasket (12\*) on the intake valve housing (35). Secure the housing to the cylinder (2) with the clamp (7). Install the retaining pin (37) in the priming piston rod (40).
9. Reconnect the ground wire if it was disconnected during service.

# Service (Priming Piston Pump)

-  Lips must face up.
-  Lips must face down.
-  Lubricate with sanitary lubricant.

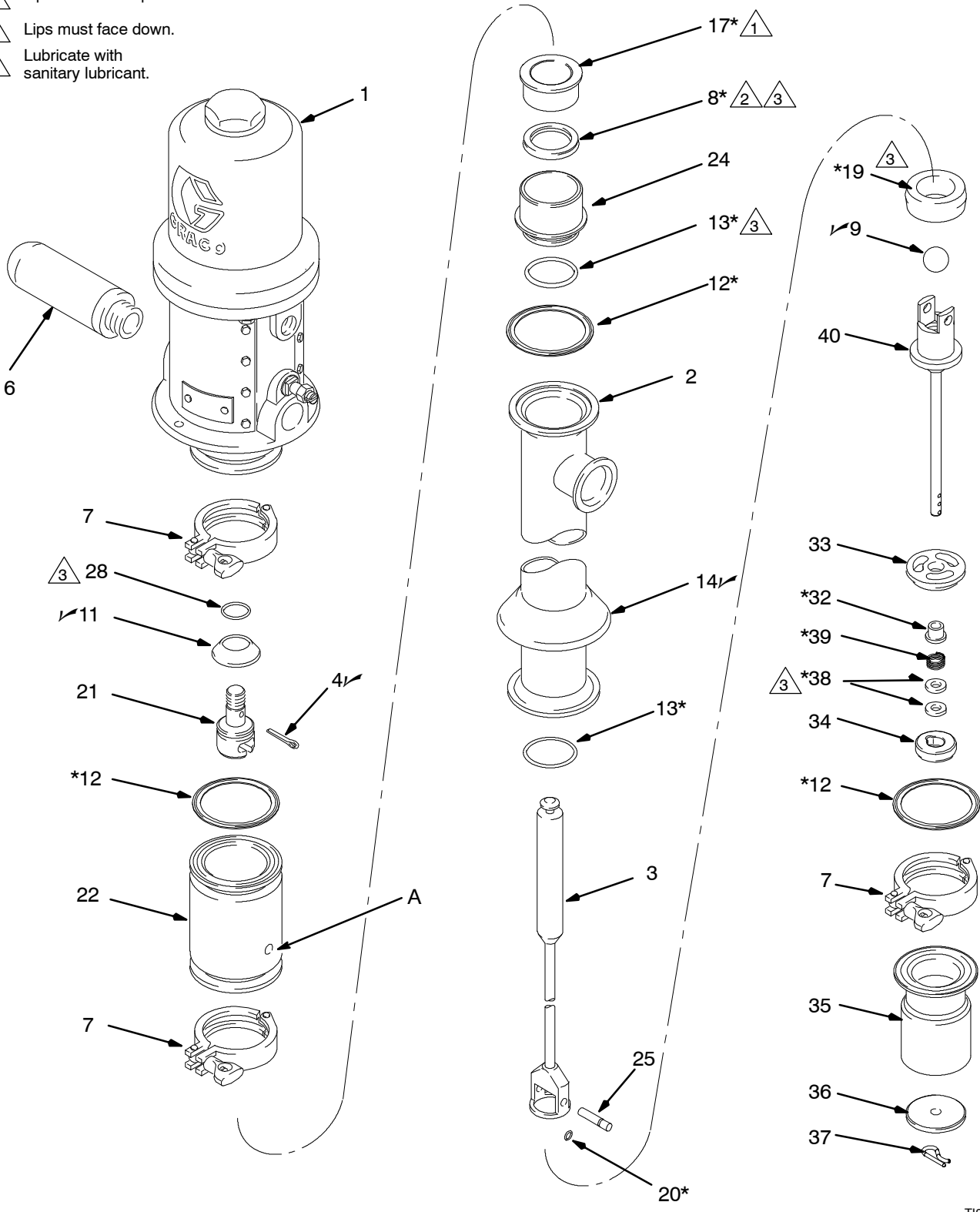

T12214B

Fig. 4

# Parts

207550, 903035, 954383, and 965520 Double Ball Pumps

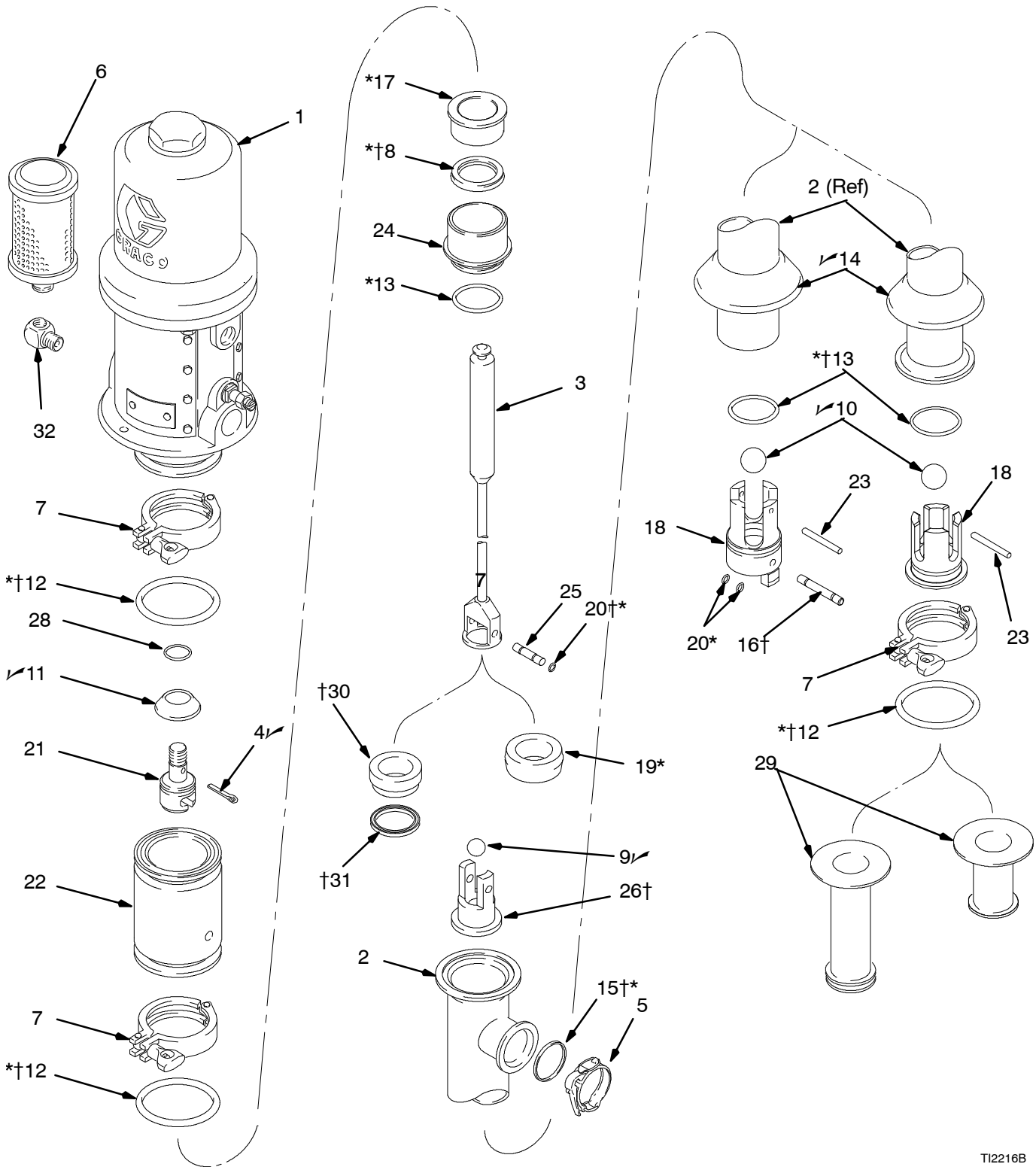

T12216B

# Parts

## 207550, 903035, 954383, and 965520 Double Ball Pumps

Ref No.	Part No.	Description	Qty	Ref No.	Part No.	Description	Qty
1	207546	AIR MOTOR See 307043 for parts	1	†	625916	PIN, retaining, intake valve (903035 only)	1
2	207551	CYLINDER, pump (207550, 903035)	1	17*	605752	BEARING, sleeve	1
	902980	CYLINDER, pump (954383, 965520)	1	18	167970	HOUSING, intake valve (207550, 903035)	1
3	207552	ROD, displacement (207550, 903035)	1	902979	HOUSING, intake valve (954383, 965520)	1	
	902981	ROD, displacement (954383, 965520)	1	19*	167971	SEAL, piston; neoprene (207550)	1
4✓	101946	PIN, cotter; 0.12" (3.2 mm) x 1" (25 mm)	1	622142	SEAL, piston; UHMWPE (954383)	1	
5	102218	CLAMP, hinged; 1.5" (3.8 mm) (207550, 954383, 965520)	1	20*	167972	O-RING; nitrile rubber (3 are spares) (207550, 954383)	6
6	102656	MUFFLER, air exhaust (207550, 903035)	1	†	551008	RING, retaining; sst (903035, 965520)	3
	512913	MUFFLER, air exhaust (954383, 965520)	1	21	167974	ROD, connecting	1
7	620223	CLAMP, hinged; 2.5" (64 mm) (207550, 903035)	2	22	167975	HOUSING, retainer	1
	620223	CLAMP, hinged; 2.5" (64 mm) (954383, 965520)	3	23	169626	PIN, straight headless	1
8*	180238	PACKING, v-block; buna-N (207550)	1	24	180918	HOUSING, packing	1
	178140	PACKING, u-cup; UHMWPE; (954383)	1	25	169845	PIN, retaining, piston housing (207550, 954383)	1
†	605753	PACKING, u-cup; PTFE (903035, 965520)	1		17F349	PIN, retaining, piston housing (903035, 965520)	1
9✓	103462	BALL; 0.75" (19 mm) dia.	1	26	169846	HOUSING, piston (207550, 954383)	1
10✓	103869	BALL; 1.25" (31.8 mm) dia.	1	†	605837	HOUSING, piston (903035, 965520)	1
11✓	166114	SHIELD, drip; neoprene	1	28	156082	O-RING; buna-N	1
12*	166117	GASKET; 2.5" (64 mm) dia.; buna-N (207550)	2	29	511192	ADAPTER, intake, sanitary; 3 in.; (954383, 965520 only)	1
	166117	GASKET; 2.5" (64 mm) dia.; buna-N (954383)	3	30†	605756	SPACER; sst (903035, 965520 only)	1
†	502598	GASKET; 2.5" (64 mm) dia.; PTFE (903035)	2	31†	605754	PACKING, piston, u-cup; PTFE (903035, 965520)	1
	502598	GASKET; 2.5" (64 mm) dia.; PTFE (965520)	3	32	166590	ELBOW, street (903035 only)	1
13*	166119	O-RING; neoprene (1 is a spare) (207550, 954383)	3	* . These parts are included in Buna-N Repair Kit 218741, which may be purchased separately for Part No. 207550 Pump.			
†	164846	O-RING; PTFE (903035)	2	Part No. 207550 Pump, Series D and earlier, uses part no. 167969 throat bearing (ref. no. 17) and an old style throat packing housing. Order Repair Kit 208497.			
	164846	O-RING; PTFE (1 is a spare) (965520)	3				
14✓	166129	SHIELD, drip; neoprene	1				
15*	166130	GASKET; 1.5" (38 mm) dia.; buna-N (207550, 954383)	1				
†	680454	GASKET; 1.5" (38 mm) dia.; PTFE (903035, 965520)	1	† . These parts are included in PTFE Repair Kit 904427, which may be purchased separately for part No. 903035 and 965520 Pumps.			
16	167968	PIN, retaining, intake valve (207550 only)	1	✓ Keep these spare parts on hand to reduce down-time.			

# Parts

## 952793 Priming Piston Pump

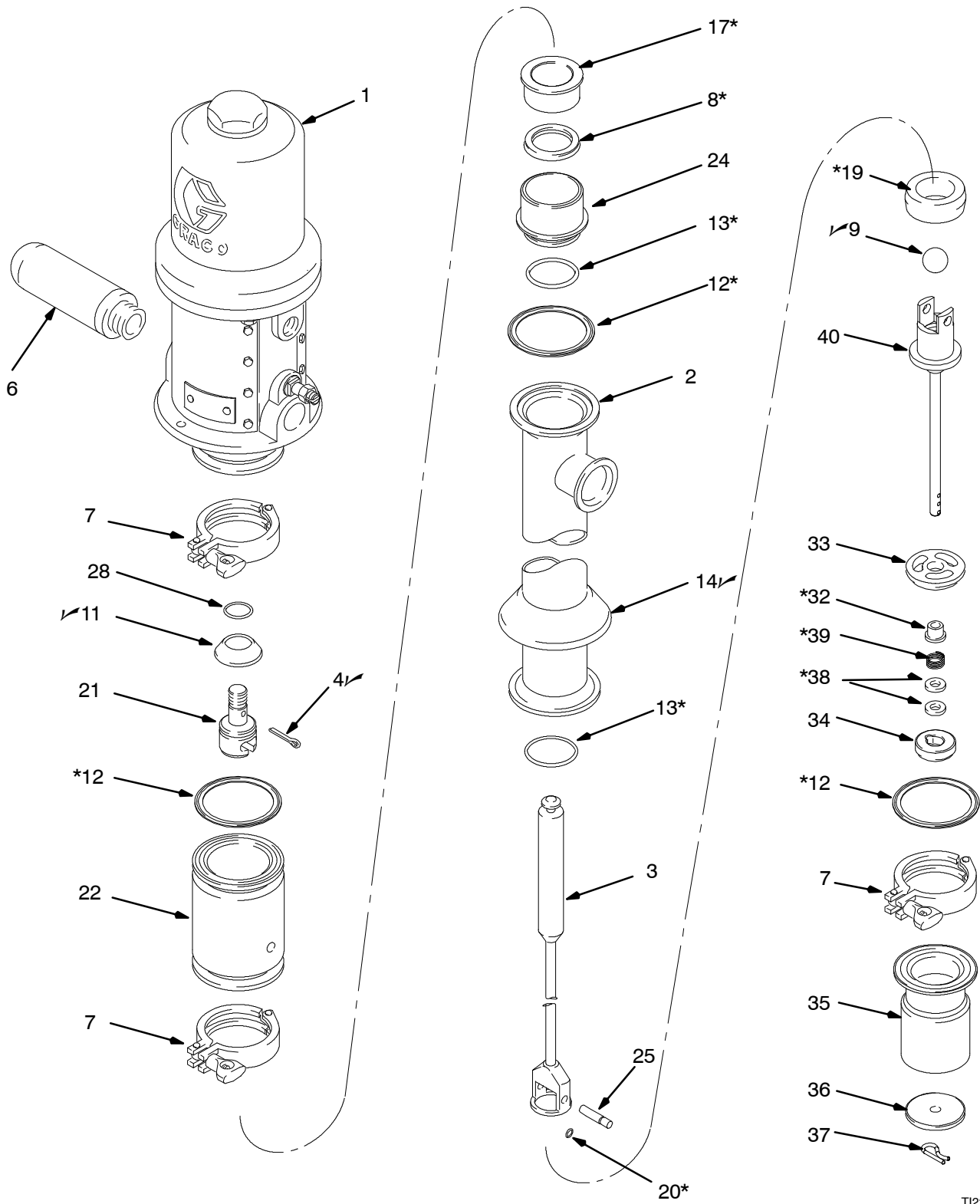

T12214B



# Parts

## 952793 Priming Piston Pump

Ref No.	Part No.	Description	Qty	Ref No.	Part No.	Description	Qty
1	207546	AIR MOTOR See 307043 for parts	1	21	167974	ROD, connecting	1
2	902980	CYLINDER, pump	1	22	167975	HOUSING, retainer	1
3	902983	ROD, displacement	1	24	180918	HOUSING, packing	1
4✓	101946	PIN, cotter; 0.12" (3.2 mm) x 1" (25 mm)	1	25	169845	PIN, retaining	1
6	512913	MUFFLER, air exhaust	1	28	156082	O-RING; buna-N	1
7	620223	CLAMP, hinged; 2.5" (64 mm)	3	32*	604016	BEARING, priming piston	1
8*	180238	PACKING, v-block; buna-N	1	33	195215	STOP, intake valve	1
9✓	103462	BALL; 0.75" (19 mm) dia.	1	34	604018	POPPET, intake valve	1
11✓	166114	SHIELD, drip; neoprene	1	35	195213	HOUSING, intake valve	1
12*	166117	GASKET; 2.5" (64 mm) dia.; buna-N	3	36	195214	PISTON, priming	1
13*	166119	O-RING; neoprene	1	37	604008	PIN, retaining, priming piston	1
14✓	166129	SHIELD, drip; neoprene	1	38*	603778	PACKING, intake valve; neoprene	2
17*	605752	BEARING, sleeve	1	39*	501095	SPRING, ball check	1
19*	167971	SEAL, piston; neoprene	1	40	195216	ROD, priming piston	1
20*	167972	O-RING; nitrile rubber (2 are spares)	3				

\* These parts are included in Repair Kit 948147, which may be purchased separately.

✓ Keep these spare parts on hand to reduce down time.

# Dimensions

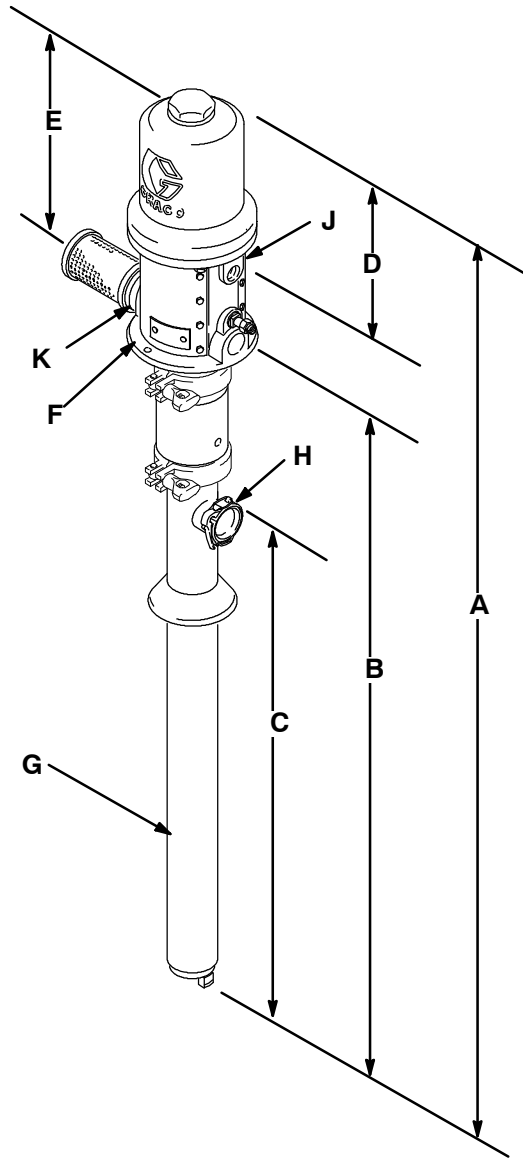

Model 207550 Shown

0333B

Pump	A in. (mm)	B in. (mm)	C in. (mm)	D in. (mm)	E in. (mm)	F (dia.) in. (mm)	G (dia.) in. (mm)	H (fluid out- let tube size )	J (air inlet)	K (exhaust)
207550	56.8 (1443)	45 (1143)	36.7 (933)	7.88 (201)	11 (280)	5.69 (145)	2.12 (54)	1-1/2 in.	3/8 npt(f)	3/4 npt(f)
903035	56.8 (1443)	45 (1143)	36.7 (933)	7.88 (201)	11 (280)	5.69 (145)	2.12 (54)	1-1/2 in.	3/8 npt(f)	3/4 npt(f)
954383	35.8 (910)	24.0 (610)	15.9 (404)	7.88 (201)	11 (280)	5.69 (145)	2.12 (54)	1-1/2 in.	3/8 npt(f)	3/4 npt(f)
965520	35.8 (910)	24.0 (610)	15.9 (404)	7.88 (201)	11 (280)	5.69 (145)	2.12 (54)	1-1/2 in.	3/8 npt(f)	3/4 npt(f)
952793	need info	need info	need info	7.88 (201)	11 (280)	5.69 (145)	2.12 (54)	1-1/2 in.	3/8 npt(f)	3/4 npt(f)

# Technical Data

Category	Data
Maximum fluid working pressure	600 psi (41 bar)
Maximum air input pressure	120 psi (8 bar)
Ratio	5:1
Pump cycles per gallon (3.8 liters)	28
Fluid flow at 60 cycles per minute	2.3 gallons (8.7 liters)
Air consumption	approximately 8 scfm (0.224 m <sup>3</sup> /minute) per gallon (3.8 liters) at 100 psi (7 bar) air pressure
Minimum air hose size	0.5 in. (13 mm) ID
Maximum operating temperature for displacement pump	250°F (121°C)
Maximum operating temperature for air motor	200°F (93°C)
Weight	33 lb (15 kg)
Wetted parts	Stainless steel, buna-N, neoprene (USDA approved)

# Graco Standard Warranty

Graco warrants all equipment manufactured by Graco and bearing its name to be free from defects in material and workmanship on the date of sale to the original purchaser for use. With the exception of any special, extended, or limited warranty published by Graco, Graco will, for a period of twelve months from the date of sale, repair or replace any part of the equipment determined by Graco to be defective. This warranty applies only when the equipment is installed, operated and maintained in accordance with Graco's written recommendations.

This warranty does not cover, and Graco shall not be liable for general wear and tear, or any malfunction, damage or wear caused by faulty installation, misapplication, abrasion, corrosion, inadequate or improper maintenance, negligence, accident, tampering, or substitution of non-Graco component parts. Nor shall Graco be liable for malfunction, damage or wear caused by the incompatibility of Graco equipment with structures, accessories, equipment or materials not supplied by Graco, or the improper design, manufacture, installation, operation or maintenance of structures, accessories, equipment or materials not supplied by Graco.

This warranty is conditioned upon the prepaid return of the equipment claimed to be defective to an authorized Graco distributor for verification of the claimed defect. If the claimed defect is verified, Graco will repair or replace free of charge any defective parts. The equipment will be returned to the original purchaser transportation prepaid. If inspection of the equipment does not disclose any defect in material or workmanship, repairs will be made at a reasonable charge, which charges may include the costs of parts, labor, and transportation.

**THIS WARRANTY IS EXCLUSIVE, AND IS IN LIEU OF ANY OTHER WARRANTIES, EXPRESS OR IMPLIED, INCLUDING BUT NOT LIMITED TO WARRANTY OF MERCHANTABILITY OR WARRANTY OF FITNESS FOR A PARTICULAR PURPOSE.**

Graco's sole obligation and buyer's sole remedy for any breach of warranty shall be as set forth above. The buyer agrees that no other remedy (including, but not limited to, incidental or consequential damages for lost profits, lost sales, injury to person or property, or any other incidental or consequential loss) shall be available. Any action for breach of warranty must be brought within two (2) years of the date of sale.

Graco makes no warranty, and disclaims all implied warranties of merchantability and fitness for a particular purpose in connection with accessories, equipment, materials or components sold but not manufactured by Graco. These items sold, but not manufactured by Graco (such as electric motors, switches, hose, etc.), are subject to the warranty, if any, of their manufacturer. Graco will provide purchaser with reasonable assistance in making any claim for breach of these warranties.

In no event will Graco be liable for indirect, incidental, special or consequential damages resulting from Graco supplying equipment hereunder, or the furnishing, performance, or use of any products or other goods sold hereto, whether due to a breach of contract, breach of warranty, the negligence of Graco, or otherwise.

## **FOR GRACO CANADA CUSTOMERS**

The parties acknowledge that they have required that the present document, as well as all documents, notices and legal proceedings entered into, given or instituted pursuant hereto or relating directly or indirectly hereto, be drawn up in English. Les parties reconnaissent avoir convenu que la rédaction du présente document sera en Anglais, ainsi que tous documents, avis et procédures judiciaires exécutés, donnés ou intentés à la suite de ou en rapport, directement ou indirectement, avec les procédures concernées.

## Graco Information

**TO PLACE AN ORDER**, contact your Graco distributor, or call this number to identify the distributor closest to you:

**1-800-328-0211 Toll Free**

**612-623-6921**

**612-378-3505 Fax**

*For the latest information about Graco products, visit [www.graco.com](http://www.graco.com).*

*For patent information, see [www.graco.com/patents](http://www.graco.com/patents).*

*All written and visual data contained in this document reflects the latest product information available at the time of publication.*

*Graco reserves the right to make changes at any time without notice.*

Original instructions. This manual contains English. MM 307056

**Graco Headquarters:** Minneapolis

**International Offices:** Belgium, China, Japan, Korea

**GRACO INC. AND SUBSIDIARIES • P.O. BOX 1441 • MINNEAPOLIS MN 55440-1441 • USA**  
**Copyright 1971, Graco Inc. All Graco manufacturing locations are registered to ISO 9001.**

[www.graco.com](http://www.graco.com)

Revision U, December 2017