



# SERVICE/OPERATION MANUAL



# TABLE OF CONTENTS

## Introduction

Field Stripe Pro Specifications .....	1
Safety Warnings .....	2

## Getting Started

Flushing .....	6
How to Flush .....	7
Setting Up .....	8
Starting Up .....	9
Daily Maintenance .....	10
Pressure Relief Procedure .....	11

## Repairs/Maintenance Instructions

Line Striping Operation .....	12
Spray Gun Operation .....	13
Spray Gun Troubleshooting .....	14
Line Striping Tip Chart.....	15
Oil & Lubrication Procedure.....	16
Troubleshooting .....	16
Servicing Fluid Pump.....	17
Servicing Upper/Lower Check Valves .....	18
Packing Replacement .....	19
Troubleshooting	
Clutch Does Not Engage.....	22
Replacement of Electrical	
Control Board .....	23
Pressure Calibration for	
Electrical Control Board .....	23
Clutch Replacement .....	24

## Product Diagrams & Parts Lists

Fluid Pump .....	21
Ball Valve .....	22
Clutch Assembly .....	25
Engine Sheave Assembly .....	25
Manifold Filter .....	26
Suction Assembly .....	26
Field Stripe Pro Parts List .....	27
First Gun Assembly .....	28
Second Gun Assembly.....	28
Field Stripe Pro Brake Assembly.....	29
Gun Holder Assembly.....	29
Lock Assembly.....	30
Field Stripe Pro Swivel Wheel .....	30
Power Unit Assembly.....	31
Paint System Assembly.....	32



# INTRODUCTION



FIELD STRIPE PRO 2-Gun Model Shown with a 2nd for spraying stencils, the other gun on floating mount ready for striping.

## Specifications:

Power	Honda OHV 5.5 HP with Oil Alert
Max pressure	0-3000 PSI (205 Bar)
Max Output	1.5 GPM (5.67 Litres/min.)
Gallonage	5000 per year
Max Tip	1 gun @ 0.039 inch 2 gun @ 0.028 inch
Max Width	1 gun @ 0.039 inch - 12" (30cm) line 2 gun @ 0.028 inch - 24" (60cm) line

## Advantages & Features

- Move complete gun assembly in one piece in seconds from left to right, no tools needed.
- Handlebar mounted caster lock release.
- Adjustable height handle attaches to either end of the striper frame. Allows the striper to have a trailing swivel wheel when desired.
- Adjustable gun fences block wind & save material
- Gun rolls across turf on a pivoting arm so line is consistent width regardless of field condition.
- Extra large pneumatic tires with tapered bearings for smooth rolling across bumpy surfaces.
- Simple turnbuckles are used to preset straight lines or circles (such as 10 yard radius for circles on soccer fields). Once measured, a circle can be repeated by simply adding a preset turnbuckle to the caster assembly.
- The FIELD STRIPE Pro uses our high-performance 1.5 GPM "Slow-Stroking" paint pump designed for everyday duty of up to 5000 gallons per year! A large diameter 1-piece piston along with Airlessco's patented Triple-Life Packing System results in reduced maintenance, lower operating costs, and longer equipment life.

## IMPORTANT WARNING !!

**HANDLE THIS UNIT AS YOU WOULD A LOADED FIREARM!!**  
High pressure spray can cause extremely serious injury.  
**OBSERVE ALL WARNINGS!**

Before operating this unit, read and follow all safety warnings and instructions related to the usage of this equipment. **READ, LEARN, and FOLLOW** the Pressure Relief Procedure on Page 11 and understand all warnings on pages 2,3,4 & 5.

All Service Procedures to be performed by an Authorized Airlessco Service Center **ONLY**.  
**NO MODIFICATIONS** or alterations of any Airlessco Equipment or part is allowed.

# SAFETY WARNINGS

**HIGH PRESSURE SPRAY CAN CAUSE EXTREMELY SERIOUS INJURY.  
OBSERVE ALL WARNINGS. THIS SPRAYER IS FOR PROFESSIONAL USE ONLY.**

## **INJECTION HAZARD**

**Fluids under high pressure from spray or leaks can penetrate the skin and cause extremely serious injury, including the need for amputation.**

- **NEVER** point the spray gun at anyone or any part of the body.
- **NEVER** put hands or fingers over the spray tip. Do not use a rag or any other material over your fingers. Paint will penetrate through material and into the hand.
- **NEVER** try to stop or deflect leaks with your hand or body.
- **NEVER** try to "blow back" paint, this is not an air spray sprayer.
- **ALWAYS** have gun tip guard in place when spraying.
- **ALWAYS** lock gun trigger when you stop spraying.
- **ALWAYS** remove tip from the gun to clean it.
- **ALWAYS** follow the **PRESSURE RELIEF PROCEDURE**, as shown on page 11, before cleaning or removing the spray tip or servicing any system equipment.
- **ALWAYS** Be sure equipment safety devices are operating properly before each use.
- **ALWAYS** tighten all fluid connections before each use.

## **MEDICAL TREATMENT**

***If any fluid appears to penetrate your skin, get EMERGENCY CARE AT ONCE. DO NOT TREAT AS A SIMPLE CUT.***

- \* Go to an emergency room immediately.
- \* Tell the doctor you suspect an injection injury.
- \* Tell him what kind of material you were spraying with and have him read NOTE TO PHYSICIAN.

### **MEDICAL ALERT - Airless Spray Wounds**

*If any fluid appears to penetrate your skin, get EMERGENCY MEDICAL CARE AT ONCE. DO NOT TREAT AS A SIMPLE CUT. Tell the doctor exactly what fluid was injected. Have him read the following "NOTE TO PHYSICIAN".*

### **NOTE TO PHYSICIAN:**

*Injection in the skin is a traumatic injury. It is important to treat the injury surgically as soon as possible. DO NOT DELAY treatment to research toxicity. Toxicity is a concern with some exotic coatings injected directly into the bloodstream. Consultation with a plastic surgeon or reconstructive hand surgeon may be advisable.*

## **GENERAL PRECAUTIONS**

- **NEVER** alter equipment in any manner.
- **NEVER** spray highly flammable materials.
- **NEVER** allow another person to use sprayer unless they are thoroughly instructed on safety use and given this operators manual to read.
- **ALWAYS** wear a spray mask, gloves and protective eye wear while spraying.
- **ALWAYS** ensure fire extinguishing equipment is readily available and properly maintained.
- **NEVER** smoke while in spraying area.
- **NEVER** use around children.

***NEVER LEAVE SPRAYER UNATTENDED WITH PRESSURE IN THE SYSTEM. FOLLOW PRESSURE RELIEF PROCEDURES ON PAGE 11.***

# SAFETY WARNINGS

## TOXIC FLUID HAZARD

Hazardous fluid or toxic fumes can cause serious injury or death if splashed in eyes or on skin, inhaled or swallowed. Know the hazards of the fluid you are using. Store & dispose of hazardous fluids according to manufacturer, local, state & national guidelines. ALWAYS wear protective eyewear, gloves, clothing and respirator as recommended by fluid manufacturer.

## ALWAYS INSPECT SPRAYING AREA

- **ALWAYS** keep spraying area free from obstructions.
- **ALWAYS** make sure area has good ventilation to safely remove vapors and mists.
- **NEVER** keep flammable material in spraying area.
- **NEVER** spray in vicinity of open flame or other sources of ignition.

## SPRAY GUN SAFETY

- **ALWAYS** set safety lock on the gun in "LOCKED" position when not in use and before servicing or cleaning.
- **NEVER** remove or modify any part of the gun.
- **ALWAYS** REMOVE SPRAY TIP when cleaning. Flush unit with LOWEST POSSIBLE PRESSURE.
- **ALWAYS** check operation of all gun safety devices before each use.
- Be very careful when removing the spray tip or hose from gun. A plugged line contains fluid under pressure. If the tip or line is plugged, follow the PRESSURE RELIEF PROCEDURE as outlined on page 11.

## TIP GUARD

ALWAYS have the tip guard in place on the spray gun while spraying. The tip guard alerts you to the injection hazard and helps prevent accidentally placing your fingers or any part of your body close to the spray tip.

## SPRAY TIP SAFETY

Use extreme caution when cleaning or changing spray tips. If the spray tip clogs while spraying, engage the gun safety latch immediately.

- **ALWAYS** follow the PRESSURE RELIEF PROCEDURE and then remove the spray tip to clean it.
- **NEVER** wipe off build up around the spray tip.
- **ALWAYS** remove tip & tip guard to clean AFTER pump is turned off and the pressure is relieved by following the PRESSURE RELIEF PROCEDURE.

## KEEP CLEAR OF MOVING PARTS

Keep clear of moving parts when starting or operating the sprayer. Do not put your fingers into any openings to avoid amputation by moving parts or burns from hot parts.

Precaution is the best insurance against an accident.

When starting the engine, maintain a safe distance from moving parts of the equipment.

Before adjusting or servicing any mechanical part of the sprayer, follow the PRESSURE RELIEF PROCEDURE, and remove the ignition cable from the spark plug to prevent accidental starting of the sprayer.

## LABELING

Keep all labels on the unit clean and readable. Replacement labels are available from the manufacturer.

# SAFETY WARNINGS

## GROUNDING

Ground the sprayer and other components in the system to reduce the risk of static sparking, fire or explosion which can result in serious bodily injury and property damage.

### Always ground all of these components:

- **Sprayer:** Be sure grounding chain (supplied) is in contact with the ground.
- **Fluid Hose:** use only grounded hoses.
- **Spray gun or dispensing valve:** grounding is obtained through connection to a properly grounded fluid hose and pump.
- **Object being sprayed:** according to your local code.
- All solvent pails used when flushing should only be metal pails which are conductive.

Once each week, check electrical resistance of hose (when using multiple hose assemblies, check overall resistance of unpressurized hose must not exceed 29 megohms (max) for any coupled length or combination of hose lengths. If hose exceeds these limits, replace it immediately.

Never exceed 500 Ft. (150 m.) overall combined hose length to assure electrical continuity.

## AVOID COMPONENT RUPTURE

This sprayer operates at 3000 psi (205 bar). Always be sure that all components and accessories have a maximum working pressure of at least 3000 psi to avoid rupture which can result in serious bodily injury including injection and property damage.

- **NEVER** leave a pressurized sprayer unattended to avoid accidental operation of it which could result in serious bodily injury.
- **ALWAYS** follow the PRESSURE RELIEF PROCEDURE whenever you stop spraying and before adjusting, removing or repairing any part of the sprayer.
- **NEVER** alter or modify any part of the equipment to avoid possible component rupture which could result in serious bodily injury and property damage.
- **NEVER** use weak, damaged or non-conductive paint hoses. Do not allow kinking or crushing of hoses or allow it to vibrate against rough, sharp or hot surfaces. Before each use, check hoses for damage and wear and ensure all fluid connections are secure.
- **REPLACE** any damaged hose. NEVER use tape or any device to mend the hose.
- **NEVER** attempt to stop any leakage in the line or fittings with your hand or any part of the body. Turn off the unit and release pressure by following PRESSURE RELIEF PROCEDURE on page 11.
- **ALWAYS** use approved high pressure fittings and replacement parts.
- **ALWAYS** ensure fire extinguishing equipment is readily available and properly maintained.

## WARNING

***Do not use halogenated solvents in this system. The prime valve, 2 gun manifold and most airless guns have aluminum parts and may explode. Cleaning agents, coatings, paints or adhesives may contain halogenated hydrocarbon solvents. DON'T TAKE CHANCES! Consult your material suppliers to be sure. Some of the most common of these solvents are: Carbontetrachloride, Chlorobenzene, Dichloroethane, Dichloroethyl Ether, Ethylbromide, Ethylchloride, Tetrachloroethane. Alternate valves and guns are available if you need to use these solvents.***

# SAFETY WARNINGS

## FLUSHING

Reduce the risk of injection injury, static sparking or splashing by following the specific cleaning procedure on page 7.

- **ALWAYS** follow the PRESSURE RELIEF PROCEDURE on page 11.
- **ALWAYS** remove the spray tip before flushing. Hold a metal part of the gun firmly to the side of a metal pail and use the lowest possible fluid pressure during flushing.
- **NEVER** use cleaning solvents with flash points below 140° F. Some of these are: acetone, benzene, ether, gasoline and naphtha. Consult your supplier to be sure.

## PREVENT STATIC SPARKING FIRE/ EXPLOSIONS

ALWAYS be sure all equipment and objects being sprayed are properly grounded. Always ground sprayer, paint bucket and object being sprayed. See "grounding" on page 4 for detailed grounding information.

Vapors created when spraying can be ignited by sparks. To reduce the risk of fire, always locate the sprayer at least 20 feet (6 m.) away from the spray area. Do not plug in or unplug any electrical cords in the spray area, this can create sparks when there is any chance of igniting vapors still in the air. Follow the coating & solvent manufacturers safety warnings and precautions.

Use only conductive fluid hoses for airless applications. Be sure gun is grounded through hose connections. Check ground continuity in hose & equipment. Overall (end to end) resistance of unpressurized hose must not exceed 29 megohms for any coupled length or combination of hose length. Use only high pressure airless hoses with static wire approved for 3000 psi.

## GAS ENGINE PRECAUTIONS

Locate unit 25 feet away from spray area in well ventilated area.

- **NEVER** operate in closed buildings unless exhaust is piped outside.
- **NEVER** allow hose to lay against engine mufflers or hot parts.
- **NEVER** refill fuel tank while engine is hot or is running.

***Important: United States Government safety standards have been adopted under the Occupational Safety & Health Act. These standards, particularly the General Standards, Part 1910, & the Construction Standards, part 1926 should be consulted.***

### WHEN SPRAYING & CLEANING WITH FLAMMABLE PAINTS OR PAINT THINNERS:

1. When spraying with flammable liquids, the unit must be located a minimum of 25 feet away from the spraying area in a well ventilated area. Ventilation must be sufficient enough to prevent the accumulation of vapors.
2. To eliminate electrostatic discharge, ground the spray unit, paint bucket and spraying object. Use only high pressure airless hoses approved for 3000 psi which is conductive.
3. Remove spray tip before cleaning gun and hose. Make contact of gun with bucket and spray without the tip in a well ventilated area, into the grounded steel bucket.
4. Never use high pressure in the cleaning process. USE MINIMUM PRESSURE.
5. Do not smoke in spraying/cleaning area.

# FLUSHING

## Read prior to using your sprayer

### 1. New Sprayer

Your Airlessco unit was factory tested in an antifreeze solution which was left in the pump. Before using oil-base paint, flush with mineral spirits only. Before using water-base paint flush with soapy water, then do a clean water flush.

### 2. Changing Colors

Flush with a compatible solvent such as mineral spirits or water.

### 3. Changing from water-base to oil-base paint.

Flush with soapy water, then mineral spirits.

### 4. Changing from oil-base to water-base paint.

Flush with mineral spirits, followed by soapy water, then do a clean water flush.

### 5. Storage

**Oil-base paint:** Flush with mineral spirits.

**Water-base paint:** Flush with water, then mineral spirits and leave the pump, hose and gun filled with mineral spirits. For longer storage, use mixture of mineral spirits and motor oil (half & half). Shut off the sprayer, follow Pressure Relief Procedure on page 11 to relieve pressure and make sure prime valve is left OPEN.

### 6. Start up after storage

Before using water-base paint, flush with soapy water and then do a clean water flush. When using oil-base paint, flush out the mineral spirits with the material to be sprayed.



# HOW TO FLUSH

**FIGURE 1**

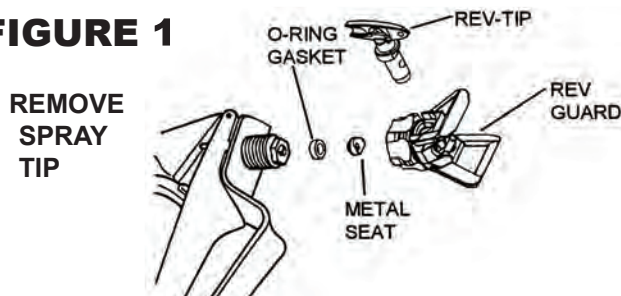

**FIGURE 2**

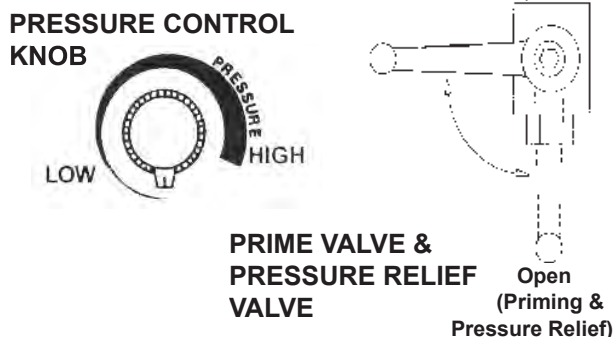

**FIGURE 3**

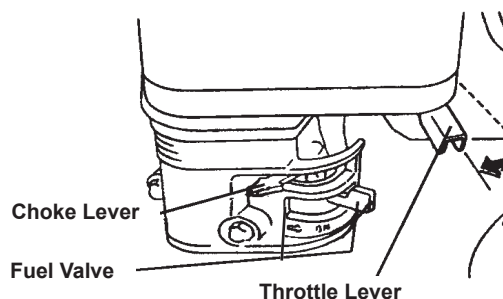

**FIGURE 4**

**MAINTAIN FIRM METAL TO METAL CONTACT BETWEEN GUN AND CONTAINER**



1. Be sure the gun safety latch is engaged and there is no spray tip in the gun. Refer to Fig. 1. Refer to your separate instruction manual provided with your gun on its safety features and how to engage safety latch.
2. Pour enough clean, compatible solvent into a large, empty metal pail to fill the pump and hoses.
3. Place the suction tube into the pail or place the pail under the pump.
4. Turn the pressure control knob to low pressure. Refer to Fig. 2.
5. Open the prime valve to the open - "Priming Position". This will allow an easy start. Refer to Fig.2.
6. Turn the engine ON/OFF switch to ON.
7. Move the choke to the closed position as per Fig.3.
8. Move the throttle lever slightly to the left as per Fig.3.
9. Turn the fuel valve ON as per Fig. 3. Pull the start rope. Pull the engine over against compression stroke and then let the rope rewind slowly into the starter. Pull firmly and rapidly to start the engine. Do NOT drop the rope. Hold onto the handle while rewinding, or the rope may rewind improperly and jam the assembly. If the engine does not start, open the choke half way. If the engine floods, open the choke all the way and continue cranking.
10. After the engine is warm, gradually open the choke lever, increase the RPM of engine by moving throttle all the way to the left. Close the prime valve. Refer to Fig. 2
11. Point the gun into the metal pail and hold a metal part of the gun firmly against the pail Refer to fig. 4.

## WARNING

*To reduce the risk of static sparking, which can cause fire or explosion, always hold a metal part of the gun firmly against the metal pail when flushing. This also reduces splashing. Refer to Fig.4.*

12. Disengage the gun safety latch and squeeze the gun trigger. At the same time, slowly turn the pressure control knob clockwise just enough to move liquid at low pressure.
13. Allow the pump to operate until clean solvent comes from the gun.
14. Release the trigger and engage the gun safety latch.
15. If you are going to start spraying, place the pump or suction tube into the supply container. Release the gun safety latch and trigger the gun into another empty, metal container, holding a metal part of the gun firmly against the metal pail (Fig. 4) and force the solvent from the pump and hose. When paint starts coming from the gun, turn pressure control knob to minimum pressure, place prime valve in prime (open) position and engage the gun safety latch.
16. If you are going to store the sprayer, remove the suction tube or pump from the solvent pail force the solvent from the pump and hose. Engage the gun safety latch and refer to the "Storage" Procedure on page 6. Step 5.
17. Whenever you shut off the sprayer follow the Pressure Relief Procedure warning on page 11.

# SETTING UP

## 1. Attach handle assembly.

- a. Choose which side the handle will be mounted. The handle can be affixed over the single wheel assembly or on the opposite side towards the large tires. The latter is the usual set up.
- b. Line up the mounting holes on the front forks of the handle with the mounting holes on the frame.
- c. Insert the two bolts through the front forks and the frame. Slide on washer and loosely screw on the nuts. Do not fully tighten the nuts.
- d. Place the four bolts in the frame and handle adjustment slots, slide on washer and loosely tighten the nuts. Do not fully tighten the nuts.
- e. Adjust handle the preferred height and tighten all six mounting bolts.

## 2. Install the gun arm assembly.

- a. Select the location that the gun arm will be place. The location depends on the type striping to be done. (See Linestripping Operations). The standard location is in the right front position.
- b. Position clamp assembly over the selected gun arm location and place the gun arm assembly into the frame mounting hole and the clamp assembly.
- c. Tighten clamp assembly handle to secure the gun arm assembly.

## 3. Keep the Packing Nut/Wet Cup lubricated with Airlessco Throat Seal Oil (TSO) at all times. ↓

FIGURE 5



## 4. Check the Engine Oil Level.

- a. Unscrew the oil fill plug. The dipstick is attached to the plug.
- b. Without threading the plug into place, check to be sure the oil is up to the top mark on the dipstick.
- c. If oil is needed, refer to engine manual.

## 5. Fill the Fuel Tank

### WARNING

*Fuel spilled on a hot surface can cause a fire or explosion and cause serious bodily injury and property damage. Always shut off the engine and let it cool before filling the tank, and carefully follow Steps a-c below, being sure not to spill any fuel.*

- a. Close the fuel shutoff valve.
- b. Use only clean, fresh, well-known brands of unleaded regular grade gasoline.
- c. Remove the fuel cap and fill tank, Be sure the air vent in the fill cap is not plugged so fuel can flow to the carburetor, then replace the cap.

## 6. Flush the sprayer.

See "Flushing" page 6 & 7. Your new pump was factory tested in an ant-freeze solution and it must be flushed before using.

**NOTE:** Prior to striping, see Linestripping Operations for correct gun arm set up, to get proper sized lines.

# STARTING UP

## 1. Learn the controls.

**Pressure Control Knob** - Used to adjust pressure only. Turn clockwise to increase pressure and counterclockwise to decrease pressure. (See Fig. 6)

**Prime & Pressure Relief Valve** - Turn to OPEN position (see Fig. 7) to prime the pump. Turn to the CLOSED position to spray.

### FOLLOW THE "PRESSURE RELIEF PROCEDURES" ON PAGE 11 WHENEVER YOU:

- are instructed to relieve pressure
- stop spraying
- checking or servicing any of the system equipment.
- **install or clean the spray tip.**

### HANDLE THE SPRAY SYSTEM AS YOU WOULD A LOADED FIREARM!!

#### **CAUTION**

*Do not start engine without fluid pump having enough fluid so that it can be primed. Running fluid pump dry will decrease life of the pumps packings.*

## 2. Prepare the Material

- Prepare the material according to the manufacturer's material recommendations.
- Place the pump or suction tube into the material container.

## 3. Starting the Sprayer (see Fig. 6 & 7 above)

- Prime Valve must be open to the priming position.
- Pressure Control Knob must be in the low pressure position.
- Follow the procedure under "How to Flush", page 7, Steps 6 through 12.

#### **WARNING**

*To stop the unit in an emergency or before performing any service or maintenance procedure follow the Pressure Relief Procedure on page 11 to relieve the fluid pressure.*

**FIGURE 6**

**PRESSURE CONTROL KNOB**



**FIGURE 7**

**Closed (Pressure)**

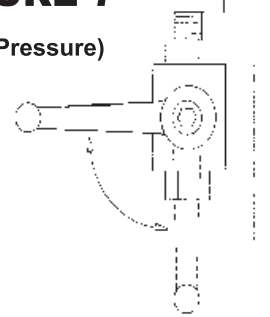

## 4. Prime the Pump

- Allow pump to operate until paint comes from gun.
- Release the trigger and engage the gun safety latch.
- Turn Prime Valve OPEN to the prime position ensuring the pressure is released from the system.
- Turn Pressure Control Knob to minimum pressure.
- Install spray tip onto gun.
- Close the prime valve to the pressure position.
- Turn the pressure control knob to desired spray pressure.
- Disengage the gun safety lock and you are ready to start spraying.

#### **WARNING**

*If you spray into the paint bucket, always use the lowest spray pressure and maintain firm metal to metal contact between gun and container. See page 7, Fig. 4.*

## 5. Adjusting the Pressure

- Turn the Pressure Control Knob clockwise to increase pressure and counterclockwise to decrease pressure.
- Always use the lowest pressure necessary to completely atomize the material.

#### **CAUTION**

*Operating the sprayer at higher pressure than needed wastes material, causes early tip wear and shortens sprayer life.*

- If more coverage is needed use a larger tip rather than increasing the pressure.
- Check the spray pattern. The tip size and angle determines the pattern width and flow rate.

# STARTING UP

## 6. Cleaning a Clogged Tip.

### WARNING

*Always follow the Pressure Relief Procedure before performing any service or maintenance procedure.*

### WARNING

*Never hold your body, fingers, or hand in front of the spray tip when cleaning or checking it for a cleared tip. Always point the gun forward or into a waste container when checking to see if the tip is cleared or when using a self-cleaning tip.*

- a. Follow the Pressure Relief Procedure.
- b. Clean the front of the tip frequently (with a toothbrush only) during the day to keep material from building up and clogging the tip.
- c. To clean and clear a tip if it clogs, refer to the separate instruction manual received with your gun and nozzle.

### **There is an easy way to keep the outside of the tip clean from material build-up:**

Everytime you stop spraying, for even a minute, lock the gun and submerge the gun nozzle into a small bucket of thinner compatible with the material sprayed.

Thinner will dissolve the build up of paint on the outside of the tip, tip guard and gun much more effectively than if the paint dries out completely.

### WARNING

*With a Clogged standard flat tip - clean only after the tip is removed from the gun. Follow the Pressure Relief Procedure*

## 7. When shutting Off the Sprayer

- a. Whenever you stop spraying, even for a short break, follow the Pressure Relief Procedure.
- b. Clean the tip and gun as recommended by your separate gun instruction manual.
- c. Flush the sprayer at the end of each work day if the material you are spraying is waterbased, or if it could harden in the sprayer overnight. See "Flushing" page 6 and 7. Use a compatible solvent to flush, then fill the pump and hoses with an oil based solvent such as mineral spirits.
- d. For long term shutdown or storage, refer to page 6.

# DAILY MAINTENANCE

1. Always stop the pump at the bottom of its stroke when you take a break or at the end of the day. This helps keep material from drying on the rod and damaging the packings.
2. Keep the displacement pump packing nut/wet cup lubricated with TSO (Airlessco Throat Seal Oil) at all times. TSO helps protect the packings and rod.
3. **Inspect the packing nut daily.** Your Airlessco pump has a patented "Triple Life Packing System". **Packing life will be extended a minimum of 3**

### **times if the following Packing Adjustment Procedure is followed:**

Inspect the packing nut daily. If seepage of paint is going into the packing nut and/or movement of the piston upward is found (while not spraying), the packing nut should be tightened enough to stop leakage only, but not any tighter.

**Overtightening will damage the packings** and reduce the packing life to the life of other piston pumps.

4. Lubricate Connecting Rod Pin every 3 months with SAE 30 W oil or annually with bearing grease.

# PRESSURE RELIEF PROCEDURE

To avoid possible serious bodily injury, including injection, always follow this procedure whenever the sprayer is shut off, when checking or servicing it, when installing or changing the tips, whenever you stop spraying or when you are instructed to relieve the pressure.

1. Engage gun safety latch. Refer to separate instruction manual provided with your gun on its safety features and how to engage safety latch.

2. Turn engine off.



3. Disengage safety latch & trigger gun to relieve residual fluid pressure. Hold metal part of the gun in contact with grounded metal pail.

4. Re-engage gun safety latch

5. Turn Prime/Pressure Relief Valve as shown open (priming) to relieve fluid pressure.

\* Leave prime valve OPEN until you are ready to spray again.



## IF THE SPRAY TIP OR HOSE IS CLOGGED:

Follow Step 1 through 5 above. Expect paint splashing into the bucket while relieving pressure during Step 5. If you suspect that pressure hasn't been relieved due to damaged prime/pressure relief valve or other reason, engage gun safety latch and take your sprayer to an authorized Airlessco Service Center for service. \*Always follow recommended pressure & operating instructions.

## HOSES

Tighten all fluid connections securely before each use. High pressure fluid can dislodge a loose coupling or allow high pressure spray to be emitted from the coupling and result in an injection injury or serious bodily injury.

Use only a hose that has a spring guard. The spring guard helps protect the hose from kinks or other damage which could result in hose rupture and cause an injection injury.

NEVER use a damaged hose which can result in hose failure or rupture and cause an injection injury or other serious bodily injury or bodily damage. Before each use, check entire hose for cuts, leaks, abrasions or bulging of cover, or damage or movement of couplings. If any of these conditions exist, replace the hose immediately. Never use tape or any device to try to mend the hose as it cannot contain the high pressure fluid. NEVER ATTEMPT TO RECOUP THE HOSE. High pressure hoses are not recoupable. Help prevent damage to the hose by handling and routing carefully. Do not move the sprayer by pulling it with the hose.

# LINE STRIPING OPERATION

## 1. Choose handle location.

The choices are, installing the handle opposite of the single wheel assembly (standard set up) or placing the handle directly over the single wheel assembly. The handle location is really a matter of personal preference, however having the handle away from the single wheel assembly allows for easier loading/unloading from a van or truck.

## 2. Choose the gun arm position.

There are six holes in the frame for mounting the gun arm. In a standard set up (handle away from the single wheel assembly), the gun arm would be mounted in one of the two mounting holes near the single wheel. This allows for an easier visual check for straight line striping and for basic arc striping. Regardless of the handle position, use the center mounting holes, near the axle, for precise circles and arcs. The mounting holes under the handle are usually used when the handle has been placed over the single wheel. Experiment with different combinations to find the set up that you prefer.

## 3. Setting up the guns.

- Ensure that striping tips are in the guns.
- Pick a tip size for the desired line width.  
**Example:** a 217ST tip for a four inch line.
- Place gun into the gun holder, so that the top of the taper on the gun handle is flush with the edge of the gun holder.
- Set gun height for the desired line width. Adjust height by loosening the small black handle on the gun holder assembly and slide the gun arm to the correct height. Now tighten the handle. This will require some experimentation to find the correct height. It is suggested that tape, or some other method is used to mark the height of commonly used settings.
- Set spacing between the two guns by loosening the black handle on the gun arm. Slide to the desired width and tighten.
- Attach the swivel heads to the guns if painting curbs or wide stripes.
- Angle the guns slightly forward. This allows the spray pressure from the guns to help blow dirt and debris out of the path of the new stripes.

## 4. Cable Tension Adjustment.

Once the handle and gun arm assemblies are set up to the preferred positions, pressurize the unit and trigger each gun to ensure that they activate and release correctly. If not, adjust the cable tension as follows:

- Locate the adjustment knobs on the base of the gun trigger, where the cable connects to the gun trigger assembly.
- Loose the locking nut and move the adjusting screw until the slack has been removed from the cable.

- Tighten locking nut and retest gun triggers for proper function.

**Note:** *There is an additional cable adjustment where the cable attaches to the gun holder assembly. Use only if the gun trigger adjustment is insufficient.*

## 5. Align caster wheel assembly.

### STRAIGHT LINES

- Loosen the two ratchet handles on the caster wheel assembly, just enough to be able to move the assembly by hand. Lift the ratchet handle to move the handle without turning the attached bolts, then press down and turn handle counterclockwise to loosen.
  - Place the turnbuckle over the two mounting nubs on the frame.
  - Pressurize the unit with water and Airlessco's Pump Conditioner and spray out several lines with the caster assembly in the locked position. Use the turnbuckle to fine tune the alignment of the wheels, until the stripes are straight.
-  **IMPORTANT:** Loosen ratchet handles prior to any turnbuckle adjustment.
- Tighten the jam nuts on the turnbuckle to affix the turnbuckle length for future reference.
  - Tighten the ratchet handles.

### CURVES AND ARCS

Basically the same as above, except the caster wheel assembly is set at angle. The caster assembly can be adjusted to 30 degrees either side of straight ahead. If you have arcs that you paint regularly, purchase additional turnbuckles (PN. 136-163) and keep them set to those arc sizes.

## 6. Miscellaneous Operations.

- CURBS:** Adjust gun to desired height and turn swivel head towards curb.
- WIDE STRIPES:** Install wider fan striping tips and raise the gun height to achieve the desired width line. Also angle guns slightly towards each other to get an even coat of paint.
- STENCILS:** Install standard spray tip on the outer gun. Remove this gun from the gun holder and spray out the stencils.
- STANDARD PAINTING:** Same as stencils, but use additional paint hose as required.

## 7. Loading and Unloading.

Loading and unloading can be accomplished by one person, when the machine is in the standard set up, by rotating the caster wheel assembly all the way forward and leaning back on the handles. For taller vehicles, an Easy Load System is available use (part number 305-172). This wheel assembly attaches to the handles, allowing the machine to rock farther back, thus lifting the caster wheels much higher.

# AIRLESS SPRAY GUN OPERATION

## SPRAY GUN

Attach spray gun to airless unit and tighten fittings securely. Set the gun safety latch. (Also may be called gun safety lock, or trigger lock)

\* The gun safety latch should always be set when the gun is not being triggered.

Read all warnings and safety precautions supplied with the spray gun and in product manual.

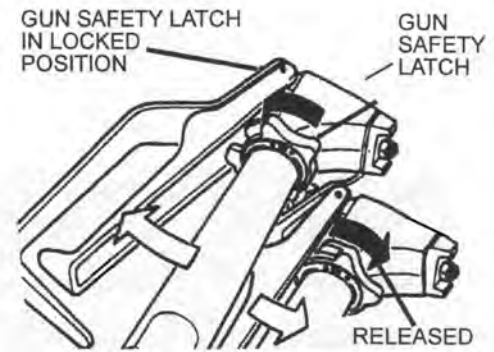

## MAJOR COMPONENTS OF SPRAY GUN & REVERSIBLE REV-TIP™

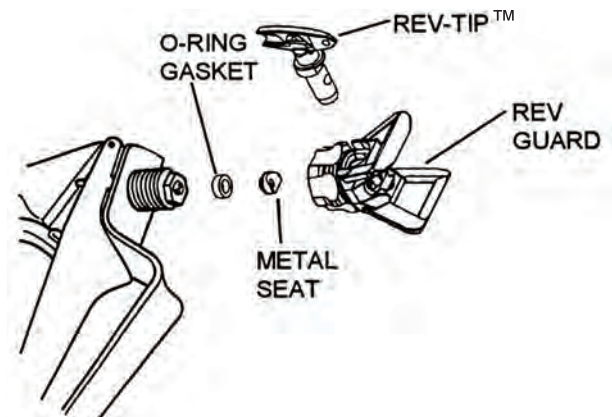
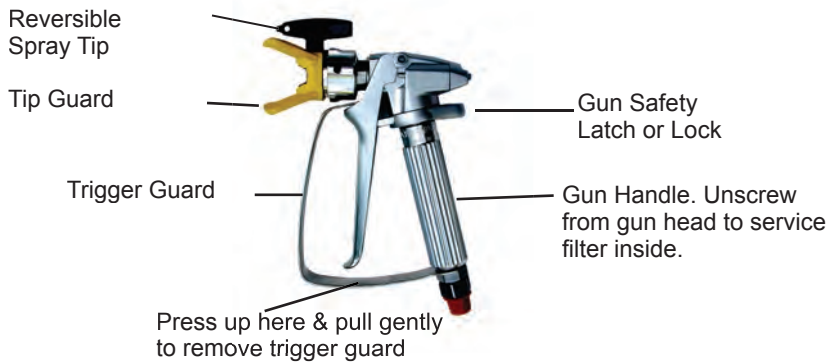

## SPRAY TIP ASSEMBLY

1. Be sure the pressure relief procedure is followed before assembling tip and housing to the gun.
2. Insert REV-TIP™ cylinder into the REV-GUARD™ (guard housing assembly).
3. Guide the metal seat into REV-GUARD™ (guard housing assembly) through the retaining nut and turn until it seats against the cylinder.
4. Insert the O-Ring gasket onto the metal seat so that it fits into the grooves.
5. Finger tighten REV-GUARD™ retaining nut onto the gun.
6. Turn guard in the desired position.
7. Completely tighten the retaining nut.

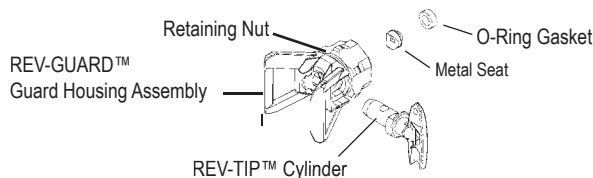

## TO REMOVE CLOGS FROM SPRAY TIP

1. Lock gun safety latch.
2. Turn REV-TIP™ handle 180 degrees.
3. Disengage trigger lock and trigger gun into the pail.
4. If the REV-TIP™ handle appears locked (resists turning), loosen the retaining nut. The handle will now turn easily.
5. Engage gun safety latch and return handle to the spray position.

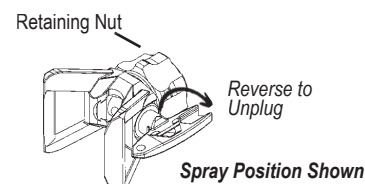

## CLEANING SPRAY GUN

Immediately after the work is finished, flush the gun out with a solvent. Brush pins with solvent and oil them lightly so they will not collect dried paint.

## CLEANING FILTER IN GUN HANDLE

To clean the filter, use a brush dipped in an appropriate solvent. Change or clean filters at least once a day. Some types of latex may require a filter change after four hours of operation.

## CLOGGED FLAT TIP

Should the spray tip become clogged, relieve pressure from hose by following the "Pressure Relief Procedure." Secure gun with the safety latch, take off guard, take out the tip, soak in appropriate solvent & clean with a brush. (Do not use a needle or sharp pointed instrument to clean the tip. The tungsten carbide is brittle and can chip.)

# AIRLESS SPRAY GUN TROUBLESHOOTING

<b>DEFECTS</b>	<b>CAUSE</b>	<b>CORRECTION</b>
Coarse spray	Low pressure	Increase the pressure.
Excessive fogging (overspray)	High pressure Material too thin	Reduce the pressure to satisfactory pattern distribution. Use less thinner.
Pattern too wide	Spray angle too large	Use smaller spray angle tip.
Pattern too narrow	Spray angle too small	Use larger spray angle tip. (If coverage is OK, try tip in same nozzle group)
Too much material	Nozzle too large Material too thin Pressure too high	Use next smaller nozzle. Reduce pressure.
Too little material	Nozzle too small Material too thick	Use next larger nozzle.
Thin distribution in center of pattern "horns"	Worn tip Wrong tip	Change for new tip. Use nozzle with a narrow spray angle.
Thick skin on work	Material too viscous Application too heavy	Thin cautiously. Reduce pressure and/or use tip in next smaller nozzle group.
Coating fails to close & smooth over	Material too viscous	Thin cautiously.
Spray pattern irregular, deflected	Orifice clogged Tip damaged	Clean carefully. Replace with new tip.
Craters or pock marks, bubbles	Solvent balance	Use 1 to 3% "short" solvents & remainder "longsolvents". (This is most likely to happen of low on work with material viscosity, lacquers etc.)
Clogged screens	Debris in paint Coarse paint pigments Incompatible paint mixture & thinners.	Clean screen. Use coarse gun filter screen. Use coarser screen for larger orifice tips. If thinner was added, test to see if a drop on top of paint mixes or flattens out on the surface. If not, try different thinner in a fresh batch of paint.

## TEST THE PATTERN

Good, full



Spotty Pattern  
Increase Pressure.





# LINE STRIPING TIP CHART

**NOTE: Striping Tips should not be used for regular spraying.**

**Rev-Tip™ for Striping**  
**Part Number 562-xxxST**  
**TIP IDENTIFICATION:**

- 1st 3-digits identifies it as a **REV-TIP™** for airless line striping (Part Number 562-xxxST).
- 4th digit is the fan width - the number is half the fan width, e.g., 5 means a 10' fan.
- 5th and 6th digits are for the orifice size and is measured in thousandths of an inch, e.g., 17 = 0.017 inch.

The higher the number, the larger the tip.

<b>Rev-Tip™ for Striping</b>		<b>STRIPING TIP - ORIFICE SIZE (Inches)</b>											
<b>Fan Width (6" from surface)</b>													
<b>in</b>	<b>(mm)</b>	<b>.009</b>	<b>.011</b>	<b>.013</b>	<b>.015</b>	<b>.017</b>	<b>.019</b>	<b>.021</b>	<b>.023</b>	<b>.025</b>	<b>.027</b>	<b>.031</b>	<b>.035</b>
<b>1-2</b>	<b>25-51</b>			113ST	115ST	117ST	119ST						
<b>2-4</b>	<b>51-102</b>				215ST	217ST	219ST	221ST					
<b>4-6</b>	<b>102-152</b>				315ST	317ST	319ST	321ST	323ST				
<b>6-8</b>	<b>152-203</b>									625ST			
<b>Striping Paint</b>				Oil Base	Oil Base	Latex	Latex	Latex	Latex	Latex	Latex		

		<b>.009</b>	<b>.011</b>	<b>.013</b>	<b>.015</b>	<b>.017</b>	<b>.019</b>	<b>.021</b>	<b>.023</b>	<b>.025</b>	<b>.027</b>	<b>.031</b>	<b>.035</b>
<b>Water Flow Rate</b> (gpm) <small>(water @ 2000psi, 138 bar)</small>	(gpm)		.12	.18	.24	.31	.38	.47	.57	.67	.77	1.03	1.31
	(lpm)		.49	.69	.91	1.17	1.47	1.79	2.15	2.54	2.96	3.90	4.98
<b>Paint Flow Rate</b> (gpm) <small>(latex paint @ 2000psi, 138 bar/1.36 spec. gr.)</small>	(gpm)		.10	.15	.21	.27	.33	.40	.49	.58	.66	.88	1.12
	(lpm)		.38	.57	.79	1.02	1.25	1.51	1.85	2.20	2.50	3.33	4.24
<b>Pump Minimum Output*</b> (gpm) <small>*Pump will support tip worn to next larger size.</small>	(gpm)		.25	.25	.33	.40	.50	.60	.75	.88	1.0	1.25	1.5
	(lpm)		1.0	1.0	1.25	1.5	1.9	2.3	2.8	3.3	3.8	4.7	5.7

**TIP REPLACEMENT:**

During use, high pressure will cause the orifice to grow larger. This destroys the pattern or will leave tailing or two heavy lines on the outside of the pattern. **REPLACE SPRAY TIP FREQUENTLY!**

# OIL & LUBRICATION PROCEDURE

**FIGURE 8**

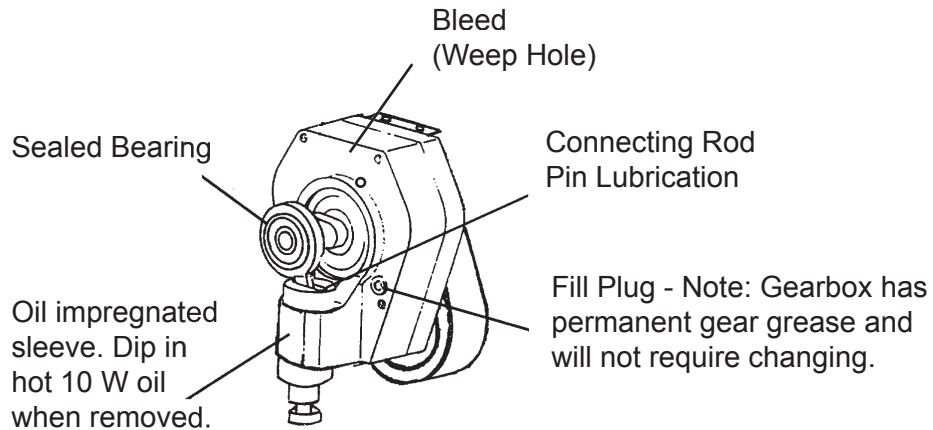

## TROUBLESHOOTING

<b>PROBLEM</b>	<b>CAUSE</b>	<b>SOLUTION</b>
There is spitting from the gun.	The fluid supply is low or empty. Air entrapped in the fluid pump or hose.	Refill the supply container. Check for loose connections on the siphon assembly, tighten, then reprime pump.
Paint leaks into the wet cup.	The packing nut/wet cup is loose. The upper packings are worn or damaged. Worn Piston Rod.	Tighten just enough to stop leakage. Replace the packings. See page 20. Replace Piston Rod
The engine operates, but the paint pump doesn't cycle.	The pressure setting is too low. The clutch is not engaged. The displacement pump is seized.	Increase the pressure. See page 9. See Troubleshooting "Clutch does not engage" page 22. Service the pump. See pgs. 17 & 18
The engine and displacement pump operates, but paint pressure is too low or none.	The pressure setting is too low. The tip or gun filter is clogged. The tip is worn. The fluid displacement pump filter is clogged. There is a large pressure drop in the fluid hose.	Increase the pressure, see page 9. Remove the tip and/or filter and clean them. Replace Tip. Clean the filter. Use a larger diameter hose.
The displacement pump operates, but the output is too low on the downstroke or both strokes.	The lower check valve ball is not seating properly.	Service the lower check valve see page 18.
The displacement pump operates, but the output is too low on the upstroke.	The upper check valve ball is not seating properly. The lower packings are worn or damaged.	Service the upper check valve per page 18. Replace the packings. See pages 19 & 20.
Clutch does not engage. Clutch slippage.		See Troubleshooting page 22. Call Authorized Service Center.
Engine stops		Refer to Engine Manual.

# SERVICING FLUID PUMP

**Note:** Check everything in the Troubleshooting Chart before disassembling the sprayer.

## **FLUID PUMP DISCONNECT**

1. Flush out the material you are spraying, if possible.
2. Follow the Pressure Relief Procedure on Page 11. Stop the pump in the middle of the down stroke.
3. Remove the suction tube and fluid hose (if so equipped) from the fluid pump.
4. Remove 2 retaining rings and slip the sleeve of the coupling down and remove both coupling halves. This will disconnect fluid pump from the connecting rod.
5. Unscrew the two tie rod locknuts.
6. Pull the pump off the tie rods.

## **FLUID PUMP REINSTALL**

1. Loosen the packing nut and extend piston rod to a full up position. Slip sleeve (189-047) over the piston rod.
2. Make sure that the spacer tubes (301-048) are in place.
3. Connect the connecting rod with the fluid pump by installing coupling halves (189-046). Slide sleeve over coupling halves. Secure with retaining ring (189-048).
4. Secure the fluid pump housing to the tie rods (100-328) and screw locknuts with washers on loosely.
5. Tighten the tie rod locknuts evenly to 30 ft. lb.
6. Reconnect fluid hose and suction tube (if so equipped).

**NOTE: After all the rod locknuts are tight, the alignment of both rods should allow easy assembly and disassembly of the coupling. If any binding, loosen and retighten all the rod locknuts to improve the alignment. Misalignment causes premature wear of seal and packings.**

7. Tighten the packing nut until there is resistance, then 1 full turn tighter. Approximately 4 threads will show when new packings are installed. Keep the wet cup of the packing nut lubricated with TSO.
8. Start the pump and operate it slowly (at low engine speed) to check the piston rod for binding. Adjust tie rod lock nuts if necessary to eliminate binding.
9. Run unit at maximum pressure for several minutes, then relieve pressure and repeat step 7.

# SERVICING UPPER & LOWER CHECK VALVES

## SUCTION VALVE (SEE FIG. 9 & 12)

1. Using the rod collar tool (189-211), unscrew the suction nut (187-018), containing suction seat support (187-017), off of the fluid body (187-313).
2. Remove the suction seat (187-065), O-ring (106-017), suction ball (187-020) and suction ball guide (187-016) with O-ring (106-014).
3. Clean all parts and inspect them for wear or damage, replacing parts as needed. Old O-rings should be replaced with new ones.

*\* NOTE: Suction seat (187-065) is reversible.*

## PISTON, OUTLET VALVE (SEE FIG. 10)

1. Place piston holder (187-248) in a vise. Slide the piston into the holder & lock in place with the 1/4" dowel.
2. Use a 3/8" allen wrench to unscrew the outlet seat support (187-051) from the piston (187-330).
3. Remove the outlet seat (187-061), O-ring (106-021), outlet ball (115-022) and ball guide (187-062).
4. Inspect the outlet ball and seat for wear. Replace as required.

*\*Note: Outlet seat (187-061) is reversible.*

5. While piston is still locked in the holder, install parts back into the piston in the following order: ball guide, ball, O-ring, outlet seat. Before reinstalling the outlet seat support apply two drops of Loctite No. 242 (blue) on the threads and torque to 20 ft-lbs.

**FIGURE 9**

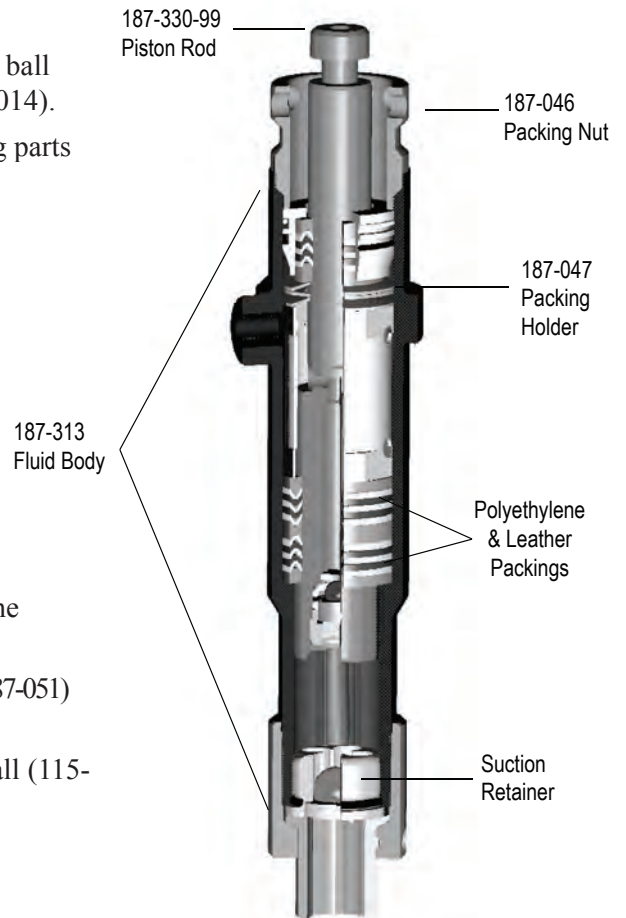

**FIGURE 10**



# PACKING REPLACEMENT

## Replacement Instructions (part number 187-040) & Tool Kit (part number 188-396)

### REFER TO FIGURE 9

#### Remove the Fluid Pump

1. Flush out the material you are spraying, if possible.
2. Follow the Pressure Relief Procedure on page 6t. Stop the pump in the middle of down stroke.
3. Remove the suction tube and fluid hose (if so equipped) from the fluid pump.
4. Remove the connecting rod shield from the pump.
5. Remove 2 retaining rings and slip the sleeve of the coupling down and remove both coupling halves. This will disconnect fluid pump from the connecting rod.
6. Using a 7/8" box wrench, disconnect the high pressure fluid line from the pump.
7. Using a 9/16" wrench, unscrew the two tie rod locknuts.
8. Pull the pump off the tie rods.

#### Remove the Suction Valve

1. Using the rod collar tool (189-211), unscrew the suction nut (187-018), containing suction seat support (187-017), off of the fluid body (187-313).
2. Remove the suction seat (187-065), O-ring (106-017), suction ball (187-020) and suction ball guide (187-016) with O-ring (106-014).
3. Clean all parts and inspect them for wear or damage, replacing parts as needed. Old O-rings should be replaced with new ones.

**\* NOTE: Suction seat (187-065) is reversible.**

#### DISASSEMBLY OF THE FLUID PUMP

1. Unscrew & remove the packing nut (187-046).
2. Push the piston rod (187-330-99) down through the packings & out of the pump.
3. Now push the packing removal tool (187-249) up through the pump & remove from the top bringing the packings, spacer & springs along with it, leaving the fluid body (187-313) empty.

**\*Make sure all packings & glands have been removed from the fluid pump.**

4. Clean inside of fluid body (187-313).
5. Disassemble all parts & clean for reassembly. Discard any old packings. **Save the metal upper glands (187-026 & 187-025).** Replace metal lower glands (187-037) with new metal glands from the packing kit.

**\* Note: If the old packing had a metal gland for (187-058), discard & replace with a new plastic one from the packing kit.**

6. Lubricate leather packing in lightweight oil for 10 minutes prior to reassembly.

#### DISASSEMBLY OF THE OUTLET VALVE REFER TO FIGURE 10





1. Place piston holder (187-248) in a vise. Slide the piston into the holder & lock in place with the 1/4" dowel.
2. Use a 3/8" allen wrench to unscrew the outlet seat support (187-051) from the piston (187-330).
3. Remove the outlet seat (187-061), O-ring (106-021), outlet ball (115-022) and ball guide (187-062).
4. Inspect the outlet ball and seat for wear. Replace as required.

**\*Note: Outlet seat (187-061) is reversible.**







5. While piston is still locked in the holder, install parts back into the piston in the following order: ball guide, ball, O-ring, outlet seat. Before reinstalling the outlet seat support apply two drops of Loctite No. 242 (blue) on the threads and torque to 20 ft-lbs.

#### REASSEMBLY

##### Refer to Figure 11 & 12

1. Take the lower metal male gland (187-037) and place it down on the flat side. 
2. Take three of the lower polyethylene packings (187-029) and two of the leather packings (187-059) and place onto your male gland in the following order with the inverted side down :  polyethylene, leather, polyethylene, leather, polyethylene.
3. Take the female adaptor (187-058), which is inverted on both sides , and place it on top of your assembled lower packings.
4. Follow step 2 above but with packings inverted side up. 
5. Take the second lower male gland and place it on top of your assembled packings with the rounded side down. 
6. Take your assembled glands & packings (13 pieces all together) and slide on to the lower half of the piston.
7. Take the spacer (187-315) and slide over the top of the piston (it doesn't matter which direction it sits), falling onto the lower packings.

# PACKING REPLACEMENT

8. Take the three Belleville Springs (187-031) and slide over the top of the piston in the following order:
  - \* First spring, curve facing down 
  - \* Second spring, curve facing up 
  - \* Third spring, curve facing down 
9. Take the upper male gland (187-025) and place it with the rounded side up. 
10. Take the three upper polyethylene packings (187-030) and two leather packings (187-060) and assemble with the inverted side down , on to the male gland in the following order: polyethylene, leather, polyethylene, leather, polyethylene.
11. Take the upper female gland (187-026) & place on top of your assembled upper packings with the inverted side down. 
12. Take your assembled upper glands and packings (7 pieces) and slide on over the top of the piston, making sure the inverted sides are facing down.
13. Take the packing holder (187-047) and replace the white O-ring (106-012) and the black O-ring (106-013) with new ones from the packing kit.
14. Slide the packing holder over the top of the upper packings so they fit inside.
15. Lubricate the inside of the fluid pump body and the outside of the packings with a light weight oil.
16. Slide the completed assembly into the fluid pump body (187-313).
  - \* **To keep packings secured in the correct position, hold the pump body upside down and push the completed assembly upwards into the pump body. Once placed inside, tilt the pump body back up to keep all pieces in.**
17. Thread the packing nut (187-046) into the top of the fluid body and tighten hand tight.
18. Take the suction retainer (187-016) and replace the black O-ring (106-014) with a new one from the packing kit. Replace the suction ball (187-020) with the new one from the kit into the suction retainer. Place the suction seat (187-065) into the flat side of the ball guide, over the suction ball. Now place the white O-ring (106-017) into the groove around the suction seat.
19. Take the completed suction valve assembly and place it into the bottom of the fluid body, with the rounded side fitting inside.
20. Take the suction seat support (187-017) and place the flat side down on to the suction valve assembly (threads will be facing upwards).
21. Thread the suction nut (187-018), over the suction seat support.
22. Tighten the packing nut (utilizing the packing nut adjustment tool) clockwise one full turn.

**FIGURE 11**

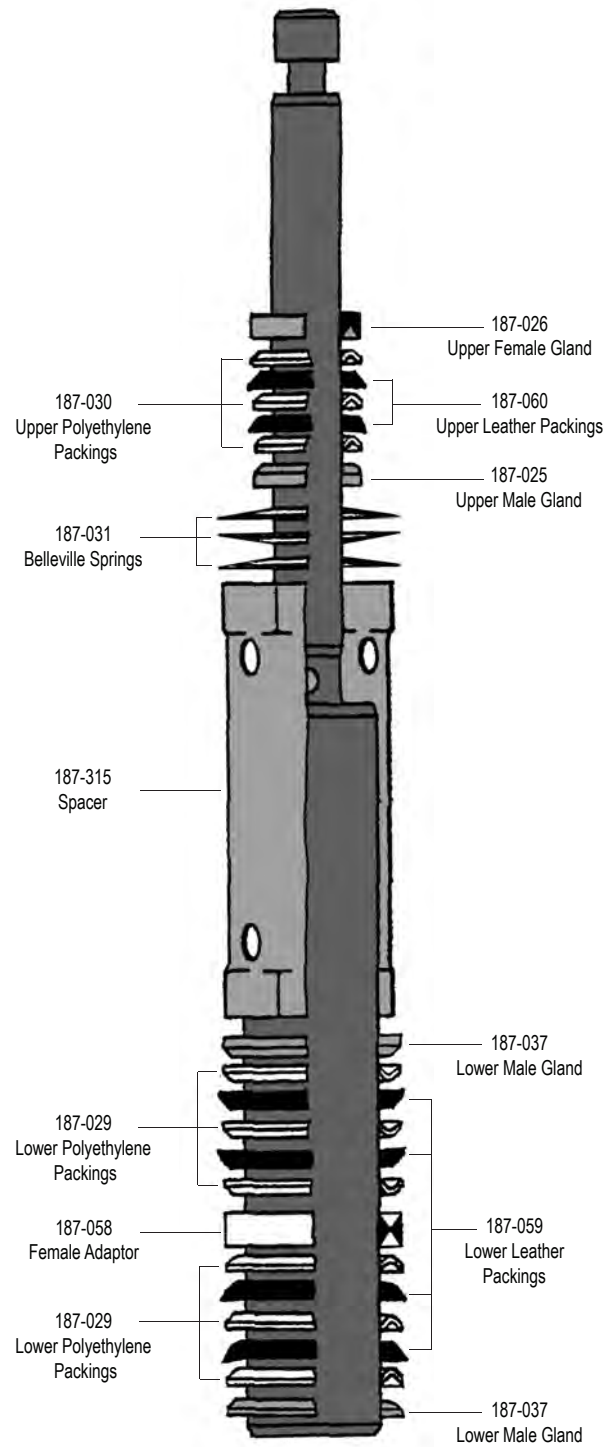

# PACKING REPLACEMENT

## FLUID PUMP REINSTALL

1. Loosen the packing nut and extend piston rod to fully up position. Slip sleeve (187-047) over the piston rod.
2. Make sure that the spacer tubes (301-048) are in place.
3. Connect the connecting rod with fluid the fluid pump by installing the coupling halves (189-046). Slide sleeve over the coupling halves and secure with retaining ring (189-048).
4. Secure the fluid pump housing to the tie rods (100-328) and screw locknuts with washers on loosely.
5. Tighten the tie rod locknuts evenly to 30 ft. lb.
6. Tighten the packing nut clockwise until resistance against the packings can be felt. Turn it one full turn more.
7. Start the pump and operate it slowly (at low engine speed) to check the piston rod for binding. Adjust tie rod lock nuts if necessary to eliminate binding.
8. Prime the unit and run at maximum pressure for several minutes, then release the pressure and repeat step 6.
9. Fill the wet cup (packing nut) about 1/3 full of TSO (Throat Seal Oil).

**NOTE:** After all the rod locknuts are tight, the alignment of both rods should allow easy assembly and disassembly of the coupling. If any binding, loosen and retighten all the rod locknuts to improve the alignment. Misalignment causes premature wear of seal and packings.

**FIGURE 12**

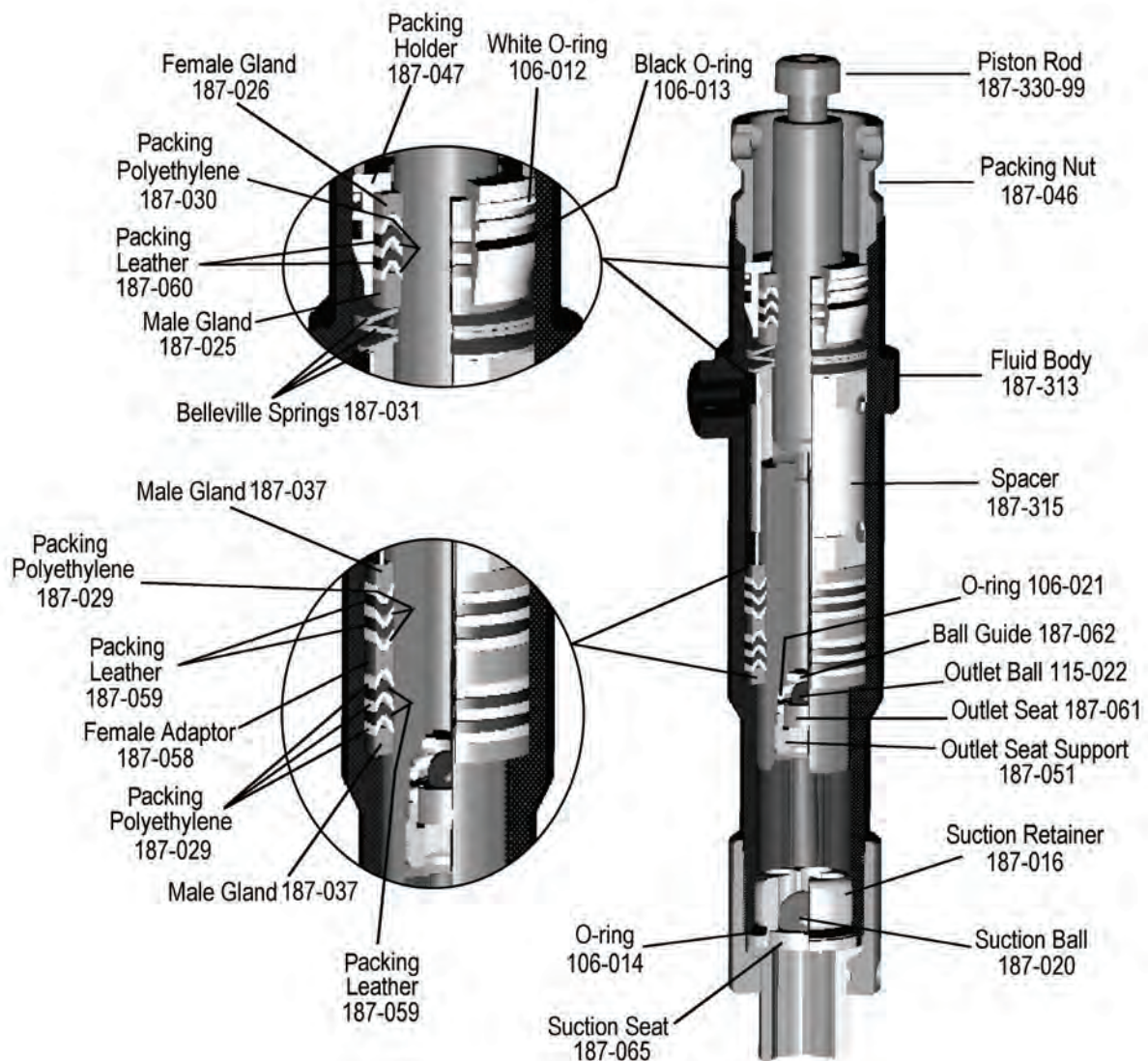

# BALL VALVE - Part Number 100-119

**FIGURE 13**

PARTS LIST - FIGURE 13		
ITEM NO.	PART NO.	DESCRIPTION
1	100-162	Handle
2	100-163	Screw
3	100-164	Ball
	KIT-119	Repair Kit

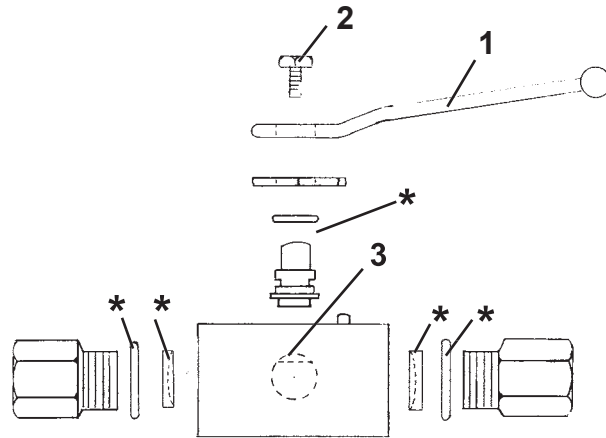

## TROUBLESHOOTING - CLUTCH DOES NOT ENGAGE

- STEP 1:** Ensure that the pressure control knob (POT) is in the maximum (CW) position.
- STEP 2:** Remove the upper and lower clutch and electrical covers.
- STEP 3:** Check all electrical connections between the engine magneto, sensor, control board and clutch for loose connections or damaged leads. See Fig. 14.
- STEP 4:** Disconnect the two leads from the control board (blue) and the clutch assembly (black). Using a multimeter, with the engine at maximum RPM, pressure control knob in the maximum position and the prime valve in the open (priming) position, test the DC voltage from the boards leads. This voltage must be 13-14 VDC. If the readings are correct, the board, sensor and magneto are okay and the problem is in the clutch assembly. If this is the case, proceed to Step 5. If the voltage is outside this range go to Step 7.
- STEP 5:** Measure resistance between the clutch leads (blue or black). This value must be 10-16 ohms. If this reading is out of specifications the clutch is defective and must be replaced, otherwise continue troubleshooting.
- STEP 6:** If the clutch resistance readings of Step 5 are correct, check the spacing between the clutch field and plate. The gap should be .012" to .024". If the gap is greater than .028" the gap is too wide. If this gap is too wide, remove spacer (Fig. 15 Item 4) from the clutch assembly. Should the clutch still not engage, replace the clutch assembly. See page 24 in manual.
- STEP 7:** When the DC voltage from the board is not 13-14 VDC, disconnect the control board lead (black) from the engine magneto lead (pink), located on the side of the engine. With the engine at maximum RPM, pressure control knob in maximum (CW) position and prime valve open (priming), read the AC voltage from the magneto lead to the sprayer frame. This reading should be 19-24 VAC. If outside this range, contact your local Honda repair facility for magneto replacement. If the magneto is producing the proper AC voltage, continue to Step 8.
- STEP 8:** Test the sensor by reading the resistance between the red and black wires. The resistance runs between 1.8- 3.5 kohms. A defective sensor usually shows no resistance (open). If the reading is outside standards, replace the sensor. An alternative method to test the sensor, is to plug a new sensor into the board and see if the clutch will engage.
- STEP 9:** When Steps 7 & 8 have been completed and the magneto and sensor check good, the electrical control board is the only item left, replace the board. See page 23.

### **CAUTION**

**When using this method, turn the machine off as soon as the clutch engages. This is important because the sensor plugged into the board is not measuring pressure in the fluid section. The machine can build extreme pressure if not immediately turned off.**



# REPLACEMENT ELECTRICAL CONTROL BOARD

1. Remove electrical cover.
2. Disconnect sensor lead from Electrical Board.
3. Disconnect two clutch leads on Electrical Board from leads on clutch.
4. Using a 1/16" allen wrench, loosen set screw in Pressure Control Knob and remove knob.
5. Using a 1/2" nut driver or 1/2" deep socket, remove nut from pressure control shaft. This will allow removal of electrical control board from frame.
6. Replace Electrical Board Assembly in reverse order. Adjust pressure as per procedure below, "Pressure Calibration on the Electrical Control Board".

## PRESSURE CALIBRATION - ELECTRICAL CONTROL BOARD

1. Turn "Pressure Calibration" Trimpot adjustment on electrical control board in the counter clockwise direction at least 15 revolutions.
2. Connect 5000 psi glycerine pressure gauge on output of pump between hose & gun to monitor fluid pump pressure. Test Gauge Assembly with 1/4" fittings (part number 111-045) is suggested.
3. Start engine and run at maximum RPM. Turn Prime/Pressure Relief Valve to the open (prime) position. Turn Pressure Control Knob to maximum position (fully clockwise).
4. Using an insulated screwdriver, adjust "Pressure Calibration" Trimpot by turning clockwise until the clutch engages. When the clutch engages the pump will commence priming. When pump is primed, turn the Prime/Pressure Relief Valve to the closed (pressure) position.
5. Trigger gun. The pressure should drop approximately 350-400 psi. The clutch will engage and build pressure to 3000 psi and disengage. Trigger gun several times to ensure proper pressure setting. Pressure drop is a function of hose size. It will be 350-450 psi with 50 ft. of 3/8" hose, but it will be larger if only 50' of 1/4" hose is used.
6. Turn Pressure Control Knob to minimum position. The clutch should disengage and pump will stop moving.
7. Secure leads with tie strap.
8. Replace cover on unit. Ensure the leads are not pinched or damaged in the process of replacing covers.

The pump will begin to pressurize and the clutch will disengage at a low pressure. Continue turning the Trimpot clockwise to increase pressure to 3000 psi.

**FIGURE 14**

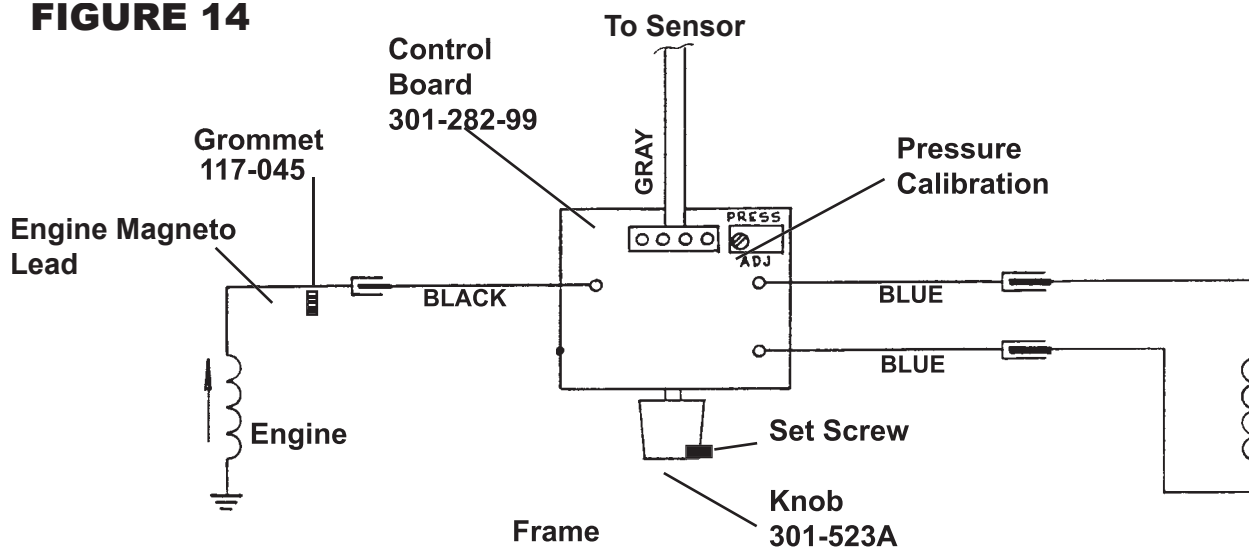

# CLUTCH REPLACEMENT

## REMOVE CLUTCH AS FOLLOWS:

1. Remove the upper and lower clutch covers.
2. Extract the splash cover from the clutch brackets and spacer tubes.
3. Disconnect the two clutch leads from the electrical control board leads.
4. Unscrew the whip hose from the manifold filter.
5. Remove the two nuts on the fluid section bracket and shock mounts.
6. Remove the four nuts from the gearbox (Fig. 28, Item 23) which pass through spacer tubes (Fig. 28, Item 15).
7. Pull the cog belt loose off the engine shaft cog pulley (Fig. 15, Item 2) and remove the gearbox/clutch assembly from the rest of the unit.
8. Place gearbox in vice by gripping the flat part of the drive crank allowing the clutch assembly to face up. Use caution and not allow gearbox to swing and damage casting against vice.
9. Hold coupling screw, with 13/16" wrench, then with 5/16" allen wrench, screw differential screw (Fig. 16, Item 1), out of coupling screw & gearbox shaft.
10. Screw large end of differential screw into coupling nut assembly (Fig. 16, Item 2) and pull out of clutch assembly.
11. The clutch (Fig. 16, Item 5) can now be removed. Fig. 16, Items 3-8 should be inspected for wear and replaced if needed.

## INSTALL NEW CLUTCH AS FOLLOWS:

1. With gearbox held as described above (Step 8), place first spacer (Fig. 16, Item 8) and bearing (Fig. 16, Item 6) onto gearbox shaft.
2. Insert snap rings (2), (Item 7) into recesses of cog pulley portion of clutch. Place cog pulley portion of clutch with cog belt attached onto shaft.
3. Place second spacer, (Item 8) into cog pulley portion of clutch. This spacer will rest on the first bearing (Item 6) installed.
4. Insert second bearing (Item 6), on top of upper snap ring (Item 7).
5. Lay removable spacer (Item 4) on top of last bearing. If the clutch air gap is larger than .028, do not use removable spacer. Put spacer (Item 3) over removable spacer, (if used) and top bearing.
6. Place coil portion of clutch down onto cog pulley portion of clutch and center on gearbox shaft.
7. Screw differential screw (Item 1) into coupling screw and nut, until 1/16" is showing. (See Fig. 17)
8. Push coupling nut assembly (Item 9) into clutch assembly until it comes to a positive stop. (Differential screw comes into contact with the threaded gearbox shaft.)

## INSTALL NEW CLUTCH CONTINUED.....

9. With 13/16" wrench on coupling screw and 5/16" allen wrench in differential screw, simultaneously screw coupling nut assembly into gearbox shaft by turning clockwise until a positive stop is reached.
10. Hold coupling nut ass'y and tighten differential screw to 30 ft.-lbs. This will expand the coupling assembly, thereby holding the clutch assembly to gearbox shaft. Turn clutch observing clutch gap. The pulley should turn freely with a gap of .012" to .024" between the two clutch faces. If the gap is greater than .028" remove spacer. Reassemble and check gap for proper clearance.
11. Reinstall the gearbox/clutch assembly, by placing the fluid section bracket over the shock mount bolts.
12. Slip cog belt over the engine shaft cog pulley.
13. Re-assemble four studs, spacer tubes and nuts as before. Slightly loosen four screws (Fig. 14, Item 5).
14. Tighten set screws (Fig. 14, Item 6) until cog belt is properly tensioned, then tighten four screws (Item 5).
15. Tighten the shock mount nuts.
16. Reattach the whip hose to the manifold filter.
17. Connect the clutch and board leads.
18. Replace the splash shield.
19. Test the clutch for proper operation.
20. Replace clutch covers.

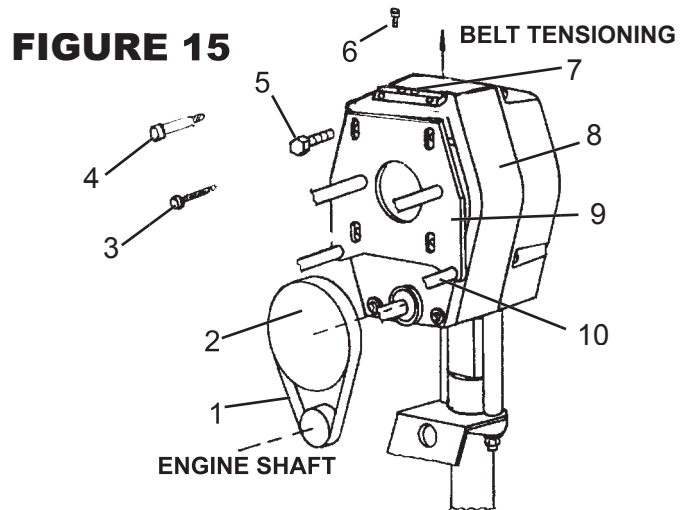
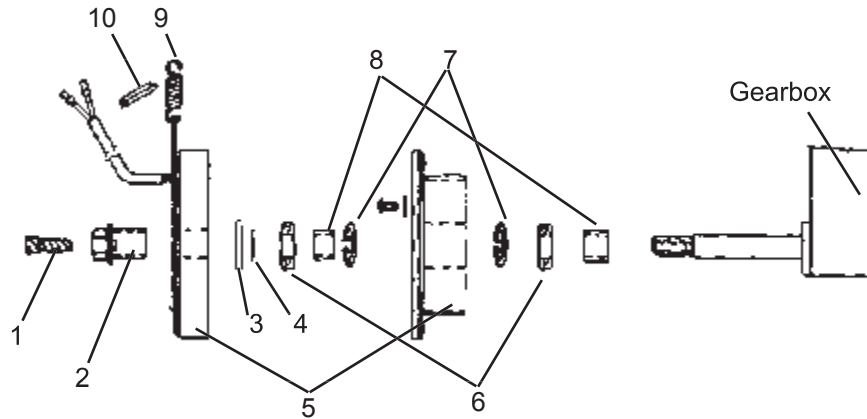

**FIGURE 15**

FIGURE 15 PARTS LIST		
ITEM NO.	PART NO.	DESCRIPTION
1	301-231	Cog Belt
2	301-284	Clutch Replacement
3	305-088	Screw
4	100-175	Shoulder Screw
5	100-173	Screw Flanged (4)
6	100-174	Set Screw (2)
7	301-534	Block Tensioner
8	301-207-99	Gearbox
9	305-045	Plate
10	305-046	Spacer Tube (4)

# CLUTCH REPLACEMENT Part Number 301-284-99

**FIGURE 16**



Item No.	Part No.	Description	Item No.	Part No.	Description
1	112-041	Screw Differential	6	301-037	Bearing
2	112-054	Coupling Nut Assy	7	100-333	Retaining Ring
3	301-412	Spacer	8	301-274	Spacer
4	301-413	Spacer - Removable	9	136-068	Spring
5	301-284-99	Clutch Replacement	10	301-316	Rubber Edge

**FIGURE 17**

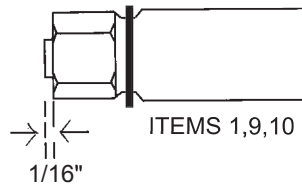

# ENGINE SHEAVE ASSEMBLY

**FIGURE 18**

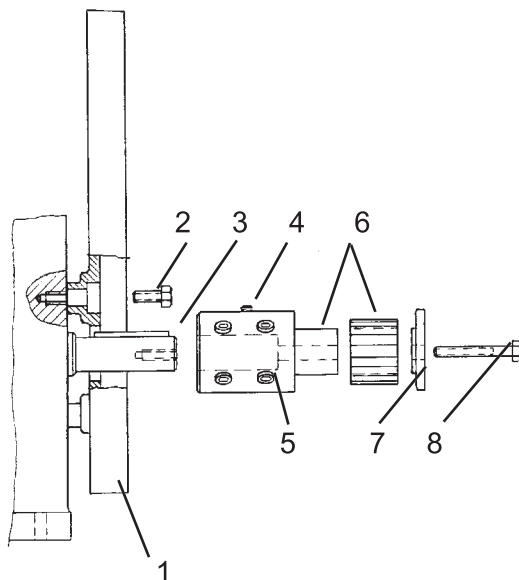

ITEM NO.	PART NO.	DESCRIPTION
1	305-012	Adaptor
2	100-392	Screw (4)
3	112-029	Key
4	100-357	Screw
5	100-383	Screw (4)
6	301-222A	Sheave
7	301-229	Thrust Plate
8	301-230	Screw

# MANIFOLD FILTER

Part Number 111-200-99

FIGURE 19

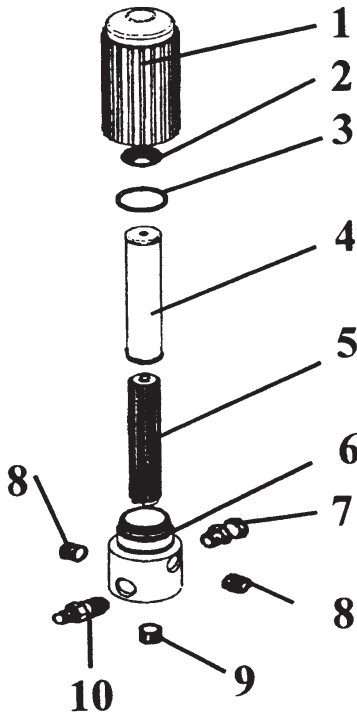

FIGURE 19 PARTS LIST		
ITEM	PART NO.	DESCRIPTION
1	111-202	Base*
2	301-356	Spring*
3	106-007	O-Ring*
4	111-204	Filter
5	111-203	Support*
6	111-201	Base*
7	100-101	Swivel
8	100-129	Plug 3/8" (2)
9	100-028	Plug 1/4"
10	100-109	Nipple 3/8 x 1/4
*	111-200	Filter

# SUCTION ASSEMBLY

Part Number 301-090-99

FIGURE 20

FIGURE 20 PARTS LIST		
ITEM NO.	PART NO.	DESCRIPTION
*	301-517	Suction Hose Ass'y (includes items 1-5)
1	141-008	Inlet Strainer
2	301-514	Suction Tube
3	301-516	Hose Clamps (2)
4	301-513A	Hose
5	100-165	Elbow
6	188-377	Return Pipe
7	100-128	Elbow
8	100-012	Whip
9	100-126	Elbow **
10	100-385	Reducer**

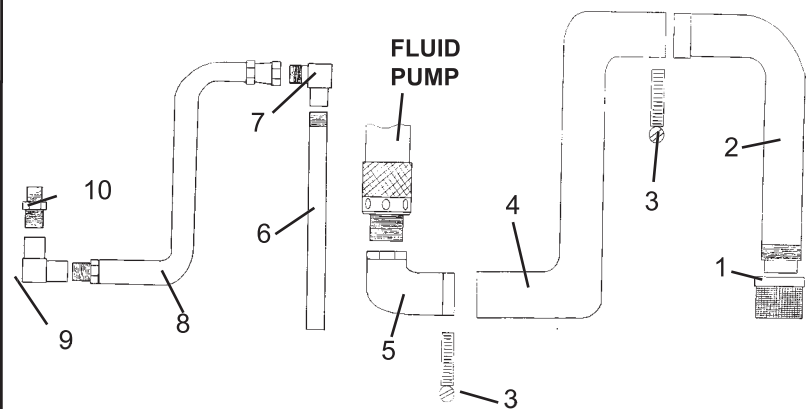

\*\* Used on units equipped with either the 100-180 or 331-050 prime valves. The 301-090 suction ass'y also includes the 100-081A Elbow for units with the 138-001 marathon prime valve.

# FIELD STRIPE PRO

**FIGURE 21**

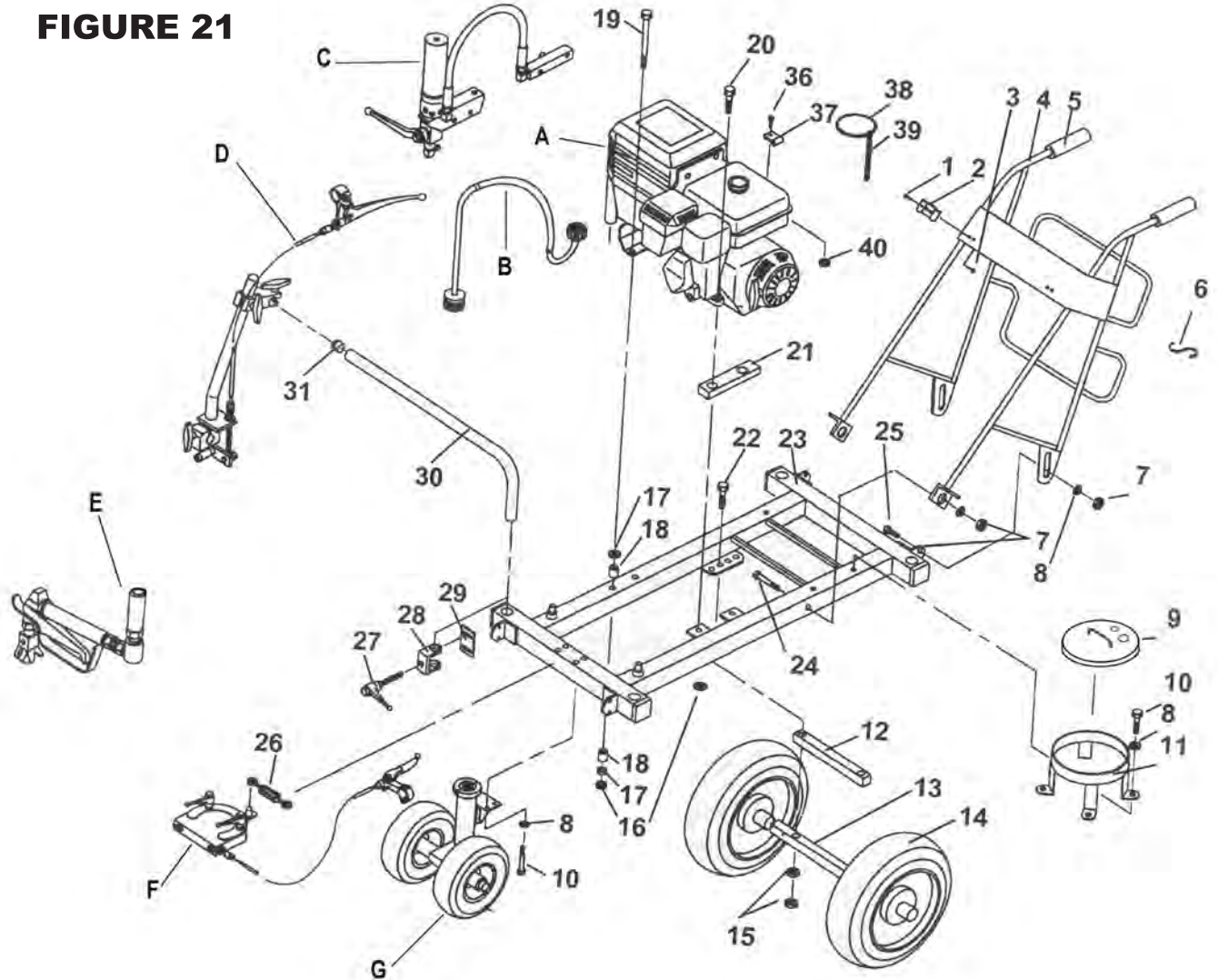

ITEM NO.	PART NO.	DESCRIPTION	ITEM NO.	PART NO.	DESCRIPTION
1	331-342*	Screw (2)	22	100-321	Screw (2)
2	331-138*	Clamp- Cable	23	305-195	Frame
3	120-021*	Lock Nut (2)	24	100-172	Screw (2)
4	305-057*	Handle Weldment	25	111-044	Screw (2)
5	305-058*	Rubber Grip (2)	26	136-163	Turnbuckle
6	331-135*	Spring Clip	27	305-044	Adjustable Handle
7	113-022	Nut (6)	28	305-051 M	Clamp
8	140-029	Washer (12)	29	305-108	Plate
9	301-533	Bucket Lid	30	305-076	Arm
10	111-044	Screw (8)	31	143-027	Ball guide
11	305-144	Bucket Holder	36	136-123	Screw
12	305-163	Spacer Bar	37	136-197	Terminal Ring
13	305-052	Axle	38	136-133	King Ring
14	305-056	Wheel (2)	39	136-131	Chain Sash
15	140-051	Nut (4)	40	100-317	Nut
16	100-317	Nut (2)	A	301-530	Drive & Clutch Assy
17	100-344	Washer (4)	B	301-517	Suction Assy
18	301-536	Shock Mount (4)	C	305-065	Paint System w/Filter
19	173-005	Screw (2)	D	305-150	Gun Holder Assy
20	136-123	Screw (2)	E	305-167-99	1st Gun Assy
21	301-535	Rubber Pad	F	305-030	Lock Assy
			G	305-022	Swivel Assy

# GUN ASSEMBLY Part Number 305-355

**FIGURE 22**

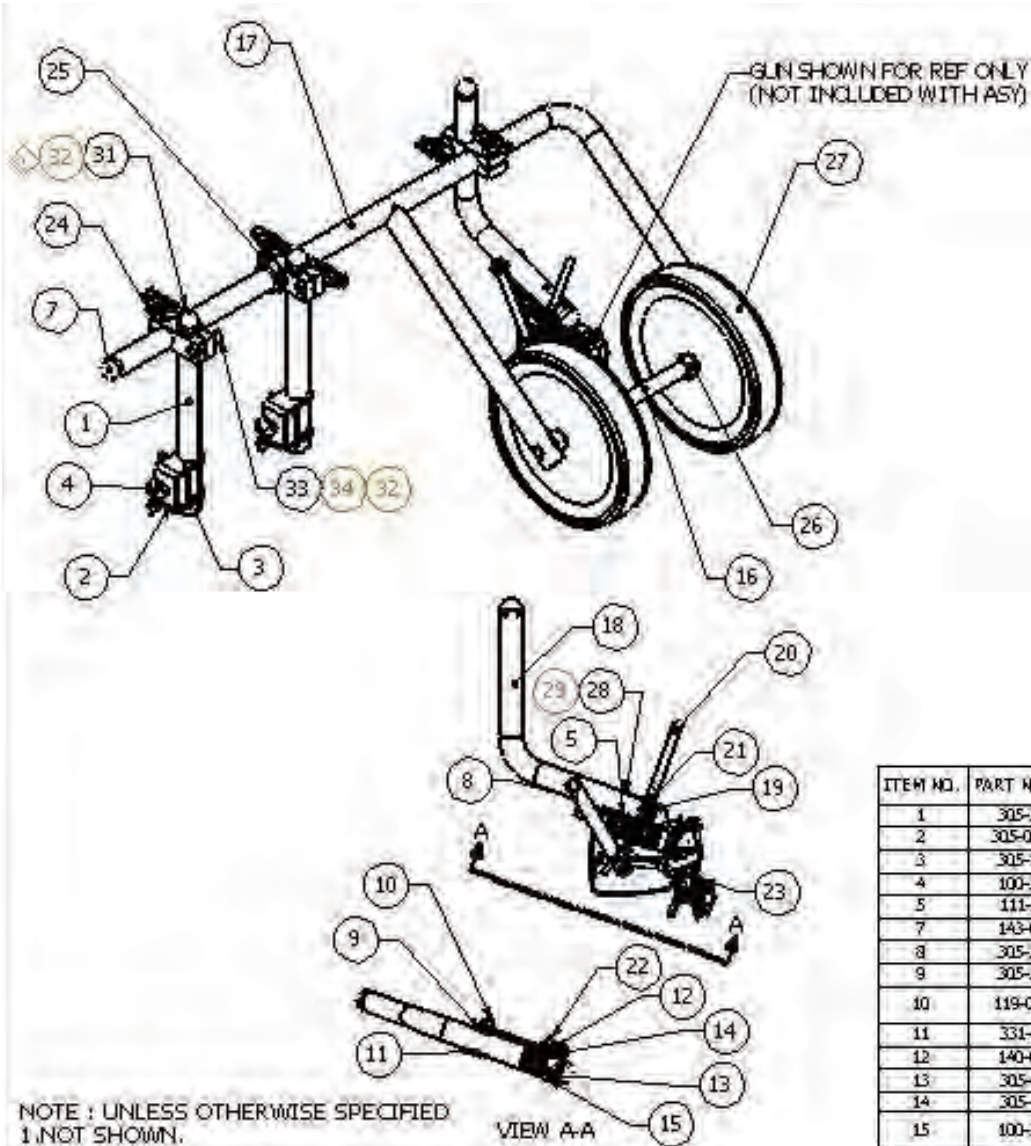

ITEM NO.	PART NUMBER	DESCRIPTION	QTY
1	305-292	SUPPORT TUBE	2
2	305-051M	CLAMP	2
3	305-308	PLATE, CLAMP	2
4	100-320	WING SCREW, 3/8	2
5	111-036	SPRING CLIP	1
7	143-027	BALL GUIDE	5
8	305-274	LEVER, TRIGGER	1
9	305-273	SPACER, .250	2
10	119-049R	SCREW, HEX HD, 290-20UNC-2A X 1.88 LG.	1
11	331-103	WASHER, FLAT, 1/4	3
12	140-045	NUT, JAM, .250	2
13	305-159	SLEEVE BEARING	2
14	305-161	SPACER	1
15	100-342	SCREW, SHLD, SOC HD, 3/12 X 1.250 LG.	1
16	305-351	AXEL, 5/8 X 14.50 LG.	1
17	305-356	MOUNTING TUBE	1
18	305-243	TUBE, GUN HOLDER	1
19	305-141	ADJUSTOR, CABLE	1
20	305-077	ASY, CABLE	1
21	305-089	SLEEVE, CABLE	1
22	305-079	ASY, WIRE SWIVEL	1
23	116-100	SPRINGS, COMPRESSION	1
24	136-019	SWIVEL BLOCK ASY	3
25	136-039R	SET COLLAR, 1.00	1
26	143-029	SET COLLAR 5/8 ID	4
27	305-367	WHEEL 10 X 1.75	2
28	119-050R	SCREW, PAN HD, #6-32UNC X 1.12	3
29	119-052	NUT, HEX, LOCK, #6-32UNC	3
30	305-142	LEVER, HAND	1
31	136-039	SET COLLAR	1
32	171-008	SCREW 3/8-16 X 1.75	2
33	140-051	NUT 3/8-16	1
34	189-378	SPACER, .71X.40 X .75	1

**FIGURE 24**

ITEM	PART NO.	DESCRIPTION
1	139-351	Roll Pin
2	305-184	Cam
3	305-183	Shaft
4	305-182	Bushing
5	140-034	Washer
6	140-051	Nut
7	305-044	Handle
8	305-108	Plate
9	305-181	Clamp
10	188-125	Screw

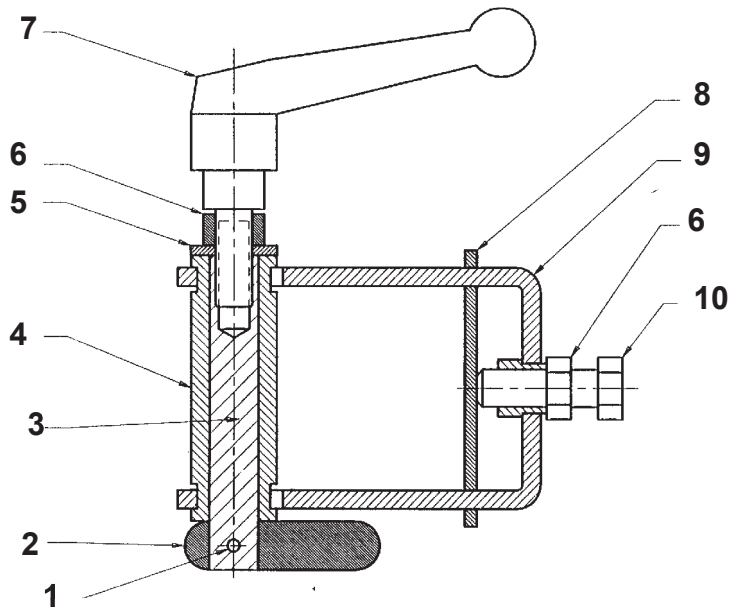

# LOCK ASSEMBLY Part Number 305-030

**FIGURE 26**

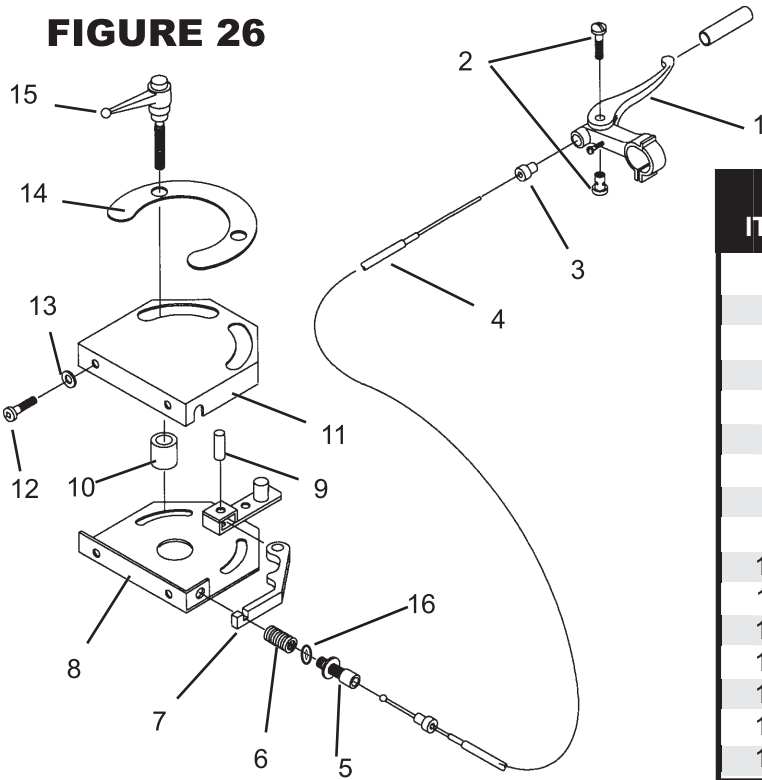
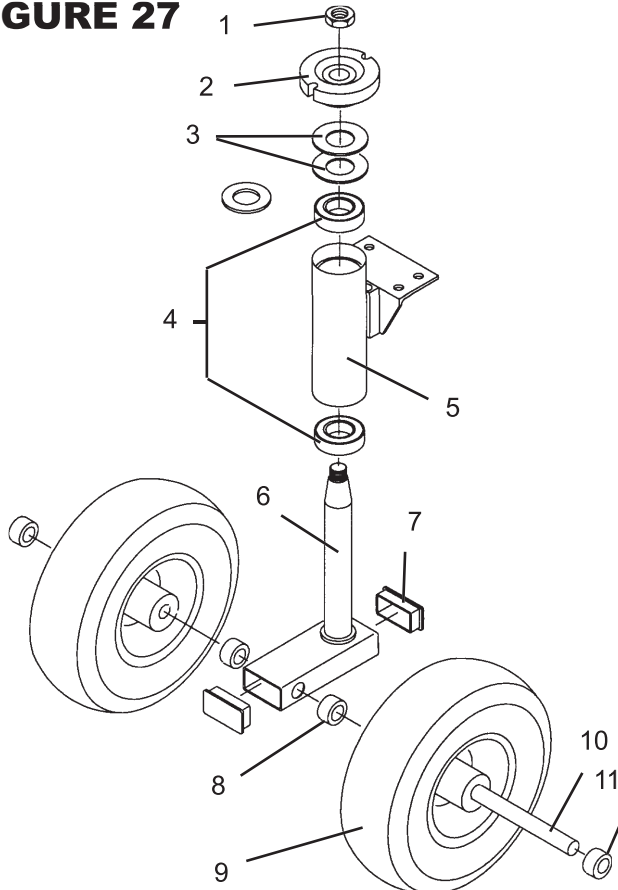

**FIGURE 26 PARTS LIST**

ITEM NO.	PART NO.	DESCRIPTION
1	305-105	Lever
2	136-023	Cable End Lug
3	305-089	Cable Insert
4	305-092-99	Cable Ass'y - Caster
5	305-141	Cable Adjuster
6	305-032	Spring
7	305-081	Lever
8	305-031	Base Lock Weldment
9	305-050	Dowel Pin
10	305-027	Spacer (2)
11	305-049	Cover - Lock
12	305-093	Screw (3)
13	305-094	Washer (3)
14	305-091	Seal
15	305-020	Adjustable Handle (2)
16	119-019	Washer (2)

# SWIVEL ASSEMBLY Part Number 305-022

**FIGURE 27**



**FIGURE 27 PARTS LIST**

ITEM NO.	PART NO.	DESCRIPTION
1	301-227	Jam Nut
2	305-025	Swivel Lock
3	305-028	Belleville Spring (2)
4	301-036	Bearing (2)
5	305-023	Swivel Body
6	305-024	King Pin
7	305-037	Plug (2)
8	113-031	Spacer 1" (2)
9	139-337A	Wheel (2)
10	305-038	Axle
11	143-029	Set Collar



# POWER UNIT ASSEMBLY

**FIGURE 28**

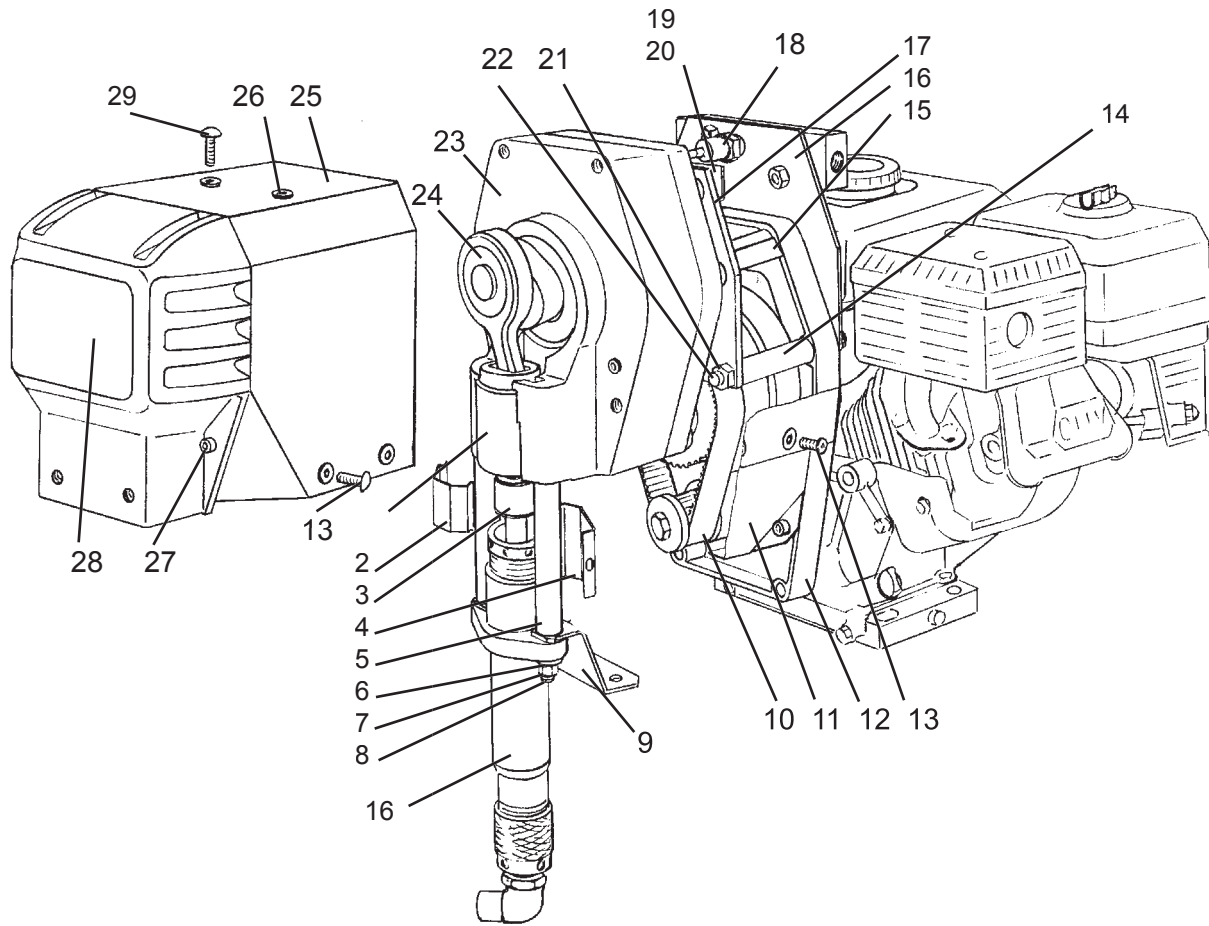
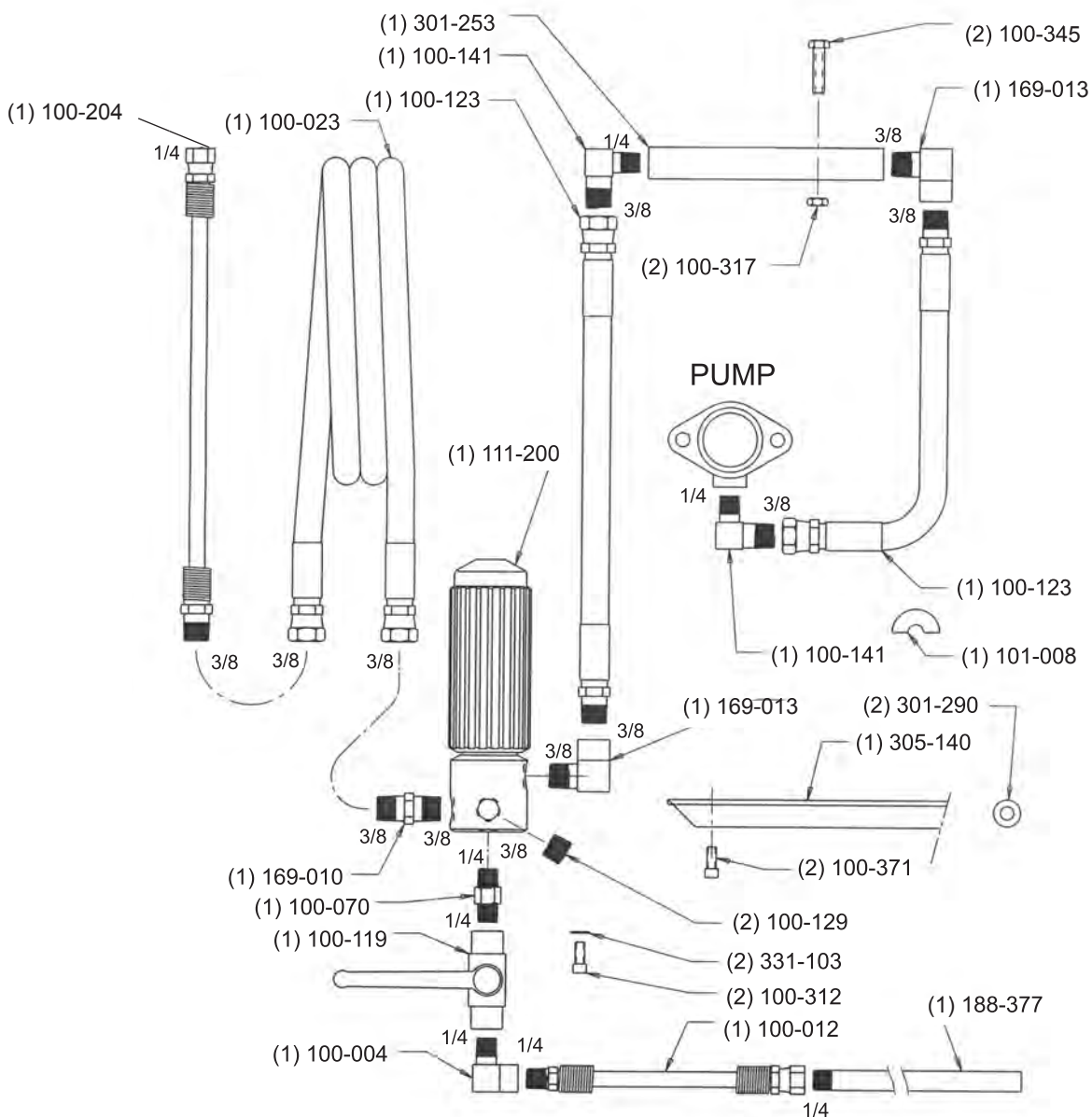

**FIGURE 28 PARTS LIST**

Item No.	Part No.	Description	Item No.	Part No.	Description
1	301-047	Sleeve Bearing	17	305-045	Plate - Gearbox Mount
2	301-189	Shield Front	18	331-294-99	Sensor Ass'y
3	189-046A	Coupling Set Ass'y	19	301-282-99	Pressure Control
4	301-092	Shield - Rear	20	301-523A	Knob Ass'y
5	301-048	Spacer - Tube (2)	21	140-044	Nut (8)
6	140-035	Washer, Lock (2)	22	305-047	Screw (4)
7	140-051	Nut (2)	23	301-207-99	Gearbox 3/4" (model 4500)
8	100-328	Stud (2)		301-208-99	Gearbox 1" (model 6000)
9	305-013	Holder	24	301-291	Connecting Rod Ass'y
10	301-231	Cog Belt	25	301-531	Cover Top
11	305-067	Cover-Bottom	26	301-135	Grommet (6)
12	305-012	Adaptor	27	100-312	Screw (4)
13	100-339	Screw (4)	28	301-320	Cover -Gearbox
14	305-046	Spacer Tube (4)	29	301-337	Screw (2)
15	301-529	Cover			
16	305-064	Holder-Manifold			

# PAINT SYSTEM ASSEMBLY Part Number 305-065

## FIGURE 29



Part #	Description	Part #	Description
100-141	90 Degree Elbow 3/8M X 1/4M (2)	100-317	Nut 5/16-18 Centerlock (2)
169-013	90 Degree Elbow 3/8M X 3/8F (2)	301-290	Spacer 3/8 ID .4 LG (2)
169-010	3/8M X 3/8M Nipple	331-103	Washer .562 X .250 (2)
100-129	3/8 Plug (2)	100-123	Paint Hose 3/8 X 21" (2)
100-004	90 Degree Elbow 1/4M X 1/4F	100-023	Paint Hose 3/8 X 50'
100-070	1/4M X 1/4M Nipple	100-204	1/4" X 5' Whip Hose
100-119	1/4" Ball Valve	100-012	3/16" X 4' Whip Hose
301-253	Manifold	188-377	Return Pipe
100-345	Screw 5/16-18 X 1" (2)	305-140	Filter Bracket
100-312	Screw 1/4-20 X .62 (2)	111-200	Filter Assembly
100-371	Screw 5/16-18 X 1" (2)		



## Reversible REV-TIP™

Part # 560-xxx REV-TIP for Spray Painting  
562-xxxST REV-TIP for Striping

### POSI-LOC™ SYSTEM

Snap in centering of tip.  
No leaks, splashback or mess.

### SEAL LOCATING HANDLE

Tip handle simplifies installing  
& aligning the seal.

### EASIEST ASSEMBLY

Fewer parts - Less complicated  
takes only seconds!

### INTERCHANGEABLE

Can be used with most tip guards.

### HIGHEST QUALITY CARBIDE

Micro-ground for extra long life,  
consistent tip size & pattern.

### STRINGER HOLE

Hang tip from hole for cleaning

### SINGLE-SEAL

Metal seal - no leaks - sprays all coatings.



Each tip individually tested!



Easy to install & align!

**NEW!**

## Quick Flush

*Cuts Cleaning Time  
& Saves Paint!*

Part # 170-005

**Simple to Use...Fast to Finish!**

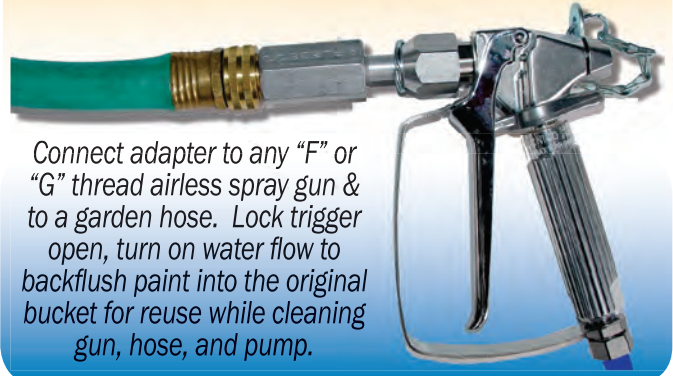

Connect adapter to any "F" or  
"G" thread airless spray gun &  
to a garden hose. Lock trigger  
open, turn on water flow to  
backflush paint into the original  
bucket for reuse while cleaning  
gun, hose, and pump.

Copyright © 2004 Airlessco by Durotech Co. All rights reserved. Product specifications subject to change without notice.

PRODUCT FEATURE	AIRLESSCO REV-TIP™	COMPETITOR A	COMPETITOR B	COMPETITOR C
Aerodynamic Non Drip Guard	●			
Finger Tight Nut	●			
Requires Hand Tight Nut		●	●	●
Snap Tight Tip Lock	●			
Low Profile Guard	●			
Seal Orientation Slot	●			
Tip Handle Hole for Stringer	●			
No Seal Blow-By When Tip is Not in Centered Position (1)	●			●
Seal Orientation Tool on Tip Handle	●			
Non Pin Diffuser (2)	●		●	●
Hardened Cylinder	●	●		
Long Life Metal Seal	●	●	●	
Short Fluid Path (3)	●	●	●	
Tips Fit Graco Bases	●	●	●	
Seal Installer on Tip	●	●	●	
7/8 & 11/16 Gun Thread	●		●	●
Working Pressure Rating	5000 PSI	4050 PSI	5000 PSI	Working Pressure Unknown

(1) Uncontrolled Spray Back Toward User

(2) No Pattern Distortion From Pin

(3) No Spitting

## Spray Gun & Hose Spray Packs



**Part No: 002-013 Spray Pack** includes:

**120-504** ProLight Convertible 4/2-Finger Gun

**100-011** 50' x 1/4" Hi-Flex Airless Hose

**Part No: 002-025 Spray Pack** includes:

**120-502** ProLight 502 Flat Handle Gun

**100-011** 50' x 1/4" Hi-Flex Airless Hose

**Part No: 002-015 Spray Pack** includes:

**120-554** 008 Silver 4-Finger Gun

**100-011** 50' x 1/4" Hi-Flex Airless Hose

See Airlessco REV-TIP™ Brochure (Form 001-449) for  
current listings of available tip sizes including "W" wide  
and FINE FINISH tips for Spraying, & Striping tips.

## REV-GUARD™

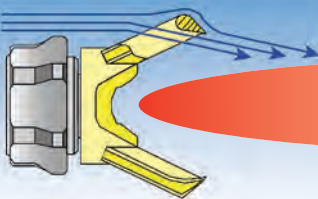

■ Airfoil shape for a clean,  
no-drip application

■ Finger-tight nut, no tools  
required

■ More compact size to use  
in tight areas

Order #

**561-002** REV-GUARD™ with  
with 7/8-14 (G) Thread

**561-001** REV-GUARD™  
with 11/16-16 (F) Thread

# AIRLESSCO ACCESSORIES



## PUMP CONDITIONER

Should be used on piston pumps between uses to prevent paint from drying on the piston & causing packing wear.

- 010-001 Display of 48 - 1 oz. bottles
- 010-009 1 quart bottle
- 010-019 1 Gallon bottle

Case order quantity: 12 on quarts, 4 on gallons



## PAINT STRAINERS

Prefilter your paint using strainer bags. One dozen per pack.

- 100-064 Used to cover suction filter
- 100-065 5 Gallon strainer



## HOSE COVER

4 mil orange poly protects your airless hose from paint and abrasion damage. Comes in 1000' roll with perforations each 50'.

- 100-219 Hose Cover Roll
- 100-426 Case of 6 Rolls



## HIGH PRESSURE HOSE

*Strong yet flexible, suitable for airless equipment up to 3300 PSI*

Part No:

- 100-012 3/16" Whip Hose, 4 Ft.
- 100-011 1/4" Hose, 50 Ft.
- 100-023 3/8" Hose, 50 Ft.
- 100-037 1/2" Hose, 50 Ft.
- 100-010 1/4" Hose Connector
- 100-009 3/8" Hose Connector



## SPRAY TIP ADAPTER

032-012 "F to G" gun adapter to attach Graco® tips to Airlessco 007 Spray Guns.



## GUN FILTERS

- 120-090CX Coarse
- 120-090FX Fine
- 120-088 Filter Spring



For a complete listing of all available accessories see the Airlessco Accessories Catalog, Part # 001-357.



## STAY CLEAN™

Spray protectant for your machine to prevent paint from sticking to it.

- 114-030 20 oz. can



## THROAT SEAL OIL

Used in the wet cup of a piston pump to prevent paint from drying on the piston & causing damage to the upper packing. Use with all piston pumps.

- 188-187 6 oz. Bottle
- 188-392 1 qt. Bottle

## XTEND-A-POLE SYSTEM Tip Extensions - Complete with Patented SPRAY CLEAN REV-GUARD

Swivel Extension

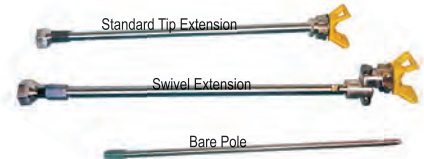

## TIP EXTENSIONS, "G" THREAD

- 032-170 6" Long
- 032-171 12" Long
- 032-172 18" Long
- 032-173 24" Long

## SWIVEL EXTENSION, "G" THREAD

- 032-184 36" Long

## EXTENSIONS (BARE POLES)

Add Tip Extension or Swivel Extension to create desired length

- 032-053 24" Long
- 032-054 36" Long



## SWIVEL "G" THREAD

- 032-035 7/8" - 14 Swivel

## ADAPTERS



- 90° Pole to Gun Adapter  
032-042



- Gun Nut "F" Thread 11/16-16  
032-010



- Gun Nut "G" Thread  
032-011