

# AIRLESSCO®

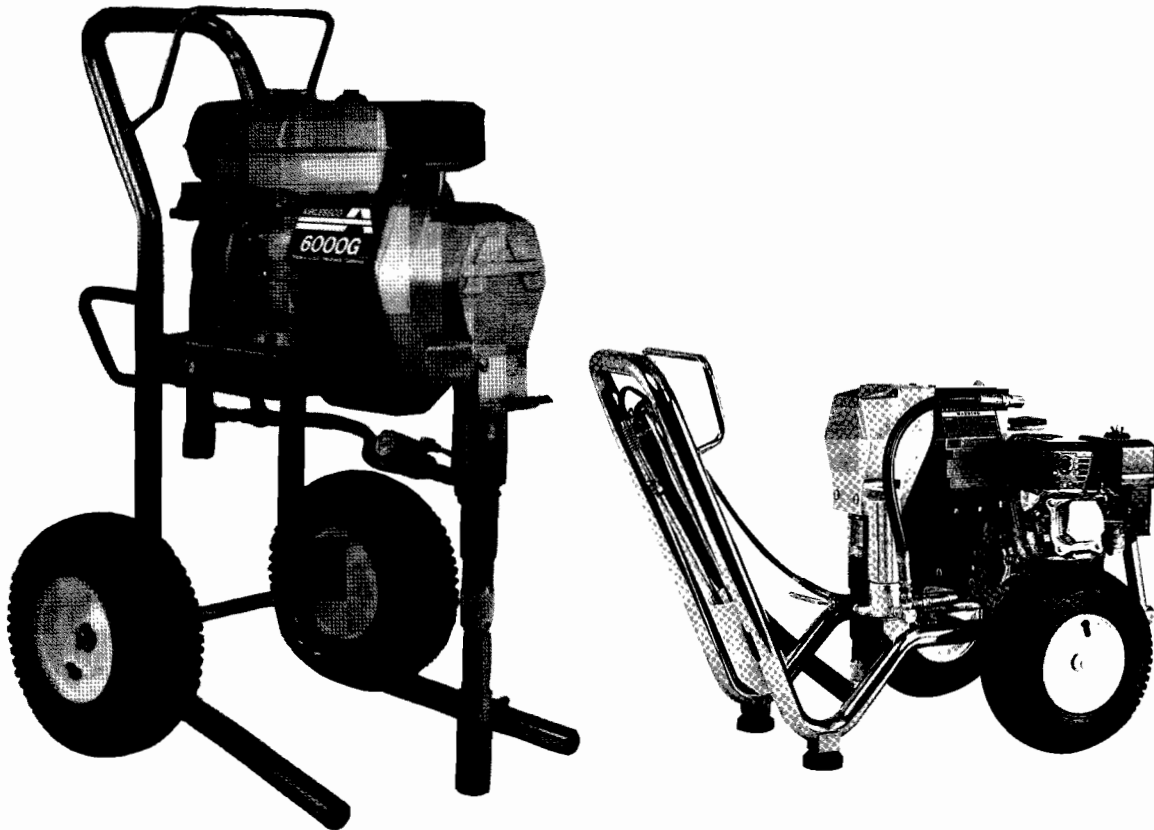

**WARNING:** Before operating, doing any service or maintenance procedure, learn & follow the pressure relief procedure on page 6. Read & understand all warnings on pages 4, 5, 6 and 7

**ALL SERVICE PROCEDURES MUST BE PERFORMED  
BY AUTHORIZED AIRLESSCO SERVICE CENTER.**

## **OPERATION MANUAL AND PARTS LIST FOR MODEL AIRLESSCO 6000G- HI-BOY & LO-BOY AIRLESS PAINT SPRAYERS**

# TABLE OF CONTENTS

|  |             |
|--|-------------|
| Introduction                             | 1           |
| Flushing Guidelines                      | 1           |
| How to Flush                             | 2           |
| Setting Up                               | 3           |
| Starting Up                              | 3 & 4       |
| Warnings                                 | 4, 5, 6 & 7 |
| PRESSURE RELIEF PROCEDURE                | 6           |
| Airlessco 007 Gun Operation              | 8           |
| Spray Tip Selection                      | 9           |
| Airless Spray Gun Operation              | 10          |
| Spray Technique                          | 11 & 12     |
| Airlessco 007 Part Lists & Repair        | 13 & 14     |
| Airlessco 007 Hi Build Mastic Gun        | 14          |
| Regular Maintenance                      | 15          |
| Oil and Lubrication                      | 15          |
| Troubleshooting                          | 15 & 16     |
| Servicing Fluid Pump                     | 16          |
| Servicing Upper & Lower Check Valves     | 17          |
| V-Packing Replacement                    | 18          |
| Fluid Pump Parts List                    | 19          |
| Ball Valve- PN 100-119                   | 20          |
| Troubleshooting - Clutch                 | 20          |
| Replacement of Electrical Board          | 21          |
| Pressure Calibration of Elec. Board      | 21          |
| Clutch Replacement                       | 22 & 23     |
| Clutch Assembly Parts List               | 23          |
| Engine Assembly Parts List               | 24          |
| Paint System Assembly Parts List- Hi-Boy | 25          |
| Paint System Assembly Parts List- Lo-Boy | 26          |
| Power Unit Assembly Lo-Boy               | 27          |
| Complete Sprayer Parts List - Hi-Boy     | 28 & 29     |
| Replacement Parts for Filter             | 30          |
| Maxi-Filter Assembly                     | 30          |
| Suction Assembly- Lo-Boy                 | 30          |
| Frame Assembly Lo-Boy                    | 30          |

# INTRODUCTION

## AIRLESSCO 6000G

This gas powered airless sprayer is built tough to take the day after day demands of contractors. With a stainless steel, severe duty, slow stroking paint pump you have the latest technology in long life pump design with smooth operation and low maintenance.

### Specifications

Pressure 0 - 3000 psi

Output 1.3 gpm

Tip size 1 gun up to 0.035

2 guns up to 0.023

Engine 5.5 hp Honda

## WARNING

**Prior to starting, read, understand and observe all safety precautions and warnings on cover & pages 4, 5, 6 & 7 and all labels and tags on the machine.**

## FLUSHING Read prior to using your sprayer

### 1. New Sprayer

Your Airlessco unit was factory tested in an anti-freeze solution which was left in the pump. Before using oil-base paint, flush with mineral spirits only. Before using water-base paint flush with mineral spirits, followed by soapy water, then a clean water flush.

### 2. Changing Colors

Flush with a compatible solvent such as mineral spirits or water.

### 3. Changing from water-base to oil-base paint.

Flush with soapy water, then mineral spirits.

### 4. Changing from oil-base to water-base paint.

Flush with mineral spirits, followed by soapy water, then a clean water flush.

### 5. Storage

Oil-base paint: Flush with mineral spirits.

Water-base paint: Flush with water, then mineral spirits and leave the pump, hose and gun filled with mineral spirits.

For longer storage, use mixture of mineral spirit and motor oil (half & half). Shut off the sprayer, follow Pressure Relief Procedure on page 6 to relieve pressure and make sure prime valve is left OPEN.

### 6. Start up after storage

Before using water-base paint, flush with soapy water and then a clean water flush.

When using oil-base paint, flush out the mineral spirits with the material to be sprayed.

# HOW TO FLUSH

FIG. 1

REMOVE  
SPRAY  
TIP

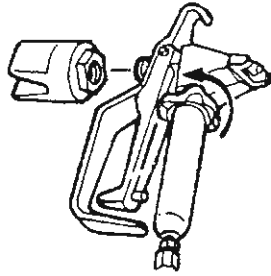
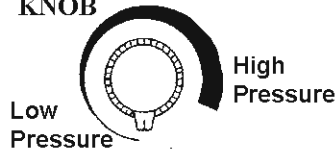

FIG. 2

PRESSURE CONTROL  
KNOB



PRIME VALVE &  
PRESSURE RELIEF  
VALVE

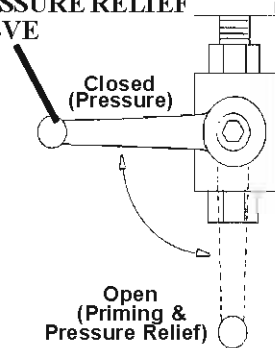

FIG. 3

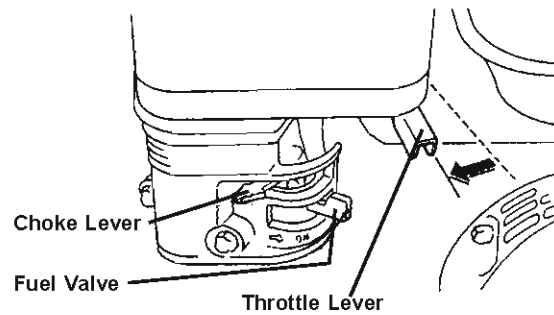
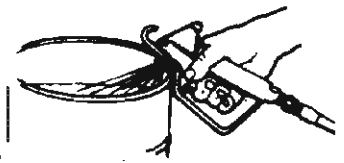

FIG. 4

MAINTAIN FIRM  
METAL TO METAL  
CONTACT BETWEEN  
GUN AND CONTAINER



1. Be sure the gun safety latch is engaged and there is no spray tip in the gun. Refer to Fig. 1. Refer to your separate instruction manual provided with your gun on its safety features and how to engage safety latch.
2. Pour enough clean, compatible solvent into a large, empty metal pail to fill the pump and hoses.
3. Place the suction tube into the pail or place the pail under the pump.
4. Turn the pressure control knob to low pressure. Refer to Fig. 2.
5. Open the prime valve to the open - "Priming Position". This will allow an easy start. Refer to Fig. 2.
6. Turn the engine ON/OFF switch to on.
7. Move the choke to the closed position as per Fig.3.
8. Move the throttle lever slightly to the left as per Fig.3.
9. Turn the fuel valve ON as per Fig. 3. Pull the start rope. Pull the engine over against compression stroke and then let the rope rewind slowly into the starter. Pull firmly and rapidly to start the engine. Do NOT drop the rope. Hold onto the handle while rewinding, or the rope may rewind improperly and jam the assembly. If the engine does not start, open the choke half way. If the engine floods, open the choke all the way and continue cranking.
10. After the engine is warm, gradually open the choke lever, increase the RPM of engine by moving throttle all the way to the left. Close the prime valve. Refer to Fig. 2
11. Point the gun into the metal pail and hold a metal part of the gun firmly against the pail Refer to fig. 4.

**WARNING: To reduce the risk of static sparking, which can cause fire or explosion, always hold a metal part of the gun firmly against the metal pail when flushing. This also reduces splashing. Refer to Fig.4.**

12. Disengage the gun safety latch and squeeze the gun trigger. At the same time, slowly turn the pressure control knob clockwise just enough to move liquid at low pressure.
13. Allow the pump to operate until clean solvent comes from the gun.
14. Release the trigger and engage the gun safety latch.
15. If you are going to start spraying, place the pump or suction tube into the supply container. Release the gun safety latch and trigger the gun into another empty, metal container, holding a metal part of the gun firmly against the metal pail (Fig. 4) and force the solvent from the pump and hose. When paint starts coming from gun, turn pressure control knob to minimum pressure, place prime valve in prime (open) position and engage the gun safety latch.
16. If you are going to store the sprayer, remove the suction tube or pump from the solvent pail force the solvent from the pump and hose. Engage the gun safety latch and refer to the "Storage" Procedure on page 1. Step 5.
17. Whenever you shut off the sprayer follow the Pressure Relief Procedure warning on page 6.

# SETTING UP

## 1. Connect the hose and gun.

- Remove the plastic cap plug from the outlet and screw a conductive or grounded 3000 psi spray hose onto fluid outlet.
- Connect an airless spray gun to the other end of the hose, but do not install the spray tip yet!

**NOTE:** Do not use thread sealer on swivel unions as they are made to self seal. Use thread seal on tapered male threads only.

**NOTE:** The first 50' of hose should always be 3/8".

**2. Fill the Packing Nut/Wet Cup** 1/3 full with Throat Seal Oil (TSO) supplied. Fig 5 below.

**FIG. 5**

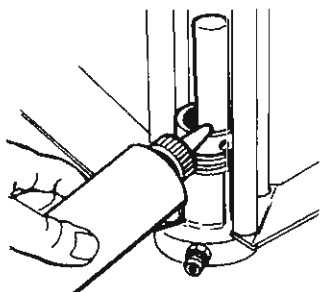

## 3. Check the Engine Oil Level.

- Unscrew the oil fill plug. The dipstick is attached to the plug.
- Without threading the plug into place, check to be sure the oil is up to the top mark on the dipstick.
- If oil is needed, refer to engine manual.

**NOTE:** Unit is shipped without oil in engine.

## 4. Fill the Fuel Tank

**WARNING: Fuel spilled on a hot surface can cause a fire or explosion and cause serious bodily injury and property damage. Always shut off the engine and let it cool before filling the tank, and carefully follow steps a - c below being sure not to spill any fuel.**

- Close the fuel shutoff valve.
- Use only clean, fresh, well-known brands of unleaded regular grade gasoline.
- Remove the fuel cap and fill tank. Be sure the air vent in the fill cap is not plugged so fuel can flow to the carburetor, then replace the cap.

## 5. Flush the sprayer.

See "Flushing" page 1 & 2. Your new pump was factory tested in an anti-freeze solution and it must be flushed before using.

# STARTING UP

## 1. Learn the controls.

**Pressure Control Knob** - used to adjust pressure only. Turn clockwise to increase pressure and counterclockwise to decrease pressure. (See Fig. 6)

**Prime & Pressure Relief Valve** - Turn to OPEN position (see Fig. 7) to prime the pump. Turn to the CLOSED position to spray.

**FOLLOW THE "PRESSURE RELIEF PROCEDURES" ON PAGE 6 WHENEVER YOU:**

- are instructed to relieve pressure
- stop spraying
- checking or servicing any of the system equipment.
- or installing or cleaning the spray tip.

Handle Spray system as you would a loaded firearm.

**CAUTION: Do not start engine without fluid pump having enough fluid so that it can be primed. Running fluid pump dry will decrease life of the pumps packings.**

## 2. Prepare the Material

- Prepare the material according to the material manufacturer's recommendations.
- Place the pump or suction tube into the material container.

**FIG. 6**

**PRESSURE CONTROL KNOB**



**FIG. 7**

**Closed (Pressure)**

**PRIME VALVE & PRESSURE RELIEF VALVE**

**Open (Priming & Pressure Relief)**

## 3. Starting the Sprayer (see Fig. 6 & 7 above)

- Prime Valve must be open - priming position.
- Pressure Control Knob must be in low pressure.
- Follow the procedure under "How to Flush", page 2, Steps 6 through 12.

**WARNING: To stop the unit in an emergency or before performing any service or maintenance procedure follow the Pressure Relief Procedure on page 6 to relieve the fluid pressure.**

# STARTING UP CONTINUED

## 4. Prime the Pump

- Allow pump to operate until paint comes from gun.
- Release the trigger and engage the gun safety latch.
- Turn Prime Valve OPEN to the prime position ensuring the pressure is released from the system.
- Turn Pressure Control Knob to minimum pressure.
- Install spray tip onto gun.
- Close the prime valve to the pressure position.
- Turn the pressure control knob to desired spray pressure.
- Disengage the gun safety lock and you are ready to start spraying.

**WARNING: If you spray into the paint bucket, always use the lowest spray pressure and maintain firm metal to metal contact between gun and container. See page 2, Fig 4.**

## 5. Adjusting the Pressure

- Turn the Pressure Control Knob clockwise to increase pressure and counterclockwise to decrease pressure.
- Always use the lowest pressure necessary to completely atomize the material.

**CAUTION - Operating the sprayer at higher pressure than needed wastes material, causes early tip wear and shortens sprayer life.**

- If more coverage is needed use a larger tip rather than increasing the pressure.
- Check the spray pattern. The tip size and angle determines the pattern width and flow rate.

## 6. Reducing Clutch Wear

- The first 50 feet of airless spray hose should be 3/8", the larger diameter works as a pulsation damper and saves unnecessary cycling of the clutch. A minimum of 100 feet of hose should be used.
- Adjust the Engine Speed and Pump Pressure. First set the throttle lever to the maximum RPM setting (fully left). Trigger the gun onto a test paper to check the spray pattern and atomization. Adjust the Pressure Control Knob until you get a good pattern.

## 7. Cleaning a Clogged Tip.

### IMPORTANT

**WARNING:** Always follow the Pressure Relief Procedure on page 6 before performing any service or maintenance procedure.

**WARNING:** Never hold your hand, body, fingers, or hand in a rag in front of the spray tip when cleaning or checking it for a cleared tip. Always point the gun toward the front or into a waste container when checking to see if the tip is cleared or when using a self-cleaning tip.

- Follow the Pressure Relief Procedure on page 6.
- Clean the front of the tip frequently (with toothbrush only) during the day to keep material from building up and clogging the tip.
- To clean and clear a tip if it clogs, refer to the separate instruction manual received with your gun and nozzle.

*There is an easy way to keep the outside of the tip clean from material build-up:*

*Every time you stop spraying, for even a minute, lock the gun and submerge the gun into a small bucket of thinner comparable with the material sprayed. Thinner will dissolve the build up of paint on the outside of tip, tip guard and gun much more effectively than if the paint dries out completely.*

**WARNING: Clogged standard flat tip - clean only after the tip is removed from the gun. Follow the Pressure Relief Procedure Warning on Page 6.**

## 8. When Shutting Off the Sprayer

- Whenever you stop spraying, even for a short break, follow the Pressure Relief Procedure on page 6.
- Clean the tip and gun as recommended by your separate gun instruction manual.
- Flush the sprayer at the end of each work day if the material you are spraying is waterbased, or if it could harden in the sprayer overnight. See "Flushing" page 1 and 2. Use a compatible solvent to flush, then fill the pump and hoses with an oil based solvent such as mineral spirits.
- For long term shutdown or storage, refer to page 1.

**WARNING - Be sure to relieve pressure in the pump after filling with mineral spirits.**

# WARNINGS

## MEDICAL ALERT - Airless Spray Wounds

*If any fluid appears to penetrate your skin, get **EMERGENCY MEDICAL CARE AT ONCE. DO NOT TREAT AS A SIMPLE CUT.** Tell the doctor exactly what fluid was injected. Have him read the following "NOTE TO PHYSICIAN".*

**NOTE TO PHYSICIAN:** *Injection in the skin is a traumatic injury. It is important to treat the injury surgically as soon as possible. DO NOT DELAY treatment to research toxicity. Toxicity is a concern with some exotic coatings injected directly into the blood stream. Consultation with a plastic surgeon or reconstructive hand surgeon may be advisable.*

# WARNINGS

**HIGH PRESSURE SPRAY CAN CAUSE EXTREMELY SERIOUS INJURY.  
OBSERVE ALL WARNINGS. THIS SPRAYER IS FOR PROFESSIONAL USE ONLY.**

## **INJECTION HAZARD**

**Fluids under high pressure from spray or leaks can penetrate the skin and cause extremely serious injury, including the need for amputation.**

*NEVER* point the spray gun at anyone or any part of the body.

*NEVER* put hand or fingers over the spray tip. Do not use rag or other materials over your fingers. Paint will penetrate through material and into the hand.

*NEVER* try to stop or deflect leaks with your hand or body.

*ALWAYS* have gun tip guard in place when spraying.

*ALWAYS* lock gun trigger when you stop spraying.

*ALWAYS* remove tip from the gun to clean it.

*NEVER* try to "blow back" paint, this is not an air spray sprayer.

*ALWAYS* follow the **PRESSURE RELIEF PROCEDURE**, as shown on page 6, before cleaning or removing the spray tip or servicing any system equipment.

Be sure equipment safety devices are operating properly before each use.

Tighten all fluid connections before each use.

## **MEDICAL TREATMENT**

If any fluid appears to penetrate your skin, get **EMERGENCY CARE AT ONCE. DO NOT TREAT AS A SIMPLE CUT.**

\* Go to an emergency room immediately.

\* Tell the doctor you suspect an injection injury.

\* Tell him what kind of material you were spraying with and have him read **NOTE TO PHYSICIAN** on page 4.

## **GENERAL PRECAUTIONS**

*NEVER* alter equipment in any manner.

*NEVER* smoke while in spraying area.

*NEVER* spray highly flammable materials.

*NEVER* use around children.

*NEVER* allow another person to use sprayer unless he is thoroughly instructed on its' safe use and given this operators manual to read.

*ALWAYS* wear a spray mask, gloves and protective eye wear while spraying.

*ALWAYS* ensure fire extinguishing equipment is readily available and properly maintained.

***NEVER LEAVE SPRAYER UNATTENDED WITH PRESSURE IN THE SYSTEM. FOLLOW PRESSURE RELIEF PROCEDURES ON PAGE 6.***

## **TOXIC FLUID HAZARD**

Hazardous fluid or toxic fumes can cause serious injury or death if splashed in eyes or on skin, inhaled or swallowed. Know the hazards of the fluid you are using. Store & dispose of hazardous fluids according to manufacturer, local, state & national guidelines.

*ALWAYS* wear protective eyewear, gloves, clothing and respirator as recommended by fluid manufacturer.

## **ALWAYS INSPECT SPRAYING AREA**

Keep spraying area free from obstructions.

Make sure area has good ventilation to safely remove vapors and mists.

*NEVER* keep flammable material in spraying area.

*NEVER* spray in vicinity of open flame or other sources of ignition.

Spraying area must be at least 20 ft. away from spray unit.

## **SPRAY GUN SAFETY**

*ALWAYS* set safety lock on the gun in "LOCKED" position when not in use and before servicing or cleaning.

**DO NOT** remove or modify any part of gun.

*ALWAYS REMOVE SPRAY TIP* when cleaning. Flush unit with **LOWEST POSSIBLE PRESSURE.**

**CHECK** operation of all gun safety devices before each use.

Be very careful when removing the spray tip or hose from gun. A plugged line contains fluid under pressure. If the tip or line is plugged, follow the **PRESSURE RELIEF PROCEDURE** as outlined on page 6.

## **TIP GUARD**

*ALWAYS* have the tip guard in place on the spray gun while spraying. The tip guard alerts you to the injection hazard and helps prevent accidentally placing your fingers or any part of your body close to the spray tip.

## **SPRAY TIP SAFETY**

Use extreme caution when cleaning or changing spray tips. If the spray tip clogs while spraying, engage the gun safety latch immediately. *ALWAYS* follow the **PRESSURE RELIEF PROCEDURE** and then remove the spray tip to clean it.

*NEVER* wipe off build up around the spray tip.

*ALWAYS* remove tip & tip guard to clean **AFTER** pump is turned off and the pressure is relieved by following the **PRESSURE RELIEF PROCEDURE.**

## **KEEP CLEAR OF MOVING PARTS**

Keep clear of moving parts when starting or operating the sprayer. Do not put your fingers into any openings to avoid amputation by moving parts or burns on hot parts.

Precaution is the best insurance against an accident. When starting the engine, maintain a safe distance from moving parts of the equipment.

Before adjusting or servicing any mechanical part of the sprayer, follow the **PRESSURE RELIEF PROCEDURE** on page 6, and remove the ignition cable from the spark plug to prevent accidental starting of sprayer.

**WARNINGS CONTINUED ON NEXT PAGE.....**

# WARNINGS continued

## PRESSURE RELIEF PROCEDURE

To avoid possible serious bodily injury, including injection, always follow this procedure whenever the sprayer is shut off, when checking or servicing it, when installing or changing the tips, whenever you stop spraying or when you are instructed to relieve the pressure.

1. Engage gun safety latch. Refer to separate instruction manual provided with your gun on its safety features and how to engage safety latch.

2. Turn engine off.

3. Disengage safety latch & trigger gun to relieve residual fluid pressure. Hold metal part of the gun in contact with grounded metal pail



4. Re-engage gun safety latch

5. Turn Prime/Pressure Relief Valve as shown open (priming) to relieve fluid pressure.

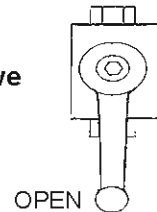

Leave prime valve OPEN until you are ready to spray again.

**IF THE SPRAY TIP OR HOSE IS CLOGGED, follow Step 1 through 5 above. Expect paint splashing into the bucket while relieving pressure during Step 5. If you suspect that pressure hasn't been relieved due to damaged prime/pressure relief valve or other reason, engage gun safety latch and take your sprayer to an authorized Airlessco Service Center for service.**

Always follow recommended pressure & operating instructions

## **HOSES**

Tighten all fluid connections securely before each use. High pressure fluid can dislodge a loose coupling or allow high pressure spray to be emitted from the coupling and result in an injection injury or serious bodily injury.

Use only hose that has a spring guard. The spring guard helps protect the hose from kinks or other damage which could result in hose rupture and cause an injection injury.

NEVER use a damaged hose, which can result in hose failure or rupture and cause in injection injury or other serious bodily injury or bodily damage. Before each use, check entire hose for cuts, leaks, abrasion or bulging of cover, or damage or movement of couplings. If any of these conditions exist, replace the hose immediately. Never use tape or any device to try to mend the hose as it cannot contain the high pressure fluid. NEVER ATTEMPT TO RECOUPLE THE HOSE. High pressure hose is not recoupleable.

Help prevent damage to the hose by handling and routing carefully. Do not move the sprayer by pulling it with the hose.

## **LABELING**

Keep all labels on the unit clean and readable. Replacement labels are available from manufacturer.

## **GROUNDING**

Ground the sprayer and other components in the system to reduce the risk of static sparking, fire or explosion which can result in serious bodily injury and property damage.

Always ground all of these components:

1. Sprayer: Connect a ground wire and clamp (supplied) to a true earth ground.
2. Fluid Hose: use only grounded hoses.
3. Spray gun or dispensing valve: grounding is obtained through connection to a properly grounded fluid hose and pump.
4. Object being sprayed: according to your local code.
5. All solvent pails used when flushing should only be metal pails which are conductive.

Once each week, check electrical resistance of hose (when using multiple hose assemblies, check overall resistance of unpressurized hose must not exceed 29 megohms (max) for any coupled length or combination of hose lengths. If hose exceeds these limits, replace it immediately.

Never exceed 500 Ft. (150 m.) overall combined hose length to assure electrical continuity.

**NOTE: WARNINGS CONTINUE ON NEXT PAGE.**



# WARNINGS continued

## AVOID COMPONENT RUPTURE

This sprayer operates at 3000 psi (205 bar). Always be sure that all components and accessories have a maximum working pressure of at least 3000 psi to avoid rupture which can result in serious bodily injury including injection and property damage.

NEVER leave a pressurized sprayer unattended to avoid accidental operation of it which could result in serious bodily injury.

ALWAYS follow the PRESSURE RELIEF PROCEDURE whenever you stop spraying and before adjusting, removing or repairing any part of the sprayer.

NEVER alter or modify any part of the equipment to avoid possible component rupture which could result in serious bodily injury and property damage.

NEVER use weak or damaged or non-conductive paint hose. Do not allow kinking or crushing of hoses or allow it to vibrate against rough or sharp or hot surfaces. Before each use, check hoses for damage and wear and ensure all fluid connections are secure.

REPLACE any damaged hose. NEVER use tape or any device to mend the hose.

NEVER attempt to stop any leakage in the line or fittings with your hand or any part of the body. Turn off the unit and release pressure by following PRESSURE RELIEF PROCEDURE.

ALWAYS use approved high pressure fittings and replacement parts.

ALWAYS ensure fire extinguishing equipment is readily available and properly maintained.

## WARNING

**Do not use halogenated solvents in this system. The prime valve, 2 gun manifold and most airless guns have aluminum parts and may explode. Cleaning agents, coatings, paints or adhesives may contain halogenated hydrocarbon solvents. DON'T TAKE CHANCES! Consult your material suppliers to be sure. Some of the most common of these solvents are: Carbontetrachloride, Chlorobenzene, Dichloroethane, Dichloroethyl Ether, Ethylbromide, Ethylchloride, Tetrachloroethane. Alternating valves and guns are available if you need to use these solvents.**

## PREVENT STATIC SPARKING FIRE/ EXPLOSIONS

ALWAYS be sure all equipment and objects being sprayed are properly grounded. Always ground sprayer, paint bucket and object being sprayed. See "grounding" on page 6 for detailed grounding information.

Vapors created when spraying can be ignited by sparks. To reduce the risk of fire, always locate the sprayer at least 20 feet (6 m.) away from the spray area. Do not plug in or unplug any electrical cords in the spray area, which can create sparks, when there is any chance of igniting vapors still in the air. Follow the coating & solvent manufacturers safety warnings and precautions.

Use only conductive fluid hoses for airless applications. Be sure gun is grounded through hose connections. Check ground continuity in hose & equipment. Overall (end to end) resistance of unpressurized hose must not exceed 29 megohms for any coupled length or combination of hose length. Use only high pressure airless hoses with static wire approved for 3000 psi.

## FLUSHING

Reduce the risk of injection injury, static sparking or splashing by following the specific cleaning procedure on pg. 7.

ALWAYS follow the PRESSURE RELIEF PROCEDURE on page 6.

ALWAYS remove the spray tip before flushing. Hold a metal part of the gun firmly to the side of a metal pail and use the lowest possible fluid pressure during flushing. NEVER use cleaning solvents with flash points below 140 degrees F. Some of these are: acetone, benzene, ether, gasoline, naphtha. Consult your supplier to be sure. NEVER SMOKE IN THE SPRAYING/CLEANING AREA.

## GAS ENGINE PRECAUTIONS

Locate unit 25 feet away from spray area in well ventilated area. NEVER operate in closed building unless exhaust is piped outside. NEVER allow hose to lay against engine mufflers or hot parts. NEVER refill fuel tank while engine is hot or is running.

**Important: United States Government safety standards have been adopted under the Occupational Safety & Health Act. These standards, particularly the General Standards, Part 1910, & the Construction Standards, part 1926 should be consulted.**

## WHEN SPRAYING & CLEANING WITH FLAMMABLE PAINTS OR THINNERS:

1. When spraying with flammable liquids, the unit must be located a minimum of 25 feet away from the spraying area in a well ventilated area. Ventilation must be sufficient enough to prevent the accumulation of vapors.
2. To eliminate electrostatic discharge, ground the spray unit, paint bucket and spraying object. Use only high pressure airless hoses approved for 3000 psi which is conductive.
3. Remove spray tip before cleaning gun and hose. Make contact of gun with bucket and spray without the tip in a well ventilated area, into the grounded steel bucket.
4. Never use high pressure in the cleaning process. USE MINIMUM PRESSURE.
5. Do not smoke in spraying/cleaning area.

# AIRLESSCO 007 SPRAY GUN

Attach spray gun to whip hose and tighten fittings securely. Set the gun safety latch. (Also may be called gun safety lock) \* Refer to Fig. A.

\*The gun safety latch should always be set when the gun is not being triggered.

Read all warnings and safety precautions supplied with the spray gun and in product manual.

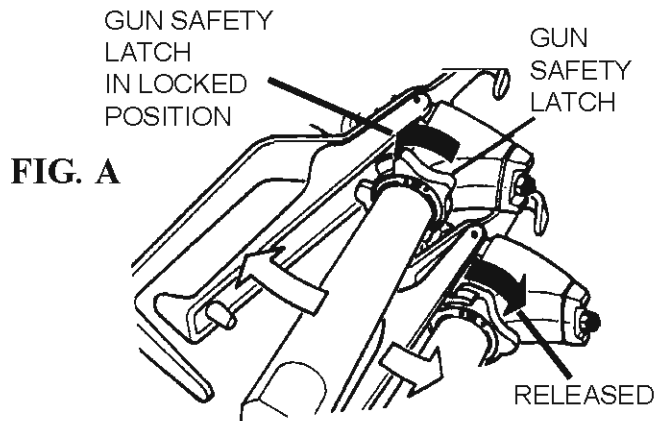

## MAJOR COMPONENTS OF SPRAY GUN AND REVERSIBLE SPRAY TIP

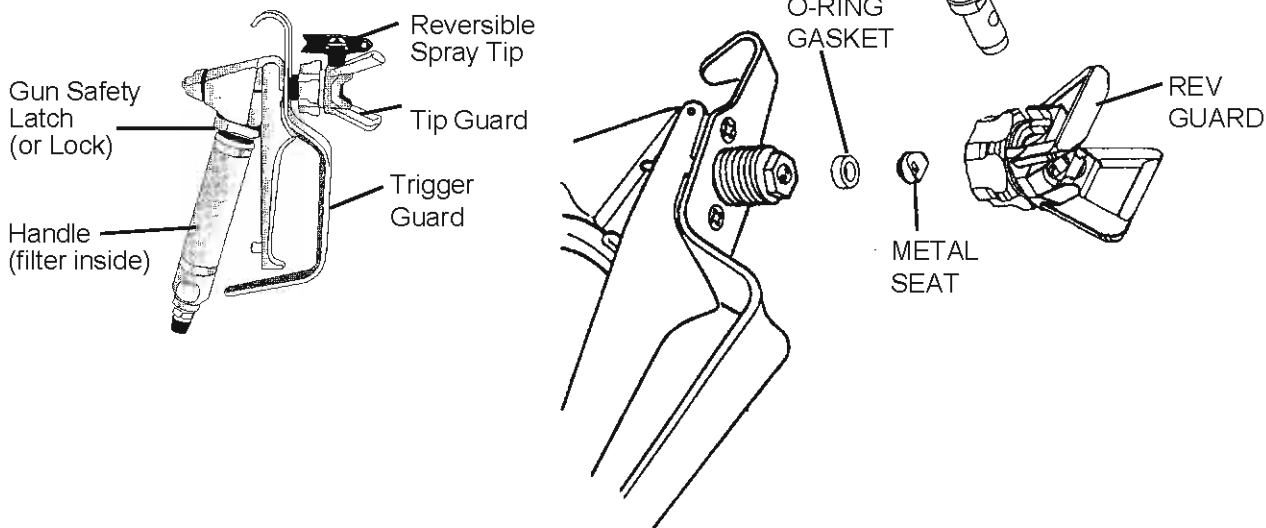

### SPRAY TIP ASSEMBLY

1. Be sure the pressure relief procedure is followed before assembling tip and housing to the gun.
2. Insert Rev-Tip cylinder into REV-GUARD (guard housing assembly).
3. Guide the metal seat into REV-GUARD (guard housing assembly) through the retaining nut and turn until it seats against the cylinder.
4. Insert the O ring gasket onto the metal seat so that it fits into the grooves.
5. Finger tighten the REV-GUARD retaining nut onto the gun.
6. Turn guard in the desired position.
7. Completely tighten the retaining nut.

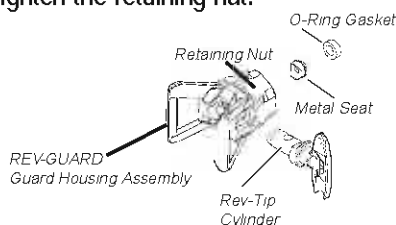

### TO REMOVE CLOGS FROM SPRAY TIP

1. Lock gun trigger.
2. Turn Rev-Tip handle 180 degrees.
3. Disengage trigger lock and trigger gun into pail.
4. If the Rev-Tip handles appears locked (resists turning) loosen the retaining nut. Then handle will now turn easily.
5. Engage trigger lock and return handle to the spray position.

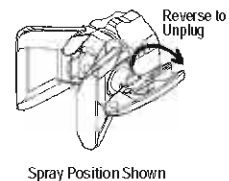

# SPRAY TIP SELECTION

Spray tip selection is based on paint viscosity, paint type, and job needs. For light viscosities (thin paints), use a smaller tip; for heavier viscosities (thicker paints), use a larger tip size.

Spray tip size is based on how many gallons of paint per minute can be sprayed through the tip. Do not use a tip larger than the maximum pump flow rate or capacity the sprayer can accommodate. Pump flow rate is measured in gallons per minute (GPM).

## TIP SELECTION CHART

### FULL RANGE OF TIP SIZES

REV -TIPS (P.N. 560-XXX)  
FLAT TIPS (P.N. 570-XXX)

*Tip Identification: All tips have a 6 digit part number. The first 3 digits identifies it as a Rev-Tip (560) or a Flat Tip (570). The 4th digit is the fan width - the number is half the fan width, ie. 5 means a 10" fan when it is held 12" from the surface. The 5th and 6th digit is for the orifice size and is measured in thousands of an inch, ie: 17 = 0.017 inch- the higher the number, the larger the tip.*

For sizes not shown, call factory for availability.

| Fan Width                                       |  | Orifice Size (Inch) |      |        |        |      |             |        |               |        |        |        |
|---|--|---------------------|------|--------|--------|------|-------------|--------|---------------|--------|--------|--------|
| in.   | (mm)   | .011                | .013 | .015   | .017   | .019 | .021        | .023   | .025          | .027   | .031   | .035   |
| 4-6   | (102-152)  | 211                 | 213  | 215    | 217    | 219  |             |        |               |        |        |        |
| 6-8   | (152-203)  | 311                 | 313  | 315    | 317    | 319  | 321         | 323    | 325           | 327    |        |        |
| 8-10  | (203-254)  | 411                 | 413  | 415    | 417    | 419  | 421         | 423    | 425           | 427    | 431    |        |
| 10-12   | (254-305)  | 511                 | 513  | 515    | 517    | 519  | 521         | 523    | 525           | 527    | 531    | 535    |
| 12-14   | (305-356)  |                     | 613  | 615    | 617    | 619  | 621         | 623    | 625           | 627    | 631    | 635    |
| 14-16   | (356-406)  |                     |      | 715    | 717    |      | 721         |        |               |        |        |        |
| 16-18   | (406-457)  |                     |      | 815    |        | 819  | 821         |        |               |        | 831    |        |
| Water Flow Rate                                 | (gpm)  | .12                 | .18  | .24    | .31    | .38  | .47         | .57    | .67           | .77    | 1.03   | 1.31   |
| Tip Flow Rate-water                             | (lpm)<br>(Water @ 2000 psi, 138 bar)                                 | .49                 | .69  | .91    | 1.17   | 1.47 | 1.79        | 2.15   | 2.54          | 2.96   | 3.90   | 4.98   |
| Paint Flow Rate                                 | (gpm)  | .10                 | .15  | .21    | .27    | .33  | .40         | .49    | .58           | .66    | .88    | 1.12   |
| Tip Flow Rate-water                             | (lpm)<br>(latex paint @ 2000 psi, 138 bar/1 36 spec)                 | .38                 | .57  | .79    | 1.02   | 1.25 | 1.51        | 1.85   | 2.20          | 2.50   | 3.33   | 4.24   |
| Pump Minimum -paint                             | (gpm)  | .25                 | .25  | .33    | .40    | .50  | .60         | .75    | .88           | 1.0    | 1.25   | 1.5    |
| Output* Rate -water                             | (lpm)  | 1.0                 | 1.0  | 1.25   | 1.5    | 1.9  | 2.3         | 2.8    | 3.3           | 3.8    | 4.7    | 5.7    |
| *Pump will support tip worn to next larger size |  |                     |      |        |        |      |             |        |               |        |        |        |
| Gun Filter                                      | C= Coarse - 60 mesh<br>F= Fine - 100 mesh                            | F                   | F    | F,C    | C      | C    | C           | C      | REMOVE FILTER |        |        |        |
| Wood Interior                                   | Lacquer, Varnish<br>Stain, Sealer<br>Enamel                          | •<br>•              | •    | •      |        |      |             |        |               |        |        |        |
| Wood Exterior                                   | Exterior Stain<br>Vinyl, Acrylic, Latex                              |                     |      | •      | •      | •    | •           |        |               |        |        |        |
| Masonry   | Vinyl, Oil Base Alkyd<br>Latex, Acrylic<br>Block Filler<br>Elastomer |                     |      | •<br>• | •<br>• | •    | •<br>•<br>• | •<br>• | •<br>•        | •<br>• | •<br>• | •<br>• |
| Ceiling   | Hi Build, Mil White  |                     |      |        |        |      | •<br>•      | •<br>• |               |        |        |        |
| Structural Steel                                | Heavy Coatings   |                     |      |        |        |      | •<br>•      | •<br>• | •<br>•        | •<br>• | •<br>• | •<br>• |

Consult your paint manufacturer for application recommendation.

### PATTERN WIDTH

Thickness of the paint coat per stroke is determined by spray tip "fan width", rate of the spray gun movement, and distance to surface.

### SPRAY TIP SELECTION

Two tips having the same tip size, but different pattern widths will deliver the same amount of paint over a different area (wider or narrower strip).

A spray tip with a narrow pattern width makes it easy to spray in tight places.

### SPRAY TIP REPLACEMENT

During use, especially with latex paint, high pressure will cause the orifice to grow larger. This destroys the pattern.

Replace tips before they become excessively worn. Worn tips waste paint, cause overspray, make cutting-in difficult, and decreases sprayer performance.

# AIRLESS SPRAY GUN OPERATION

| DEFECTS   | CAUSE  | CORRECTION  |
|---|--|---|
| Coarse spray                                    | Low pressure   | Increase the pressure.  |
| Excessive fogging (overspray)                   | High pressure<br>Material too thin   | Reduce the pressure to satisfactory pattern distribution.<br>Use less thinner.  |
| Pattern too wide                                | Spray angle too large  | Use smaller spray angle tip.  |
| Pattern too narrow                              | Spray angle too small  | Use larger spray angle tip (if coverage is OK, try tip in same nozzle group)  |
| Too much material                               | Nozzle too small<br>Material too thin<br>Pressure too high   | Use next smaller nozzle.<br>Reduce pressure   |
| Too little material                             | Nozzle too small<br>Material too thick   | Use next larger nozzle  |
| Thin distribution in center of pattern "horns". | Worn tip<br>Wrong tip  | Change for new tip.<br>Use nozzle with a narrow spray angle.  |
| Thick skin on work                              | Material too viscous<br>Application too heavy  | Thin cautiously.<br>Reduce pressure and/or use tip in next larger nozzle group.   |
| Coating fails to close & smooth over            | Material too viscous   | Thin cautiously.  |
| Spray pattern irregular, deflected              | Orifice clogged.<br>Tip damaged  | Clean carefully.<br>Replace with new tip.   |
| Craters or pock marks, bubbles on work          | Solvent balance  | Use 1 to 3% "short" solvents remainder "long" sol (this is most likely to happen with material of low viscosity, lacquers etc.)   |
| Clogged screens                                 | Extraneous material in paint<br>Coarse pigments<br>Poorly milled pigments<br>(paint pigments glocculate cover screen. Incompatible paint mixture & thinners. | Clean screen<br>Use coarse screen if orifice size allows.<br>Use coarser screen, larger orifice tips. Obtain ball milled paint. If thinner has been added, test to see if a drop placed on top of paint mixes or flattens out on the on the surface. If not, try different thinner in fresh batch of paint. |

## TEST THE PATTERN

Good, full pattern.



Spotty Pattern-  
Increase Pressure



# SPRAY TECHNIQUE

Good Spray Gun Technique is at the core of any spray paint operation. Operator skill and efficiency is as important as good equipment and good paint. Good spray technique is a skill that can be quickly learned by following these simple instructions.

If you are not familiar with spraying techniques, we recommend that you study this section of your manual and practice the proper technique on pieces of cardboard or a suitable surface.

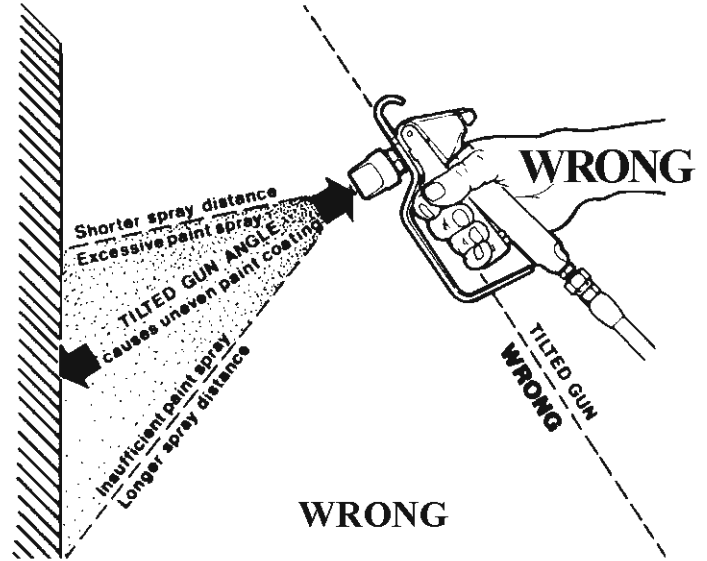
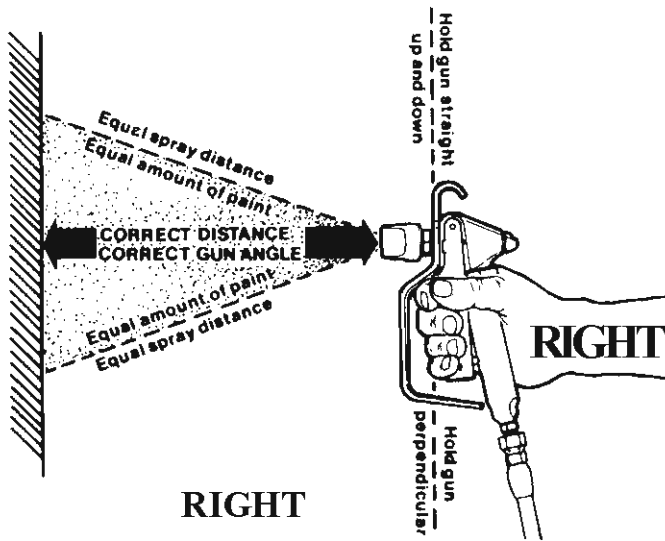

Hold the spray gun 12 - 15 inches away from the work surface and keep it perpendicular (straight) to the surface. Move the spray gun parallel to the work and at a right angle to the surface.

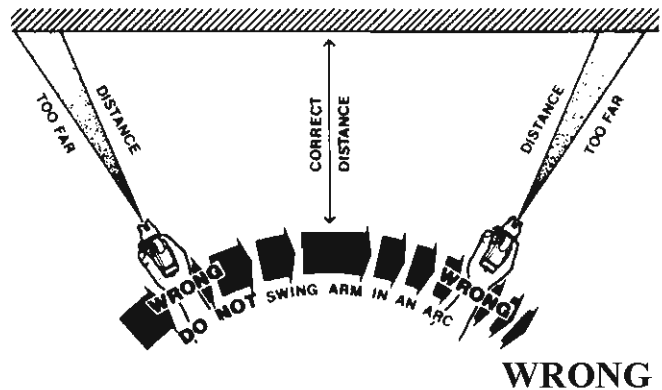
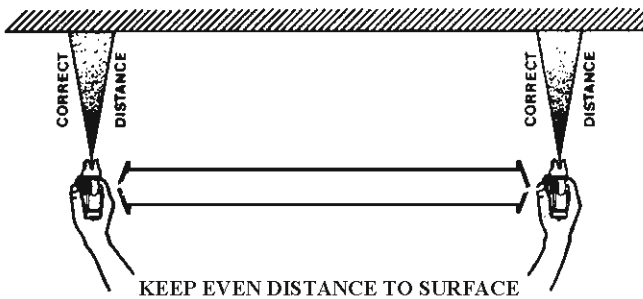

Move the gun at a steady rate in order to apply a good coverage. The wet coat should be just under the thickness at which a run or sag will occur. slow gun movement or gun held too close will result in an overly wet or thick wet or thick coat coverage that is likely to run or sag.

The closer the spray gun is held to the work, the thicker the paint is deposited and the faster the gun must be moved to prevent sags and runs. Holding the gun too far from the work will cause excessive fog, overspray, and a thin and grainy coat.

Do not wave the spray gun. This waving is called arching. Instead, hold the spray gun at a 12 to 15 inch distance perpendicular from the work.

# SPRAY TECHNIQUE continued

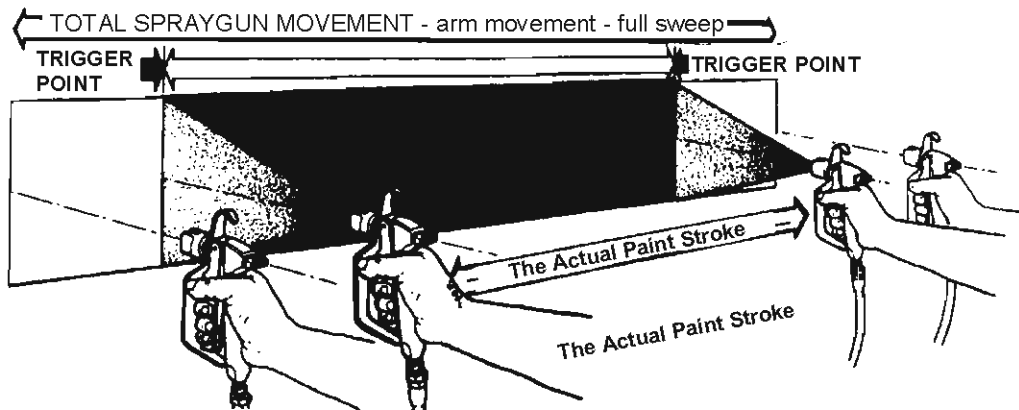

It is important to "trigger" the gun after gun movement (arm movement) has started and release trigger (shut gun off) before gun movement ends. Gun movement is always longer than actual paint (spray) stroke. In that manner, even blending and uniform paint coat thickness is achieved over the entire surface. When the gun is in motion as the trigger is pulled, it deposits an even amount of paint.

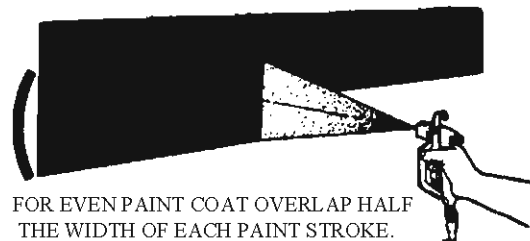

Overlap the previous pass by half the width of the spray pattern. Aim at the bottom of the previous pass.

Spray with uniform strokes from left to right and from right to left, holding stroke speed, distance, lapping, and triggering as uniform as possible.

## TAILING

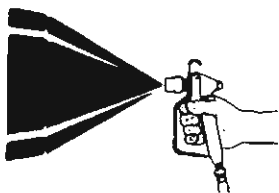

Adjust pressure control knob so that paint is completely atomized from the spray gun. Insufficient pressure will result in "tailing".

## GOOD PATTERN

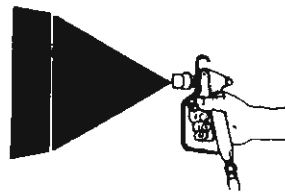

## FOG, OVERSPRAY

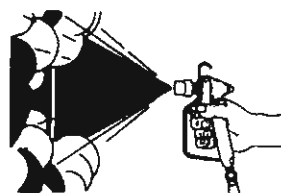

Too much pressure will result in excess fog and overspray, excessive tip wear, and increased sprayer wear and tear.

## POOR PATTERN GOOD PATTERN

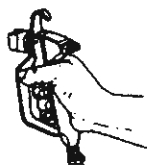

Always use the lowest pressure possible to obtain desirable results.

Test the spray pattern on a piece of cardboard or other surface.

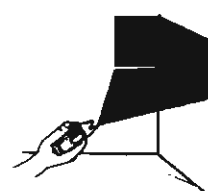

INSIDE CORNER

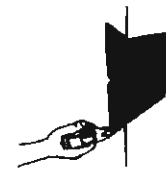

OUTSIDE CORNER

"Inside" and "outside" corners can be sprayed.

Aim the spray gun toward the center of the corner. The spray pattern is divided in half, and the edges of the spray pattern on both walls are the same.

# AIRLESSCO 007 X & 007XL SPRAY GUN

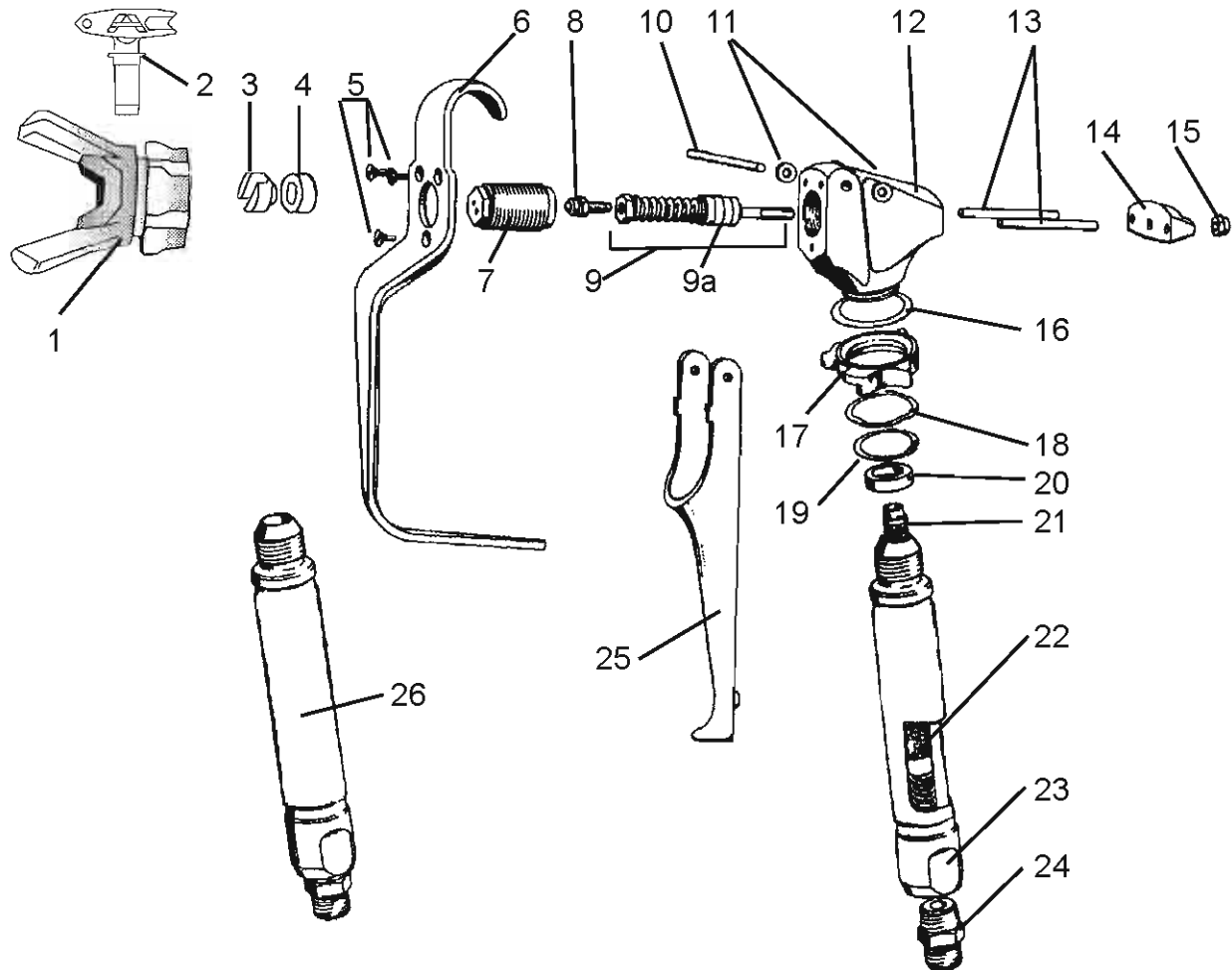

| Item No. | Part No. | Description            | Item No. | Part No.  | Description                  |
|----------|----------|------------------------|----------|-----------|------------------------------|
| 1        | 561-001  | Rev-Guard              | 15       | 120-021   | Nut                          |
| 2        | 560-xxx  | Rev-Tip                | 16       | 120-056   | Washer                       |
| 3        | 561-025  | Rev-Tip Seal-metal     | 17       | 120-048   | Safety Latch or Trigger Lock |
| 4        | 561-026  | Rev-Tip Seal-O-ring    | 18       | 120-055   | Wave Washer                  |
| 5        | 120-023  | Screw (3)              | 19       | 120-049   | Retaining Ring               |
| 6        | 120-005  | Guard                  | 20       | 120-082   | Seal                         |
| 7        | 120-035  | Valve Seat Complete    | 21       | 120-090CX | Filter-Complete-Coarse       |
| 8        | 120-037  | Valve Ball with Holder | 21       | 120-090FX | Filter-Complete-Fine         |
| 9        | 120-011  | Valve Spring Unit      | 22       | 120-088   | Spring                       |
| 9a       | 120-033  | Seals Teflon (2)       | 23       | 120-087   | Handle Complete 007X         |
| 10       | 120-022  | Trigger Pin            | 24       | 115-019   | Connector                    |
| 11       | 120-046  | Washer (2)             | 25       | 120-044   | Trigger                      |
| 12       | 120-002  | Gun Head               | 26       | 120-085   | Handle with Swivel 007XL     |
| 13       | 120-045  | Retainer Pin (2)       |          |           |                              |
| 14       | 120-020  | Retainer               |          |           |                              |

# AIRLESSCO 007X & 007XL SPRAY GUN

Attach spray gun to hose and tighten fittings securely. Set the gun trigger lock (Also may be called gun safety latch) The gun trigger lock should always be set when the gun is not being triggered.

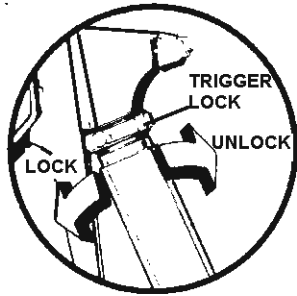

## ADJUSTING SPRAY GUN

Hold gun with trigger locked (25) and push trigger against the lock (17). Then adjust nut (15) so that the retainer (14) will move freely back and forth approximately 1/32" to allow valve spring unit (9) to seat the valve ball (8).

**IMPORTANT:** Readjust nut (15) periodically for wear of valve seat (7) and valve ball (8); otherwise, leakage will occur.

## TO REPLACE THE VALVE BALL HOLDER (8)

**KIT #2-007**

3 Tip Washers                      1 Valve Seat (7)  
1 Valve Ball Holder (8)    2 Seals-Teflon (9a)

### Dismantling:

1. Unscrew Rev-Guard and remove spray tip and seal.
2. Unscrew valve seat (7) with 1/2" socket wrench.

#### **\*Caution\***

When removing and replacing valve seat (7), hold the trigger (25) in the open position so that the valve ball (8) is lifted off the valve seat. Failure to lift the ball off the seat will result in a scratched leaky valve.

3. Unscrew valve ball (8) together with the brass part of the assembly (9). Do not pull on the parts or the packing may get damaged.
4. Unscrew the valve ball (8) from the brass part of the assembly (9).

**Reassembling** is done in reverse sequence. Screw the new valve ball with holder (8) into the brass part (9).

#### **\*Caution\***

Tighten valve ball and brass part on threaded end of the shaft by hand until you feel a positive stop. Do not tighten with a wrench since this could result in breaking the shaft.

Note it is recommended that you change the valve seat (7) and valve ball (8) at the same time.

## REPLACING THE VALVE SPRING UNIT (9)

**KIT#3-007**

3 Tip Washers                      1 Valve Seat (7)  
1 Valve Ball Holder (8)    1 Valve Spring Unit (9)

1. Repeat dismantling procedure as outlined above under Steps 1 through 3.
2. Unscrew nut (15), remove retainer (14) with retainer pins (13) and push shaft of the valve spring unit (9) out of the gun head (12).
3. Clean gun head (12) bore with solvent and small brush. Do not use any sharp objects to scrape away dried paint, as they would cause leakage around the seal.

**Reassembling** is done in reverse sequence. **IMPORTANT:** When reassembling, install valve spring unit (9) with spring loose.

Push firmly into gun head by hand. Install retainer pins (13), retainer (14) and nut (15) loosely onto valve spring unit (9). By hand turn front of valve spring unit clockwise, tightening the valve spring unit until you feel a positive stop. At that point, continue tightening the valve spring another 1/8 turn expanding the Teflon seals against body of gun.

#### **\*Caution\***

Do not tighten beyond 1/8 turn as this can result in breaking the valve spring unit shaft. Continue reassembly and adjustment as described above.

## CLEANING 007 SPRAY GUN

Immediately after the work is finished, flush the gun out with a solvent. Brush pins (13) with solvent and oil them lightly so they will not collect dried paint.

## TO REMOVE CLOGS- REVERSIBLE TIP

1. Lock gun trigger.
2. Turn Rev-Tip handle 180 degrees.
3. Disengage trigger lock and trigger gun into pail.
4. If the Rev-Tip handles appears locked (resists turning) loosen the retaining nut. Then handle will now turn easily.
5. Engage trigger lock and return handle to the spray position.

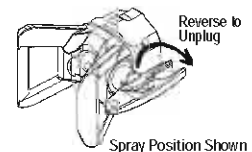

**CLOGGED FLAT TIP** -Should the spray tip become clogged, relieve pressure from hoses by following the "Pressure Relief Procedure" in Machine Manual, secure the gun with safety lock (17), take off Guard, take out the tip, soak in appropriate solvent & clean with a brush. (Do not use a needle or sharp pointed instrument to clean the tip. The tungsten carbide is brittle and can chip.)

## CLEANING FILTER

To clean the filter, use a brush dipped in as appropriate solvent. Change or clean filters at least once a day. Some types of latex may require a filter change after four hours of operation.



# REGULAR MAINTENANCE

1. Always stop the pump at the bottom of its stroke when you take a break or at the end of the day. This helps keep material from drying on the rod and damaging the packings.

2. Keep the displacement pump packing nut/wet cup 1/3 full of TSO (Throat Seal Oil) at all times. The TSO helps protect the packings and rod.

3. **Inspect the packing nut daily.** Your ProSpray pump has a patented "Triple Life Packing System". **Packing life will be extended a minimum**

**of 3 times if the following Packing Tightening Procedure is followed:**

Inspect the packing nut daily. If seepage of paint into the packing nut and/ or movement of the piston upward is found (while not spraying), the packing nut should be tightened enough to stop leakage only, but not any tighter.

**Overtightening will damage the packings** and reduce the packing life to the life of other piston pumps.

4. Lubricate Connecting Rod Pin every 3 months with SAE 30 W oil or annually with bearing grease.

# OIL AND LUBRICATION PROCEDURE

FIG. 8

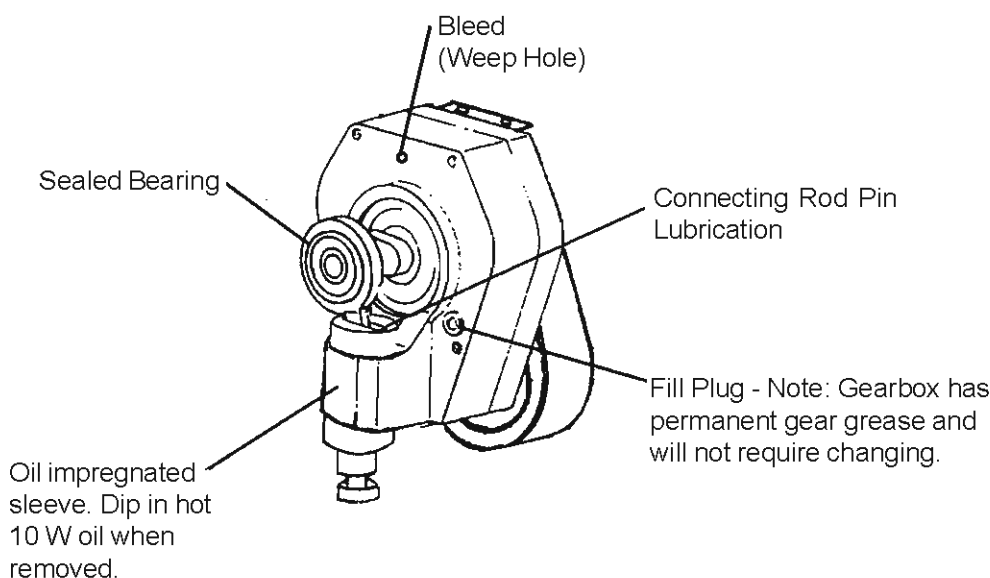

# TROUBLESHOOTING

| <u>PROBLEM</u>   | <u>CAUSE</u>   | <u>SOLUTION</u>   |
|--|--|---|
| There is spitting from the gun.                        | The fluid supply is low or empty.  | Refill the supply container.  |
|  | Air entrapped in the fluid pump or hose.   | Check for loose connections on the siphon assembly, tighten, then reprime pump.                         |
| Paint leaks into the wet cup                           | The packing nut/wet cup is loose.  | Tighten just enough to stop leakage.  |
|  | The upper packings are worn or damaged.<br>Worn Piston Rod.  | Replace the packings. See page 18.<br>Replace Piston Rod  |
| The engine operates, but the paint pump doesn't cycle. | The pressure setting is too low.<br>The clutch is not engaged.<br>The displacement pump is seized. | Increase the pressure. See page 3.<br>See Troubleshooting pg. 20.<br>Service the pump. See pgs. 17 & 18 |

| <b><u>PROBLEM</u></b>  | <b><u>CAUSE</u></b>  | <b><u>SOLUTION</u></b>   |
|--|--|--|
| The engine and displacement pump operates, but paint pressure is too low or none             | The pressure setting is too low.<br>The tip or gun filter is clogged.<br>The tip is worn.<br>The fluid displacement pump filter is clogged.<br>There is a large pressure drop in the fluid hose. | Increase the pressure, see page 3.<br>Remove the tip and/or filter and clean them.<br>Replace Tip.<br>Clean the filter.<br><br>Use a larger diameter hose. |
| The displacement pump operates, but the output is too low on the downstroke or both strokes. | The lower check valve ball is not seating properly.  | Service the lower check valve see page 17.   |
| The displacement pump operates, but the output is too low on the upstroke.                   | The upper check valve ball is not seating properly.<br><br>The lower packings are worn or damaged.   | Service the upper check valve per page 17.<br><br>Replace the packings. See page 18.   |
| Clutch does not engage.<br>Clutch slippage.  |  | See Troubleshooting page 20.<br>Call Authorized Service Center.  |
| Engine stops   |  | Refer to Engine Manual.  |

## **SERVICING FLUID PUMP**

Note: Check everything in the Troubleshooting Chart before disassembling the sprayer.

### **FLUID PUMP DISCONNECT**

1. Flush out the material you are spraying, if possible.
2. Follow the Pressure Relief Procedure on Page 6. Stop the pump in the middle of down stroke.
3. Remove the suction tube and fluid hose (if so equipped) from the fluid pump.
4. Remove 2 retaining rings and slip the sleeve of the coupling down and remove both coupling halves. This will disconnect fluid pump from the connecting rod.
5. Unscrew the two tie rod locknuts.
6. Pull the pump off the tie rods.

### **FLUID PUMP REINSTALL**

1. Loosen the packing nut and extend piston rod to fully up position. Slip sleeve (189-047) over the piston rod.
2. Make sure that spacer tubes (301-048) are in place.
3. Connect connecting rod with fluid pump by installing coupling halves (189-046). Slide sleeve over coupling halves. Secure with retaining ring (189-048).
4. Secure the fluid pump housing to the tie rods (100-328) and screw locknuts with washers on loosely.
5. Tighten the tie rod locknuts evenly to 30 ft. lb.
6. Reconnect fluid hose and suction tube (if so equipped).

**NOTE: After all the rod locknuts are tight, the alignment of both rods should allow easy assembly and disassembly of the coupling. If any binding, loosen and retighten all the rod locknuts to improve the alignment. Misalignment causes premature wear of seal and packings.**

7. Tighten the packing nut, until there is resistance, then 1 full turn tighter. Approximately 4 threads will show, when new packings are installed. Fill the wet cup of the packing nut 1/3 full with TSO.
8. Start the pump and operate it slowly (at low engine speed and pressure setting ) to check the piston rod for binding. Adjust tie rod lock nuts if necessary to eliminate binding.
9. Run at maximum pressure for several minutes, relieve pressure and repeat step 7.

# SERVICING UPPER AND LOWER CHECK VALVES

## LOWER CHECK VALVE (SEE FIG. 9 & 11)

1. Screw the lower check valve nut (187-018) out of the pump housing (187-313) containing intake seat support (187-017).
2. Remove the intake seat (187-065), "O" ring (187-034), intake ball (187-020) and retainer (187-016).
3. Clean all parts and inspect them for wear or damage, replacing parts as needed. Old "O" rings should be replaced with new ones

Note: "O"ring PN 187-028 is available in the following materials: Viton for waterbase paint - letter "V" after part no. Teflon for other fluids - letter "T" after part no.

4. Clean inside of pump housing (187-313).
5. Reassemble the valve and screw it onto the pump housing if no further pump service is needed.

## PISTON-ROD, UPPER CHECK VALVE

### (SEE FIG. 22, pg 28)

1. Stop piston rod in middle of it's stroke. Remove retaining rings (189-048).
2. Slip the sleeve (189-047) off the coupling halves (189-046) and remove both coupling halves. This will disconnect piston rod from pump drive.
3. Screw the lower check valve nut (187-018) off the pump and remove lower check valve.
4. Disconnect the fluid hose from the round manifold.
5. Loosen the packing nut and push the piston rod down and out of the housing.
6. Place rod holder Part No. 187-248 in a vise. Slide the rod into the holder and lock in place with a 1/4" pin. Push the pin through the holder and the rod. Using a 7/16" Allen wrench, screw the seat support (187-021) out of rod, remove "O"ring (187-033T), seat (187-044) and ball (115-022) out of the piston rod (187-311).

**NOTE:** Retainer (187-032) with "O"ring (187-033V) and ball stop (187-022) may remain in the piston rod. Clean and check visually the ball stop (187-022) for excessive wear. If ball stop needs to be replaced, install any screw with thread 1/2-13NC into the threaded hole of retainer (187-032) and pull straight out.

7. Clean all parts and inspect them carefully for wear or damage. Inspect the outside of the piston rod for scoring or wear. Replace these parts if needed. A worn piston rod will cause premature wear of packings.
8. Install parts back into piston rod as per Fig. 11, pg. 19 VIEW A as shown.

Note: Before installing discharge seat support (187-021), place two drops of loctite No. 242 (blue) on threads before assembling.

9. After installation and tightening of discharge seat support, check to ensure ball stop (PN 187-022) is properly installed in piston rod and has not fallen into piston bore. Check by pushing on the ball and feeling a positive stop against the ball stop

FIG. 9

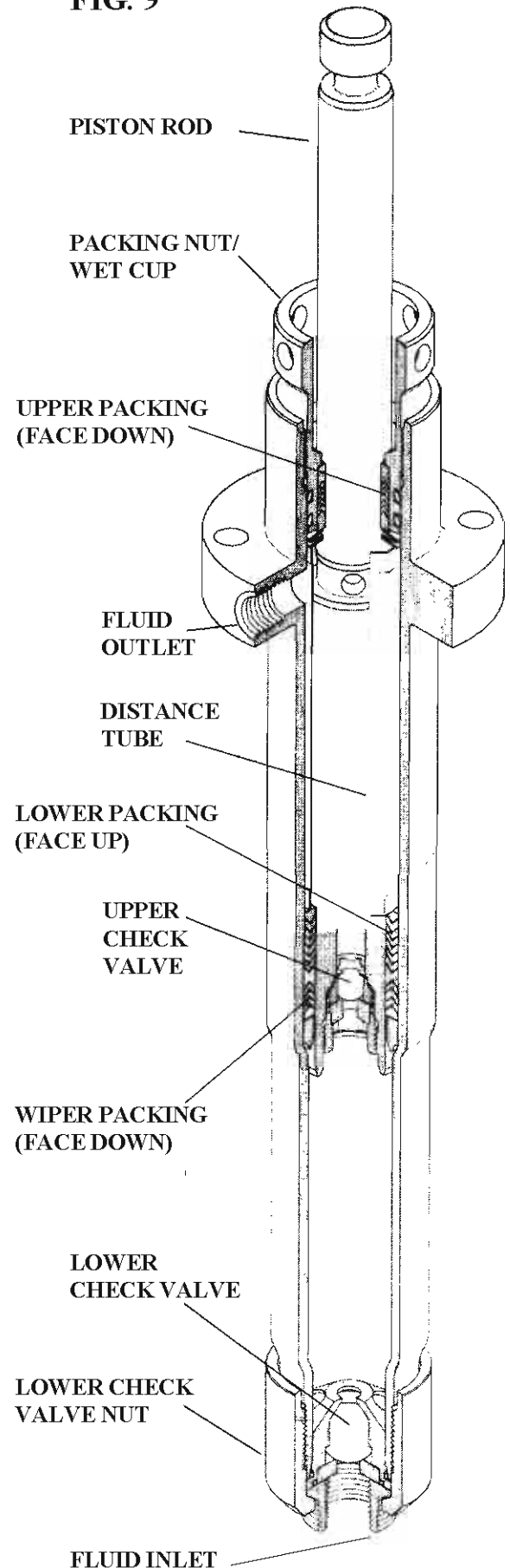

# V-PACKING REPLACEMENT

## V-PACKING REPLACEMENT KIT SEVERE DUTY- PART NO. 187-040

**Contains:** Leather & Plastic Packings, Teflon & Viton O-Rings, Balls & Upper Ball Stop & plastic dual sided female adaptor & Large Plastic Male Glands.

## V-PACKING REPLACEMENT KIT -ALL TEFLON - PN 187-042 GLAND KIT - PN 187-064

## V-PACKING REPLACEMENT INSTRUCTIONS

1. Remove the fluid pump as per the "Fluid Pump Disconnect" instructions on page 16.
  2. Unscrew and remove the lower check valve per instructions on page 17.
  3. Unscrew & remove the packing nut (187-046). Push the piston rod down through the packings and out of the pump. Wrap some masking tape around the bottom of the piston. Now push the piston back through the pump and remove through the top. The packings and glands will be removed with the piston rod, leaving the pump body (187-313) empty. Utilizing tool (PN 187-249) the complete packing set can be removed quickly and easily.
  4. Disassemble and clean all parts for reassembly. Discard old packings and lower glands. Save upper glands (187-026 & 187-025) for reuse.
- ### PISTON ROD, UPPER CHECK VALVE
5. Hold piston rod in a vise, using the special block (PN 187-248) and pin (PN 187-250) tools.
  6. Use a 7/16" allen wrench to remove the discharge seat support (PN 187-021) from the piston rod.
  7. Pull out the discharge seat, gasket and upper ball from the piston rod.
  8. Screw in a 3/8" bolt into the discharge retainer and extract the retainer with O-Ring attached. The discharge ball stop will fall out of the piston rod once the retainer is removed.
  9. Clean all parts, replace O-rings and ball stop and reassemble as per drawing above. Note: before installing discharge seat support (187-021) place two drops of loctite (blue) No. 242 on threads before assembling.
  10. After installation & tightening of discharge seat support, check to ensure ball stop (PN 187-022) is properly installed in piston & has not fallen into the piston bore. Check by pushing on the ball & feeling a positive stop against the ball stop (PN 187-022).

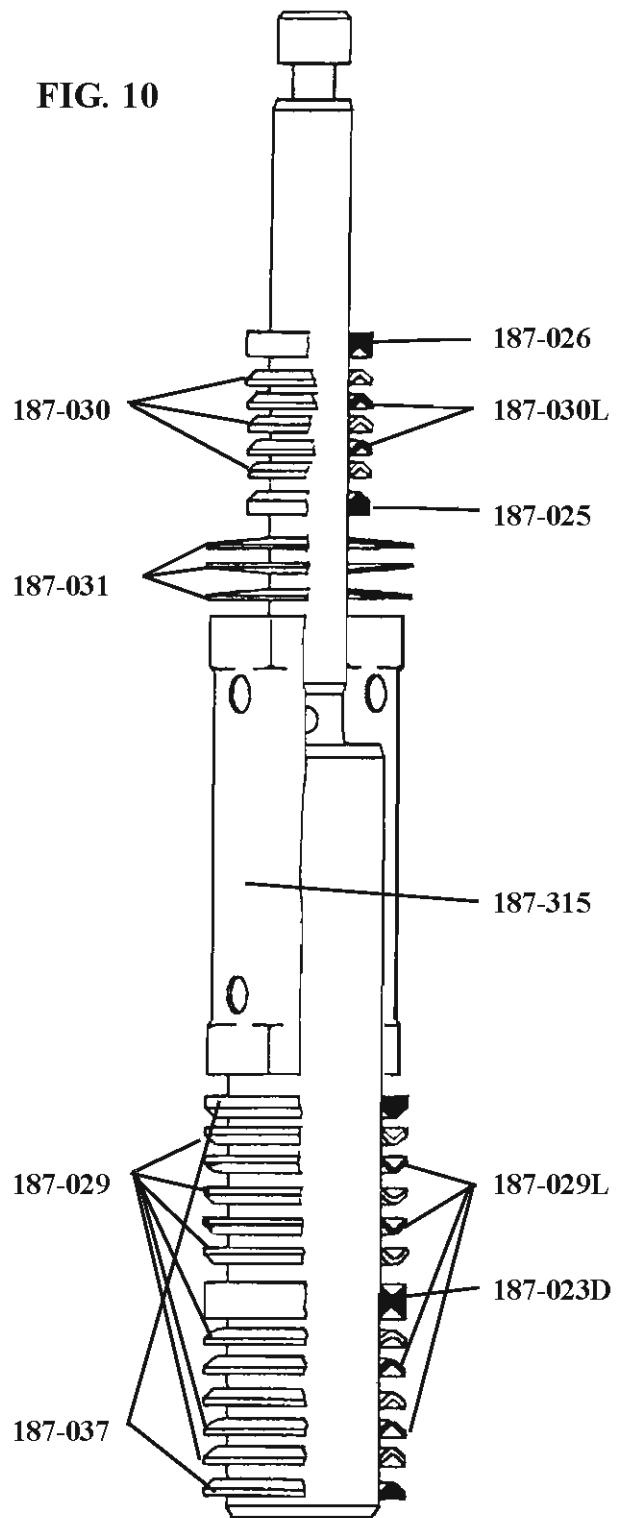

REASSEMBLY CONTINUED ON PAGE 19

# FLUID PUMP - 187-310

FIG. 11

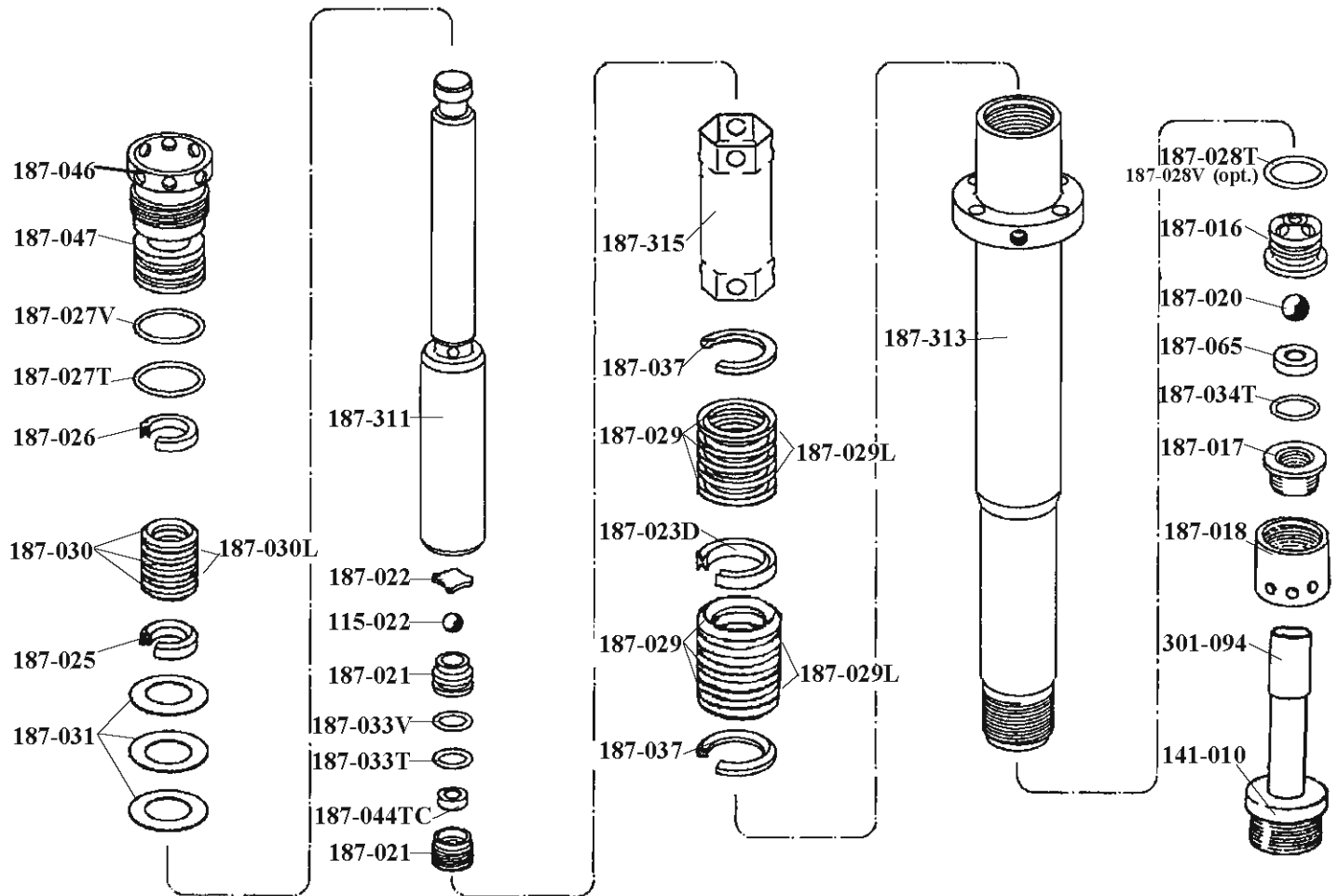

## REASSEMBLY

11. Lubricate leather packings in lightweight oil for 10 minutes prior to assembly.
12. Remove masking tape from piston. (if used)
13. Reassemble all parts onto piston in the following order:
  - a. Start with lower male gland (187-037)
  - b. Five V-Packings (187-029 & 187-029L). "V" inverted.
  - c. Female adaptor (187-023D)
  - d. Five V-Packings (187-029 & 187-029L). "V" up.
  - e. Upper Male gland (187-037)
  - f. Slide on distance tube (187-315)
  - g. Three Belleville Springs (187-031) starting with the first spring facing down (∩) and next facing up (∪) and the third facing down (∩).
  - h. Slide on upper male gland (187-025) with bevel facing up.
  - i. Five V-Packings (187-029 & 187-029L). "V" inverted.
  - j. Female Gland (187-026)
  - k. Slide on the V-Packing holder (187-047) and Orings (187-027V & 187-027T) over upper packings.
14. Lubricate inside of cylinder & outside of packings, then slide complete assembly into the pump casing (187-313). Thread packing nut (187-046) into cylinder and tighten handtight.
15. Install the lower check valve and tighten the lower check valve nut (187-018).
16. Connect the pump to the machine as per fluid pump reinstall procedure on page 16.
17. Tighten the packing nut (clockwise) until resistance is felt against the belleville springs. Now turn it 1 turn clockwise. Approximately four threads will show on the packing nut. Run unit to maximum pressure for 10 minutes, relieve pressure and repeat packing nut adjustment.

# BALL VALVE - PART NO. 100-119

FIG. 12

| PARTS LIST - FIG.12 |          |             |
|---------------------|----------|-------------|
| ITEM NO.            | PART NO. | DESCRIPTION |
| 1                   | 100-162  | Handle      |
| 2                   | 100-163  | Screw       |
| 3                   | 100-164  | Ball        |
| *                   | KIT-119  | Repair Kit  |

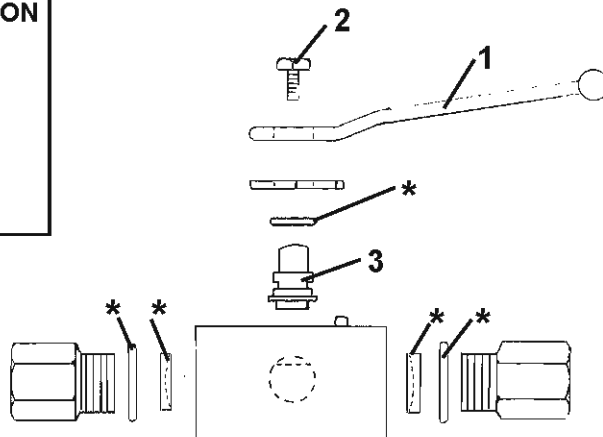

## TROUBLESHOOTING - CLUTCH DOES NOT ENGAGE

**STEP 1:** Ensure that the pressure control knob (POT) is in the maximum (CW) position.

**STEP 2:** Remove the upper and lower clutch and electrical covers.

**STEP 3:** Check all electrical connections between the engine magneto, sensor, control board and clutch for loose connections or damaged leads. See Fig. 13.

**STEP 4:** Disconnect the two leads from the control board (blue) and the clutch assembly (black). Using a multimeter, with the engine at maximum RPM, pressure control knob in the maximum position and the prime valve open (priming) position, test the DC voltage across the boards leads. This voltage must be 13-14 VDC. If the readings are correct, the board, sensor and magneto are okay and the problem is the clutch assembly. If this is the case, proceed to Step 5. If the voltage is outside this range go to Step 8.

**STEP 5:** Measure resistance between the clutch leads (blue). This value must be 10-16 ohms. If this readings is out of specifications the clutch is defective and must be replaced, otherwise continue troubleshooting.

**STEP 6:** If the clutch resistance readings of Step 5 and 6 are correct, check the spacing between the clutch field and plate. The gap must be approximately .028" . If this gap is too wide, try to tighten the differential screw and coupler on the gearbox shaft. Should the clutch still not engage, replace the clutch assembly.

**STEP 7:** When the DC voltage from the board is not 13-14 VDC, disconnect the control board lead (black) from the engine magneto lead (pink), located on the side of the engine. With the engine at maximum RPM, pressure control knob in maximum (CW) position and prime valve open (priming), read the AC voltage from the magneto lead to the sprayer frame. This reading should be 11-30 VAC. If outside this range, contact your local Honda repair facility for magneto replacement. If the magneto is producing the proper AC voltage, continue to Step 9.

**STEP 8:** Test the sensor by reading the resistance between the red and black wires. The resistance runs between 1.8-3.5 kohms. A defective sensor usually shows no resistance (open). If the reading is outside standards, replace the sensor. An alternative method to test the sensor, is to plug a new sensor into the board and see if the clutch will engage. Caution! When using this method, turn the machine off just as soon as the clutch engages. This is important because the sensor plugged into the board is not measuring pressure in the fluid section. The machine can extreme pressure if not immediately turned off.

**STEP 9:** When Steps 1-9 have been completed and all other possibilities have been exhausted and the electrical control board is the only item left, replace the board. See page 21.

## REPLACEMENT OF ELECTRICAL CONTROL BOARD

1. Remove electrical cover.
2. Disconnect sensor lead from Electrical Board.
3. Disconnect two clutch leads on Electrical Board from leads on clutch.
4. Disconnect the Electrical Board Green "Ground" lead from frame, if so equipped.
5. Using a 1/16" allen, loosen set screw in Pressure Control Knob and remove knob.
6. Using a 1/2" nutdriver or 1/2" deep socket, remove nut from pressure control shaft. This will allow removal of electrical control board from frame.
7. Replace Electrical Board Assembly in reverse order. Adjust pressure as per procedure below, "Pressure Calibration on the Electrical Control Board".

## PRESSURE CALIBRATION ON THE ELECTRICAL CONTROL BOARD

1. Turn "Pressure Calibration" Trimpot adjustment on electrical control board in the counter clockwise direction at least 15 revolutions.
2. Connect 5000 psi glycerine pressure guage on output of pump between hose and gun to monitor Fluid Pump Pressure.
3. Start engine and run at maximum RPM. Turn Prime/Pressure Relief Valve to the open (Prime) position. Turn Pressure Control Knob to maximum position (fully clockwise).
4. Using an insulated screwdriver, adjust "Pressure Calibration" Trimpot by turning clockwise until the clutch engages. When the clutch engages the pump will commence Priming. When pump is primed, turn the Prime/Pressure Relief Valve to the Closed (Pressure) Position. The pump will begin to pressurize and the clutch will disengage at a low pressure. Continue turning the Trimpot clockwise to increase pressure to 3000 psi.
5. Trigger gun. The pressure should drop approximately 350-400 psi (when using a 3/8" hose), the clutch will engage and build pressure to 3000 psi and disengage. Trigger gun several times to ensure proper pressure setting.
6. Turn Pressure Control Knob to minimum position. The clutch should disengage and pump stop moving.
7. Secure leads with tie strap.
8. Replace cover on unit. Ensure the leads are not pinched or damaged in the process of replacing covers.

FIG.

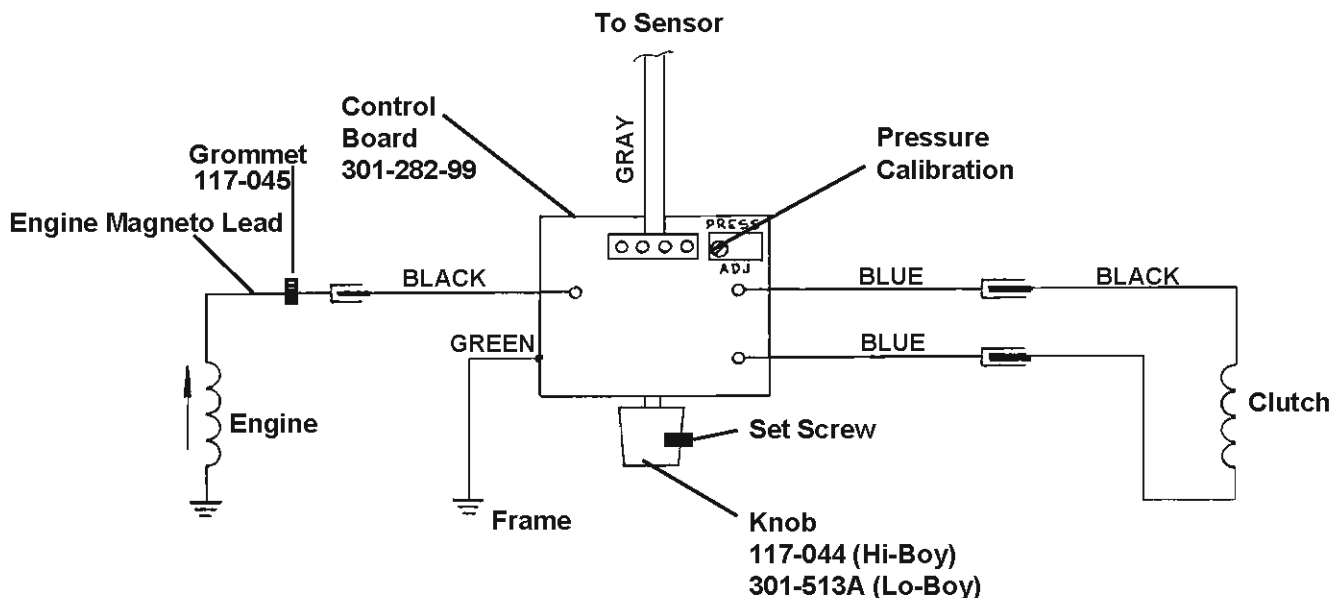

# CLUTCH REPLACEMENT - HI-BOY

## REMOVE CLUTCH AS FOLLOWS:

(See Figs. 15 & 17)

1. Remove upper and lower clutch covers and electrical cover.
2. Disconnect two clutch leads from electrical board leads. Pull clutch leads through grommet from frame.
3. Disconnect and remove fluid section from gearbox, including connecting rod assembly and cover plate.
4. Remove four bolts, Item 7 (Fig. 17), holding gearbox and clutch assembly to holder, Item 6. Remove gearbox with clutch assembly attached.

5. Place gearbox in vice by gripping the flat portion of the drive crank allowing the clutch assembly to face up. Use caution and not allow Gearbox to swing and damage casting against vice.
6. Hold coupling screw, Item 2, Fig. 15 with 13/16" wrench, then with 5/16" allen wrench screw differential screw, Item 1, out of coupling screw and gearbox shaft.
7. Screw large end of differential screw (Item 1) into coupling screw (Item 2) and pull Item 2 out of clutch assembly.
8. The clutch, Item 5, can now be removed. Items 3 - 8 should be inspected for wear, replace if needed.

## INSTALL NEW CLUTCH AS FOLLOWS:

1. With gearbox held as described above, place first spacer, Item 8 and bearing, Item 6 onto gearbox shaft. (See Fig. 15)
2. Insert snap rings (2), Item 7, into recesses of cog pulley portion of clutch. Place cog pulley portion of clutch onto shaft.
3. Place second spacer, Item 8 into cog pulley portion of clutch. This spacer will rest on the first bearing, Item 6 installed.
4. Insert second bearing, Item 6, on top of upper snap ring, Item 5.
5. Lay removable spacer (Item 4) on top of last bearing. If the clutch air gap is larger than .028", do not use removable spacer. Put spacer (Item 3) over removable spacer, if used, and top bearing.
6. Place coil portion of clutch down onto cog pulley portion of clutch and center on gearbox shaft.
7. Screw differential screw, Item 1 into coupling nut assembly until 1/16" is showing. (See Fig. 16).
8. Push coupling nut assembly, Item 2, into clutch assembly until it comes to a positive stop. (Differential screw comes into contact with the threaded gearbox shaft.)

9. With 13/16" wrench on coupling screw and 5/16" allen wrench in the differential screw, simultaneously screw coupling assembly into gearbox shaft by turning clockwise until a positive stop is reached.
10. Hold coupling screw and tighten differential screw to 30 ft-lbs. This will expand the coupling assembly, thereby holding the clutch assembly to gearbox shaft. Turn clutch observing a gap of approximately 1/36" between two clutch surfaces.
11. Reconnect gearbox and clutch assembly to holder with four bolts as follows: Place cog belt on large pulley portion of clutch. Hold belt and let gearbox hang upside down. Place belt over upper pulley on engine, Item 3, Fig. 17. Rotate gearbox upright and install bolts loosely. Push down on gearbox with approximately 50 psi of force to tighten belt. Align gearbox vertically and tighten bolts.
12. Insert clutch leads back through grommet in frame and connect to electrical control board leads.
13. Connect spring, Item 9, Fig. 15, to holder, Item 6, Fig. 17.
14. Reconnect fluid section.
15. Check clutch and pump for proper operation. Replace covers.

## CLUTCH ASSEMBLY HI-BOY/LO-BOY PART NO. 301-284

FIG. 15

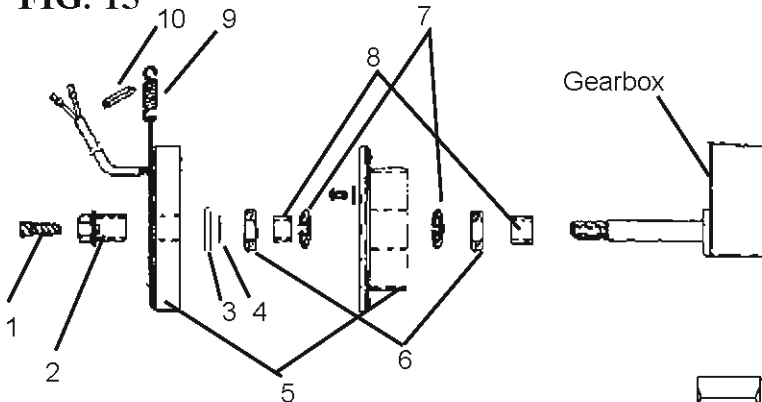

FIG. 16

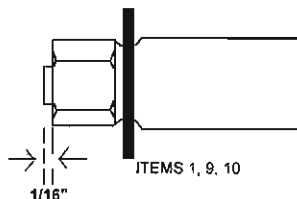

FIG. 15 PARTS LIST

| ITEM NO. | PART NO. | DESCRIPTION        |
|----------|----------|--------------------|
| 1        | 112-041  | Screw-Differential |
| 2        | 112-054  | Coupling Nut Assy  |
| 3        | 301-412  | Spacer             |
| 4        | 301-413  | Spacer-Removable   |
| 5        | 301-264  | Clutch-Replacement |
| 6        | 301-037  | Bearing (2)        |
| 7        | 100-333  | Retaining Ring (2) |
| 8        | 301-274  | Spacer (2)         |
| 9        | 136-068  | Spring             |
| 10       | 301-316  | Rubber Edge        |



# CLUTCH REPLACEMENT - LO-BOY

## REMOVE CLUTCH AS FOLLOWS:

1. Remove the upper and lower clutch covers
2. Extract the splash cover from the clutch brackets and spacer tubes.
3. Disconnect the two clutch leads from the electrical control board leads.
4. Unscrew the whip hose from the manifold filter.
5. Remove the two nuts on the fluid section bracket and shock mounts.
6. Remove the four nuts away from gearbox (Fig. 24, Item 23) which pass through spacer tubes (Fig. 24, Item 15).
7. Pull the cog belt loose of the engine shaft cog pulley (Fig. 17, Item 3) and remove the gearbox/clutch assembly from the rest of the unit.
8. Place gearbox in vice by gripping the flat part of the drive crank allowing the clutch assembly to face up. Use caution and not allow gearbox to swing and damage casting against vice.
9. Hold coupling screw, with 13/16" wrench, then with 5/16" allen wrench, screw differential screw (Fig. 15, Item 1), out of coupling screw and gearbox shaft.
10. Screw large end of differential screw into coupling nut assembly (Fig. 15, Item 2) and pull out of clutch assembly.
11. The clutch (Fig. 15, Item 5) can now be removed. Fig. 15, Items 3-8 should be inspected for wear and replaced if needed.

## INSTALL NEW CLUTCH AS FOLLOWS:

1. With gearbox held as described above (Step 8), place first spacer, (Fig. 15, Item 8) and bearing, (Fig. 15, Item 6) onto gearbox shaft.
2. Insert snap rings (2), Item 7 into recesses of cog pulley portion of clutch. Place cog pulley portion of clutch with cog belt attached onto shaft.
3. Place second spacer, (Item 8) into cog pulley portion of clutch. This spacer will rest on the first bearing, (Item 6) installed.
4. Insert second bearing, (Item 6) on top of upper snap ring, (Item 7).
5. Lay removable spacer (Item 4) on top of last bearing. If the clutch air gap is larger than .028", do not use removable spacer. Put spacer (Item 3) over removable spacer, if used, and top bearing.
6. Place coil portion of clutch down onto cog pulley portion of clutch and center on gearbox shaft.
7. Screw differential screw, (Item 1) into coupling screw and nut until 1/16" is showing. (See Fig. 16)
8. Push coupling nut assembly, (Item 9) into clutch assembly until it comes to a positive stop. (Differential screw comes into contact with the threaded gearbox shaft.)
9. With 13/16" wrench on coupling screw and 5/16" allen wrench in differential screw, simultaneously screw coupling nut assembly into gearbox shaft by turning clockwise until a positive stop is reached.
10. Hold coupling nut ass'y and tighten differential screw to 30 ft.-lbs. This will expand the coupling assembly, thereby holding the clutch assembly to gearbox shaft. Turn clutch observing a gap of approximately .028" between two clutch surfaces.
11. Reinstall the gearbox/clutch assembly, by placing the fluid section bracket over the shock mount bolts.
12. Slip cog belt over the engine shaft cog pulley.
13. Re-assemble four studs, spacer tubes and nuts as before. Slightly loosen four screws (Fig. 14, Item 5).
14. Tighten set screws (Fig. 14, Item 6) until cog belt is properly tensioned, then tighten the four screws (Item 5).
15. Tighten the shock mount nuts.
16. Reattach the whip hose to the manifold filter.
17. Connect the clutch and board leads.
18. Replace the splash shield.
19. Test the clutch for proper operation.
20. Replace clutch covers.

FIG. 14

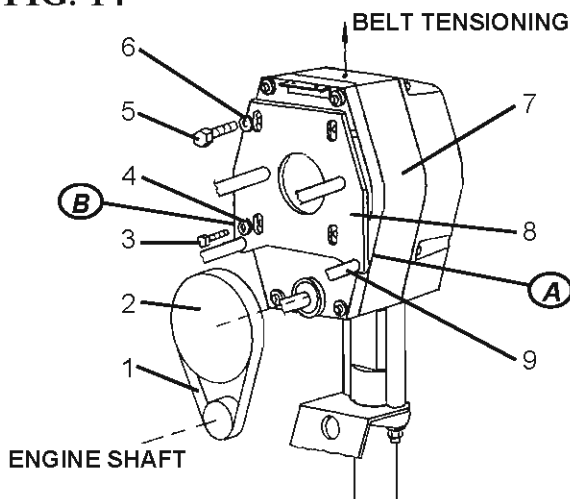

FIG 14 PARTS LIST

| ITEM NO. | PART NO. | DESCRIPTION     |
|----------|----------|-----------------|
| 1        | 301-231  | Belt            |
| 2        | 301-264  | Clutch          |
| 3        | 111-044  | Screw (2)       |
| 4        | 140-029  | Washer (2)      |
| 5        | 100-370  | Screw (2)       |
| 6        | 140-034  | Washer (2)      |
| 7        | 301-270  | Gearbox         |
| 8        | 305-045  | Plate           |
| 9        | 305-046  | Spacer Tube (4) |

# ENGINE ASSEMBLY HI-BOY - PART NO. 301-283

FIG. 17

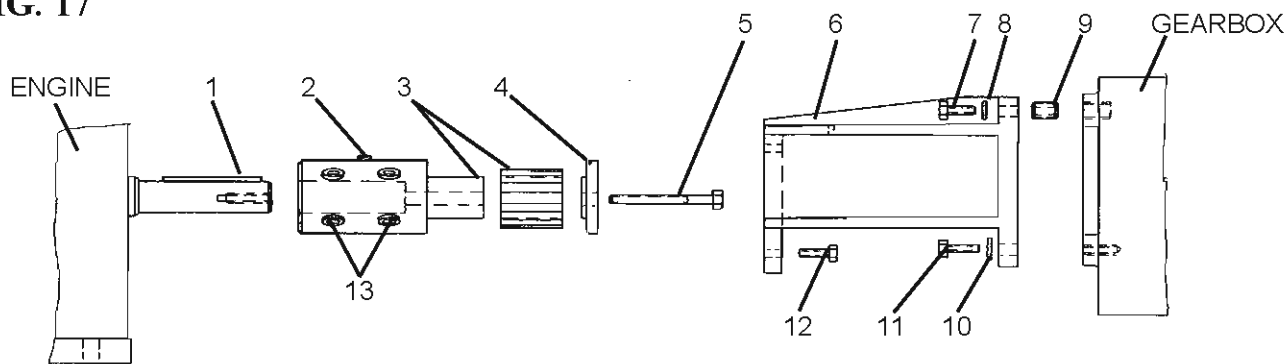

FIGURE 17 PARTS LIST, ENGINE ASS'Y (PN 301-283)

| ITEM NO. | PART NO. | DESCRIPTION                   | ITEM NO. | PART NO. | DESCRIPTION             |
|----------|----------|-------------------------------|----------|----------|-------------------------|
| 1        | 112-029  | Key (3/16 x 1 1/2)            | 8        | 140-034  | Washer, Flat 3/8 (2)    |
| 2        | 100-357  | Screw, Soc                    | 9        | 301-272  | Insert (2)              |
| 3        | 301-222A | Hub/Sheave Ass'y              | 10       | 140-029  | Washer, flat 5/16 (2)   |
| 4        | 301-229  | Plate                         | 11       | 111-044  | Screw, cap 5/16-18 (2)  |
| 5        | 301-230  | Screw Cap (5/16-24X 2 1/4)    | 12       | 100-392  | Screw, cap 5/16 - 2 (4) |
| 6        | 301-271  | Holder                        | 13       | 100-383  | Screw, soc 3/8 - 24 (4) |
| 7        | 100-370  | Screw, Cap (3/8 - 16 x 1) (2) |          |          |                         |

# ENGINE ASSEMBLY LO-BOY - PART NO. 301-524

FIG. 18

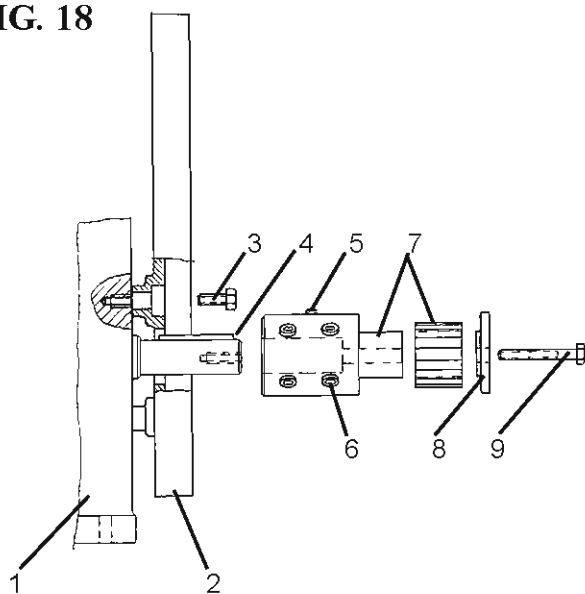

FIG. 18 PARTS LIST  
ENGINE ASS'Y (PN 301-524)

| ITEM NO. | PART NO. | DESCRIPTION        |
|----------|----------|--------------------|
| 1        | 301-160  | Honda 5.5HP Engine |
| 2        | 305-012  | Adaptor            |
| 3        | 100-392  | Screw (4)          |
| 4        | 112-029  | Key                |
| 5        | 100-357  | Screw              |
| 6        | 100-383  | Screw (4)          |
| 7        | 301-222A | Sheave             |
| 8        | 301-229  | Thrust Plate       |
| 9        | 301-230  | Screw              |

# PAINT SYSTEM ASSEMBLY -HI-BOY

## PART NO. 301-327

FIG. 19

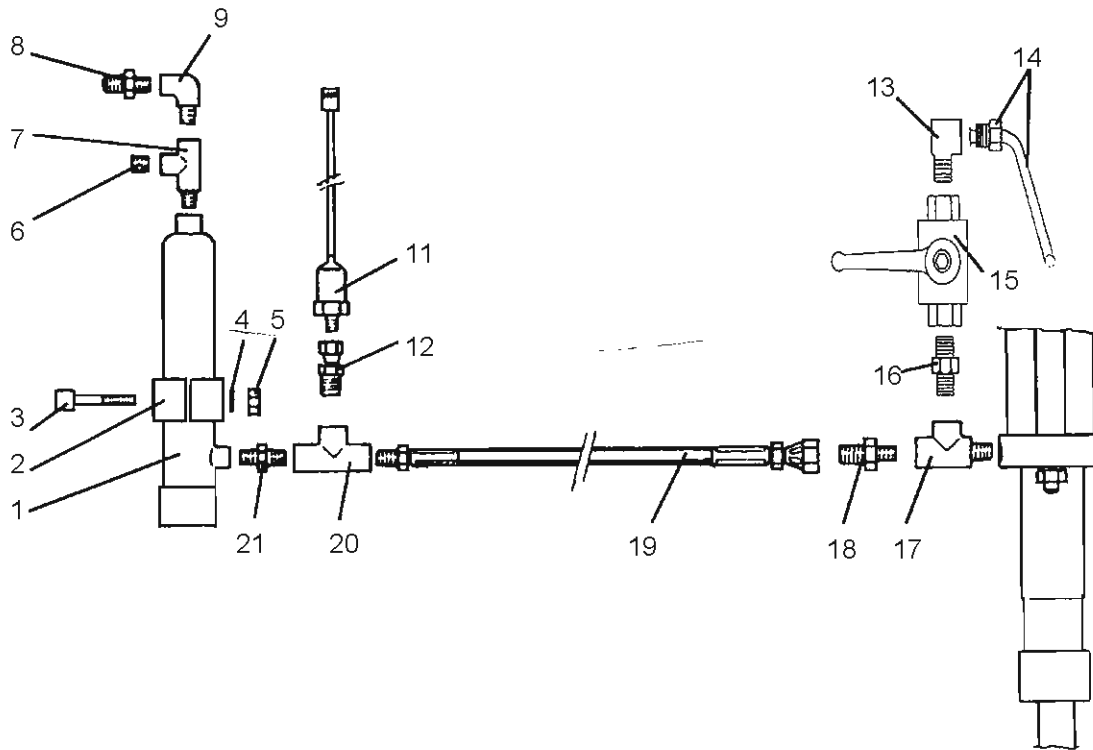

FIGURE 19 PARTS LIST

| ITEM NO. | PART NO. | DESCRIPTION               | ITEM NO. | PART NO. | DESCRIPTION               |
|----------|----------|---------------------------|----------|----------|---------------------------|
| 1        | 187-506  | Filter Ass'y              | 12       | 100-159  | Swivel, 3/8 NPT x 1/4 NPT |
| 2        | 136-210  | Clamp Set                 | 13       | 100-102  | 90 deg. Elbow, Flare      |
| 3        | 100-318  | Screw, HH,CAP 5/16-18 (2) | 14       | 301-215  | Return tube Ass'y         |
| 4        | 140--029 | Washer, flat, 5/16 (2)    | 15       | 100-119  | Ball Valve, 1/4 NPT       |
| 5        | 113-022  | Nut, Hex 5/16-18 (2)      | 16       | 100-070  | Nipple, 1/4 NPT           |
| 6        | 100-129  | Plug 3/8 NPT              | 17       | 100-115  | Tee, 1/4 NPT              |
| 7        | 100-134  | Tee Male, 3/8             | 18       | 100-109  | Hex Nipple 3/8 NPS x 1/4  |
| 8        | 100-034  | Hose Connector 3/8        | 19       | 301-257  | Hose 3/8 x 15.5 L         |
| 9        | 169-013  | Elbow 90 deg. 3/8 NPT     | 20       | 100-036  | Tee, 3/8 NPT              |
| 11       | 331-073A | Sensor Ass'y              | 21       | 169-010  | Nipple, 3/8 NPT           |

# PAINT SYSTEM ASSEMBLY-LO-BOY

FIG. 20

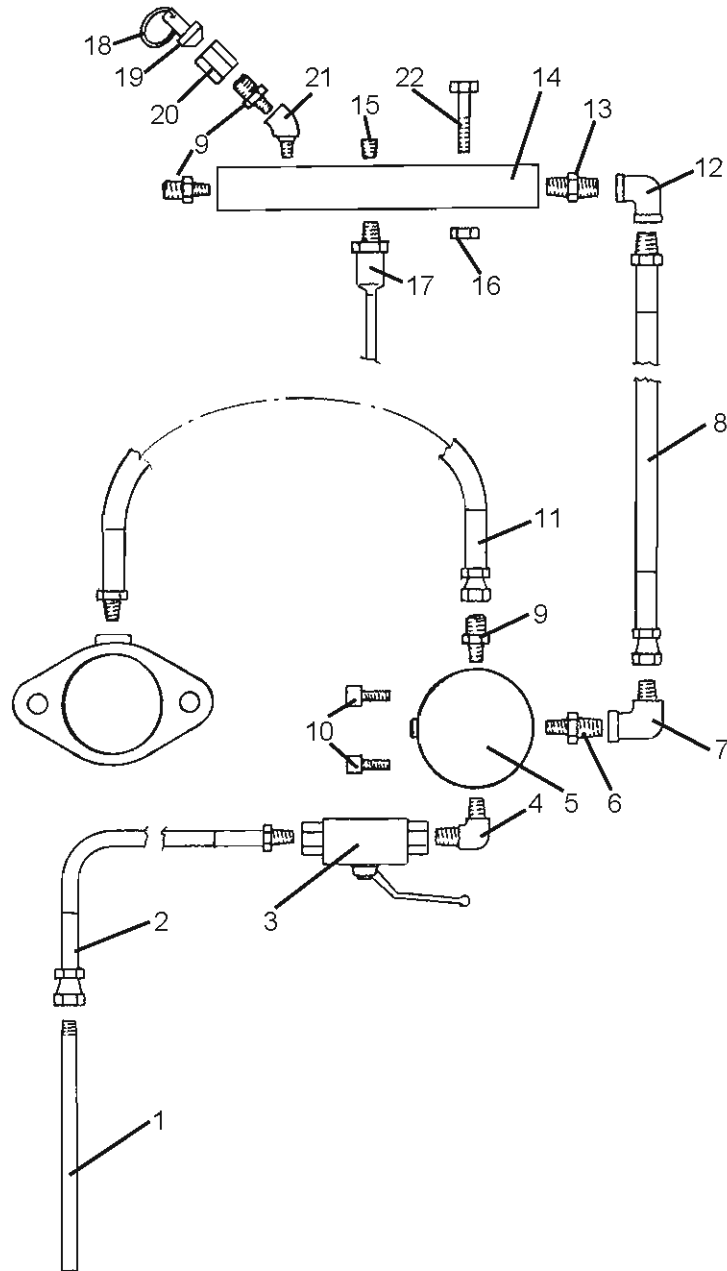
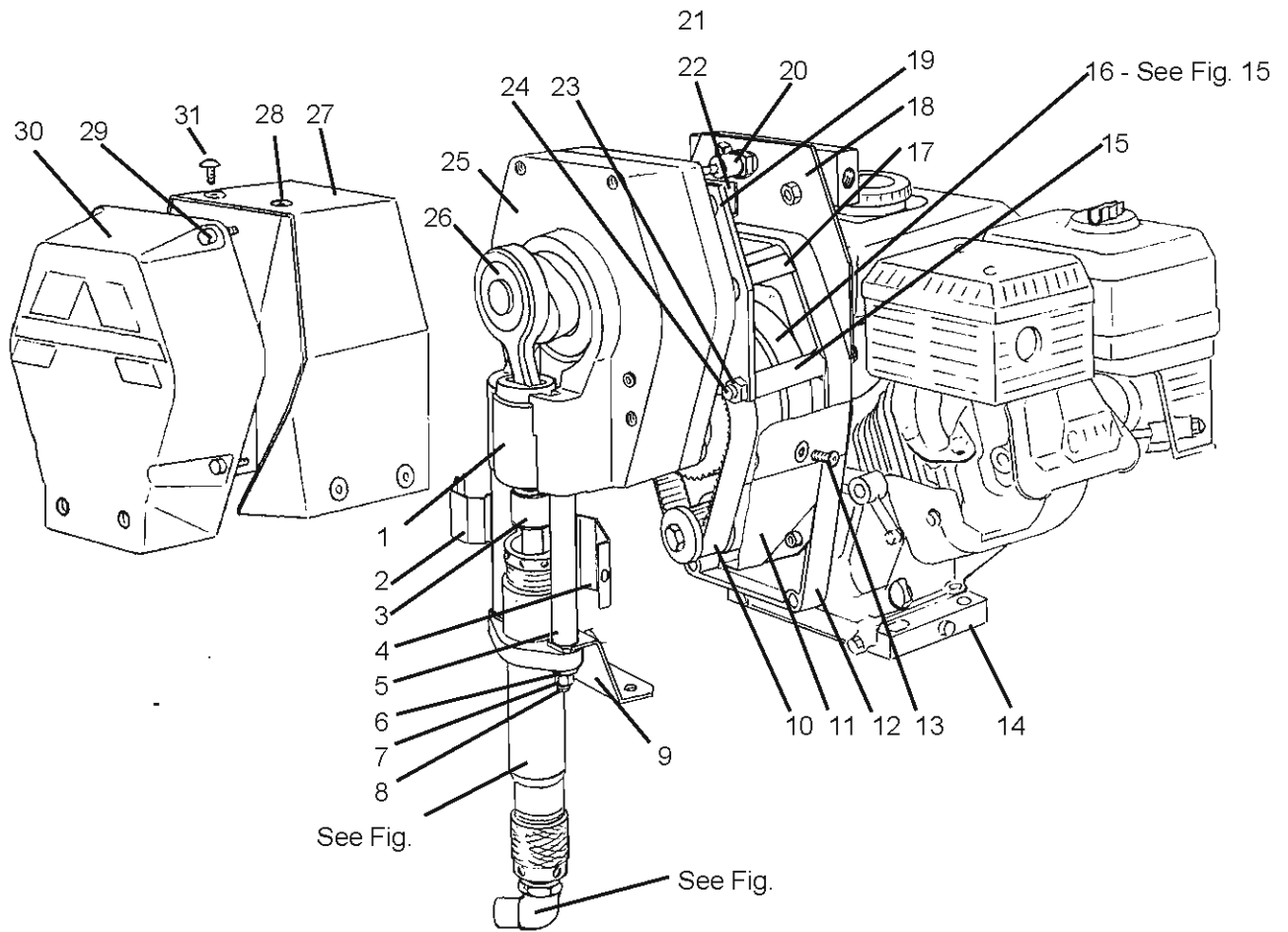

FIG. 20 PARTS LIST, PAINT SYSTEM ASSEMBLY

| ITEM NO. | PART NO. | DESCRIPTION | ITEM NO. | PART NO. | DESCRIPTION |
|----------|----------|-------------|----------|----------|-------------|
| 1        | 188-377  | Return Pipe | 12       | 100-171  | Elbow       |
| 2        | 100-012  | Whip        | 13       | 169-010  | Nipple      |
| 3        | 100-119  | Ball Valve  | 14       | 301-253  | Manifold    |
| 4        | 100-002  | Elbow       | 15       | 100-028  | Plug        |
| 5        | 301-360  | Maxi-Filter | 16       | 100-317  | Nut (2)     |
| 6        | 100-109  | Nipple      | 17       | 331-073A | Sensor      |
| 7        | 169-013  | Elbow       | 18       | 136-133  | Key Ring    |
| 8        | 100-123  | Hose        | 19       | 100-156  | Plug        |
| 9        | 100-033  | Connector   | 20       | 100-155  | Cap Nut     |
| 10       | 100-312  | Screw (2)   | 21       | 100-081A | Elbow       |
| 11       | 301-526  | Ball Valve  | 22       | 100-345  | Screw (2)   |

**FIG. 21**

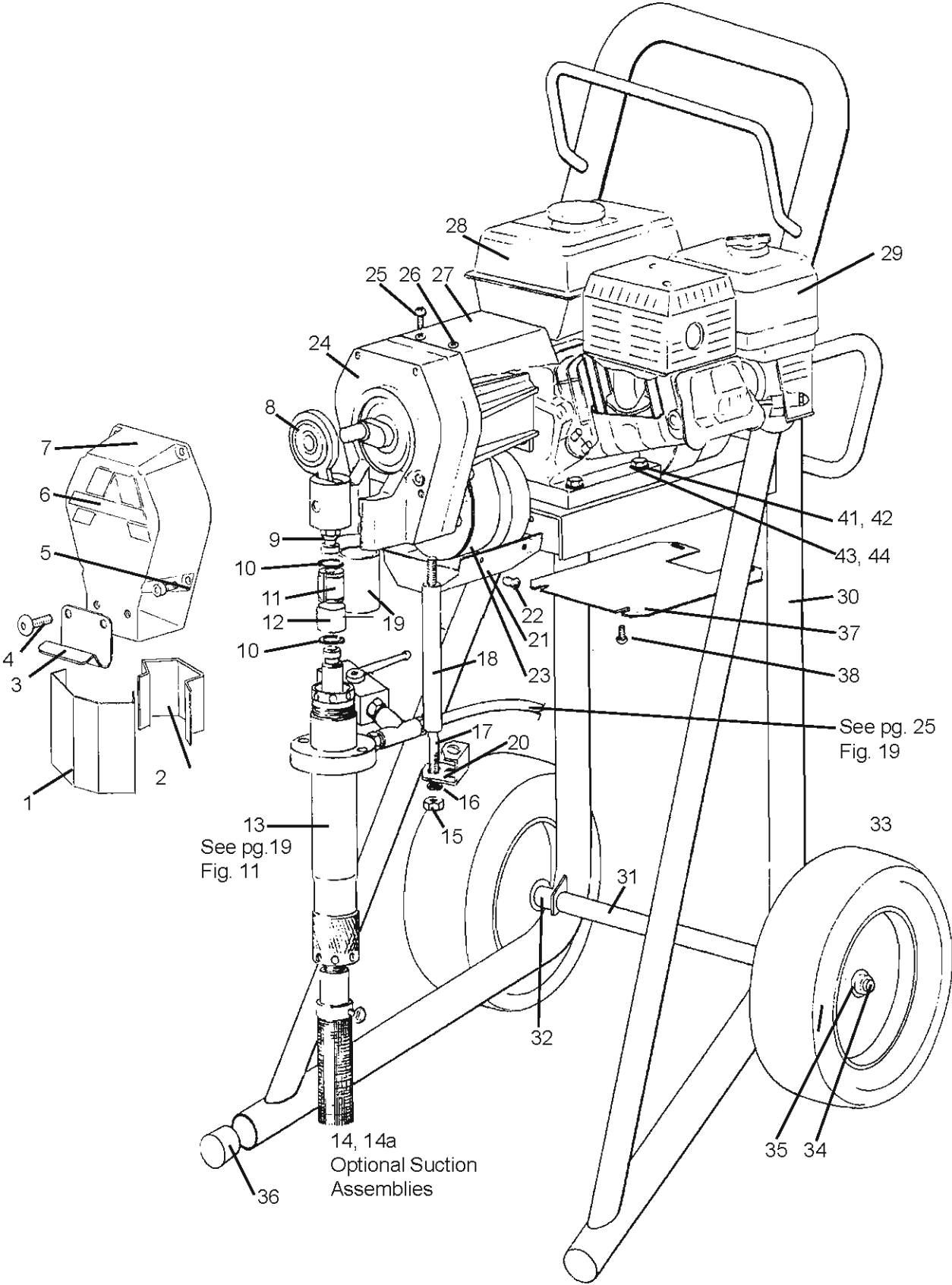

**FIG. 21 PARTS LIST, POWER UNIT ASSEMBLY, PN 305-010**

| Item No. | Part No. | Description         | Item No. | Part No. | Description           |
|----------|----------|---------------------|----------|----------|-----------------------|
| 1        | 301-047  | Sleeve Bearing      | 17       | 301-529  | Cover                 |
| 2        | 301-189  | Shield Front        | 18       | 305-064  | Holder-Manifold       |
| 3        | 189-046A | Coupling Set Ass'y  | 19       | 305-045  | Plate - Gearbox Mount |
| 4        | 301-092  | Shield - Rear       | 20       | 331-294  | Sensor Ass'y          |
| 5        | 301-048  | Spacer - Tube (2)   | 21       | 301-282  | Pressure Control      |
| 6        | 140-035  | Washer, Lock (2)    | 22       | 301-523A | Knob Ass'y            |
| 7        | 140-051  | Nut (2)             | 23       | 140-044  | Nut (8)               |
| 8        | 100-328  | Stud (2)            | 24       | 305-047  | Screw (4)             |
| 9        | 305-013  | Holder              | 25       | 301-270  | Gearbox               |
| 10       | 301-231  | Cog Belt            | 26       | 301-291  | Connecting Rod Ass'y  |
| 11       | 305-067  | Cover-Bottom        | 27       | 305-066  | Cover Top             |
| 12       | 305-012  | Adaptor             | 28       | 301-135  | Grommet (6)           |
| 13       | 100-339  | Screw (4)           | 29       | 100-312  | Screw (4)             |
| 14       | 301-524  | 5.5 HP Engine Ass'y | 30       | 301-022  | Cover -Gearbox        |
| 15       | 305-046  | Spacer Tube (4)     | 31       | 301-337  | Screw (2)             |
| 16       | 301-284  | Clutch Ass'y        |          |          |                       |

# COMPLETE SPRAYER

**FIG. 22**



# FIGURE 22 PARTS LIST - HI-BOY

| ITEM NO. | PART NO. | DESCRIPTION                  | ITEM NO. | PART NO. | DESCRIPTION                |
|----------|----------|------------------------------|----------|----------|----------------------------|
| 1        | 301-092  | Shield - rear                | 23       | 301-231  | Cog Belt                   |
| 2        | 301-189  | Shield - front               | 24       | 301-270  | Gear Box Gas               |
| 3        | 301-105  | Hook                         | 25       | 100-339  | Screw (2)                  |
| 4        | 100-360  | Screw (2)                    | 26       | 301-135  | Grommet (6)                |
| 5        | 100-312  | Screw (4)                    | 27       | 301-254  | Clutch cover, Top          |
| 6        | 301-022  | Cover -gearbox               | 28       | 301-160  | Honda Eng. QXS160(5.5hp)   |
| 7        | 101-040  | Label                        | 29       | 175-021  | Air Filter , Engine        |
| 8        | 301-291  | Connecting Rod Ass'y         | 30       | 301-239  | Frame Weldment, Gas        |
| 9        | 301-046  | Rod End                      | 31       | 301-149  | Spacer                     |
| 10       | 189-048  | Retaining Ring (2)           | 32       | 163-016  | Spacer (2)                 |
| 11       | 189-046  | Coupling Set                 | 33       | 301-165  | Wheel (2)                  |
| 12       | 189-047  | Coupling Cover               | 34       | 301-170  | Axle                       |
| 13       | 187-310  | Fluid Pump                   | 35       | 143-029  | Set Collar (2)             |
| 14       | 301-090  | Suction Ass'y, 16" (5 gal.)  | 36       | 301-134  | Solid Neoprene Stopper (2) |
| 14a      | 301-126  | Suction Ass'y, 36" (55 gal.) | 37       | 301-326  | Bottom Cover               |
| 15       | 140-051  | Nut (2)                      | 38       | 100-390  | Screw (4)                  |
| 16       | 140-035  | Washer, Lock (2)             | 41       | 140-029  | Washer 5/16 (8)            |
| 17       | 100-328  | Stud (2)                     | 42       | 136-123  | Screw, 5/16 (4)            |
| 18       | 301-048  | Spacer, Tube (2)             | 43       | 113-023  | Washer , Lock (4)          |
| 19       | 301-047  | Sleeve Bearing               | 44       | 113-022  | Nut, 5/16 (4)              |
| 20       | 301-173  | Retainer                     | 45       | 100-028  | Plug, 1/4                  |
| 21       | 301-280  | Clutch Cover - bottom        |          | 188-160  | Ground Wire Ass'y          |
| 22       | 111-037  | Screw (4)                    |          |          |                            |

FOR SAFETY, KEEP ALL LABELS ON UNIT CLEAN AND READABLE, ORDERING NEW LABELS AS REQUIRED.

## REPLACEMENT PARTS FOR FILTER (Hi-Boy)

FIG. 21

INLET 3/8" NPT (F)  
OUTLET 3/8" NPT (F)

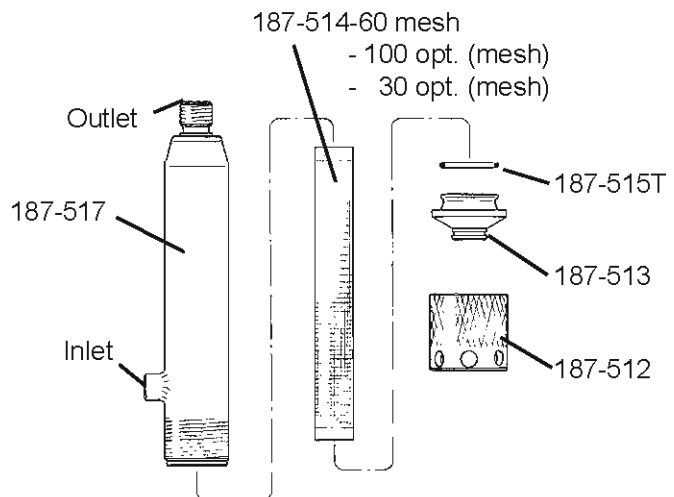

# SUCTION ASSEMBLY- LO-BOY

| FIG. 24 PARTS LIST<br>SUCTION ASS'Y (PN 301-517) |          |                |
|--|----------|----------------|
| ITEM NO.   | PART NO. | DESCRIPTION    |
| 1  | 100-165  | Elbow          |
| 2  | 250-116  | Punch Clamp    |
| 3  | 301-513  | Hose           |
| 4  | 301-514  | Suction Tube   |
| 5  | 141-008  | Inlet Strainer |

FIG. 24

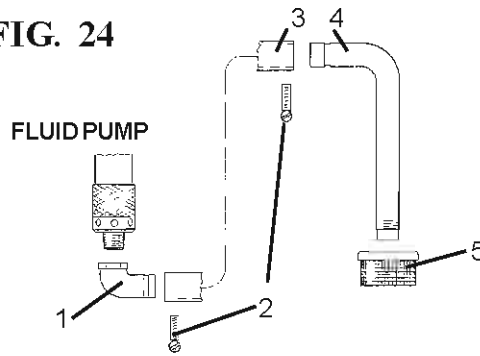

# FRAME ASSEMBLY - LO-BOY

FIG. 25

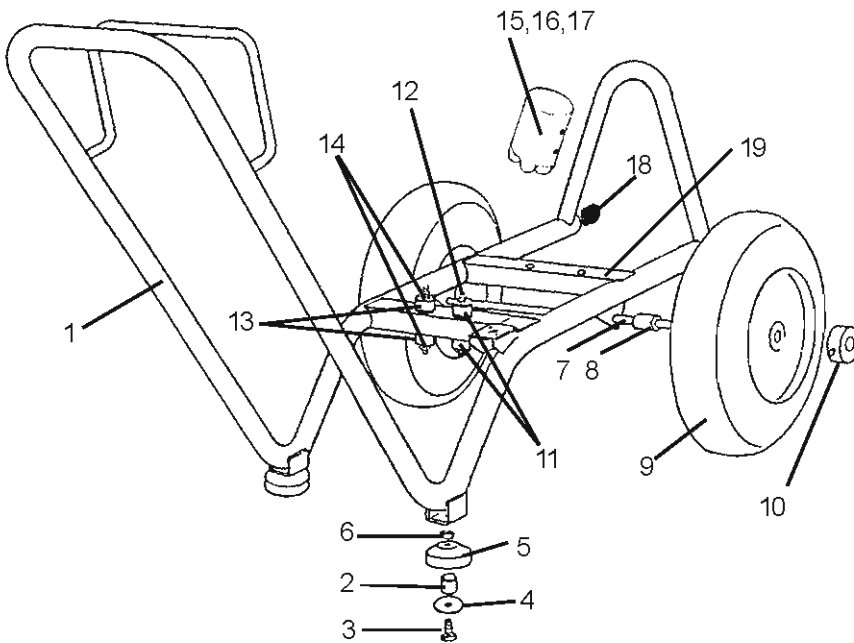

FIG. 25 PARTS LIST, PN 301-515

| ITEM NO. | PART NO. | DESCRIPTION            |
|----------|----------|------------------------|
| 1        | 301-510  | Frame Weldment, Lowboy |
| 2        | 188-185  | Spacer (2)             |
| 3        | 169-050  | Screw (2)              |
| 4        | 163-011A | Washer (2)             |
| 5        | 163-008A | Rubber Foot (2)        |
| 6        | 100-317  | Centerlock Nut (2)     |
| 7        | 188-367  | Axle                   |
| 8        | 143-011  | Spacer (2)             |
| 9        | 301-165  | Wheel (2)              |
| 10       | 143-029  | Set Collar (2)         |
| 11       | 301-536  | Shock Mount Bushing(4) |
| 12       | 301-547  | Stud (2)               |
| 13       | 100-344  | Washer (4)             |
| 14       | 100-317  | Nut (4)                |
| 15       | 100-170  | Holder                 |
| 16       | 301-546  | Screw (2)              |
| 17       | 100-020  | Lock Nut (2)           |
| 18       | 301-134  | Rubber Stopper (2)     |
| 19       | 301-535  | Rubber Pad             |

# MANIFOLD FILTER - PN 111-200-99 (Lo-Boy)

FIG. 26

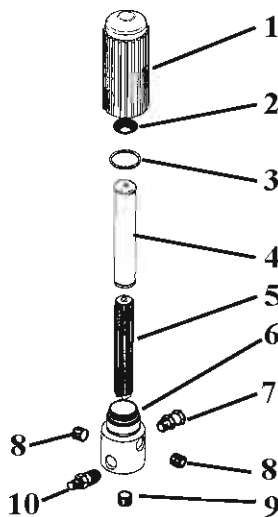

FIGURE 26 PARTS LIST

| ITEM | PART NO. | DESCRIPTION      |
|------|----------|------------------|
| 1    | 111-202  | Base*            |
| 2    | 301-356  | Spring*          |
| 3    | 106-007  | O-Ring*          |
| 4    | 111-204  | Filter           |
| 5    | 111-203  | Support*         |
| 6    | 111-201  | Base*            |
| 7    | 100-101  | Swivel           |
| 8    | 100-129  | Plug 3/8" (2)    |
| 9    | 100-028  | Plug 1/4"        |
| 10   | 100-109  | Nipple 3/8 x 1/4 |
| *    | 111-200  | Filter           |