

Instructions



Pulse[®] TLM (Tank Level Monitor)

3A5411M
EN

Measures the distance between the device and the surface of the fluid beneath it to determine the volume of fluid within a tank. Use with a Pulse operating system only. Intended fluids: oil, waste oil, automatic transmission fluid (ATF), anti-freeze, windshield washer solution, and waste water. For professional use only. Not suitable for tank overflow protection.

Not approved for use in European explosive atmosphere locations.

Part No.: 25M449



Important Safety Instructions

Read all warnings and instructions in this manual.
Save these instructions.

NOTICE

- **Do not over tighten TLM into tank bung!** Over tightening can cause permanent damage and result in inaccurate readings.
- **Do not use thread sealant or adhesive!** Many of these products are chemically incompatible with the ABS plastic. PTFE tape is acceptable.

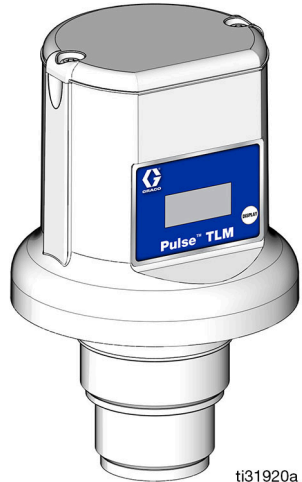

ti31920a

Contains IC: 1846A-XBEE3 or 1846A-XBS2C.

Contains FCC ID MCQ-XBEE3 or MCQ-XBS2C. The enclosed device complies with Part 15 of the FCC Rules.

Operation is subject to the following two conditions:

- This device may not cause harmful interference.
- This device must accept any interference received, including interference that may cause undesired operation.



PROVEN QUALITY. LEADING TECHNOLOGY.

Contents

Warnings	3
Set Up	5
Register the TLM	5
Configure the TLM	6
TLM Registration Process	6
TLM Display	6
Installation	7
Installation Examples	8
Operation	9
View Data	9
Take Measurement	9
Take Measurement - New Profile	10
Refill the Tank	10
Daylight Savings Time (DST) Change	10
Troubleshooting	11
Service	13
Replacing Batteries	13
Parts	15
TLM Dimensions	15
Tank Specifications and TLM Offset	16
Vertical Tank:	16
Horizontal Cylindrical Tank:	17
Obround Tank:	17
Non-Standard Tanks:	18
Technical Specifications	19
Graco Extended Tank Level Monitor Warranty	20
Graco Information	20

Warnings

The following warnings are for the setup, use, grounding, maintenance, and repair of this equipment. The exclamation point symbol alerts you to a general warning and the hazard symbols refer to procedure-specific risks. When these symbols appear in the body of this manual or on warning labels, refer back to these Warnings. Product-specific hazard symbols and warnings not covered in this section may appear throughout the body of this manual where applicable.

WARNING



FIRE AND EXPLOSION HAZARD

When flammable fluids are present in the work area, such as gasoline and windshield wiper fluid, be aware that flammable fumes can ignite or explode. To help prevent fire and explosion:

- Use equipment only in well-ventilated area.
- Eliminate all ignition sources, such as cigarettes and portable electric lamps.
- Ground all equipment in the work area.
- Keep work area free of debris, including rags and spilled or open containers of solvent and gasoline.
- Do not plug or unplug power cords or turn lights on or off when flammable fumes are present.
- Use only grounded hoses.
- **Stop operation immediately** if static sparking occurs or you feel a shock. Do not use equipment until you identify and correct the problem.
- Keep a working fire extinguisher in the work area.

Warnings

WARNING



EQUIPMENT MISUSE HAZARD

Misuse can cause death or serious injury.

- Do not operate the unit when fatigued or under the influence of drugs or alcohol.
- Do not exceed the maximum working pressure or temperature rating of the lowest rated system component. See **Technical Specifications** in all equipment manuals.
- Use fluids and solvents that are compatible with equipment wetted parts. See **Technical Specifications** in all equipment manuals. Read fluid and solvent manufacturer's warnings. For complete information about your material, request Safety Data Sheets (SDSs) from distributor or retailer.
- Turn off all equipment and follow the **Pressure Relief Procedure** when equipment is not in use.
- Check equipment daily. Repair or replace worn or damaged parts immediately with genuine manufacturer's replacement parts only.
- Do not alter or modify equipment. Alterations or modifications may void agency approvals and create safety hazards.
- Make sure all equipment is rated and approved for the environment in which you are using it.
- Use equipment only for its intended purpose. Call your distributor for information.
- Route hoses and cables away from traffic areas, sharp edges, moving parts, and hot surfaces.
- Do not kink or over bend hoses or use hoses to pull equipment.
- Keep children and animals away from work area.
- Comply with all applicable safety regulations.



PERSONAL PROTECTIVE EQUIPMENT

Wear appropriate protective equipment when in the work area to help prevent serious injury, including eye injury, hearing loss, inhalation of toxic fumes, and burns. Protective equipment includes but is not limited to:

- Protective eye wear, and hearing protection.
- Respirators, protective clothing, and gloves as recommended by the fluid and solvent manufacturer.

Set Up



NOTICE

Do not over tighten TLM into tank bung!

Over tightening can cause permanent damage and result in inaccurate readings.

Do not use the TLM with pressurized tanks. Using the TLM in a pressurized tank will damage the TLM.

Do not use thread sealant or adhesive. Many of these products are chemically incompatible with the Pulse/ABS plastic. PTFE tape is acceptable.

1. Install four, AA alkaline batteries (9) in the battery holder (8). See **Replacing Batteries**, page 13, Steps 1 - 6.

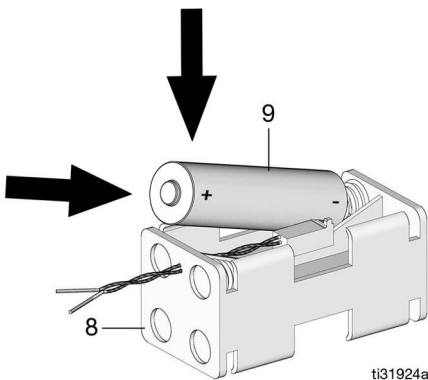

FIG. 1

Register the TLM

It is recommended that the TLM be registered prior to installation.

The TLM operating parameters are controlled by the Pulse software and set up by the System Administrator.

NOTE: Manual TLM readings taken prior to TLM configuration will be incorrect.

To register the TLM:

1. On the Pulse web portal, set the Hub, or the remote extender that the TLM communicates with, to DISCOVERY mode.
2. Press and hold the Display button (A) until the display (B) reads REGISTER, then release (FIG. 2). This may take up to 20 seconds.

NOTE: A TLM will only display REGISTER if a Hub, or remote extender, is within range and in DISCOVERY mode.

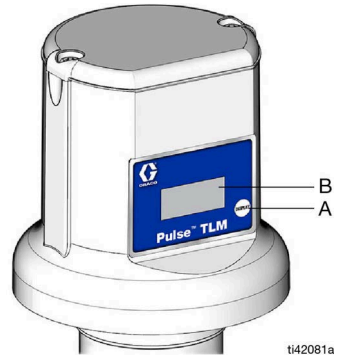

FIG. 2

3. The display reads REGISTER OK (FIG. 3, page 6) when the TLM is registered with the Pulse software. This may take up to 20 seconds.

If the TLM did not register with the Pulse software, the error message REGISTER E7 displays (see Step 1, FIG. 3).

Configure the TLM

1. Press the Display button (A) again to configure the TLM with a new profile.
2. The display reads CONFIG OK, as shown in FIG. 4, page 6, after the TLM is configured with the new profile.

If the TLM was not configured with a new profile by the Pulse software, the error message CONFIG E8 displays (Step 2, FIG. 4).

TLM Registration Process

Step 1: Connect Device

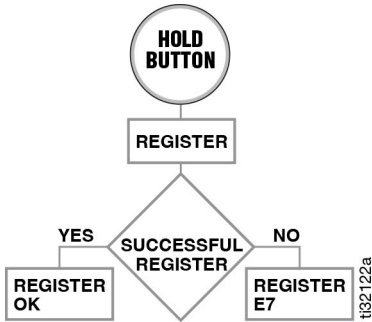

FIG. 3

Step 2: Load Initial Profile

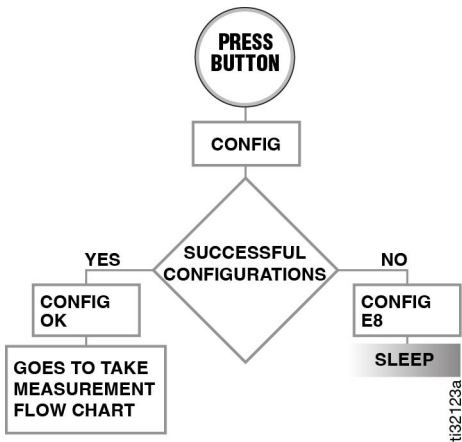

FIG. 4

TLM Display

Registration

Displays REGISTER. Successful registration adds a second line: OK. Registration failure adds a second line: ERROR.

Profile

Displays CONFIG. Successful TLM configuration adds a second line OK. Unsuccessful TLM configuration adds a second line ERROR.

Measurement Reporting

Displays REPORT. If data is successfully transmitted, adds a second line OK. If data is not successfully transmitted, adds a second line ERROR.

Sensor Communication Error

If the sensor does not respond to commands before timeout, a communication error is flagged. Displays COMM ERR.

Bad Measurement

If there is a communication error during a read measurement (i.e., timeout), or the status from the read measurement command indicates there is an issue, SENSOR ERR # is displayed. The # corresponds to the following Sensor Error Table.

SENSOR ERROR TABLE

Error	Description
Sensor E0	Invalid reading or sensor communication error
Sensor E1	No sensor PCBA detected (damaged circuit board)
Sensor E4	Invalid profile parameter
Sensor E5	Measurement exceeds maximum length
Sensor E7	Registration error
Sensor E8	Profile error
Sensor E9	RF communication error (no acknowledge or no signal)

Installation

NOTICE

Do not over tighten TLM into tank bung!

Over tightening can cause permanent damage and result in inaccurate readings.

Do not use thread sealant or adhesive!

Many of these products are chemically incompatible with the ABS plastic. PTFE tape is acceptable.

Do not locate TLM next to the tank wall.

The wall can interfere with the sensor's 30 degree cone angle.

Do not install the TLM in the tank's fill port. Repeated removal of the TLM will damage the unit and void the warranty.

1. Remove the bung fitting and screw in the TLM hand-tight.
 - Do not use a wrench to tighten as this may damage the TLM.
 - Do not use thread lock adhesive as this may damage the TLM.
2. Mount the TLM as close as possible to the center of the tank.
3. Do not mount any fittings or T connects between TLM and the tank.

NOTICE

The TLM will not operate correctly if tilted more than 2° from the surface of the tank liquid.

The TLM will not operate correctly if the TLM is mounted less than 5 in. (127 mm) from the maximum possible fill height of the fluid being measured.

The TLM will not read properly if:

- Fluid in the tank is agitated (e.g. filling a tank with oil or anti-freeze). Be sure to take all TLM readings when the fluid in the tank is calm.
- The TLM is mounted next to the tank wall or in a corner.
- If there is any structural bracing or obstruction between the TLM and the surface of fluid in tank.

TLM must be mounted within 2° from perpendicular to the surface of the fluid.

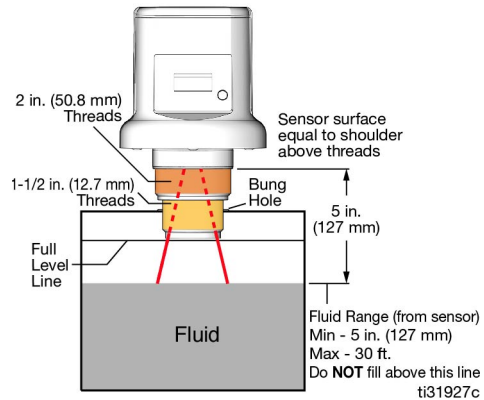
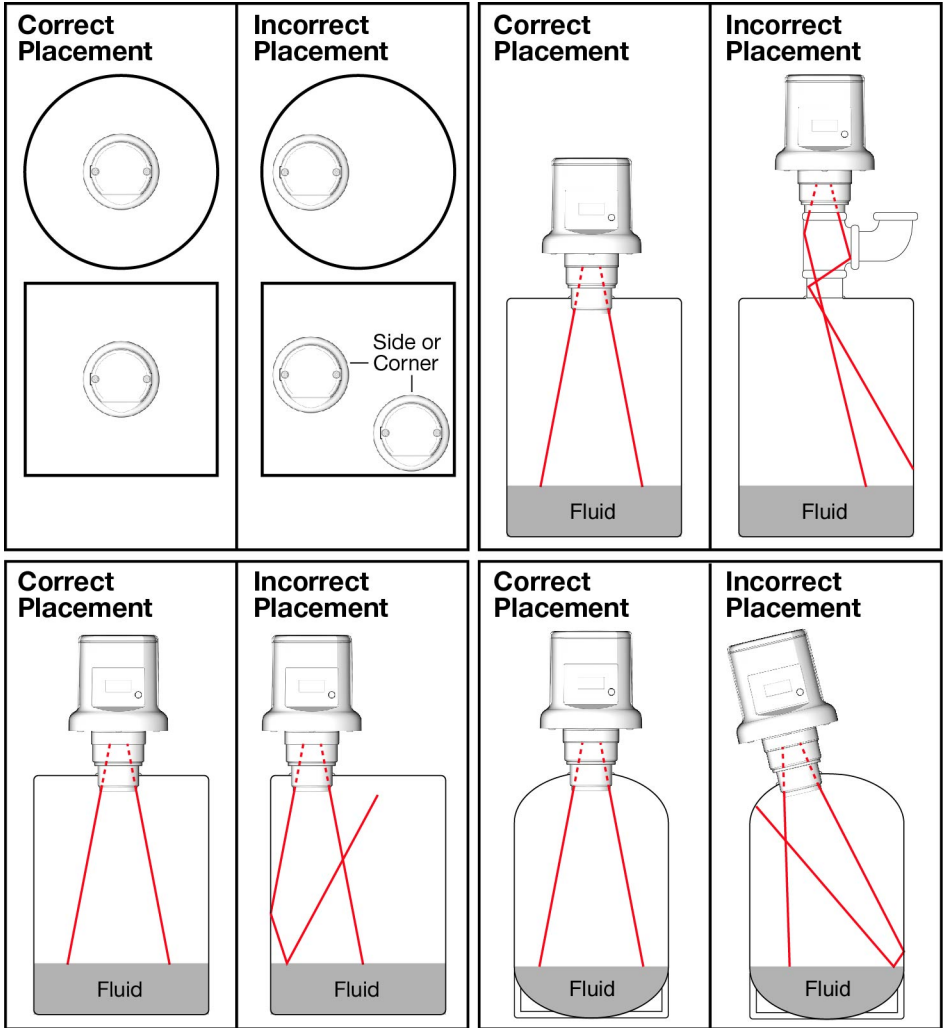

FIG. 5

Installation Examples



ti42082a

FIG. 6

Operation

View Data

The TLM can be configured with the Pulse software to take a reading at predefined times.

Press and release the display button (A). Data appears on the display (B) (FIG. 7); each screen lasting a few seconds before going on to the next.

FIG. 8 shows the order that the screens display when taking a measurement.

FIG. 9, page 10 shows the order that the screens display when taking a measurement after a new profile is entered using the Pulse software.

NOTE: The tank level data can also be viewed remotely using the Pulse software.

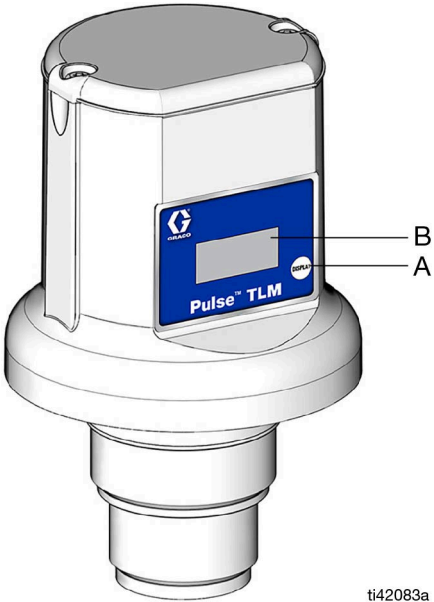

ti42083a

FIG. 7

Take Measurement

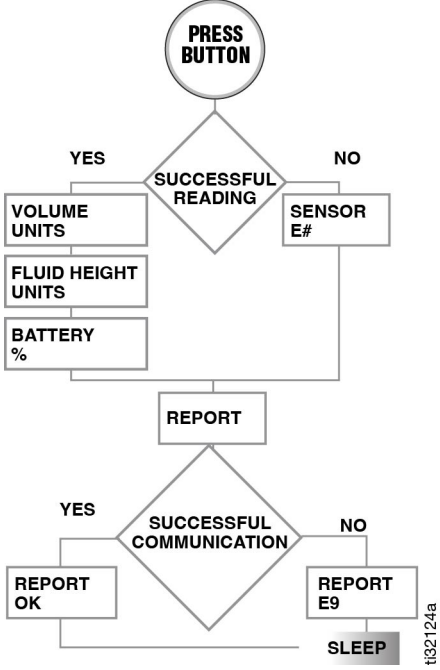

FIG. 8

Take Measurement - New Profile

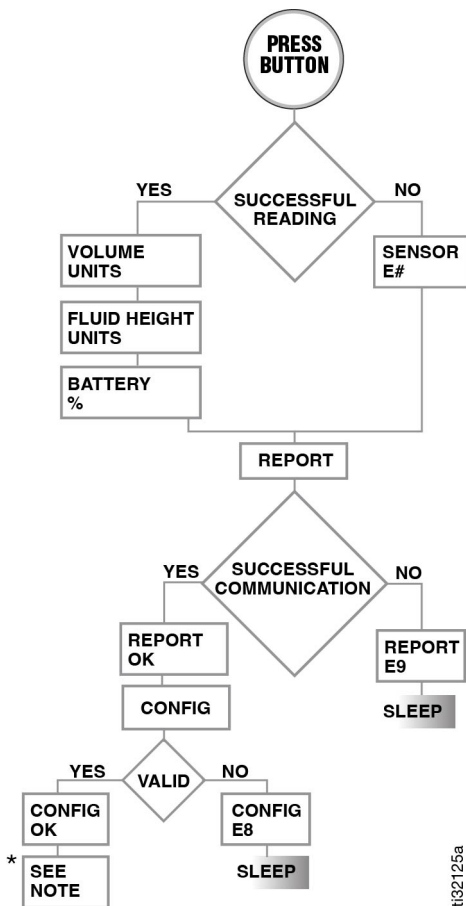

FIG. 9: *NOTE: TLM will take a measurement after a new profile has been loaded

Refill the Tank

After a tank is refilled from an oil distributor or a waste oil tank is emptied by a waste oil service provider, press the display button (A) (FIG. 7) on the TLM to ensure that the TLM will maintain the most current tank volume status.

If the display button is not pushed, the TLM will automatically read correctly at the next scheduled tank reading.

Daylight Savings Time (DST) Change

The Pulse software automatically adjusts the time when daylight savings time changes occur (Spring and Fall).

NOTE: The first TLM reading will be one hour earlier or later (depending on the season, Spring or Fall time change). All subsequent TLM readings will be accurate.

Troubleshooting

Problem	Cause	Solution
Brand new monitor's display is very dim.	Unit is shipped with protective coating over display.	Remove protective coating.
Monitor displays "Invalid Reading".	The TLM reading is outside of the programmed size parameters.	Verify the programmed parameters and re-program the TLM if necessary.
Monitor will not register.	Weak or dead batteries.	Replace batteries. See Replacing Batteries , page 13.
	Microprocessor not completely shut down before installing new batteries.	After you have removed old batteries, wait 30 seconds to ensure the microprocessor has completely shut down, before installing new batteries.
Monitor is not reporting scheduled readings	Out of RF range. RF obstruction.	Add Graco Extender to Pulse System. Order Graco Part No. 17F885 - US/Canada; 17F886 - EU; 17F887 - UK; 17F888 - ANZ.
	Weak or dead batteries.	Replace batteries. See Replacing Batteries , page 13.
	Microprocessor not completely shut down before installing new batteries.	After removing the old batteries, wait 30 seconds to ensure the microprocessor has completely shut down, before installing new batteries.
	Tank Level Monitor was not associated with profile after scheduled times were entered into software.	Reregister Tank Level Monitor and associate Tank Level Monitor with profile ID.
	Reading is scheduled when pump is operating.	Ensure readings are scheduled at times that the pump is not operating.
Monitor will not take reading when Display button is pressed.	Weak or dead batteries.	Replace batteries. See Replacing Batteries , page 13.
	Batteries are not correctly seated.	Ensure the batteries fully engage the mounting clips by pushing on the bottom of each battery with your thumbs.
	Microprocessor not completely shut down before installing new batteries.	After you have removed old batteries, wait 30 seconds to ensure the microprocessor has completely shut down, before installing new batteries.
	Monitor display is cracked.	Replace TLM.

Troubleshooting



Problem	Cause	Solution
Weak or no RF signal	Changes/obstructions in RF pathway (i.e., vehicles, overhead doors, etc.)	Add Graco Extender to Pulse System. Order Graco Part No. 17F885 - US/Canada; 17F886 - EU; 17F887 - UK; 17F888 - ANZ.
	Weak or dead batteries	Replace batteries. See Replacing Batteries , page 13.
Monitor readings are inaccurate.	Tank geometry incorrectly defined.	See <i>Tank Level Monitor Software Guide</i> or <i>PC Software Guide</i> for details.
	Tank Level Monitor has not been updated with latest adjustments made within The profile ID on the Pulse system.	Manually push DISPLAY button on TLM.
	Fluid surface is moving while reading is being taken.	Ensure pump is not operating and that nothing is disturbing the surface of the fluid during readings.
	Pipe adapters installed in the tank bung.	Ensure there are no adapters installed in the tank bung.
	Tank Level Monitor is not perpendicular to top of fluid.	Level tank so that it is perpendicular to top of the fluid and/or realign Tank Level Monitor.
	Inside tank obstruction.	Install in different tank bung to avoid tank obstruction.
Device is unable to register to the Pulse Pro network or the device does not rejoin the network after system reboot.	Device is not meshing properly with the device network.	Toggle to Discovery mode on the HUB. Wait one minute and toggle it back. Press the button to attempt a network connection. If this does not resolve the issue, remove the batteries, wait two minutes then reinstall the batteries.

Service

After the TLM has been installed, the only additional maintenance or service necessary is changing the batteries.

Replacing Batteries

Always replace **all four** batteries with four, new, AA, alkaline batteries whenever you change the TLM batteries.

				
<p>Sparking can occur when changing batteries. Only replace the batteries in a non-hazardous location away from flammable fluids and fumes.</p>				

NOTICE

After battery replacement, press the display button to synchronize the TLM internal clock to maintain scheduled TLM readings.

1. Remove two screws (11) and cover (3) (FIG. 10).

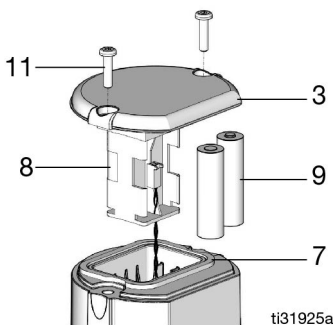

FIG. 10

2. Carefully pull battery holder (8) out of TLM just far enough to install the batteries (FIG. 10).

NOTICE

Do not attempt to separate the battery holder from the TLM. The power and ground wires are secured to the bottom of the battery holder. Attempting to totally remove the battery holder from the TLM will break this connection and disconnect power to the TLM.

3. Remove all four AA batteries from the battery holder (8). Discard batteries in an approved battery disposal container.
4. Install four, AA, alkaline batteries (9) in the battery holder (8) as shown in FIG. 11. Make sure batteries lie flat in holder.

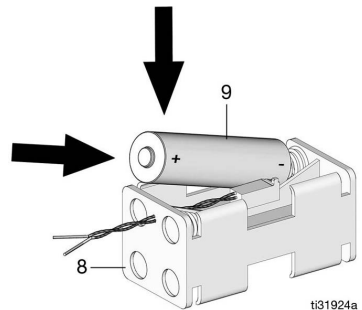

FIG. 11

5. Remove seal (7) from housing (1), if necessary. Make sure that the seal is installed onto cover (3). Apply a thin film of oil or grease to the seal to lubricate for installation (FIG. 12).

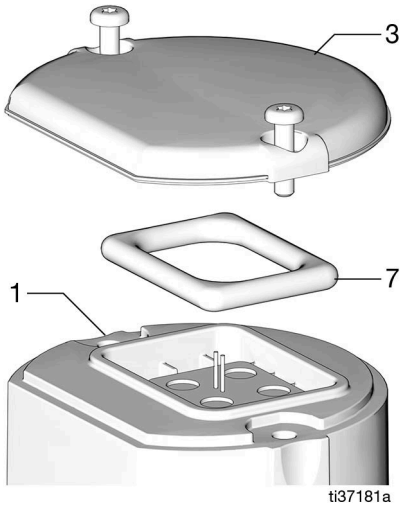

FIG. 12

6. Replace cover (3) and secure it with the two cover screws (11). Torque cover screws to 18 to 22 in.-lbs (2.03 to 2.48 N•m) to prevent water leakage into the TLM electronics.

NOTE: If a torque wrench is not used, verify there are no gaps under the screw heads and no gaps under the cover flange. This will ensure proper compression of the gasket for a water-tight seal.

7. Press the Display button to synchronize the TLM's internal clock with the Pulse software clock. If this is not done, the TLM will not report at the correct scheduled times.

Parts

Ref	Part No.	Description	Qty
1		HOUSING	1
3	★	COVER	1
7	★	SEAL, cover	1
8		HOLDER, battery	1
9		BATTERY, alkaline AA	4
11	131260	SCREW, mach, pnh, torx	2

★ Kit 25P682 includes 3, 7

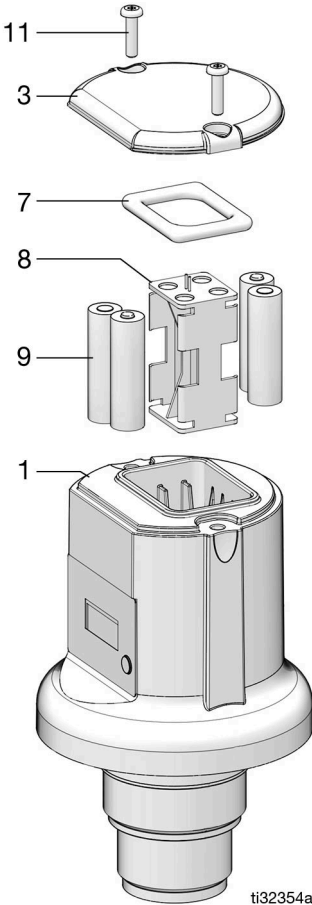

TLM Dimensions

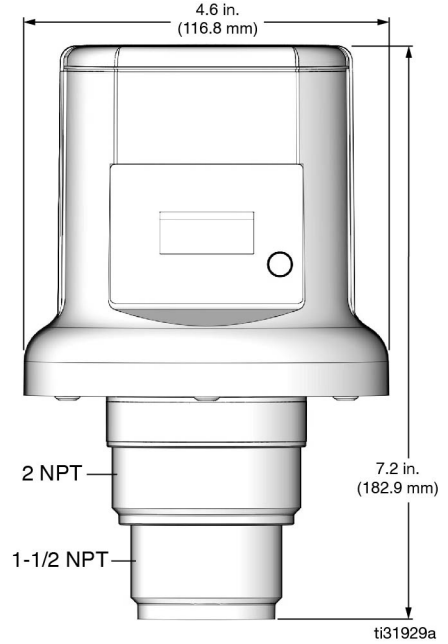

FIG. 13

Tank Specifications and TLM Offset

Vertical Tank:

- Maximum Volume = 999,999 gallons or liters.
- Tank walls must be uniformly vertical from empty level to full (FIG. 14 and FIG. 15).

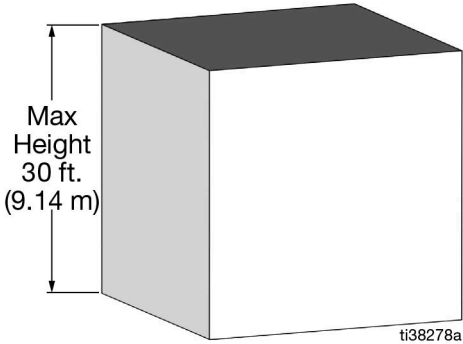

FIG. 14

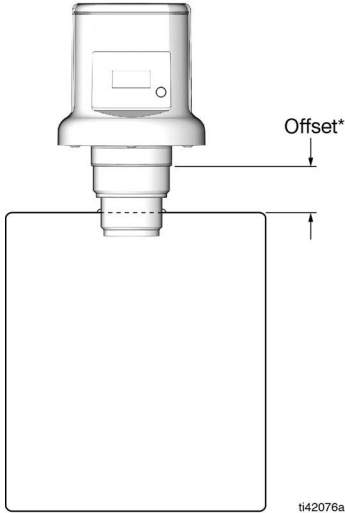

FIG. 16: NOTE: *TLM Offset is the distance from the maximum height to the shoulder above the threads on TLM.

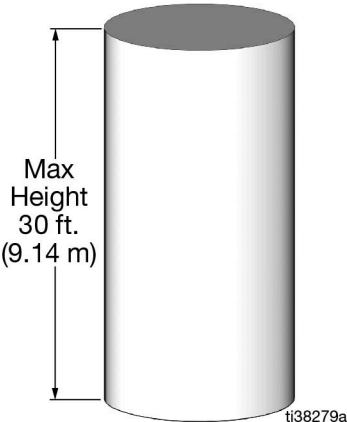

FIG. 15

Tank Specifications and TLM Offset

Horizontal Cylindrical Tank:

- Maximum Volume = 999,999 gallons or liters.
- Tank end walls must be flat; they cannot be any other shape, including belled (FIG. 17). If needed, use a non-standard tank.

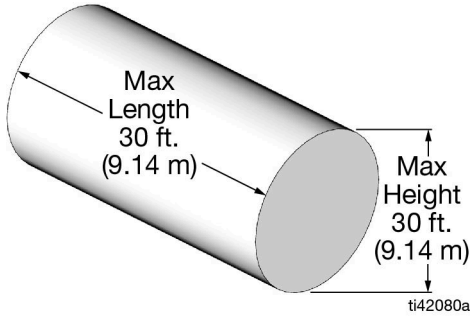

FIG. 17

Ovoid Tank:

- Maximum Volume = 999,999 gallons or liters.
- Tank end walls must be flat; they cannot be any other shape including belled (FIG. 19). If applicable, use non-standard tank.

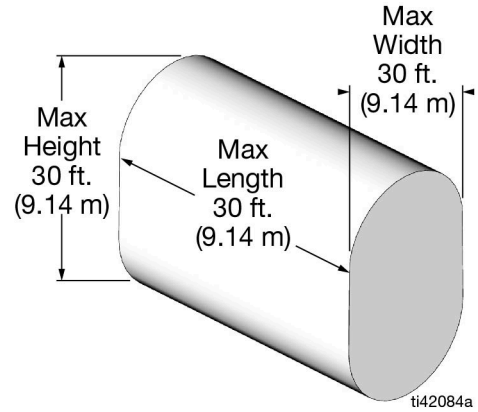

FIG. 19

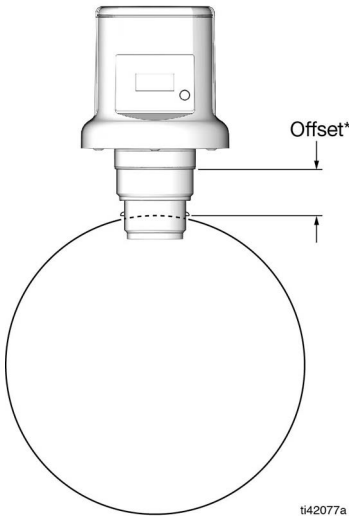

FIG. 18: NOTE: *TLM Offset is the distance from the maximum height to the shoulder above the threads on TLM.

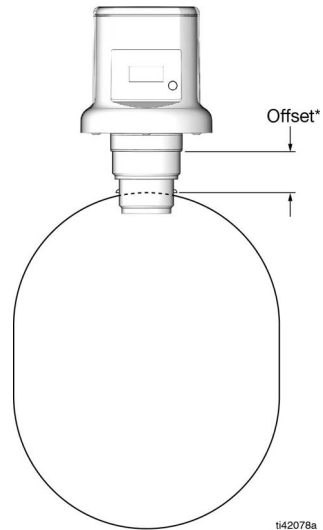
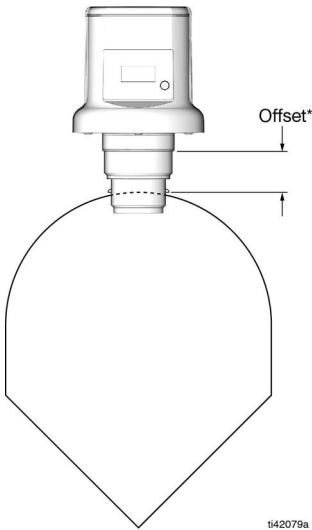

FIG. 20: NOTE: *TLM Offset is the distance from the maximum height to the shoulder above the threads on TLM.

Tank Specifications and TLM Offset

Non-Standard Tanks:

- Maximum Volume = 999,999 gallons or liters.
- The volume at various distances from the TLM can be entered into the Pulse software.
- A maximum of 30 points can be inputted into the Pulse software.
- Maximum height of 30 ft. (9.14 m).



ti42079a

FIG. 21: NOTE: *TLM Offset is the distance from the maximum height to the shoulder above the threads on TLM.

Technical Specifications

Tank Level Monitor (TLM)		
	US	Metric
Compatible Fluids	oil, waste oil, automatic transmission fluid (ATF), anti-freeze, windshield washer solution, and waste water	
Ultrasonic Tank Depth Measurement range	5 in. to 30 ft.	12.7 cm to 9.14 m
Fluid Level Measurement Accuracy	+/- 1.8 in.	+/- 4.57 cm
Mounting	1.5 in. and 2 in. threaded NPT connector	
Clearance: Height above tank for TLM	7.5 inches	19.1 cm
Weight (with batteries installed)	1.25 lb.	567 g
RF Frequency Band	2400-2483.5 MHz	
Maximum RF Transmit Power	6.3 mW (8 dBm)	
Operating Temperature Range (Display will not function below 32°F (0°C))	-22° F to 185° F	- 30° C to 85° C
Storage Temperature Range	-40°F to 185°F	-40°C to 85°C
Batteries	Four AA alkaline	
Battery Life	5 years	
Enclosure (Ingress Protection)	IP65	IP65
Tanks		
Vertical Tanks		
Maximum Volume	999,999 gallons	999,999 liters
Maximum Height	30 ft.	9.14 m
Cylindrical Tanks		
Maximum Volume	999,999 gallons	999,999 liters
Maximum Height	30 ft.	9.14 m
Maximum Length	30 ft.	9.14 m
Obround Tanks		
Maximum Volume	999,999 gallons	999,999 liters
Maximum Height	30 ft.	9.14 m
Maximum Length	30 ft.	9.14 m
Maximum Width	30 ft.	9.14 m
Strapping Table		
Maximum Volume	999,999 gallons	999,999 liters

California Proposition 65

CALIFORNIA RESIDENTS

 **WARNING:** Cancer and reproductive harm – www.P65warnings.ca.gov.

Graco Extended Tank Level Monitor Warranty

Graco warrants all equipment manufactured by Graco and bearing its name to be free from defects in material and workmanship on the date of sale to the original purchaser for use. With the exception of any special, extended, or limited warranty published by Graco, Graco will, for a period of twenty four months from the date of sale, repair or replace any part of the equipment determined by Graco to be defective. This warranty applies only when the equipment is installed, operated and maintained in accordance with Graco's written recommendations.

This warranty does not cover, and Graco shall not be liable for general wear and tear, or any malfunction, damage or wear caused by faulty installation, misapplication, abrasion, corrosion, inadequate or improper maintenance, negligence, accident, tampering, or substitution of non-Graco component parts. Nor shall Graco be liable for malfunction, damage or wear caused by the incompatibility of Graco equipment with structures, accessories, equipment or materials not supplied by Graco, or the improper design, manufacture, installation, operation or maintenance of structures, accessories, equipment or materials not supplied by Graco.

This warranty is conditioned upon the prepaid return of the equipment claimed to be defective to an authorized Graco distributor for verification of the claimed defect. If the claimed defect is verified, Graco will repair or replace free of charge any defective parts. The equipment will be returned to the original purchaser transportation prepaid. If inspection of the equipment does not disclose any defect in material or workmanship, repairs will be made at a reasonable charge, which charges may include the costs of parts, labor, and transportation.

THIS WARRANTY IS EXCLUSIVE, AND IS IN LIEU OF ANY OTHER WARRANTIES, EXPRESS OR IMPLIED, INCLUDING BUT NOT LIMITED TO WARRANTY OF MERCHANTABILITY OR WARRANTY OF FITNESS FOR A PARTICULAR PURPOSE.

Graco's sole obligation and buyer's sole remedy for any breach of warranty shall be as set forth above. The buyer agrees that no other remedy (including, but not limited to, incidental or consequential damages for lost profits, lost sales, injury to person or property, or any other incidental or consequential loss) shall be available. Any action for breach of warranty must be brought within two (2) years of the date of sale Graco makes no warranty, and disclaims all implied warranties of merchantability and fitness for a particular purpose in connection with accessories, equipment, materials or components sold but not manufactured by Graco. These items sold, but not manufactured by Graco (such as electric motors, switches, hose, etc.), are subject to the warranty, if any, of their manufacturer. Graco will provide purchaser with reasonable assistance in making any claim for breach of these warranties.

In no event will Graco be liable for indirect, incidental, special or consequential damages resulting from Graco supplying equipment hereunder, or the furnishing, performance, or use of any products or other goods sold hereto, whether due to a breach of contract, breach of warranty, the negligence of Graco, or otherwise.

FOR GRACO CANADA CUSTOMERS

The parties acknowledge that they have required that the present document, as well as all documents, notices and legal proceedings entered into, given or instituted pursuant hereto or relating directly or indirectly hereto, be drawn up in English. Les parties reconnaissent avoir convenu que la rédaction du présente document sera en Anglais, ainsi que tous documents, avis et procédures judiciaires exécutés, donnés ou intentés à la suite de ou en rapport, directement ou indirectement, avec les procédures concernées.

Graco Information

For the latest information about Graco products, visit www.graco.com.

For patent information, see www.graco.com/patents.

TO PLACE AN ORDER, contact your Graco distributor or call to identify the nearest distributor.
Phone: 612-623-6928 or **Toll Free:** 1-800-533-9655, **Fax:** 612-378-3590

All written and visual data contained in this document reflects the latest product information available at the time of publication.

Graco reserves the right to make changes at any time without notice.

Original instructions. This manual contains English. MM 3A5411

Graco Headquarters: Minneapolis
International Offices: Belgium, China, Japan, Korea

GRACO INC. AND SUBSIDIARIES • P.O. BOX 1441 • MINNEAPOLIS MN 55440-1441 • USA

Copyright 2017, Graco Inc. All Graco manufacturing locations are registered to ISO 9001.

www.graco.com

Revision M, December 2022