



InvisiPac[®] HM25c Hot Melt Delivery System

3A4938M
EN

***For delivering and dispensing hot melt adhesive pellets. For professional use only.
Not approved for use in explosive atmospheres or hazardous locations.***

See page 4 for **Models** information.

*1200 psi (8.3 MPa, 83 bar) Maximum Fluid Working Pressure
400°F (204°C) Maximum Fluid Operating Temperature
100 psi (0.7 MPa, 7 bar) Maximum Air Inlet Pressure*



Important Safety Instructions

Read all warnings and instructions in this manual and in the applicator and hose manuals. Save all instructions.

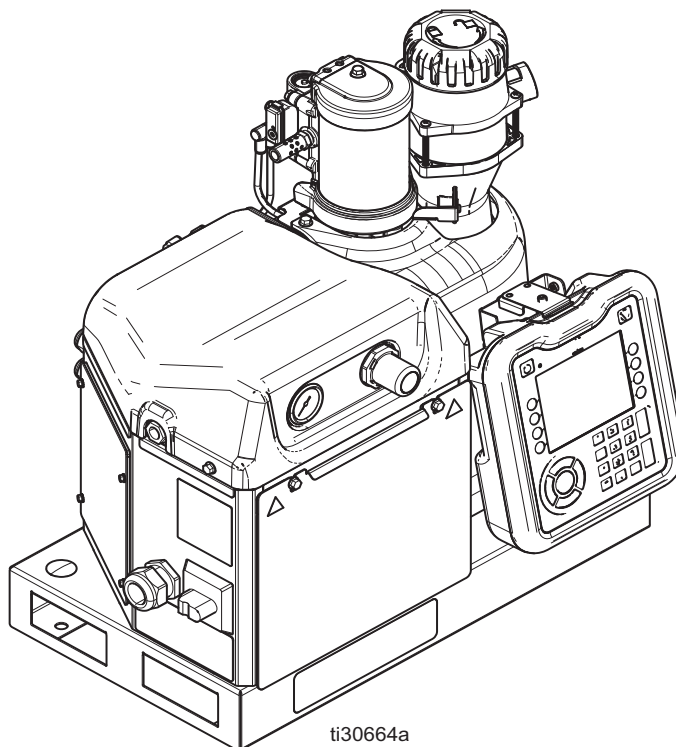

PROVEN QUALITY. LEADING TECHNOLOGY.

Intertek
9902471
Certified to
CAN/CSA C22.2 No. 88
Conforms to
ANSI/UL 499

Contents

Related Manuals	3	Repair	39
Required Tools	3	System	39
Models	4	Air Controls	40
Warnings	5	Melter	41
Component Identification (typical installation) ...	8	Pump	45
Setup	9	Replace the Pump Inlet Housing Check and Cylinder Seals	49
Grounding	9	Heaters	51
Location	9	Replace Electrical Component(s)	52
Connect Feed System	10	Electrical Schematics	54
Connect Heated Hoses	11	Common Schematic (all systems)	54
Connect Applicators	12	Incoming Power	55
Connect Air Supply	13	8 Channel Systems (25C702, 25C703, 25C722, 25C723)	56
Connect PLC Inputs	16	Pattern Controller	56
Connect PLC Outputs	18	Typical Hose/Applicator Wiring	57
Connect Material Tracking Input	19	Air Control Schematic	57
Connect Accessories	20	Parts	58
Connect Electrical Cord	20	Common System Parts	58
Select ADM Settings	21	Common System Parts (continued)	60
Operation	23	8-Channel, Pattern Controller, and 480V System Parts	62
Overview	23	Safety and Identification Labels	65
Initial Startup and Prime	23	Air Control Assembly 25C468 Parts	66
Automatic Refill	24	Melter Assembly 17S257 Parts	68
Manual Refill	24	Accessories	70
Dispense	25	Adapter Plate Kit, 25M528	70
Shutdown	25	System Stand Kit, 17S264	70
Schedule	26	Light Tower Kit, 25C662	71
Pressure Relief Procedure	26	HM25C Melter Guard Kit, 25D461	72
Operation Tips to Maximize Adhesive Life ...	26	Fluid Port Connectors Kit 24V504	72
Maintenance	27	ADM Remote Mount Extension Cables	73
Inspect Funnel and Filter	27	Material Tracking Kit	73
Replace Pump Outlet Filter	27	Hose Adapters	74
Replace Pump Inlet Filter	28	Applicator Adapters	74
Drain System	29	Upgrade Kits	75
Flush	29	Air Reservoir Kit, 16W366	79
Troubleshooting	31	Appendix A - ADM (Advanced Display Module) .	80
Error Codes	31	ADM Interface	80
Alarms (shuts system down)	32	Screen Navigation	80
Fill System Verification	37	ADM Screens	81
Input Power Verification	37	Appendix B - USB Downloading, Uploading	93
Melter Pump and Fluid Hose Leak Troubleshooting	37	Download Procedure	93
		Accessing Files	93
		Upload Procedure	93
		USB Logs	94
		System Settings File	94
		System Language File	95

Appendix C - Software Update	96	Dimensions	112
Software Update Procedure	96	240V System Dimensions	112
Appendix D - Automation Gateway Interface ...	97	System with 480V Transformer	112
Overview	97	Mounting Hole Dimensions	113
Installation	97	System with Stand and Feed Hose Dimensions	114
SETUP	99	Technical Specifications	115
Ethernet/IP Fieldbus Screens	100	California Proposition 65	116
DeviceNet FieldBus Screen	101	Startup Time	117
Available Internal Data	101	Graco Standard Warranty	118
Automation Inputs	103		
Command Interface	105		
Command Interface Timing Diagram	105		
Command Interface Table	106		
Bead Offset Lookup Table	110		
Bead Length Lookup Table	111		

Related Manuals

Manuals are available at www.graco.com.
Component manuals in English:

Part	Description
334627	InvisiPac GM100 Plug-Free Hot Melt Applicator
3A2805	InvisiPac GS35 Hot Melt Applicator
332072	InvisiPac Heated Hose
3A4937	InvisiPac Standard Feed System
334629	InvisiPac Advanced Feed System
334784	InvisiPac Pattern Controller
334610	LineSite® Remote Monitoring Solution
312864	Communications Gateway Module, Instructions - Parts
3A3948	InvisiPac HM25c Tank -Free Hot Melt delivery System, Instructions - Parts
406987	GCA CAN Cables, Reference

Required Tools

- Standard allen wrench set
- Metric allen wrench set
- Various sizes of crescent wrenches
- 11/16 in. wrench
- 3/8 in. ratchet
- 3/8 in. socket
- 5/16 in. driver
- 7/16 in. socket
- 7/8 in. deep well socket
- 1 in. socket
- 13 mm socket
- 10 mm socket
- 1/2 in. ratchet
- Side cutter
- Phillips head screwdriver
- Flat head screwdriver
- Multimeter
- Tubing cutter

Models

InvisiPac HM25c System Models

NOTE: InvisiPac HM25c system part numbers listed below do not include a feed system. Refer to the **Feed Systems** table below to select the appropriate feed system for use with selected InvisiPac HM25c system.

Part	Pattern Controller	Channels	Voltage (VAC, 50/60 Hz)	Max Amps
25C700	Not included	4	200-240 1Φ/3Φ, 350-415 3Φ + N	32 A
25C701	PC-8*			
25C702	Not included	8		
25C703	PC-8*			
25C720	Not included	4	400-480 3Φ	16 A
25C721	PC-8*			
25C722	Not included	8		
25C723	PC-8*			



* Order kit 17F712 to upgrade to PC-8e (includes Key Token for Encoder). Refer to manual 334784 - InvisiPac Pattern Controller for details.

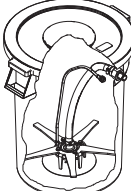
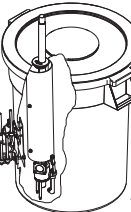
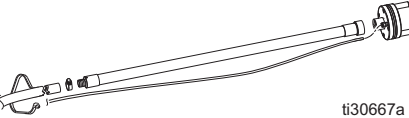





Feed Systems

Part	Usage
<p>25C193</p> 	For use in standard pellet feed applications
<p>17D749</p>  <p>ti30666a</p>	For use in chiclet feed applications
<p>24N957</p>  <p>ti30667a</p>	For use in standard pellet feed applications with separate feed bin or bulk container

Warnings

The following warnings are for the setup, use, grounding, maintenance, and repair of this equipment. The exclamation point symbol alerts you to a general warning and the hazard symbols refer to procedure-specific risks. When these symbols appear in the body of this manual or on warning labels, refer back to these Warnings. Product-specific hazard symbols and warnings not covered in this section may appear throughout the body of this manual where applicable.

 DANGER	
	<p>SEVERE ELECTRIC SHOCK HAZARD</p> <p>This equipment can be powered by more than 240V. Contact with this voltage will cause death or serious injury.</p> <ul style="list-style-type: none"> • Turn off and disconnect power at main switch before disconnecting any cables and before servicing equipment. • This equipment must be grounded. Connect only to grounded power source. • All electrical wiring must be done by a qualified electrician and comply with all local codes and regulations.

 WARNING	
	<p>BURN HAZARD</p> <p>Equipment surfaces and fluid that is heated can become very hot during operation. To avoid severe burns:</p> <ul style="list-style-type: none"> • Do not touch hot fluid or equipment.
	<p>SKIN INJECTION HAZARD</p> <p>High-pressure fluid from dispensing device, hose leaks, or ruptured components will pierce skin. This may look like just a cut, but it is a serious injury that can result in amputation. Get immediate surgical treatment.</p> <ul style="list-style-type: none"> • Do not point dispensing device at anyone or at any part of the body. • Do not put your hand over the fluid outlet. • Do not stop or deflect leaks with your hand, body, glove, or rag. • Follow the Pressure Relief Procedure, page 26 when you stop dispensing and before cleaning, checking, or servicing equipment. • Tighten all fluid connections before operating the equipment. • Check hoses and couplings daily. Replace worn or damaged parts immediately.
	
	
	



WARNING



FIRE AND EXPLOSION HAZARD

Flammable fumes, such as solvent and paint fumes, in work area can ignite or explode. To help prevent fire and explosion:

- Do not use solvent-based adhesives that can create an explosive atmosphere when processed.
- Use equipment only in well ventilated area.
- Eliminate all ignition sources; such as pilot lights, cigarettes, portable electric lamps, and plastic drop cloths (potential static sparking).
- Ground all equipment in the work area. See **Grounding** instructions.
- Never spray or flush at high pressure
- Keep work area free of debris, including solvent, rags and gasoline.
- Do not plug or unplug power cords, or turn power or light switches on or off when flammable fumes are present.
- Use only grounded hoses.
- **Stop operation immediately** if static sparking occurs or you feel a shock. Do not use equipment until you identify and correct the problem.
- Keep a working fire extinguisher in the work area.



MOVING PARTS HAZARD

Moving parts can pinch, cut or amputate fingers and other body parts.

- Keep clear of moving parts.
- Do not operate equipment with protective guards or covers removed.
- Pressurized equipment can start without warning. Before checking, moving, or servicing equipment, follow the **Pressure Relief Procedure**, page 26 and disconnect all power sources.



EQUIPMENT MISUSE HAZARD

Misuse can cause death or serious injury.

- Do not operate the unit when fatigued or under the influence of drugs or alcohol.
- Do not exceed the maximum working pressure or temperature rating of the lowest rated system component. See **Technical Specifications** in all equipment manuals.
- Use fluids and solvents that are compatible with equipment wetted parts. See **Technical Specifications** in all equipment manuals. Read fluid and solvent manufacturer's warnings. For complete information about your material, request Safety Data Sheets (SDSs) from distributor or retailer.
- Do not leave the work area while equipment is energized or under pressure.
- Turn off all equipment and follow the **Pressure Relief Procedure**, page 26 when equipment is not in use.
- Check equipment daily. Repair or replace worn or damaged parts immediately with genuine manufacturer's replacement parts only.
- Do not alter or modify equipment. Alterations or modifications may void agency approvals and create safety hazards.
- Make sure all equipment is rated and approved for the environment in which you are using it.
- Use equipment only for its intended purpose. Call your distributor for information.
- Route hoses and cables away from traffic areas, sharp edges, moving parts, and hot surfaces.
- Do not kink or over bend hoses or use hoses to pull equipment.
- Keep children and animals away from work area.
- Comply with all applicable safety regulations.

 **WARNING****TOXIC FLUID OR FUMES HAZARD**

Toxic fluids or fumes can cause serious injury or death if splashed in the eyes or on skin, inhaled, or swallowed.

- Read Safety Data Sheets (SDSs) to know the specific hazards of the fluids you are using.
- Store hazardous fluid in approved containers, and dispose of it according to applicable guidelines.

**PERSONAL PROTECTIVE EQUIPMENT**

Wear appropriate protective equipment when in the work area to help prevent serious injury, including eye injury, hearing loss, inhalation of toxic fumes, and burns. This protective equipment includes but is not limited to:

- Protective eyewear, and hearing protection.
- Respirators, protective clothing, and gloves as recommended by the fluid and solvent manufacturer.

**PRESSURIZED ALUMINUM PARTS HAZARD**

Use of fluids that are incompatible with aluminum in pressurized equipment can cause serious chemical reaction and equipment rupture. Failure to follow this warning can result in death, serious injury, or property damage.

- Do not use 1,1,1-trichloroethane, methylene chloride, other halogenated hydrocarbon solvents or fluids containing such solvents.
- Do not use chlorine bleach.
- Many other fluids may contain chemicals that can react with aluminum. Contact your material supplier for compatibility.

Component Identification (typical installation)

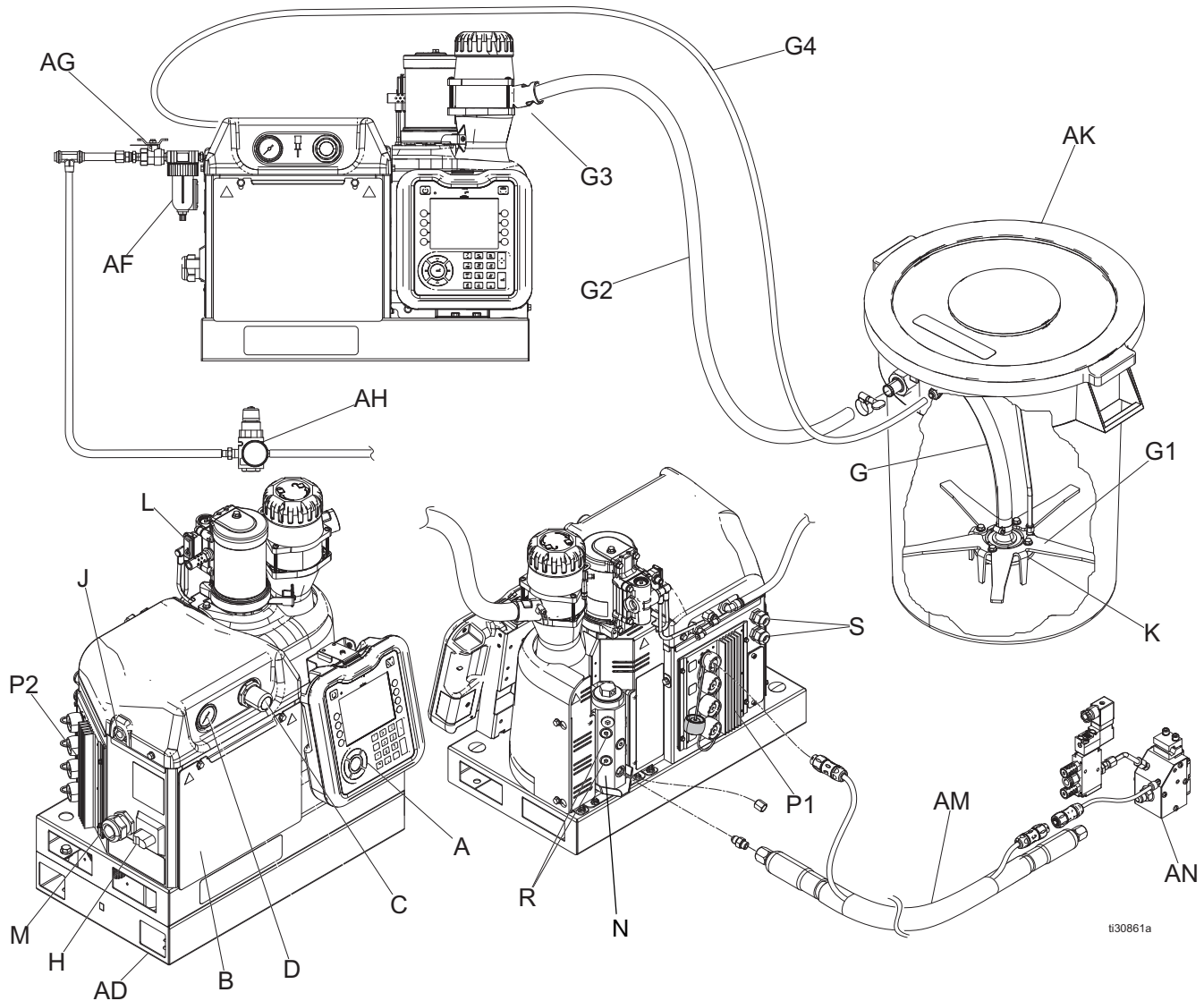

Ref.	Description
A	Advanced Display Module (ADM)
AD	Transformer Base
AF	System Inlet Air Filter
AG	System Inlet Air Ball Valve
AH*	Applicator Air Regulator
AK*	Feed Bin
AM*	Heated Hose
AN*	Applicator
B	Electrical Enclosure
C	Pump Air Pressure Regulator
D	Pump Air Pressure Gauge
G*	Shaker Tube
G1*	Shaker Head
G2*	Feed Tube

Ref.	Description
G3	Feed Inlet Funnel
G4*	3/8 in. OD Air Supply Feed Hose
H	Main Power Switch
J	System Air Inlet
K	Vacuum Transfer (Shaker) Inlet
L	Air Motor and Pump
M	Incoming Power Strain Relief
N	Heated Fluid Manifold (Melter)
P	Automatic Multi-Zone (AMZ)
P1	Automatic Multi-Zone 1 (AMZ 1)
P2	Automatic Multi-Zone 2 (AMZ 2)
R	Fluid Outlets for connection to Heated Hoses
S	Customer I/O Cable Gland

* Not supplied with InvisiPac HM25c (sold separately).

Setup

Grounding



The equipment must be grounded to reduce the risk of static sparking and electric shock. Electric or static sparking can cause fumes to ignite or explode. Improper grounding can cause electric shock. Grounding provides an escape wire for the electric current.

The InvisiPac system is equipped with a ground terminal. A qualified electrician must ground the system using this terminal. See **Connect Electrical Cord** on page 20.

Location

When setting up the InvisiPac system, make sure it meets the following criteria:

- Ambient temperature must be 32°-120° F (0°-49° C).
- The InvisiPac system must be located to allow the feed hose to reach the feed bin (AK). The length of feed hose supplied with each feed system is 10 ft (3 m). The maximum recommended feed hose length is 30 ft (9.1 m). Use **30 ft Feed Hose, 24R043** to achieve the maximum feed hose length.
- The InvisiPac system must be located to allow the heated hoses (AM) to reach from the melter (N) to the applicators. The maximum length of an InvisiPac hose is 25 ft (7.6 m).
- For ease of operation, place the InvisiPac system with the display slightly below eye-level. Use **System Stand Kit, 17S264** to locate the InvisiPac system at the appropriate height. See page 70 for details.
- Use **Adapter Plate Kit, 25M528** (page 70) to locate the InvisiPac system in place of a non-Graco system.
- For ease of operation and maintenance, position the InvisiPac system so that all sides are easily accessible and have sufficient lighting.
- Permanently fasten the system base in the location selected using the mounting holes provided. See **Mounting Hole Dimensions** on page 113.

Connect Feed System

1. Refer to the instruction manual supplied with the feed system for any assembly steps required prior to connecting the feed system to the InvisiPac system.
2. Adjust the funnel inlet (79) on the InvisiPac system (optional):
 - a. Loosen all three tie bolts (87).

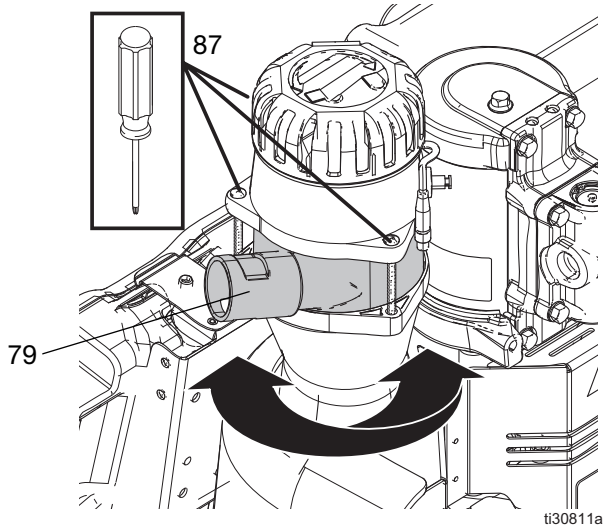

- b. Rotate the funnel inlet (79) to the desired position and re-tighten all three tie bolts (87).

3. Insert 1.3 in. (33 mm) OD clear feed hose (G2) into the funnel inlet (79). Tighten the hose clamp over the cutouts in the funnel inlet to secure the feed hose.

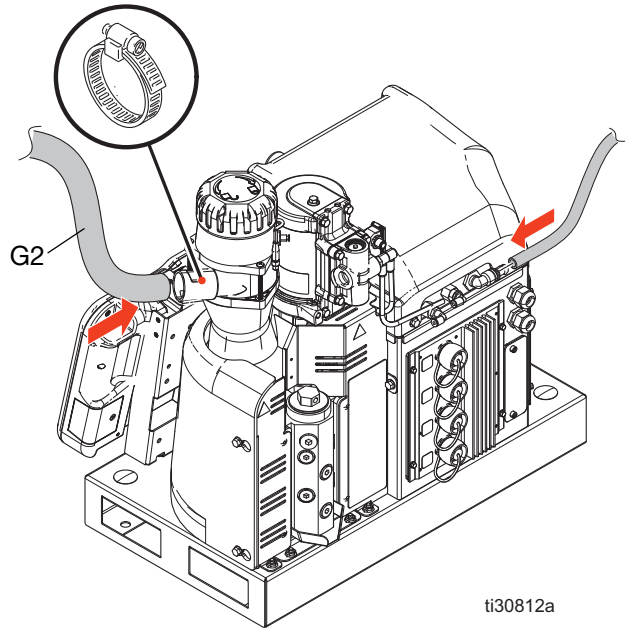

4. Connect the 3/8 in. (9.525 cm) OD air supply feed hose (G4) to the empty 3/8 in. (9.525 cm) push-to-connect fitting on the back of the InvisiPac system.

Connect Heated Hoses



The equipment surfaces and components can become very hot. To avoid severe burns, wear protective equipment, such as thermally insulated gloves.

To help prevent serious injury from pressurized fluid, such as skin injection, follow the “Pressure Relief Procedure” on page 26 before connecting a hose to the equipment.

Use of a Graco heated hose is not required with this system. However, all heated hoses attached to the system must be rated for 1200 psi (8.3 MPa, 83 bar), 400° F (204° C), have an RTD type sensor, and use no more than 1250W at 240 VAC. Non-Graco heated hoses require an electrical adapter cable.

If connecting hoses to a system already in service: perform **Pressure Relief Procedure** on page 26, and ensure system is at a safe temperature to perform work, then proceed to step 2.

If connecting hoses to a new system: begin with step 1.

1. Drain any residual oil from factory testing:
 - a. Place a rag on the melter drain tray (650). Residual oil may remain in the system from factory testing.
 - b. Use a 1/4 in. Allen wrench to remove the drain port plug (640).
 - c. When fluid stops draining, reinstall the drain port plug (640) and remove the rag from the melter drain tray (650).
2. Make a fluid connection between the system and the heated fluid hose.

NOTE: For ease of installation, use the bottom melter ports first.

NOTE: Do not use the top port (PT) for hose fluid connections.

Remove the melter outlet cap.

- a. Install a port connector (345, 346, or 347) on each melter fluid outlet. Torque to 15 ft. lbs.

NOTICE

Over-tightening the hose port connector will damage the connector seal and cause fluid leaks. Do not overtighten the port connector. Use two wrenches to torque the hose to the melter pump.

- b. Connect the heated hose to the melter fluid outlet starting with the bottom port. Use two wrenches to torque the hose to 300 in-lb. See FIG. 1.

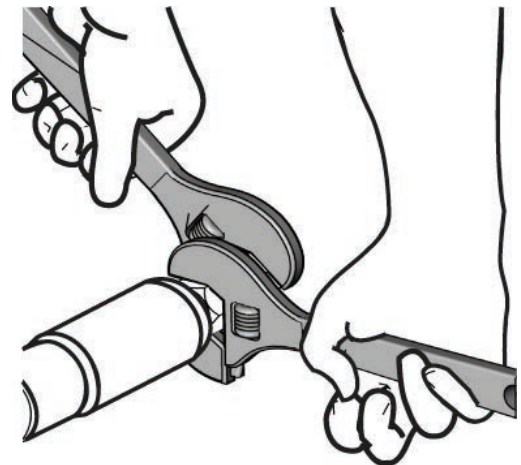

FIG. 1: Heated Hose to Fluid Port Connector

3. Repeat the previous step for all remaining hoses.
4. Make electrical connection between heated hose(s) and AMZ(s):

NOTE: For ease of installation, make connections between the rightmost melter ports and the rightmost AMZ electrical connectors first.

- a. Remove the cap (CP) from the AMZ electrical connector and install the hose electrical connector (HC).
5. Repeat the previous step for all remaining hoses. See FIG. 2 page 12.

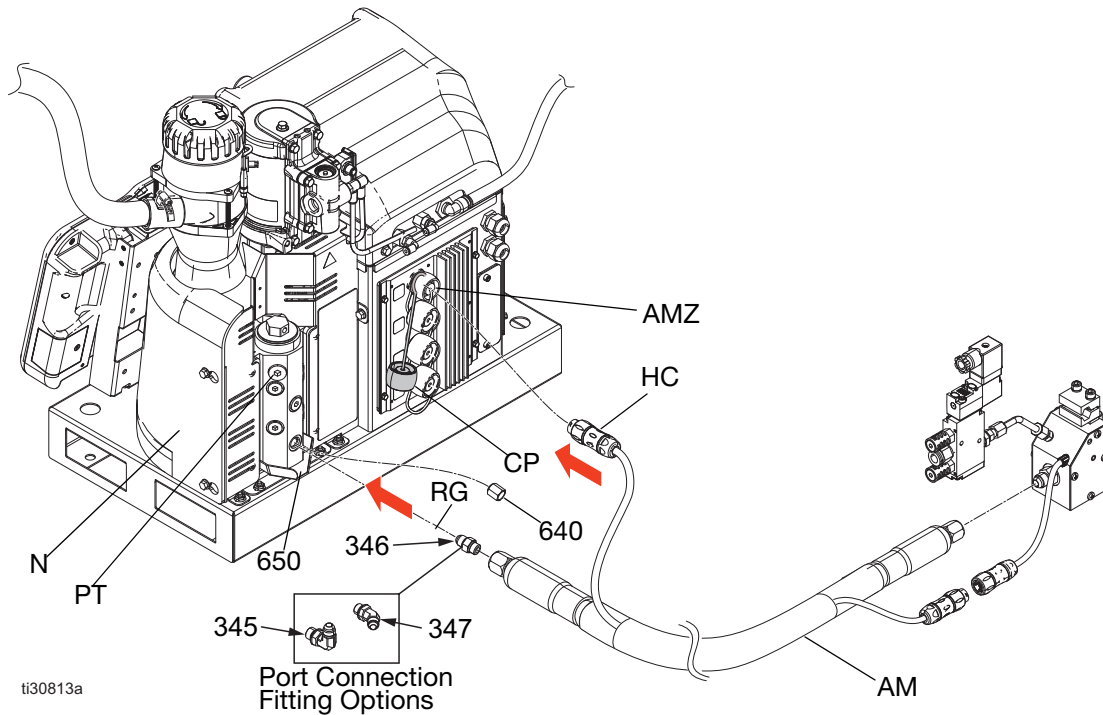

FIG. 2:

Connect Applicators



Use of a Graco applicator is not required with this system. However, all applicators attached to the system must be rated for 1200 psi (8.3 MPa, 83 bar), 400° F (204° C), have an RTD type sensor, and use no more than 400W at 240 VAC. Non-Graco applicators require an electrical adapter cable.

If connecting applicators to a system already in service: perform **Pressure Relief Procedure** on page 26, and ensure system is at a safe temperature to perform work.

1. Use a 11/16 in. wrench to tighten the heated hose fluid outlet (FD) to applicator fluid inlet to make a fluid connection between the heated hose (AM) and applicator (AN).
2. Make an electrical connection between the heated hose (AM) and the applicator (AN):

- a. For connecting Graco heated hoses to Graco applicators, attach the heated hose electrical connector (HHE) to the applicator electrical connector (AEC).
 - b. For connecting Graco heated hoses to non-Graco applicators, attach a heated hose applicator adapter cable and connect the other end to the applicator electrical connector (AEC).
3. Repeat the previous steps for all remaining applicators.

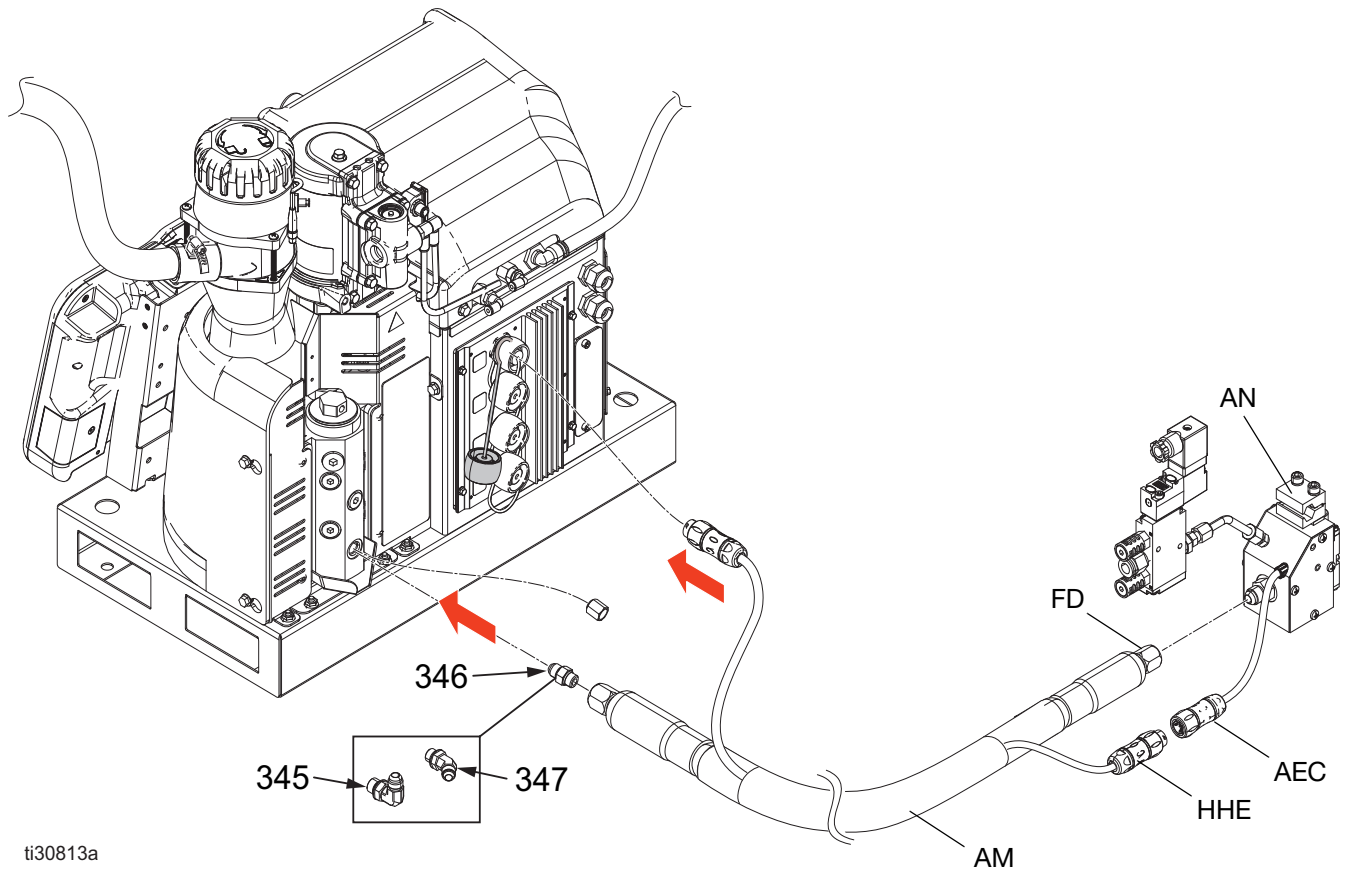

ti30813a

Connect Air Supply

See **Connecting the Air Supply** on page 15 for recommended air setup guidelines before continuing the remaining steps.

NOTE: The system must use a bleed-type ball valve that bleeds pressure downstream when closed.

NOTE: The system must use an air filter with a minimum flow rate of 30 scfm.

NOTE: The system air gauge lenses are plastic to allow for use in food and beverage industries.

Oiling the air supply can reduce the life of the air controls components. Do not install an oiler on the air supply to the system.

1. Install the supplied air inlet bleeding ball valve (366) and air filter (AF) at the 1/4 NPT female system air inlet.

NOTE: Additional fittings provided with the inlet air kit are optional and may be used as required.

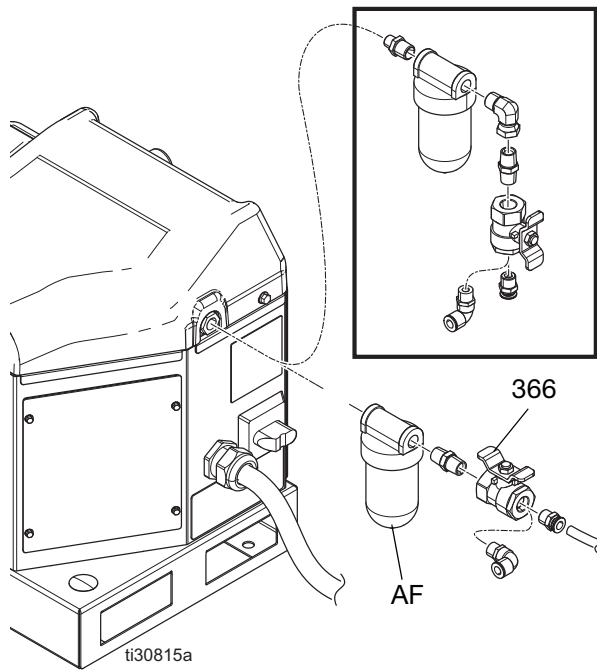

2. Close the ball valve (366).

NOTE: If using the same air for actuating the applicator(s), install the tee in the air supply line before the ball valve. See the applicator manual for applicator air pressure requirements. If necessary, use a regulator before the applicator to decrease air pressure.

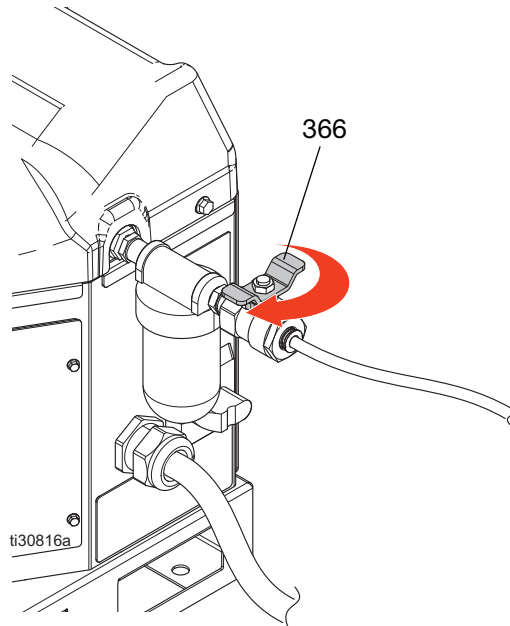



3. Connect a 3/8 in. (9.525 cm) minimum air supply line to the ball valve (366).

NOTE: For best performance, supply pressure should be between 80 psi (550 MPa, 5.5 bar) and 100 psi (690 MPa, 6.9 bar). If air supply is not able to sustain pressure at the flow rate required by the InvisiPac system, or if pressure is expected to drop due to other equipment sharing the supply, an Air Reservoir Kit 16W366 is available that allows the system to operate on lower pressure or restricted air supply lines.

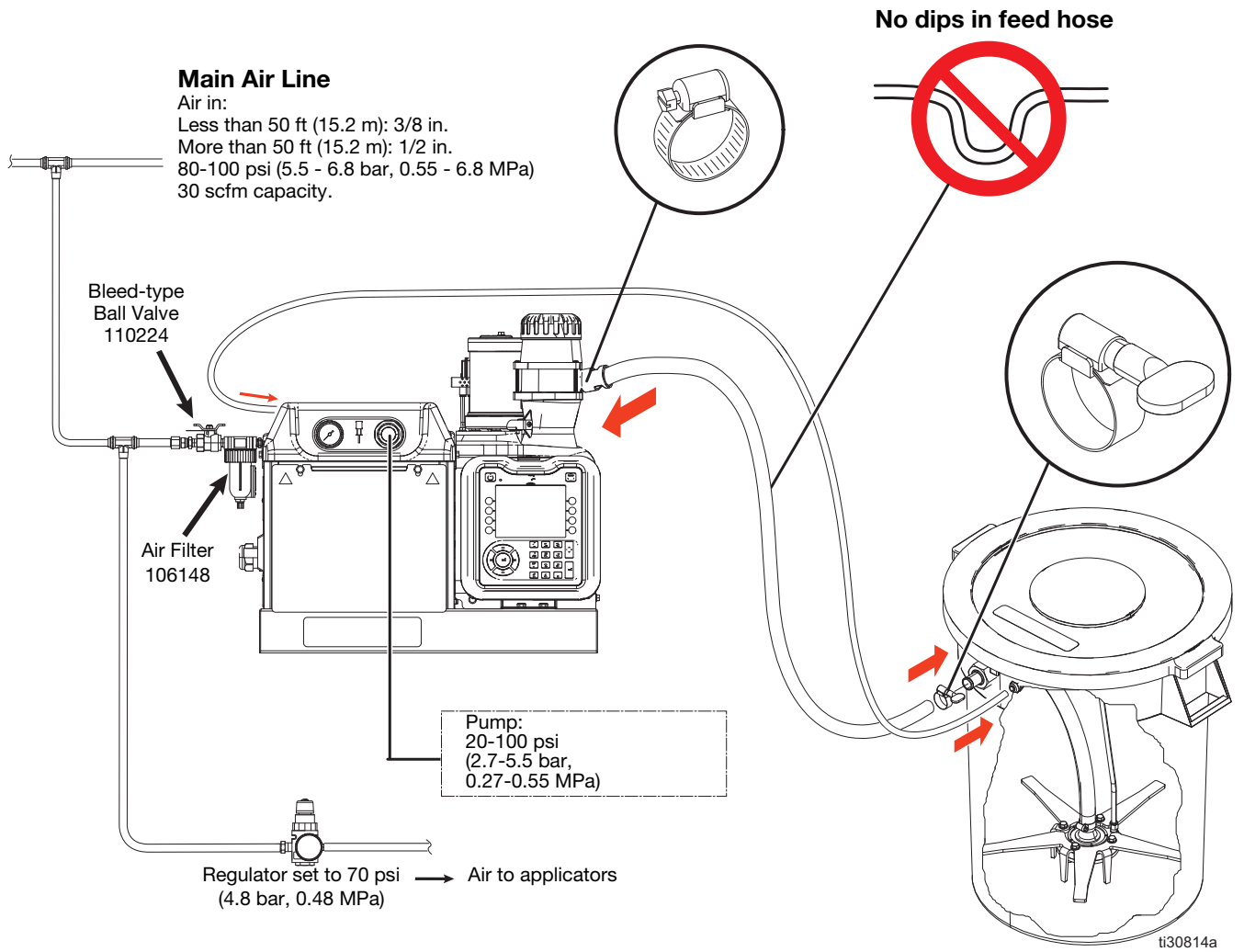
Connecting the Air Supply (typical installation)



Connect PLC Inputs

				
<p>DANGER</p> <p>SEVERE ELECTRIC SHOCK HAZARD</p> <p>This equipment can be powered by more than 240V. Contact with this voltage will cause death or serious injury.</p> <ul style="list-style-type: none"> • Turn off and disconnect power at main switch before disconnecting any cables and before servicing equipment. 				

Each InvisiPac system is equipped with six PLC inputs. Each input can be configured in software to perform one of the following options:

- Turn the InvisiPac system on/off
- Disable the InvisiPac system (turn off the pump)
- Enable/Disable individual channels (1 - 8)

NOTE: See **Appendix A - ADM** on page 80 for detailed information regarding software configuration of the options above.

NOTE: Additional PLC inputs are available on InvisiPac systems containing an internal pattern controller. Refer to the Pattern Control System manual 334784 for more detail.

The InvisiPac PLC inputs accept the input types below:

Input Type	Specifications
Digital Input	0-30 VDC Signal Low: 0-2.5 V Signal High: 10-30 V
Dry Contact	Open/Closed Circuit Signal Low: Open Circuit Signal High: Closed Circuit

Wire the PLC Inputs

1. Route a multi-conductor cable through one of the cable grommets (CG) on the back of the InvisiPac system enclosure.

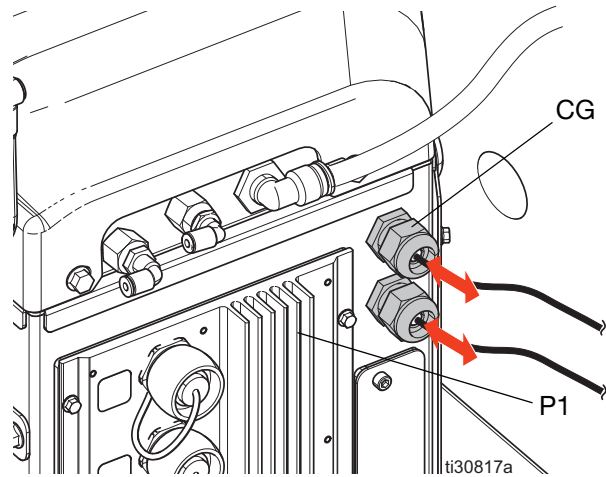

2. Refer to the following sections (**Digital Inputs** and **Dry Contact Inputs**, depending on the input type needed) to wire the PLC inputs to the System I/O Board on AMZ #1 (P1).

NOTE: On 8-channel InvisiPac systems, an additional System I/O board is included on AMZ #2 (P2). Do not wire PLC inputs to the System I/O Board on AMZ #2.

Digital Inputs (0 - 30 VDC)

1. Connect the PLC GND wire (16-28 AWG) to the "ISO GND" terminal on J9.
2. Connect the input signal wire to the desired input terminal on J9 (labeled by input number).
3. Repeat step 2 for remaining inputs.

The system I/O board and/or the PLC could become damaged if connections are made to J8. Do not connect any wires to J8 while using Digital Input type PLC inputs. Signals on J8 are provided for Dry Contact type inputs only.

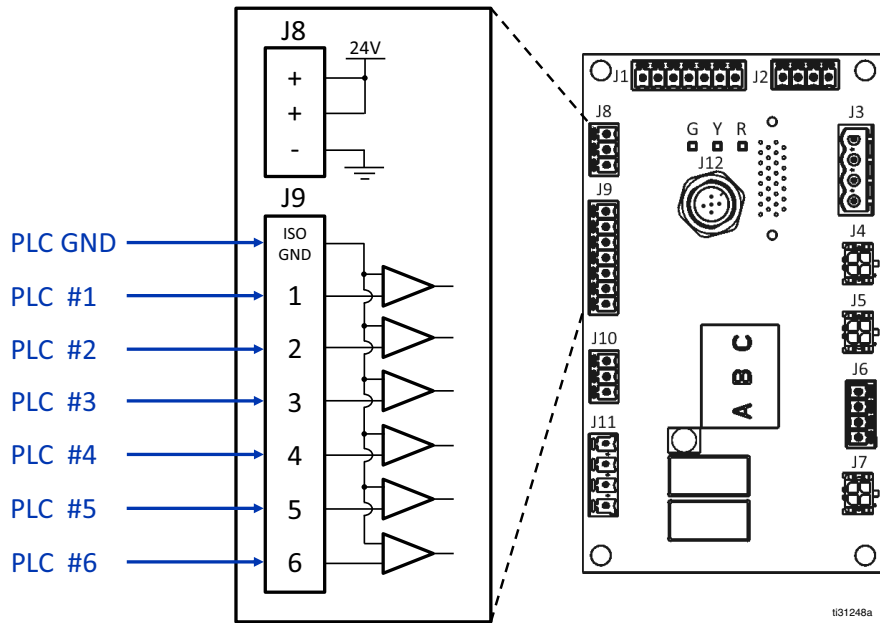

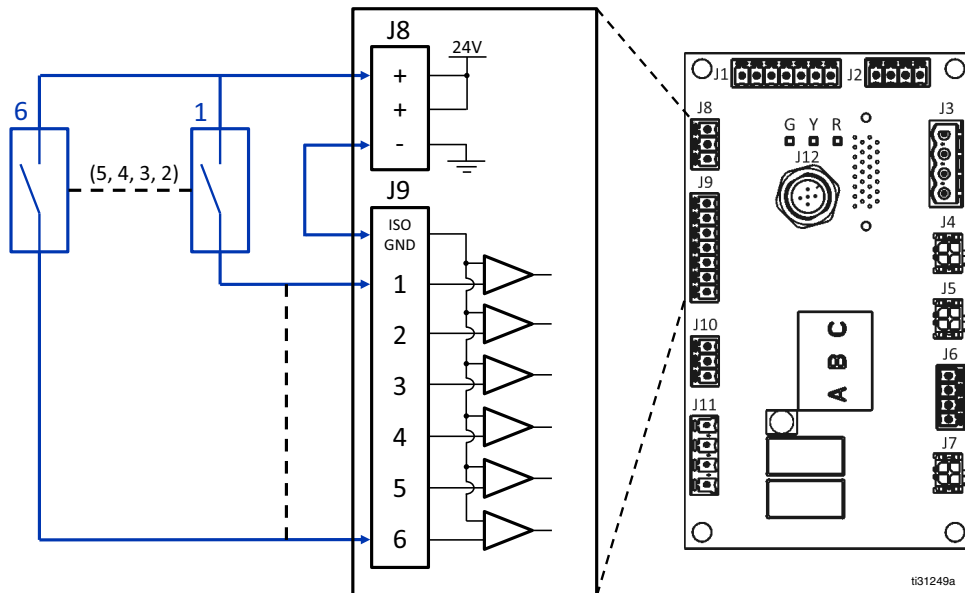

Dry Contact Inputs (Open/Closed Circuit)

1. Connect a jumper wire (16-28 AWG) between "-" terminal on J8 and "ISO GND" terminal on J9.
2. Connect one side of the input to one of the "+" terminals on J8.
3. Connect the other side of the input to the desired input terminal on J9 (labeled by input number).
4. Repeat steps 2 and 3 for remaining inputs.



Connect PLC Outputs

				
<p>DANGER</p> <p>SEVERE ELECTRIC SHOCK HAZARD</p> <p>This equipment can be powered by more than 240V. Contact with this voltage will cause death or serious injury.</p> <ul style="list-style-type: none"> Turn off and disconnect power at main switch before disconnecting any cables and before servicing equipment. 				

Each InvisiPac system is equipped with two PLC outputs. Each output can be configured separately in software to indicate the following states:

- InvisiPac System Ready
- Error Present
- Maintenance Due

NOTE: See **Appendix A - ADM (Advanced Display Module)** on page 80 for detailed information regarding software configuration of the options above.

NOTE: Additional PLC outputs are available on InvisiPac systems containing an internal pattern controller. Refer to the Pattern Control System manual 334784 for more detail.

The InvisiPac PLC outputs have the following specifications:

Item	Specification
Output Type	Dry Contact (Open/Close Circuit)
Max Voltage	24 VDC / 240 VAC
Max Current	2A

Wire the PLC Outputs

- Route a multi-conductor cable through one of the cable grommets (CG) on the back of the InvisiPac system enclosure.

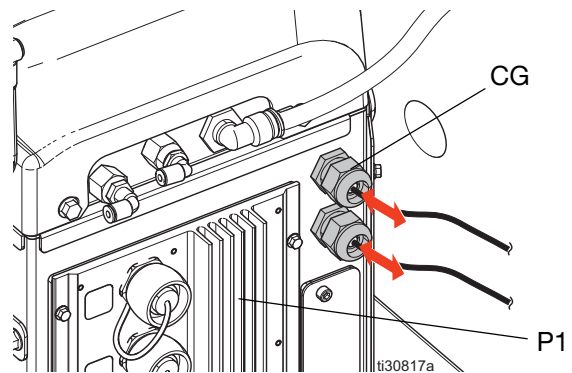

- Refer to the image below to wire PLC outputs to the system I/O Board on AMZ #1 (P1).

NOTE: On 8-channel InvisiPac systems, an additional System I/O board is included on AMZ #2 (P2). Do not wire PLC outputs to the System I/O Board on AMZ #2.

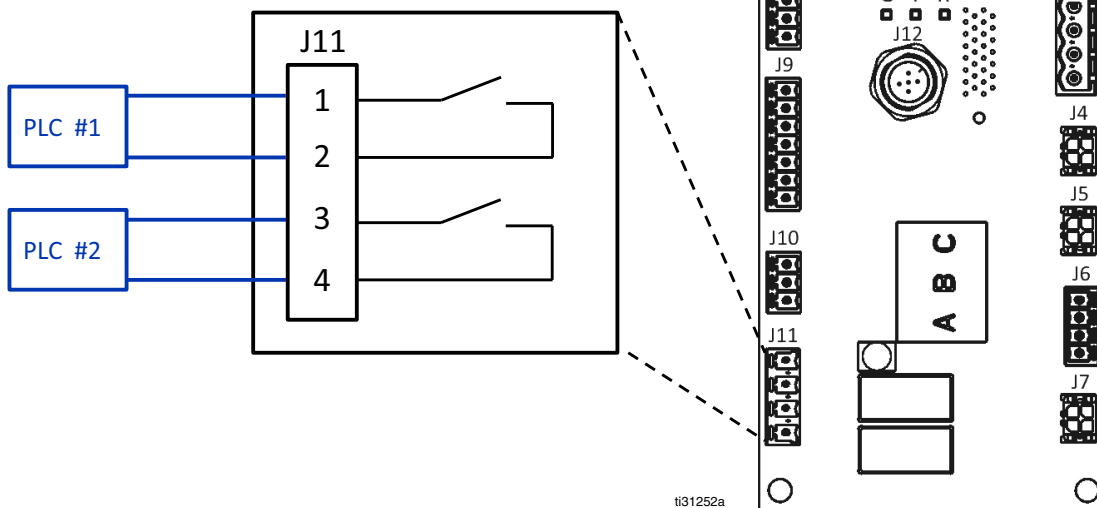

Connect Material Tracking Input



DANGER
SEVERE ELECTRIC SHOCK HAZARD
 This equipment can be powered by more than 240V. Contact with this voltage will cause death or serious injury.

- Turn off and disconnect power at main switch before disconnecting any cables and before servicing equipment.

A trigger sensor or dry contact input can be used to add material tracking to InvisiPac HM25c systems that do not contain a pattern controller. See **Accessories** (starting on page 70) for additional details.

NOTE: InvisiPac HM25c systems with an integrated pattern controller track material usage per unit automatically and do not require an additional trigger sensor or dry contact input.

NOTE: See **System Screen 4 - Material Tracking Setup** on page 90 for detailed information regarding how to view setup and material tracking information in the software.

Perform the following steps to connect a trigger sensor to the InvisiPac system:

1. Mount the trigger sensor according to the guidelines in the table below:

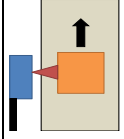
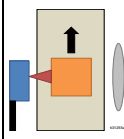
Kit	Sensor Type	Notes	Image
24X446	Diffuse	<ul style="list-style-type: none"> • Align sensor perpendicular to line. • Adjust sensitivity for proper operation. • Ensure sensor trips once per unit. • Range: 200 mm 	
24X447	Retro Reflective	<ul style="list-style-type: none"> • Align sensor perpendicular to line. • Align reflector and sensor. • Ensure sensor trips once per unit. • Range: 3.5 mm 	

2. Connect the M12 end of the supplied cable to the trigger sensor.

3. Route the flying lead end of cable through one of the cable grommets (CG) on the back of the InvisiPac electrical enclosure.

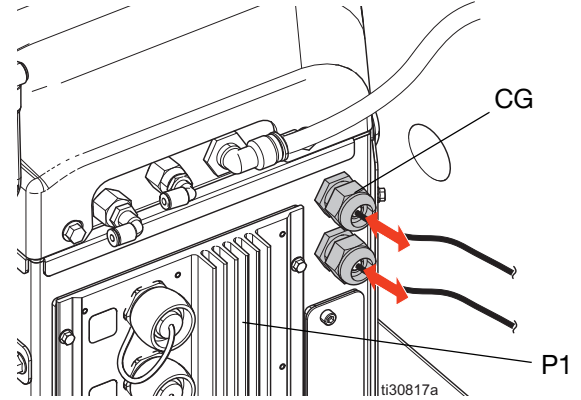

4. Refer to the table and image below to connect flying leads to the System I/O Board on AMZ #1 (P1).

NOTE: On 8-channel InvisiPac systems, an additional System I/O board is included on AMZ #2 (P2). Do not wire the trigger sensor to the System I/O board on AMZ #2.

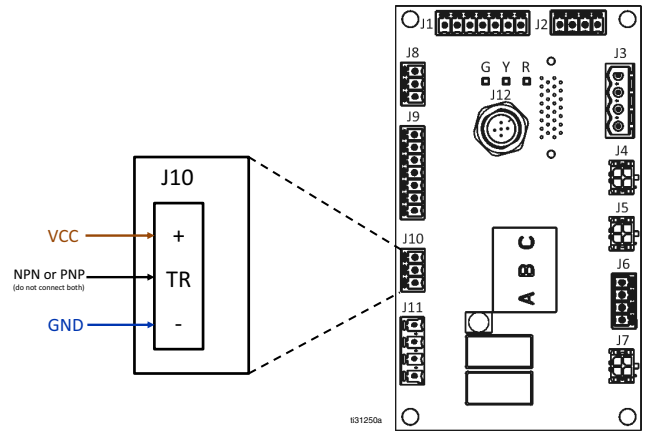

Flying Lead Signal (color)	J10 Pin
VCC (brown)	+
PNP (black)	TR*
NPN (white)	
GND (blue)	-

***NOTE:** Only connect one wire (trim and terminate the other wire).

Setup

Perform the following steps to connect a dry contact to the InvisiPac system:

1. Route cable through one of the cable grommets (CG) in back of the InvisiPac electrical enclosure.
2. Refer to the table and image below to connect flying leads to the System I/O Board on AMZ #1.

NOTE: On 8-channel InvisiPac systems, an additional System I/O board is included on AMZ #2. Do not wire the dry contact input to the System I/O board on AMZ #2.

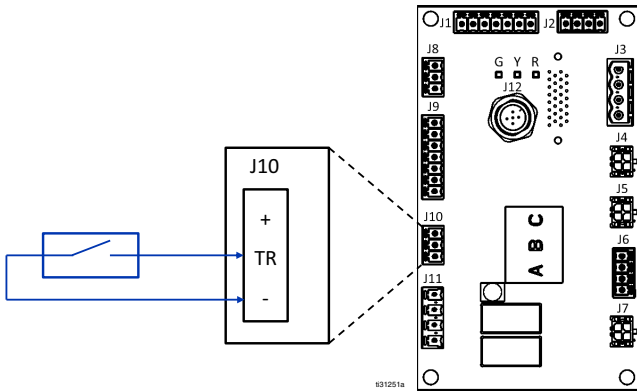

Connect Accessories

See **Accessories** (starting on page 70) for additional kits and installation instructions.

Connect Electrical Cord



DANGER SEVERE ELECTRIC SHOCK HAZARD

This equipment can be powered by more than 240V. Contact with this voltage will cause death or serious injury.

- Turn off and disconnect power at main switch before disconnecting any cables and before servicing equipment.
- This equipment must be grounded. Connect only to grounded power source.
- All electrical wiring must be done by a qualified electrician and comply with all local codes and regulations.
- To reduce the risk of electric shock, perform the previous **Setup** sections (beginning on page 9) prior to connecting the electrical cord.

NOTE: The installed strain relief bushing (SR) fits a 0.71-0.98 in. (18-25 mm) OD electrical cord.

1. Turn the main power switch (H) OFF.

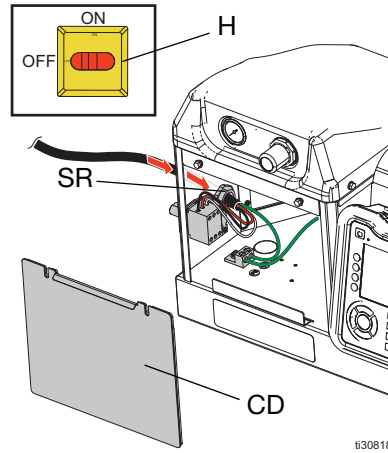

2. Remove the electrical enclosure door (CD).
3. Insert the electrical cord through the electrical enclosure strain relief bushing (SR).
4. Attach insulated ferrules to the end of each wire.
5. Connect ground wire to the chassis ground.
6. Connect power wires to the main power switch as shown below.

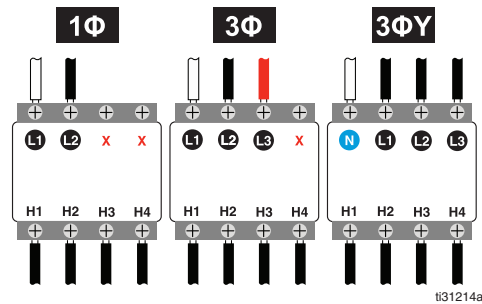







NOTE: Use a flat-head or Pozidriv screwdriver to tighten terminals to at 7-10 in-lb (0.8-1.1 N•m).

7. Tighten strain relief bushing (SR) around electrical cord.
8. Install the electrical enclosure door (CD).

Select ADM Settings

NOTE: The following steps involve the minimum ADM settings required to startup the system. See **Appendix A - ADM** on page 80 for detailed information.

1. Turn main power switch (H) on .
2. Once the ADM has finished starting up, press  to switch from the Operation screens to the Setup screens. Use , , , and  to navigate between screens.

3. On **System Screen 1 - Gun Setup:**

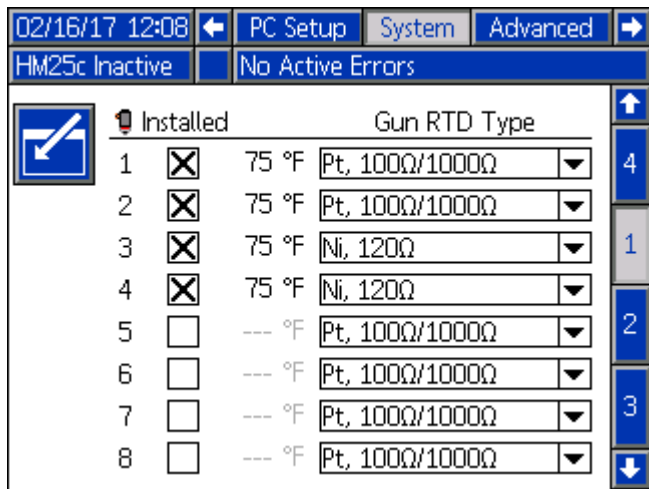

	Installed	Temp	Gun RTD Type
1	<input checked="" type="checkbox"/>	75 °F	Pt, 100Ω/1000Ω
2	<input checked="" type="checkbox"/>	75 °F	Pt, 100Ω/1000Ω
3	<input checked="" type="checkbox"/>	75 °F	Ni, 120Ω
4	<input checked="" type="checkbox"/>	75 °F	Ni, 120Ω
5	<input type="checkbox"/>	--- °F	Pt, 100Ω/1000Ω
6	<input type="checkbox"/>	--- °F	Pt, 100Ω/1000Ω
7	<input type="checkbox"/>	--- °F	Pt, 100Ω/1000Ω
8	<input type="checkbox"/>	--- °F	Pt, 100Ω/1000Ω

- a. Check the box in the “Installed” column for each channel that has a heated hose and gun (applicator) installed.
- b. Select the RTD type used on each installed gun (applicator). Refer to the applicator manual for details on RTD type selection.



To prevent fire and explosion, a qualified electrician must determine the proper circuit breaker size to use for the power supplied to the system.

4. On **System Screen 2 - General Setup:**

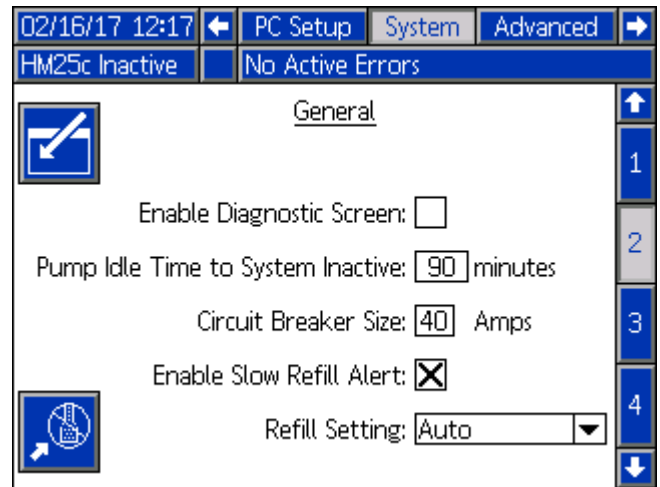

02/16/17 12:17 PC Setup System Advanced

HM25c Inactive No Active Errors

General

Enable Diagnostic Screen:

Pump Idle Time to System Inactive: 90 minutes

Circuit Breaker Size: 40 Amps

Enable Slow Refill Alert:

Refill Setting: Auto

- a. Enter the main circuit breaker size used. This is the circuit breaker in-line with main power supplied to the system (external to the system, provided by the end user).

NOTE: The system limits current draw on incoming power lines based on the circuit breaker size entered. The minimum value for the setting is 15 A, and a larger circuit breaker will allow the system to draw more power and reduce startup time (see **Startup Time** on page 117). See **Models** on page 4 for maximum system current draw.

5. On **Advanced Screen 1 - Display Settings:**

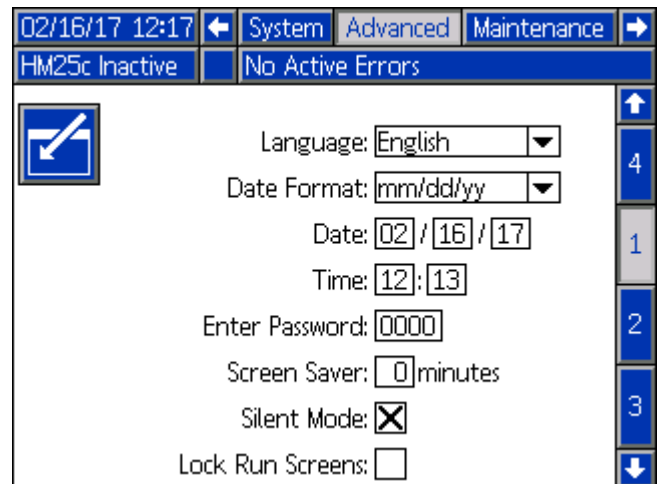

02/16/17 12:17 System Advanced Maintenance

HM25c Inactive No Active Errors

Language: English

Date Format: mm/dd/yy

Date: 02 / 16 / 17

Time: 12 : 13

Enter Password: 0000

Screen Saver: 0 minutes

Silent Mode:

Lock Run Screens:

- a. Set the display language, date and time.

6. On **Advanced Screen 2 - Display Units:**

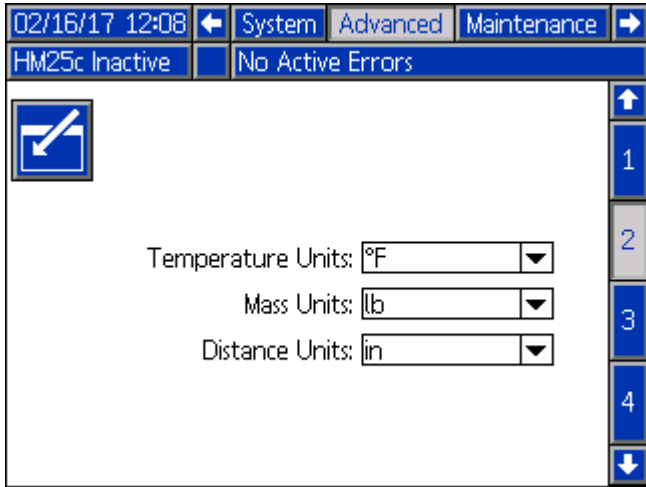

- a. Set the temperature and mass units.

NOTE: Distance units are used by systems with integrated pattern controller only.

- 7. *If desired*, set any remaining settings in the Setup screens before returning to the Operations screens in the following steps. These additional settings are not required for basic system operation, but include some useful functions. See **Appendix A - ADM**

(Advanced Display Module) on page 80 for detailed information about each setting.

- 8. Press to switch from the Setup screens to the Operation screens. Use , , , and to navigate between screens.

9. On **Targets Screen(s):**

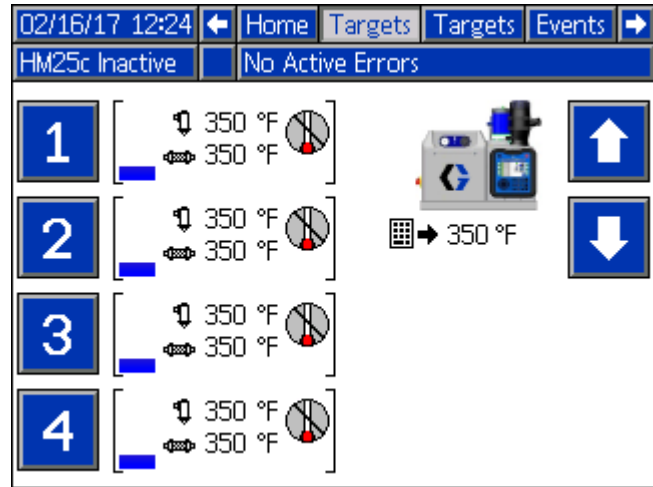

- 10. Use and , or the number pad to enter the melter, hose and applicator temperature setpoints.

Operation



Heating and dispensing hot melt adhesive may create potentially harmful vapors. Read material manufacturer's warnings and material SDSs to know specific hazards and precautions. Ventilation of the work area may be required.

NOTE: See **Appendix A - ADM (Advanced Display Module)** on page 80 for detailed ADM information.

NOTE: See **Appendix B - USB Downloading** on page 93 for detailed USB information.

Overview

The system uses a vacuum transfer system (feed system) that pulls the adhesive pellets into the system as needed. Once melted, the adhesive enters the pump where it is pumped into the heated hoses and finally the heated applicators. The applicator then briefly opens to dispense the desired amount of adhesive.

Initial Startup and Prime

NOTE: All setup procedures must be completed prior to initial startup. See **Setup** on page 9.

1. Direct the applicator into an appropriate waste container.
2. Verify the shaker inlet (K) is at the bottom of the feed bin (AK).
3. Fill feed bin (AK) with hot melt adhesive pellets.

4. Turn main power switch (H) on .
5. Open system air inlet ball valve (366).

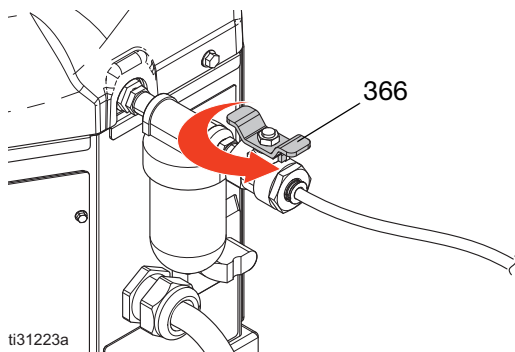

6. Use pump air pressure regulator (PP) to adjust pump air pressure to 0.

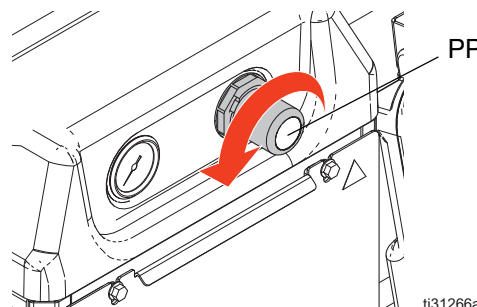

NOTE: Feed system will not begin to feed pellets until the system reaches operating temperature.



To prevent fire and explosion, never exceed the cleaning fluid's rated temperature. If the system was just flushed, residual cleaning fluid is still in the system until the system is primed with adhesive. Do not raise temperature above cleaning fluid rated temperature until system is primed with adhesive.

7. *On new systems only:* A new system may have residual oil in the melter from factory testing prior to shipping. To prevent smoking, temporarily adjust the melter temperature to 250°F (121°C). See **Appendix A - ADM (Advanced Display Module)** on page 80 for details.

8. Press  to begin system warm-up.

NOTE: Once the system is up to temperature, the pump will be activated automatically. However, the pump will not start since there is no air pressure supplied to the pump.

NOTE: Once the system is up to temperature, the feed system will fill the melter with pellets.

9. *On new systems only:* After the system has reached temperature and the melter is filled with pellets, set the melter temperature to the desired temperature. See **Appendix A - ADM (Advanced Display Module)** on page 80 for details.

10. Use pattern controller or manual triggering method to open the applicators and keep them open. If system includes an InvisiPac pattern controller, see the **InvisiPac Pattern Controller** manual for details on purging using the ADM.

11. With the applicators open and the system up to temperature, slowly increase the pump air pressure (PP) until the pump begins to run very slowly. Approximately 20 psi (140 MPa, 1.4 bar) should be sufficient.

To prevent damage to the pump due to pump cavitation, do not supply more than 20 psi (140 MPa, 1.4 bar) air pressure to the pump until the system is fully primed.

NOTE: Pump operation may be erratic below 20 psi (140 MPa, 1.4 bar).

12. Continue running the pump until clean, air-free material is dispensed from each applicator.
13. Once each applicator is fully primed, adjust pump to desired pressure setting.
 - a. Adjust pump pressure to 20-100 psi (140-690 MPa, 1.4-6.9 bar).
 - b. Use pattern controller to repeatedly open and close each applicator while inspecting the dispense pattern.
 - c. Repeat until desired dispense pattern is achieved.

Automatic Refill

The system uses automatic refill by default. If the automatic refill system is unable to feed pellets to the system and cannot be fixed immediately, **Manual Refill** can be used.

To use automatic refill:

1. Verify feed system is connected (see **Connect Feed System**, page 10).
2. Navigate to **System Screen 2 - General Setup** and select “Auto” or “Auto Adapting” from the “Refill Setting” dropdown (see **Appendix A - ADM (Advanced Display Module)** on page 80 for details).
3. System will automatically refill pellets into the melter when adhesive level drops below the refill threshold.

NOTE: During the refill process, the feed solenoid is turned on and off repeatedly to regulate the flow of pellets. For each subsequent refill, the system

adjusts length of these air pulses to refill at an exact rate each time.

4. A refill timeout alarm will appear on the ADM screen if refill is unable to complete.

Manual Refill

NOTE: Only use Manual Refill if the Automatic Refill system is not functioning properly and cannot be fixed in a timely manner. Perform service to the automatic feed system as soon as possible to limit debris buildup on the feed funnel.

It is recommended to maintain a minimum flow rate of 1.5 lb/hour to prevent material from melting within the feed cap and funnel. If production rate is below 1.5 lb/hour or system sits at temperature without dispensing for extended periods of time, use manual refilling with caution. System flow rate can be monitored on the Diagnostic Screen (see **Appendix A - ADM (Advanced Display Module)** on page 80 for details).

1. Navigate to **System Screen 2 - General Setup** and select “Manual” from the “Refill Setting” dropdown (see **Appendix A - ADM (Advanced Display Module)** on page 80 for details).
2. Remove the three bolts (87) shown below. Then remove the top portion of the funnel (81).

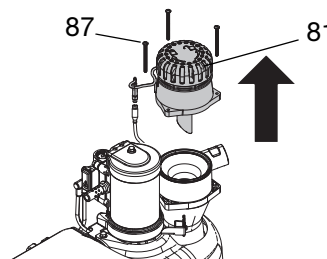

3. Fill the funnel with adhesive pellets.

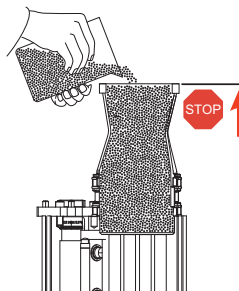

4. Refill the funnel as needed to maintain the required flow rate.
5. Prior to shutting off the system, dispense into a waste container until the material level is down into

the melter core. This will ensure all melted pellets re-melt when the system is re-heated.

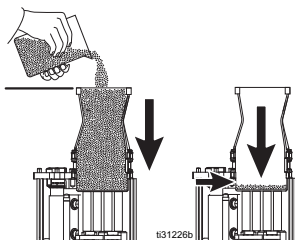

Dispense

NOTE: Only hot melt adhesive pellets can be used in the InvisiPac system.

1. If the system is empty or has air in the lines, perform **Initial Startup and Prime** procedure on page 23.
2. If main power switch (H) is OFF, turn main power switch ON



NOTE: The main power switch (H) should be left ON at all times when using the Schedule function.

3. Prepare for dispensing:
 - a. Verify air inlet ball (AG) is open.
 - b. Check pump air pressure gauge (D) to verify pressure is set as desired.
 - c. If using **Automatic Refill**, see page 24.
 - d. If using **Manual Refill**, see page 24.
 - e. Verify applicators are closed.

4. Press  to enable the heaters and pump.

NOTE: If using the Schedule function, the heaters and pump will be enabled automatically at the set time. You will not need to press  if using the Schedule function unless you wish to enable the heating system before the set time.



NOTE: When the system is up to temperature, the pump will begin running automatically. It will stall at pressure unless an applicator is open. Material will be dispensed whenever an applicator is open after the system is up to temperature.

5. When the system is up to temperature, use pattern controller to open and close the applicators as desired to dispense material.

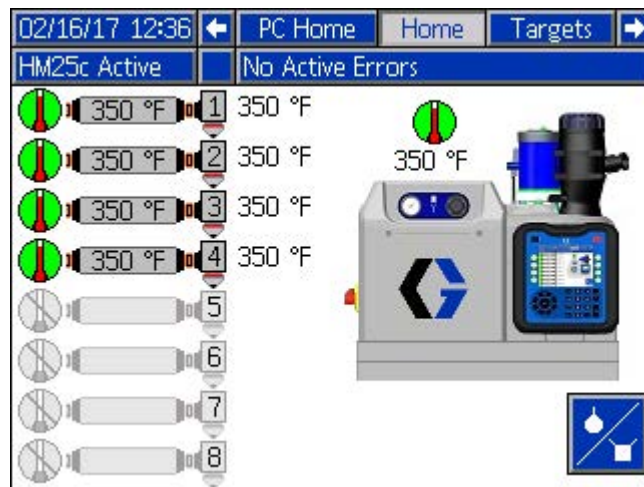
NOTE: While operating the system, the actual temperatures of the hose, applicator, and system melter are displayed on the Home screen.



Shutdown

Press  to disable the heaters and pump. The screen will say “Inactive”. If using the Schedule function, the heaters and pump will be disabled automatically at the set time. You will not need to press  if using the Schedule function unless you wish to disable the heating system before the set time. If the heaters were manually disabled, the Schedule function will automatically enable them at the next set time.

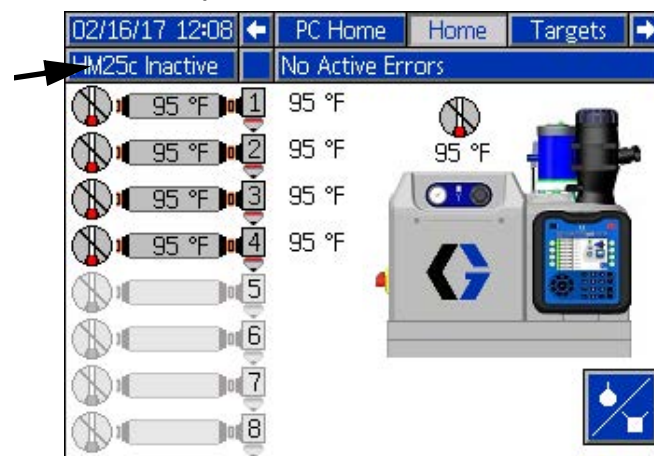

Do not turn the main power switch (H) OFF if using the Schedule function.

Schedule

The Schedule function allows the user to specify times when the system will automatically turn the heaters and pump ON and OFF.

02/16/17 12:17		Maintenance	Schedule	PC Setup				
HM25c Inactive		No Active Errors						
	Mon	Tue	Wed	Thu	Fri	Sat	Sun	
	06:45	06:45	06:45	06:45	06:45			
	11:30	11:30	11:30	11:30	11:30			
	12:20	12:20	12:20	12:20	12:20			
	16:30	16:30	16:30	16:30	16:30			

Set Schedule Times

NOTE: Times are set using a 24-hour clock. Several on and off times can be set each day.

1. On the Schedule screen (in the Setup screens), set the ON times for each day of the week.
2. Set the OFF times for each day of the week.

Enable Schedule Function

The Schedule function is automatically enabled when values are entered in the Schedule screen. To disable a

scheduled event, navigate to the event and press . The event will appear gray on the screen when it is disabled. To re-enable an event, navigate to the event

and press . The event will appear red (system off) or green (system on). If no events are needed, turn the main power switch (H) OFF to prevent system from automatically enabling and disabling the heaters.

How to Use the Schedule Function

At the end of the work day leave main power switch (H)

ON . The Schedule function will automatically enable and disable the heaters and pump at the specified times.

Pressure Relief Procedure



Follow the Pressure Relief Procedure whenever you see this symbol.

This equipment stays pressurized until pressure is manually relieved. To help prevent serious injury from pressurized fluid, such as skin injection, splashing fluid and moving parts, follow the Pressure Relief Procedure when you stop spraying and before cleaning, checking, or servicing the equipment.

1. Turn main power switch (H) OFF .
2. Close the inlet air supply ball valve (AG).

Operation Tips to Maximize Adhesive Life

Set Pump Idle Time to System Inactive to the lowest value that will not interfere with normal operation (see **System Screen 2 – General Setup, page 86**). This feature will automatically disable the heating system after pump is idle for longer than the prescribed time. Disabling the heating system minimizes adhesive degradation.

Set melter, hose, and applicator to the same setpoint

Maintenance

Task	Maintenance Interval
Inspect Funnel Filter	6-12 months
Replace Pump Outlet Filter	50,000 lb (25,000 kg) of adhesive pumped
Replace Pump Inlet Filter	Rarely

Inspect Funnel and Filter



The funnel (81) and filter (77) should be inspected periodically to ensure air exhaust and flow of pellets into the melter is clear.

The filter (77) and upper portion of the funnel (81) can be inspected without interrupting production. Replace or clean the filter as needed. Use a flat blade screwdriver to remove stray glue or pellets or buildup.

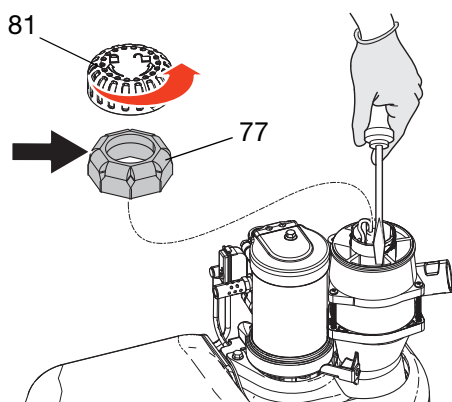

Infrequently, buildup in the lower portion of the funnel may need to be cleared. To do this, remove the three screws (72), separating the top of the funnel (79, 80) from the base (78). Use a flat blade screwdriver to remove built up adhesive.

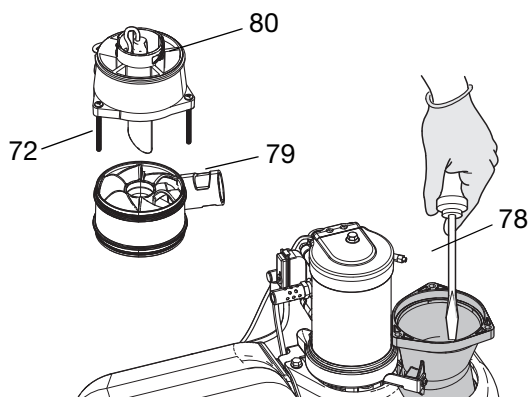

Replace Pump Outlet Filter



To avoid severe burns, wear protective gloves and clothing that will insulate your hands and body from the hot surfaces and material.

The pump outlet filter prevents small contaminants from entering hoses and applicators.

1. Warm system to operating temperature.
2. Perform **Pressure Relief Procedure** procedure, page 26, but replace the pump outlet filter before the system cools. Adhesive must be fluid to perform this procedure.
3. Verify that the main power switch (H) to OFF.
4. Use a 1 in. socket to unscrew outlet filter (TF).

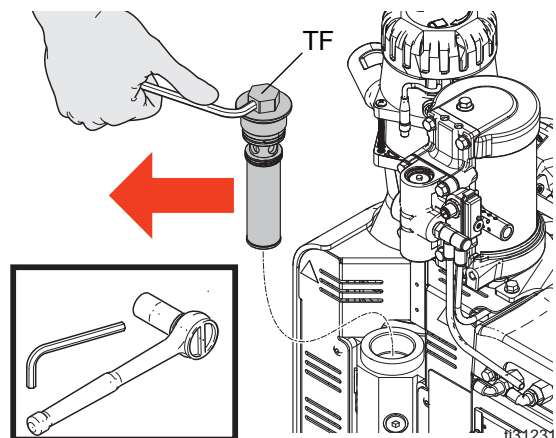

5. Insert an Allen wrench through the outlet filter cap to lift the outlet filter (TF) out.
6. Place o-rings (provided with new filter) onto new outlet filter (TF).
7. Place new outlet filter into melter housing and tighten with a 1 in. socket.

Replace Pump Inlet Filter

The inlet filter is designed to prevent large items from entering the systems.

			
<p>To avoid severe burns, wear protective gloves and clothing that will insulate your hands and body from the hot surfaces and material.</p>			

1. Increase temperature gradually until adhesive softens to a gel-like state.

2. Perform **Pressure Relief Procedure**, page 26.
3. Remove ADM and shrouding (331) from around the melter.
4. Remove the thermal insulation (651) from the melter.
5. Use a 9/16 in. socket to remove the inlet filter plug (FP).
6. Use o-ring pick or a small Allen wrench to remove filter screen (FS). Repeat step 2 if adhesive is not thin enough to remove.
7. Slide a new filter screen into melter manifold. Install filter plug (FP) using a 9/16 in. socket.

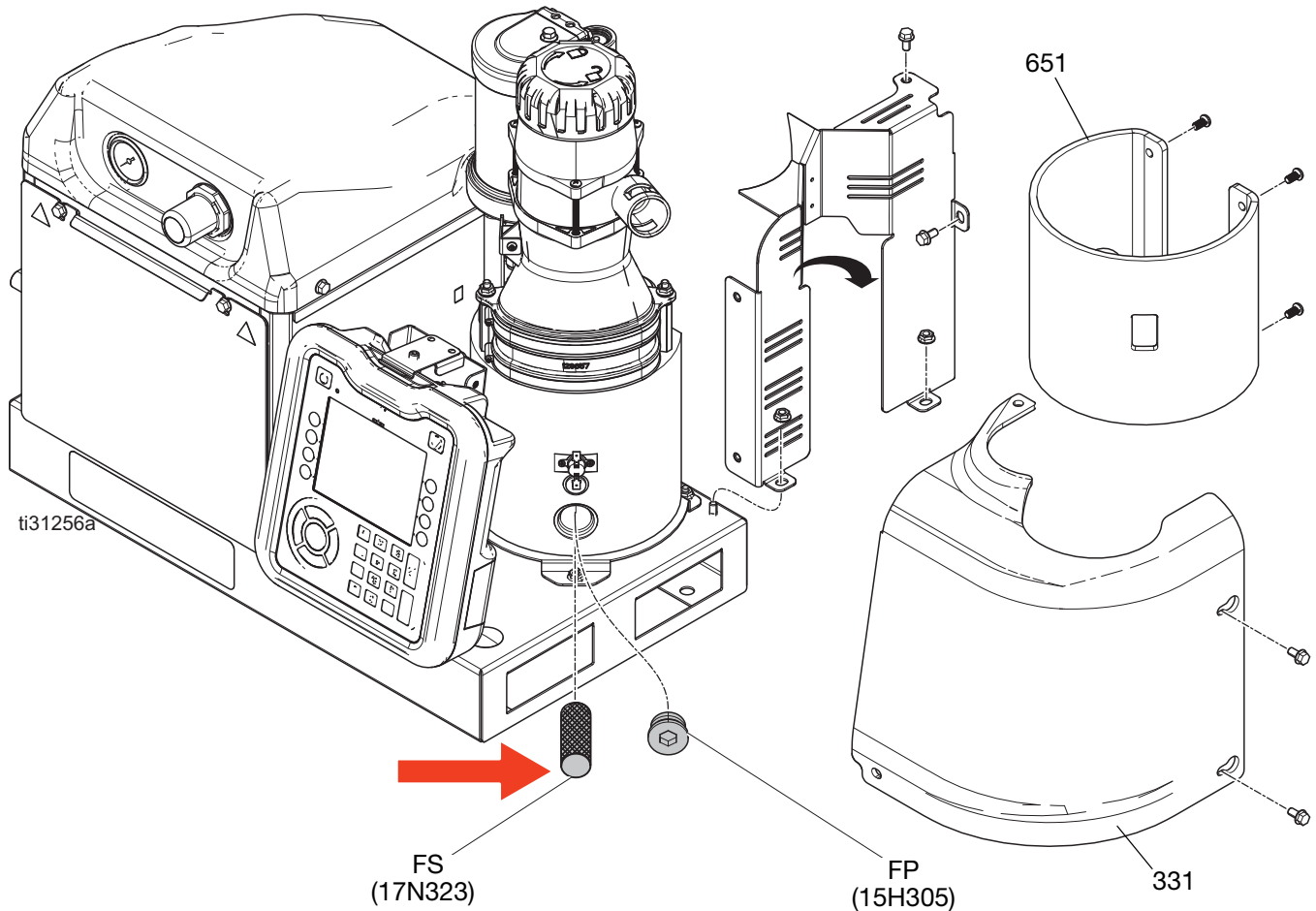

Drain System



NOTE: The system must be drained prior to flushing and prior to some maintenance and repair procedures.

1. Navigate to **System Screen 2 - General Setup** and select “Manual” from the “Refill Setting” dropdown menu (see **Appendix A - ADM (Advanced Display Module)** on page 80 for details).
2. If the system is inactive, press  to enable the heaters and pump.
3. Decrease pump air pressure (C) to 0.
4. Open system air inlet ball valve (AG).
5. Disconnect hose from applicator inlet then place hose outlet in a waste container. Repeat for all hoses. Keep hose to applicator electrical connector connected.
6. Open applicator to allow residual fluid in applicator to drain.
7. When system is at operating temperature, slowly increase pump air pressure (C) until fluid begins flowing into the waste container.

NOTE: It may take several minutes to empty the system. When there is no melter fluid at the pump, the pump will begin to cycle faster.

8. When the pump begins to cycle faster, close the system air inlet ball valve (AG).
9. Press  to disable the heaters and pump.
10. Remove melter drain plug (640).
11. Disconnect hose from melter outlet.
12. Wait until system stops draining or at most 10 minutes.

NOTE: There will be some residual adhesive in the system.

13. When done draining the system, navigate to **System Screen 2 - General Setup** and set Refill Setting back to “Auto” (see **Appendix A - ADM (Advanced Display Module)** on page 80 for details).

Flush

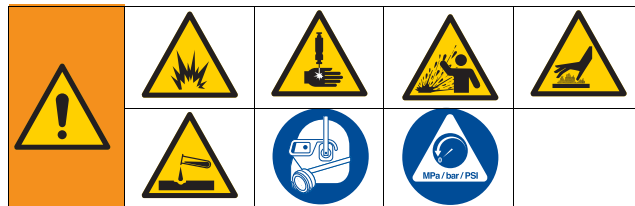



To prevent fire and explosion, use the adhesive manufacturer’s recommended cleaning fluid.

- Never exceed the cleaning fluid’s rated temperature.
- Never flush your system or clean any aluminum components with halogenated hydrocarbon cleaning solution.
- To prevent severe burns, wear protective clothing.

See the hot melt adhesive technical data sheet or SDS for the recommended cleaning fluid.

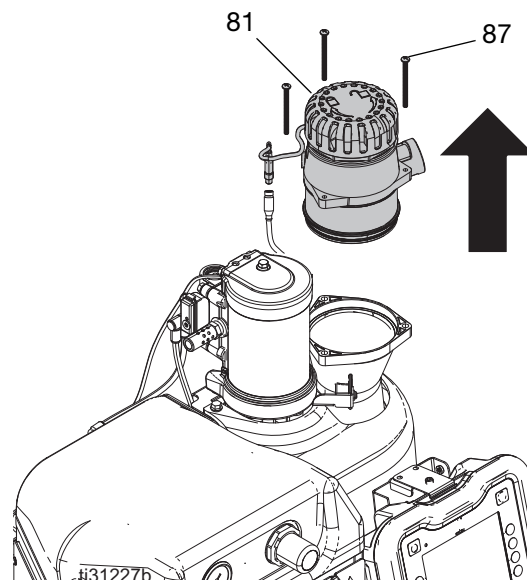
1. Perform **Pressure Relief Procedure**, page 26.
2. Perform **Drain the System** procedure, page 29.
3. Enter **Manual Refill** mode, page 24.
4. Remove the three bolts (87) shown below, then remove the top portion of the funnel (81).



				
To prevent fire and explosion, never exceed the cleaning fluid's rated temperature.				

5. Change temperature setpoints to the manufacturer's recommended temperature for the cleaning fluid. Allow all system zones to heat or cool to the recommended setpoint.
6. Verify the system air inlet ball valve (AG) is closed and pump air pressure is set to 0.
7. Fill melter with hot melt cleaning fluid. To avoid overfill and spilling, do not fill above the metal portion of the melter.
8. Allow hot melt cleaning fluid to soak in the melter for the duration specified by the cleaning fluid manufacturer.
9. Disconnect hose(s) from the applicator manifold(s) and route into a waste container.
10. Open air inlet ball valve (AG) and slowly increase pressure to purge into the waste container.
11. After flushing, set system back to **Automatic Refill** mode (see page 24). Then perform **Initial Startup and Prime** on page 23.

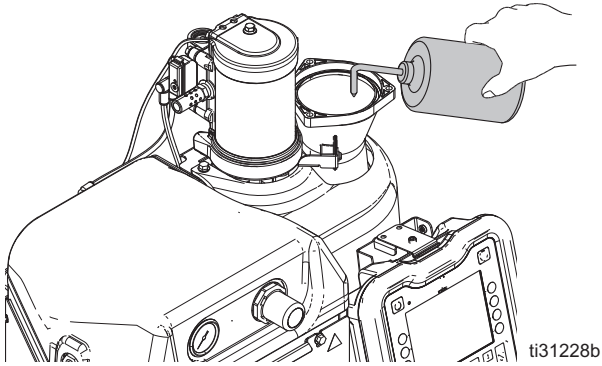

Troubleshooting

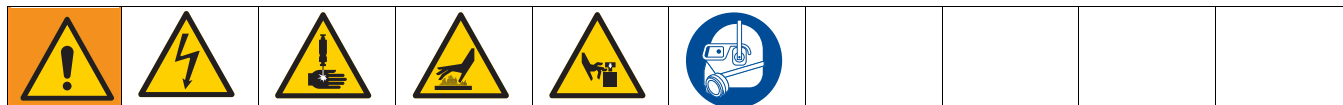

DANGER

SEVERE ELECTRIC SHOCK HAZARD



This equipment can be powered by more than 240V. Contact with this voltage will cause death or serious injury.

- Turn off and disconnect power at main switch before disconnecting any cables and before servicing equipment.
- All electrical wiring must be done by a qualified electrician and comply with all local codes and regulations.

To avoid injury due to unexpected machine operation initiated by a remote controller, disconnect the customer I/O cable from the system prior to troubleshooting.

NOTE: For the latest troubleshooting guidance, visit help.graco.com.

Error Codes

When an error occurs, press  to acknowledge the error. If a Maintenance error occurs, navigate to the Maintenance screen (see **Appendix A - ADM (Advanced Display Module)** on page 80) and press the reset counter softkey  to clear the error.

NOTE: Some of the error codes listed can apply to multiple items and contain a lookup letter (denoted by a bold letter in parentheses “()”). Use the following error code lookup tables to determine the specific source of an error.

InvisiPac System Error Code Lookup Tables

(Z)one	
1	Channel 1 Gun (Applicator)
2	Channel 1 Hose
3	Channel 2 Gun (Applicator)
4	Channel 2 Hose
5	Channel 3 Gun (Applicator)
6	Channel 3 Hose
7	Channel 4 Gun (Applicator)
8	Channel 4 Hose
9	Channel 5 Gun (Applicator)
A	Channel 5 Hose

(Z)one	
B	Channel 6 Gun (Applicator)
C	Channel 6 Hose
D	Channel 7 Gun (Applicator)
E	Channel 7 Hose
F	Channel 8 Gun (Applicator)
G	Channel 8 Hose

(M)odule	
1	AMZ 1
2	AMZ 2

InvisiPac Pattern Controller Error Code Lookup Tables

(G)un	
1	Pattern Control Gun 1 (Solenoid Valve)
2	Pattern Control Gun 2 (Solenoid Valve)
3	Pattern Control Gun 3 (Solenoid Valve)
4	Pattern Control Gun 4 (Solenoid Valve)
5	Pattern Control Gun 5 (Solenoid Valve)
6	Pattern Control Gun 6 (Solenoid Valve)
7	Pattern Control Gun 7 (Solenoid Valve)
8	Pattern Control Gun 8 (Solenoid Valve)

(L)ine	
1	Pattern Control Line 1
2	Pattern Control Line 2

Alarms (shuts system down)

Code	Description	Cause	Solution
A2D0	Low Current Melter (does not shut down system or melter zone)	Current through the melter heating rods is less than expected.	One or more of the fuses in the fuse harness assembly is blown. Remove short with corresponding melter heating rod and replace the fuse.
A40P*	High Current VPCM	Overcurrent on PCM circuit board accessory power supply output	Check accessory cabling for short circuit. Unplug one connection at a time.
A4(G)P*	High Current Gun (PCM)	Overcurrent on valve output	Check valve wiring for short circuit. Verify valve resistance is greater than 24 ohms.
A4D0	High Current Melter	Melter heater rods	Check resistance of melter heat rods. Check for excessively high system line voltage.
A4D(Z)	High Current Gun (AMZ)	Heater rods in gun manifold	Swap with known good gun. Refer to gun manual for nominal heater wire resistance. Check resistance and replace hose if necessary.
	High Current hose	Heater wires in hose	Swap with known good hose. Refer to hose manual for nominal heater wire resistance. Check resistance and replace hose if necessary.
A4FX	High current Fill Solenoid	Wiring shorted or fill solenoid drawing excessive current	Check for damaged wiring. Verify fill solenoid connection to J6-FILL of AMZ circuit board. Replace fill solenoid.
A4PX	High Current Pump Solenoid	Wiring shorted or pump solenoid drawing excessive current	Check for damaged wiring. Verify pump solenoid connection to J6-PUMP of AMZ circuit board. Verify solenoid resistance is 97 to 115 ohms. Replace pump solenoid.
A4SX	High Current 24 VDC Supply	Short in PLC I/O wiring	Unplug PLC I/O wiring from J8 of AMZ circuit board. Check resistance from power to ground.
		Short in Unit Counter wiring	Unplug unit counter from J10 of AMZ circuit board. Check resistance from power to ground. Verify solenoid resistance is 97 to 115 ohms.
		Short in Level Sensor wiring	Unplug level sensor from J4 of AMZ circuit board. Verify level sensor connection to J4 of AMZ circuit board.
A4XP	High Current VCAN	Overcurrent on communication cable output	Check CAN connection to P4 of PCM circuit board.
A7D0	Unexpected Current Melter	Unexpected current to melter	Check for damaged wiring. Check heater resistance to ground. Replace faulty heater(s). Replace AMZ circuit board.

Code	Description	Cause	Solution
A7D(Z)	Unexpected Current Gun	Unexpected Current to gun	Swap in known good gun. Swap in known good hose. Check heater resistance to ground. Replace AMZ circuit board.
	Unexpected Current Hose	Unexpected current to hose	Swap in known good hose. Check for damaged wiring. Check heater resistance to ground. Replace AMZ circuit board.
A8D0	No Current Melter	No current melter	Check J24 is plugged into AMZ. Check fuses FHA and FHB on AMZ.
A8D(Z)	No Current Gun	No current to gun	Swap in known good gun. Swap in known good hose. Check fuses on AMZ (F1 through F4). Check for damaged wiring. Check fro heater resistance.
	No Current Hose	No current to hose	Swap in known good hose. Check fuses on AMZ (F1 through F4). Check for damaged wiring. Check heater resistance.
CAC(M)	Comm. Error AMZ	System is unable to communicate with AMZ	Check dial positions. Set AMZ 1 to position "1" and AMZ 2 to position "2". Verify CAN cable is plugged in. Remove and reconnect, taking care not to cross-thread the connector nut. Verify solid green LED and blinking yellow LED on AMZ. Perform Software Update procedure on page 96.
CACP*	Comm. Error PCM	System is unable to communicate with PCM	Check dial position of PCM. Set to "0". Verify CAN cable is plugged in. Remove and reconnect, taking care not to cross-thread the connector nut. Verify solid green LED and blinking yellow LED on AMZ. Perform Software Update procedure on page 96.
CACX	Comm. Error SIOB (System I/O Board)	System is unable to communicate with SIOB	Verify solid green LED and blinking yellow LED on AMZ System I/O board.
DADX*	Pump Runaway	Melter ran out of adhesive	Refill feed bin. Reduce Adhesive flow rate. Verify adhesive temperature setting. See Fill System Verification on page 37.
		Worn or damaged pump seals.	Inspect pump seals. Replace if necessary.
K4(L)P	High Pulse Rate Line	Encoder pulse rate exceeds maximum limit	Select encoder with lower pulse rate. Reduce line speed or gearing ratio.
L6FX	Level Sensor Error	Level sensor is not reading within expected range	Check connection to level sensor. See Fill System Verification on page 37.
L8FX*	Refill Error	Adhesive refill timed out before completing	Refill feed bin and inspect for bridging or blocking. Check feed hose and wand for plugged material. Verify sufficient air supply and pressure. See Fill System Verification on page 37.

Code	Description	Cause	Solution
T4D0	High Temp. Melter	Melter temperature deviated above setpoint.	Check that RTD is fully seated in melter. Verify overtemperature switch connection to J1-OT of AMZ circuit board. Check continuity. Replace RTD if fully seated and temperature on screen is not stable.
T4D(Z)	High Temp. Gun	Gun temperature deviated above setpoint	Turn on system without dispensing. Check if hose maintains stable setpoint temperature. Check gun RTD. Swap with known good gun.
	High Temp. Hose	Hose temperature deviated above setpoint	Turn on system without dispensing. Check if hose maintains stable setpoint temperature. Verify melter temperature setting is not set above hose. Swap with known good hose.
T4MX	High Temp. Transformer	Transformer thermistor reading above 212° F (100° C)	Verify transformer fan is free of obstructions. Fan only spins when transformer is warm, and for a 5 second check each time electrical power is cycled.
T6D0	Sensor Error Melter	No reading from melter RTD	Verify RTD connection to J1-RTD1 on AMZ circuit board. Check RTD for continuity. Replace RTD.
T6D(Z)	Sensor Error Gun	No reading from gun RTD	Verify hose and gun connections. Swap with known good gun.
	Sensor Error Hose	No reading from hose RTD	Verify hose connection. Swap with known good hose.
T6MX	Sensor Error Transformer	No reading from transformer thermistor	Verify sensor connection to J2 on AMZ circuit board. Check wiring for damage.
T8D0	No Temp. Rise Melter	Melter temperature reading does not increase toward setpoint.	Check that RTD is installed in melter. Compare temperature displayed on screen vs temperature of melter. Replace RTD.
T8D(Z)	No Temp. Rise Gun	Applicator temperature reading does not increase toward setpoint.	Verify gun is not wet. Swap with known good gun. Check heater rod(s) in gun for proper resistance.
	No Temp. Rise Hose	Hose temperature reading does not increase toward setpoint.	Verify hose is not wet. Swap with known good hose.
V4M(M)	High Line Voltage AMZ	Refer to AMZ Input Power Verification section on page 37.	
V6M(M)	Invalid Power Type AMZ	Refer to AMZ Input Power Verification section on page 37.	

* Alarm turns off the pump, but system will remain at temperature.

Advisories and Deviations (does not shut the system down)

Problem	Description	Cause	Solution
A4MF	High Current Transformer Fan	Excessive current draw above 600mA	Check for pinched or shorted fan wiring. Replace fan.
A8FX	No Current Fill Solenoid	Refer to Fill System Verification section on page 37. Check for damaged wiring. Verify connection from fill solenoid to J6-FILL on AMZ circuit board. Verify solenoid resistance is 97 to 115 ohms.	
A8MF	No Current Transformer Fan	Fan is not connected or is blocked from spinning	Verify fan power cable is connected to J2 on AMZ circuit board. Verify fan is free of obstructions and can spin freely.
A8PX	No Current Pump Solenoid	Pump solenoid is connected to AMZ	Check for damaged wiring. Verify connection from pump solenoid to J6-PUMP on AMZ circuit board. Verify solenoid resistance is 97 to 115 ohms.
B2AX	Low Glue per Unit	Adhesive pressure is too low	Check if pump pressure has been reduced from desired level.
		Glue per until target needs to be reset	Navigate to material tracking page from home screen and press the gauge softkey to reset target setting.
		Gun module filter may be restricting flow	Replace gun module filter.
B3AX	High Glue per Unit	Adhesive pressure too high	Check if pump pressure as been increased from desired level.
		Glue per unit target needs to be reset	Navigate to material tracking page from home screen and press the gauge softkey to reset target setting.
		Nozzle size was increased	Check if desired nozzle size is installed.
DDDX	Pump Diving	Melter ran out of adhesive	Refill feed bin. Reduce adhesive flow rate. Verify adhesive temperature setting. See Fill System Verification on page 37.
		Worn or damaged pump seals	Inspect pump seals. Replace if necessary.
DE0X	Cycle Switch Error	No signal from cycle switch	Verify connection from cycle switch to J5 on AMZ. Replace cycle switch.
EVUX	USB Disabled	USB logging disabled	Enable USB logging. See Appendix A - ADM (Advanced Display Module) on page 80

Problem	Description	Cause	Solution
K1(L)P	Low Line Speed	Poor encoder coupling on line	Check to ensure proper coupling between line and encoder.
		Line speed is less than low line speed advisory level	Increase line speed or decrease low line speed advisory level.
L0FX	Manual Fill Mode	System is operating in manual fill mode	Change to auto fill mode in System Setup screen 2.
L3FX	Slow Refill	Refills are taking longer than expected and may soon result in failure to fill	See Fill System Verification on page 37.
MMUX	USB Logs Full	USB logs full - data loss will occur if data is no downloaded	Download USB data. See Appendix B - USB Downloading, Uploading on page 93.
MND(X)	Pump maintenance due	Pump maintenance is due according to the user-defined settings for pump cycles, material dispensed, or time while hot.	Perform maintenance and reset “Due” counter to 0 at the Setup Maintenance screen.
T2D(Z)	Low Temp Gun	Gun deviated below setpoint.	Turn on system without dispensing. Check if gun maintains stable setpoint temperature. Check gun RTD. Swap with a known properly functioning gun.
	Low Temp Hose	Hose deviated below setpoint.	Turn on system without dispensing. Verify melter temperature setting is not higher than hose setting. Check if hose maintains stable setpoint temperature. Swap with a known properly functioning hose.
	Low Temp Melter	Melter deviated below setpoint.	Check that RTD is fully seated in melter. Replace RTD if fully seated and temperature on screen is not stable.
V20P	Low Voltage VPCM	PCM supply voltage below 18 VDC	Check connection and supplied voltage to P1 of PCM circuit board.
V30P	High Voltage VPCM	PCM supply voltage above 28 VDC	Check connection and supplied voltage to P1 of PCM circuit board.
V2M(M)	Low Line Voltage AMZ	Refer to verification section AMZ Input Power Verification section on page 37.	
V2XP	Low Voltage 24 VDC PCM	System power supply voltage below 18 VDC	Check power supply voltage to J3 of AMZ circuit board.
V3XP	High Voltage 24 VDC PCM	System power supply voltage above 28 VDC	Check power supply voltage to J3 of AMZ circuit board

Fill System Verification

1. Check air filter by removing quick turn cap on top of funnel. Clean or replace if needed.
2. Remove top section of funnel and inspect. Remove stuck debris if needed. Ensure level sensor sight tube is clear of debris.
3. Verify air supply to system is strong and between 50 and 100 psi (80 to 100 psi preferred).
4. Verify level sensor readings on diagnostic screen are consistent and slowly increase as material is dispensed.
5. Inspect air line and vacuum tubing to feed bin. Dips or kinks in the vacuum tubing can lead to a blocked flow path.
6. Check number of pump cycles in between refills (8 to 10 cycles is desired). Short fills of 3 or fewer cycles can be caused by clogged funnel filter or debris in funnel.
7. Monitor pellet flow and time to refill. Refills in excess of 15 seconds can be caused by low adhesive level in feed bin, insufficient air pressure, restricted feed hose, or clogged funnel filter.
8. Verify size and shape of adhesive being fed is compatible with feed system and that melt rate ability is not exceeded.
9. Check if glue is excessively dusty or releases oily vapor when heated. Fill system maintenance will be minimal given typical glue selection.

Input Power Verification

1. Verify that the wires are tightly secured into the electrical disconnect.
2. Confirm wiring matches label on electrical disconnect.

3. Measure incoming line voltage. For a transformer system, also measure transformer output voltage at the terminal block.
4. Verify power connections to J22 on the AMZ circuit board are fully seated.
5. Check internal wiring against **Electrical Schematics**, starting on page 52.

Melter Pump and Fluid Hose Leak Troubleshooting

1. **Drain System** follow instructions on page 29.
 2. Disconnect the hose from the fluid port connector and electrical port connector. Then disconnect the fluid port connector from the melter pump.
 3. Inspect the fluid port connector seal for damage. If damaged, then replace the port connector. Replacement components are available in **Fluid Port Connectors Kit 24V504**. See page 72 for kit details.
- NOTE:** Fluid hose leaks are often caused by damaged port connector seals. For persistent leaks, replace the fluid port connector.
4. Install the port connector onto the melter pump. Torque the fluid port connector to 180 in-lb (20 N•m).
 5. Use two wrenches to install the heated fluid hose onto the port connector. Torque the hose to 300 in-lb (33 N•m).

NOTICE

Over-tightening the hose port connector will damage the connector seal and cause fluid leaks. Do not over-tighten the port connector. Use two wrenches to torque the hose to the melter pump.

Hose Torque Instructions

- 1 Torque the port connector to 180 in-lb (20 N•m)
- 2 Hose-to-connector: Torque to 300 in-lb (33 N•M). Always use two wrenches.

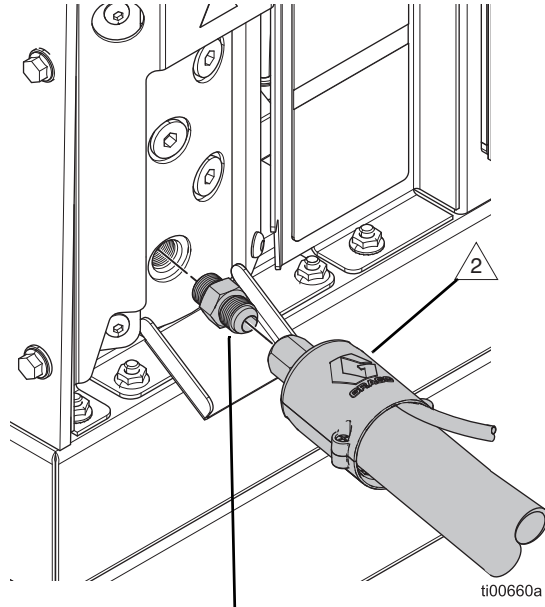
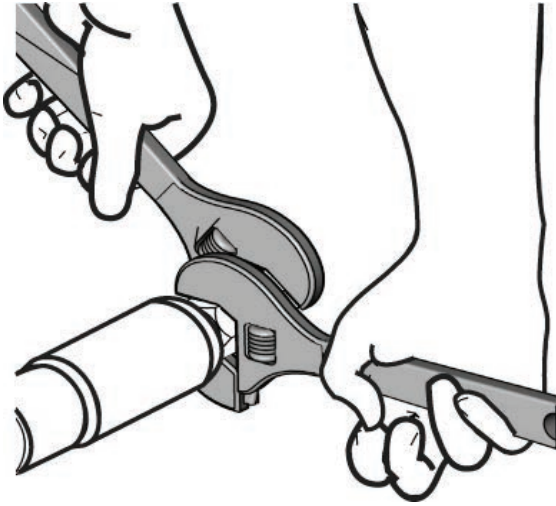

1 Fluid Port Connector Options

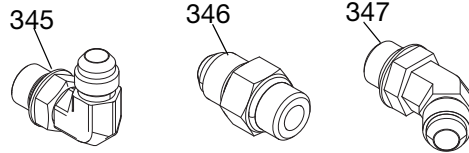

3A4938_kit_24V504

FIG. 3

Repair

NOTE: Some procedures require special tools. Read through each procedure prior to beginning it to ensure that you have the required tools to complete the entire procedure.

When performing any procedure that requires removal of seals or other soft parts, do not leave a system that has not been flushed disassembled for more than 30 minutes to prevent the adhesive from hardening. Hardened adhesive will damage the seals and other soft parts during installation.

System



Replace the Level Sensor

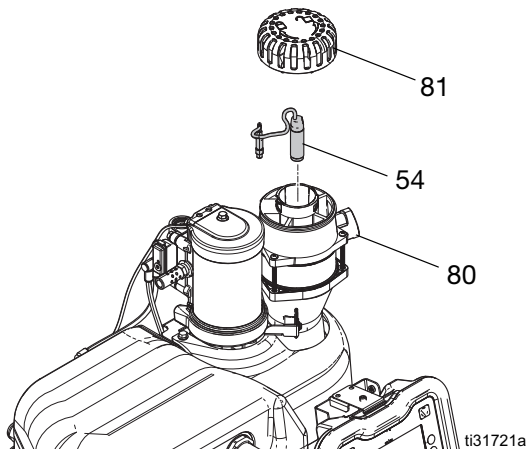

1. Turn the main power switch (H) OFF.
2. Remove the funnel filter cap (81) and filter element.



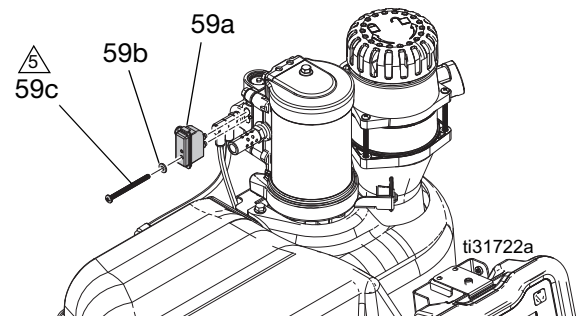

3. Disconnect the cable on the level sensor (54) from the machine and pull the cable through the top of the HM25c sensor housing (80).
4. Unscrew the level sensor (54) and remove it from the HM25c sensor housing (80).
5. Thread the new level sensor (54) into the HM25c sensor housing (80).
6. Reconnect the level sensor cable, filter and funnel filter cap (81).

Replace the Cycle Switch

1. Turn the main power switch OFF.
2. Disconnect the cable from the cycle switch (59a).
3. Use a screwdriver to remove screw (59c).
4. Remove cycle switch (59a) from the motor.
5. Replace new cycle switch and tighten screw (59c). Torque to 7-10 in-lb (0.7-1.0 N•m).
6. Reconnect the cycle switch cable.



Air Controls

			
DANGER			
SEVERE ELECTRIC SHOCK HAZARD			
This equipment can be powered by more than 240V. Contact with this voltage will cause death or serious injury.			
<ul style="list-style-type: none"> Turn off and disconnect power at main switch before disconnecting any cables and before servicing equipment. 			

Replace the Air Control Solenoid and Pump Regulator

1. Perform the **Pressure Relief Procedure**, page 26.
2. Close the bleed-type ball valve installed at the system air inlet to relieve all air pressure in the system.
3. Use a 3/8 in. socket to remove six screws (336) from the air control panel cover and electrical enclosure front access panel.
4. Remove the air control cover (330) to access the air control panel. Remove the electrical enclosure front access panel (EFP) (only required if replacing the solenoid).

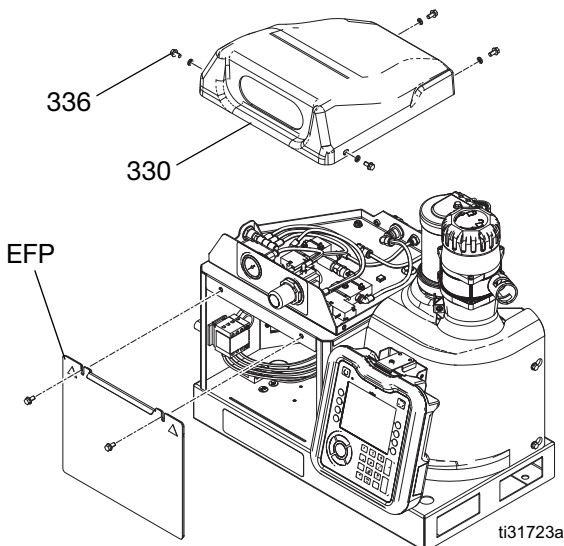

5. Replace the Pump Air Regulator and Gauge:
 - a. Disconnect the air tubing from regulator (502) and remove panel nut (524).
 - b. Remove the regulator from the panel.



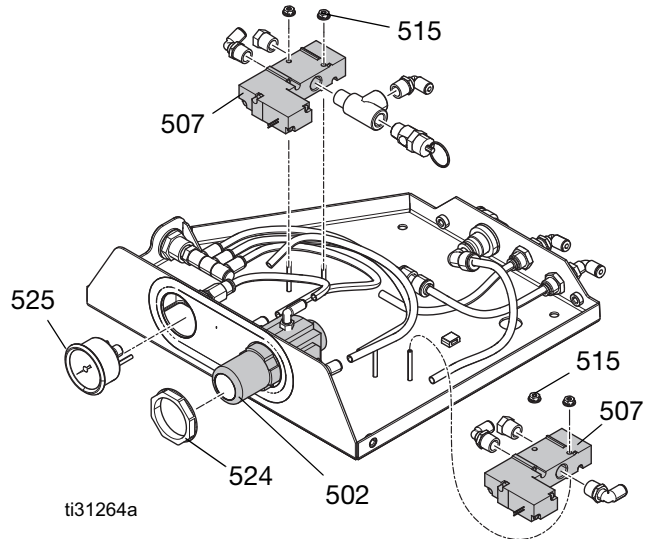

- c. To install a new regulator, perform steps 1 and 2 in reverse.

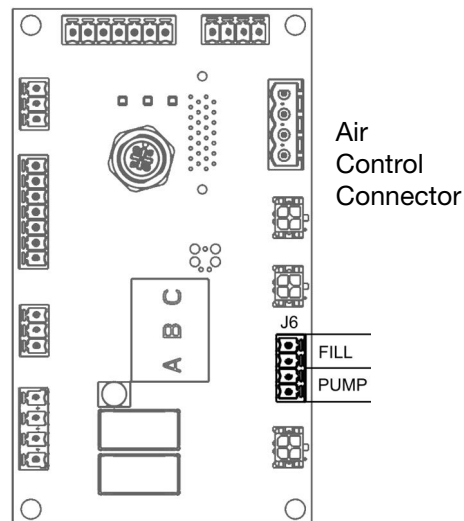

6. Replace the Solenoid:
 - a. Disconnect the air tubing from the solenoid (507) to be replaced.
 - b. Inside the electrical enclosure, disconnect the air control electrical connector from the AMZ daughter board and remove the leads for the solenoid to be replaced.
 - c. Use a 5/16 in. socket to remove two nuts (515) and remove solenoid (507).
 - d. Pull the solenoid leads out through the grommet in the top of the air control panel.
 - e. To install the new solenoid, perform steps 1 through 4 in reverse.



Melter

				
<p>DANGER SEVERE ELECTRIC SHOCK HAZARD This equipment can be powered by more than 240V. Contact with this voltage will cause death or serious injury.</p> <ul style="list-style-type: none"> Turn off and disconnect power at main switch before disconnecting any cables and before servicing equipment. <p>BURN HAZARD Equipment surfaces and fluid that is heated can become very hot during operation. To avoid severe burns, wear protective equipment and do not touch hot fluid or equipment.</p>				

Replace the Temperature Sensor

1. Turn the main power switch OFF.
2. Remove the electrical enclosure door (332) and remove the melter control connector from AMZ #1 daughter board.

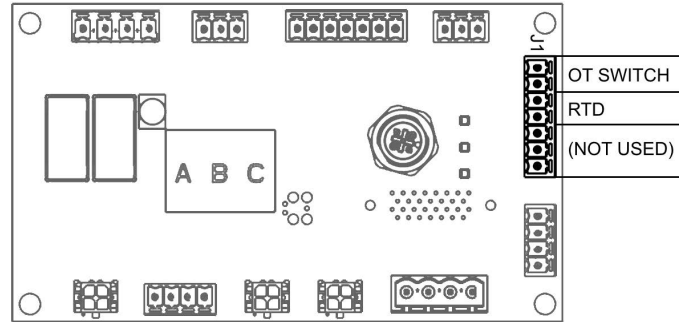

3. Remove the temperature sensor (RTD) leads from the connector as shown. See **Electrical Schematics** on page 52.
4. Use a 3/8 in. socket to remove four screws (336) from melter shroud (331) and remove shroud.
5. Remove screw (RS) retaining the temperature sensor (RTD) and remove the sensor from the melter manifold.
6. Pull the leads through grommet (13) in the side of the electrical enclosure.
7. Replace the new temperature sensor (RTD) and thread in retaining screw (RS). Torque to 7-10 in-lb (0.7-1.0 N•m).
8. Insert sensor leads into the side of the electrical enclosure through grommet (13).
9. Tighten the temperature sensor leads into the connector as shown. Reconnect the connector back into AMZ #1. See **Electrical Schematics** on page 52.

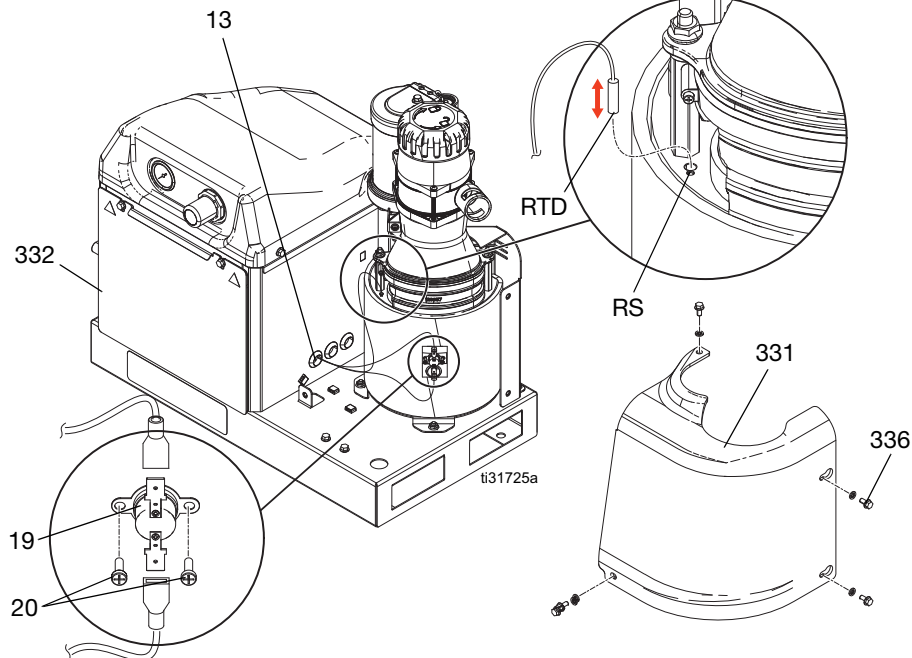

Replace the Overtemperature Switch

1. Turn the main power switch (H) OFF.
2. Use a 3/8 in. socket to remove four screws (336) from melter shroud (331), then remove the shroud.
3. Remove the spade connectors from the over-temperature switch (20).
4. Use a screwdriver to remove two screws (19) retaining the over-temperature switch (20).
5. Replace the spade connectors from the over-temperature switch cable onto the new switch (20).
6. Replace the over-temperature switch (20) and retaining screws (19). Torque to 7-10 in-lb (0.7-1.0 N•m).
7. Replace melter shroud (331) and screws (336).

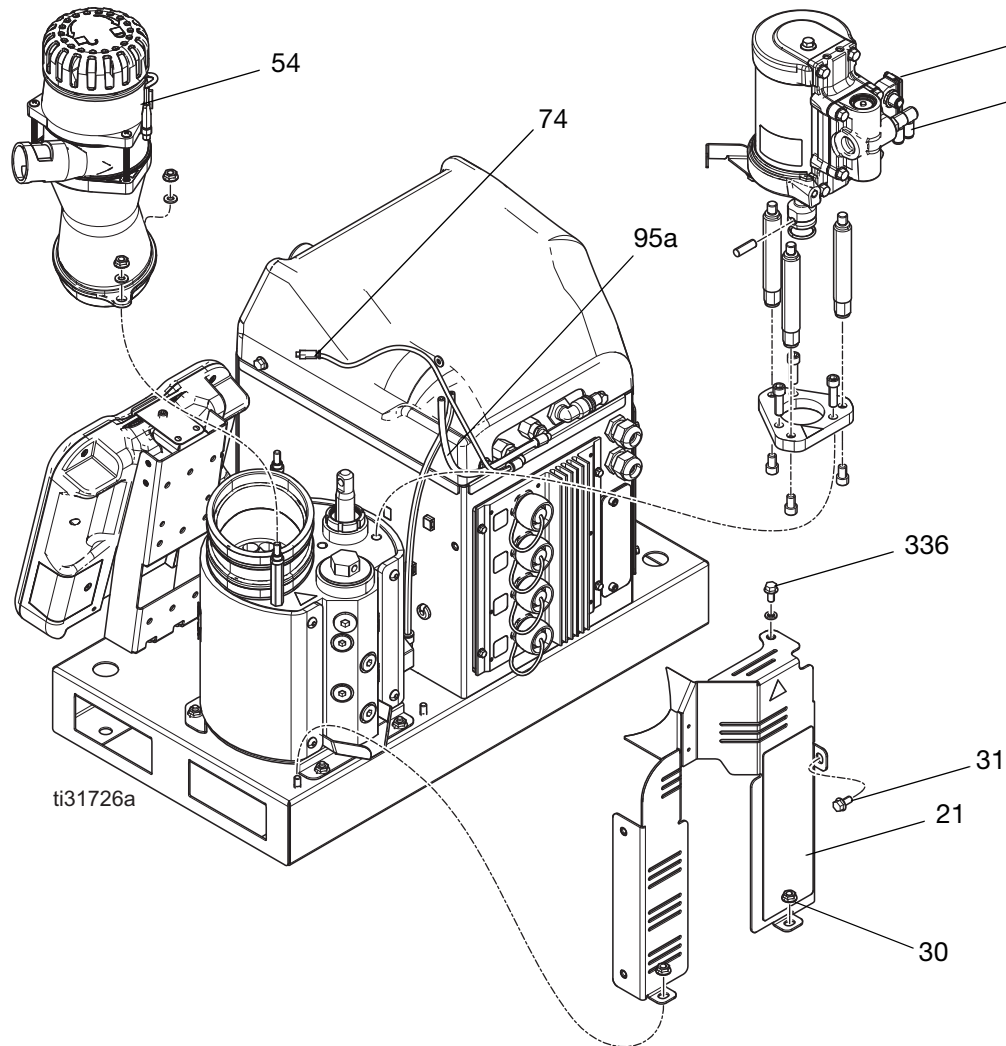

Remove the Melter from the System



1. Perform the **Pressure Relief Procedure**, page 26.
2. Use a 3/8 in. socket to remove four screws (336) from the melter shroud (331), then remove the shroud.
3. Use a 7/16 socket to remove two nuts (30) and a 3/8 in. socket to remove screw (31) from the melter rear cover (21).
4. Disconnect the pump supply air tube (95a) from the air motor air inlet fitting (659).
5. Disconnect the cycle switch cable from cycle switch (59).
6. Disconnect the level sensor cable from level sensor (54).

- Disconnect the level sensor cooling air tube from 5/32 in. push-to-connect fitting (74).

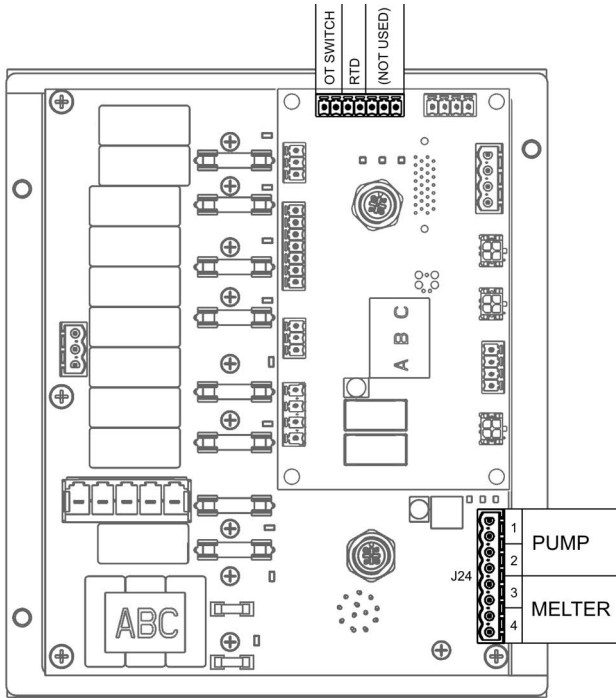

- Remove the electrical enclosure door (332) and remove the melter control connector from AMZ #1 daughter board.
- Remove the temperature sensor (RTD) and over-temperature switch leads from the connector as shown. See **Electrical Schematics** on page 52.
- Remove the melter and pump heater connector from AMZ #1 as shown.
- Remove the melt heater leads from the connector. See **Electrical Schematics** on page 52.

- Pull the temperature sensor, over-temperature switch, and heater leads through grommet (13) in the side of the electrical enclosure.
- Use a 7/16 in. socket to remove four nuts (30) from the melter base plate.
- Grasp the air motor to lift and rotate the melter assembly off from the system base.

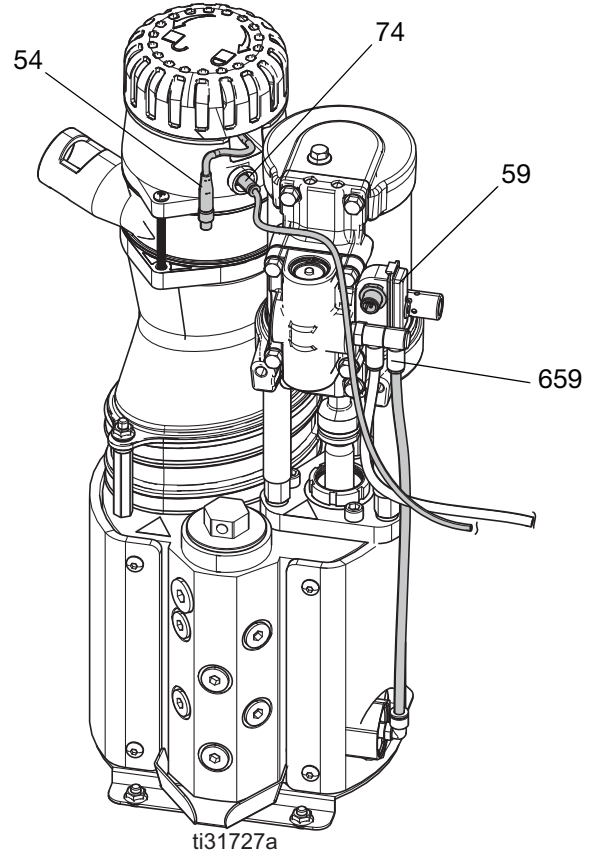

Reassemble the Melter Onto the System



1. Perform the **Pressure Relief Procedure**, page 26.
2. Locate the melter on the system base and fasten four nuts (30). See **Parts** on page 58.
3. Insert the temperature sensor, over-temperature switch, and heater leads through grommet (13) in the side of the electrical enclosure.
4. Reconnect the temperature sensor (RTD), over-temperature switch (OT), and heater leads into the connectors for AMZ #1 as shown. See **Electrical Schematics** on page 52.
5. Replace electrical enclosure door (332).
6. Reconnect the level sensor cooling air tube from 5/32 in. push-to-connect fitting (74).
7. Reconnect the cable from the enclosure to the level sensor (54).
8. Reconnect the cable from the enclosure to the cycle switch (59).
9. Reconnect pump supply air tube (95a) to the air motor air inlet fitting (659).
10. Fasten melter rear cover (21) with two nuts (30) and screw (31).
11. Reattach melter shroud (331) with four screws (336).

Item	Heater Rod Wire Marking	AMZ Connector Marking
Pump Heater Rod 1	J24-1 (2 wires)	J24-1 (2 terminals)
Pump Heater Rod 2	J24-2 (2 wires)	J24-2 (2 terminals)
Melter Heater Rod 1	J24-3 (2 wires)	J24-3 (2 terminals)
Melter Heater Rod 2	J24-4 (2 wires)	J24-4 (2 terminals)

Pump



Replace the Fluid Pressure Relief Valve

1. **Flush** the system, see page 29.
2. Perform the **Pressure Relief Procedure**, page 26.
3. Remove the melter shroud and rear cover. Follow steps 1-9 of **Remove the Air Motor**, page 46.

When performing any procedure that requires removal of seals or other soft parts, do not leave a system that has not been flushed disassembled for more than 30 minutes to prevent the adhesive from hardening. Hardened adhesive will damage the seals and other soft parts during installation.

4. Use a 7/16 socket to remove four nuts (30) from the melter base plate. Rotate the melter to gain clear access to the pressure relief valve.
5. Disconnect air tube (95b) leading from the air motor inlet fitting to the pressure relief valve (642).

6. Use a 5/32 Allen wrench to remove the two insulation fasteners (652) closest to the relief valve.
7. Roll the meter insulation (651) back past the relief valve. This will prevent fluid from soaking it during repair.
8. Place a rag or cloth between the melter and melter base plate beneath the relief valve to catch any fluid.
9. Use a 1-7/16 in. socket or box wrench to remove relief valve (642) from the melter.
10. Replace the pressure relief valve and wipe away any fluid from the side of the melter.
11. Roll the melter insulation (651) back around the melter and secure with insulation fasteners (652).
12. Reconnect air tube (95b) to relief valve and air motor inlet fitting.
13. Rotate the melter back into place on mounting studs. Secure the melter base plate with nuts (30).
14. Replace the melter rear cover and shroud.

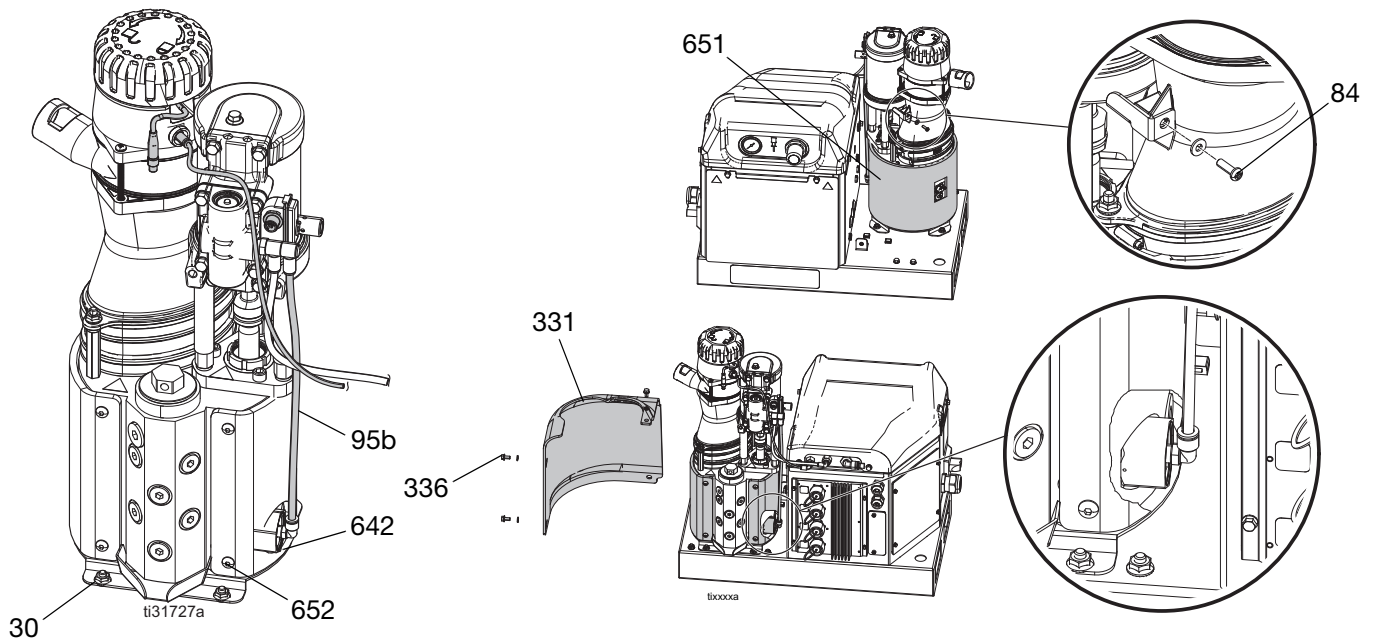

Remove the Air Motor

1. Perform the **Pressure Relief Procedure**, page 26.
2. Use a 3/8 in. socket to remove four screws (336) from melter shroud (331), then remove the shroud.
3. Use a screwdriver to remove screw (84) from the funnel motor support bracket. This will allow removal of the funnel from the melter.
4. Use a 7/16 in. socket to remove two nuts (30) and a 3/8 in. socket to remove screw (31) from the melter rear cover (21).
5. Use a 7/16 in. socket to remove two nuts (30) from the funnel standoffs and remove funnel from the melter.
6. Disconnect air tubes (95a, 95b) from the air motor air inlet fitting (659).
7. Slide retaining ring (604) up the shaft of the air motor and slide pump connecting pin (603) from the motor and pump shafts.
8. Use a 1/4 Allen wrench to remove three screws (605) from the air motor mounting plate (606) and lift air motor (601) off of the melter.

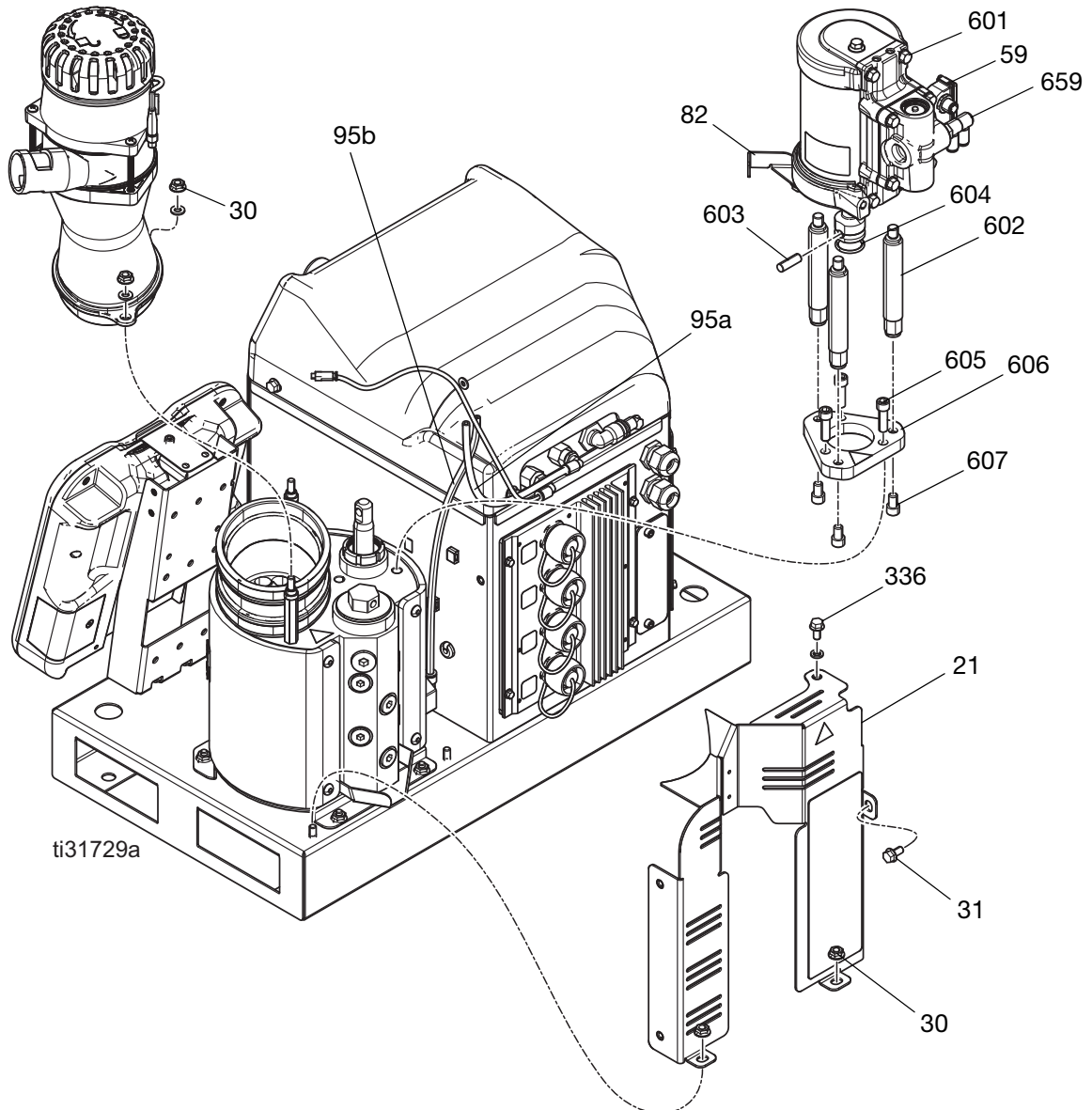

Replace the Air Motor

1. Use a 1/4 in. Allen wrench to remove three screws (607) from the bottom of the air motor mounting plate (606), then remove the mounting plate.
2. Remove tie rods (602) from air motor (601).
3. Use a 13 mm socket to remove screw (83) holding the funnel motor support bracket (82) from the air motor.
4. Remove cycle switch (59). Perform **Remove the Cycle Switch** procedure, page 39.
5. Slide retaining o-ring (604) off of old motor shaft and onto new air motor.
6. Reinstall cycle switch (59) and the funnel motor support bracket (82) on the new air motor.
7. Reinstall tie rods (602) into the motor mounting plate (606) and tighten screws (607).
8. Place the air motor back onto the melter.
9. Slide pump connecting pin (603) through the motor and pump shaft. The motor shaft may need to be manually raised, lowered, or rotated to the correct position.
10. Slide retaining o-ring (604) into place over the connecting pin.
11. Reinstall screws (605) to secure the air motor onto the melter.
12. Replace the funnel assembly, melter rear panel, and melter shroud.

Remove the Pump Rod, Throat Seal, and Bearing

1. Perform the **Flush** procedure on page 29.
2. Perform **Remove the Air Motor** on page 46.
3. Use a screwdriver and rubber mallet to break loose retaining nut (608).
4. Remove retaining nut (608) from the pump throat.
5. Insert an Allen wrench through the hole in the top of piston rod (PR) to lift the pump rod assembly, throat seal, and bearing out of the pump.

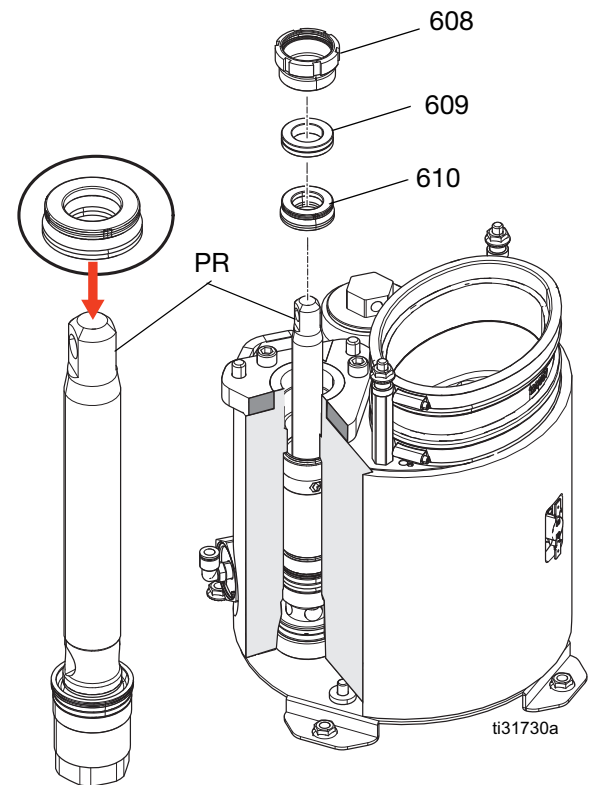

Replace the Pump Rod, Throat Seal, and Bearing

1. To protect seals from threads, place seal installation tool 15B661 into the throat bore.
2. Push the piston rod assembly (PR) into the pump.
3. Grease throat seal (610) and slide over the piston rod with the lips facing down.
4. Place a 7/8 in. deep-well socket (3/8 in. drive) over the piston rod and use a rubber mallet to gently tap throat seal (610) into place.
5. Slide throat bearing (609) over piston rod. Use a socket and mallet to press the throat bearing into place.
6. Remove the seal installation tool 15B661.
7. Install retaining nut (608).
8. To reassemble the air motor onto the pump. See **Replace the Air Motor** on page 47.

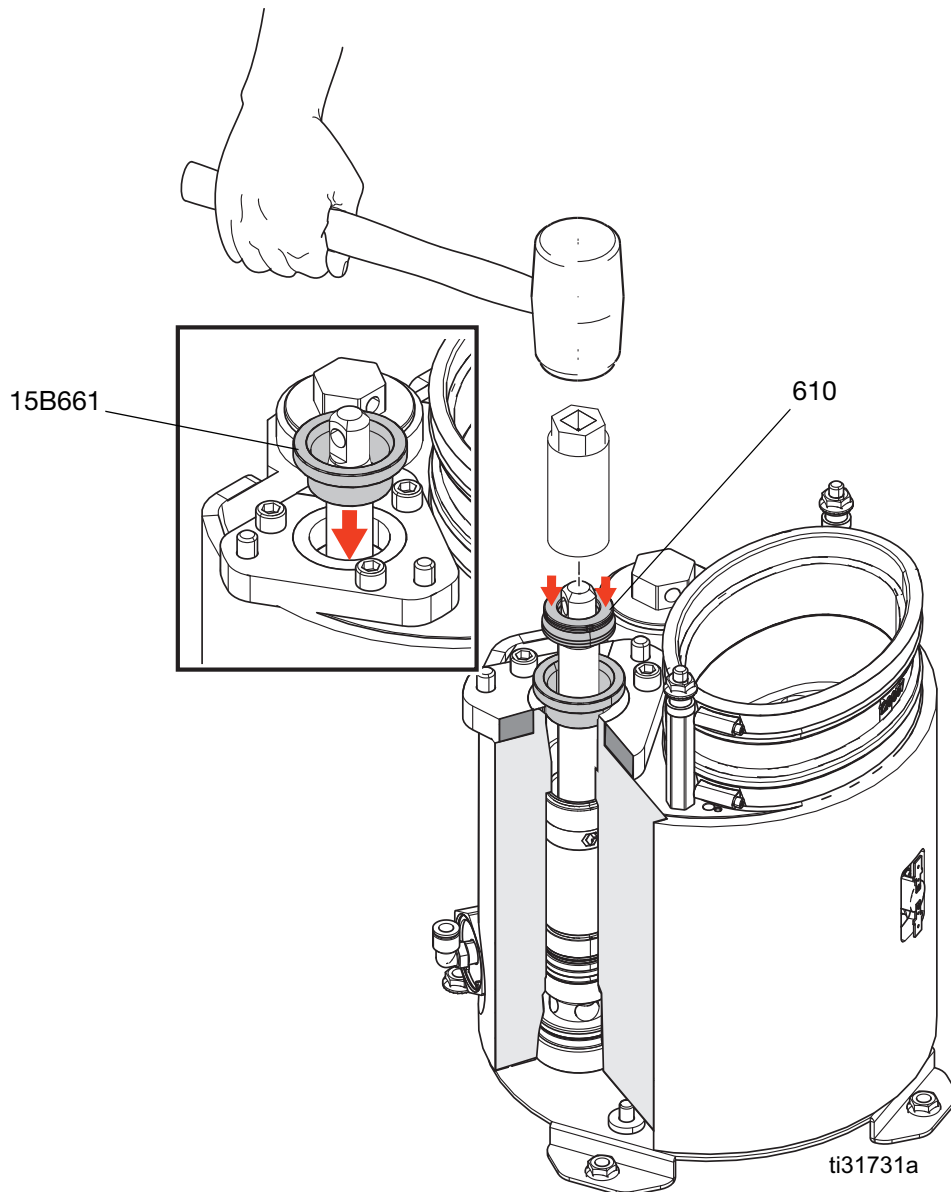

Replace the Pump Inlet Housing Check and Cylinder Seals



Replace the Pump Inlet Housing Check

1. **Flush** the system, see page 29.
2. Perform the **Pressure Relief Procedure** on page 26.
3. Remove the melter by following the **Remove the Melter from the System** procedure on page 42.

When performing any procedure that requires removal of seals or other soft parts, do not leave a system that has not been flushed disassembled for more than 30 minutes to prevent the adhesive from hardening. Hardened adhesive will damage the seals and other soft parts during installation.

4. Turn the melter onto its side. **NOTE:** Do not rest the melter on its over-temperature switch.
5. Use a 3/8 in. socket to remove four screws (627) and lift the melter base plate from the melter. Retain thermal insulators (628) for reassembly.

6. Use a 1/2 in. square-drive ratchet (without socket) to remove pump inlet housing (625) from the melter.
7. Remove and discard inlet seat (622) and o-ring (623) and inlet check ball (621).
8. Install new o-rings (626) and (624) onto the inlet housing.
9. Install new o-ring (623) in the housing underneath new seat (622) and ball (621).
10. Remove and discard inlet housing o-rings (626, 624).
11. Apply grease to all seals before reassembling.
12. Reinstall the new pump inlet housing and checks.
13. Apply a small amount of grease to insulators (628) and place into holes in the melter base plate. The grease will hold them in place during assembly. Take care not to grease the heater leads.
14. Line up the melter base plate and tighten screws (627).
15. Reassemble the melter onto the system by following the **Reassemble the Melter Onto the System** on page 44.

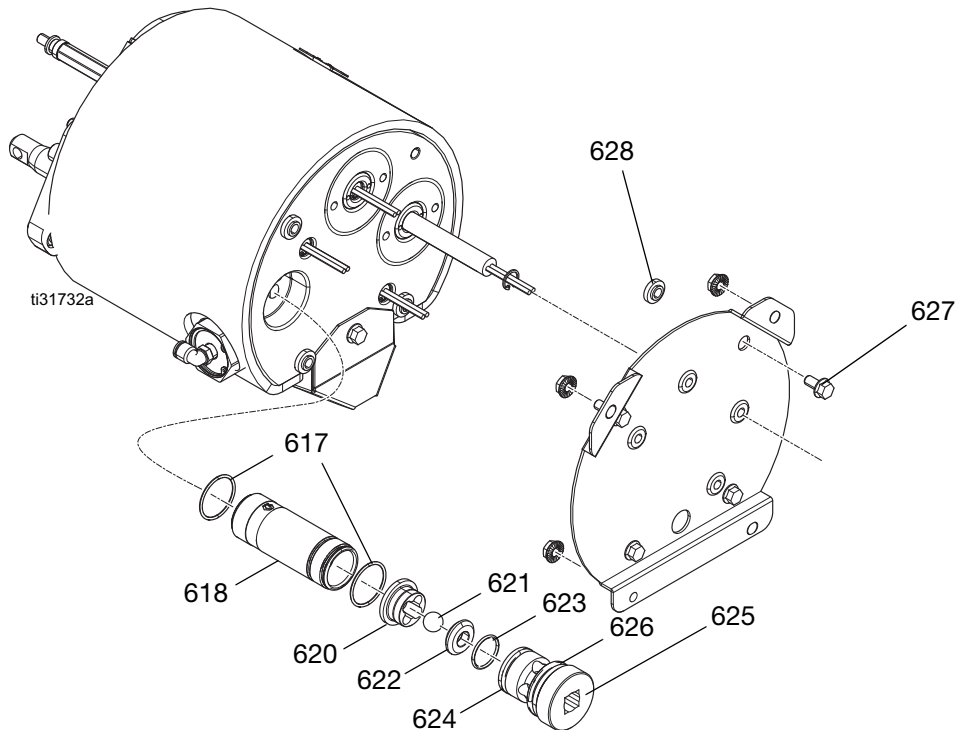

Replace the Pump Cylinder Seals

1. Perform **Flush** procedure on page 29.
2. Perform the **Pressure Relief Procedure**, page 26.
3. Perform the **Remove the Melter from the System** procedure on page 42.
4. Remove the pump rod (see on page 47).
5. Insert the cylinder removal tool (1301) into the pump throat.
6. Gently tap the cylinder removal tool with a rubber mallet to remove cylinder (618). Discard o-rings (617).
7. Install new o-rings (617) onto cylinder and apply grease.
8. Place the cylinder female installation tool (1302) into the pump inlet bore to protect the seals.
9. Use the male installation tool (1303) to gently press the cylinder into the melter.
10. Reinstall the pump inlet housing following steps 11-16 of the **Replace the Pump Inlet Housing Check** procedure on page 49.

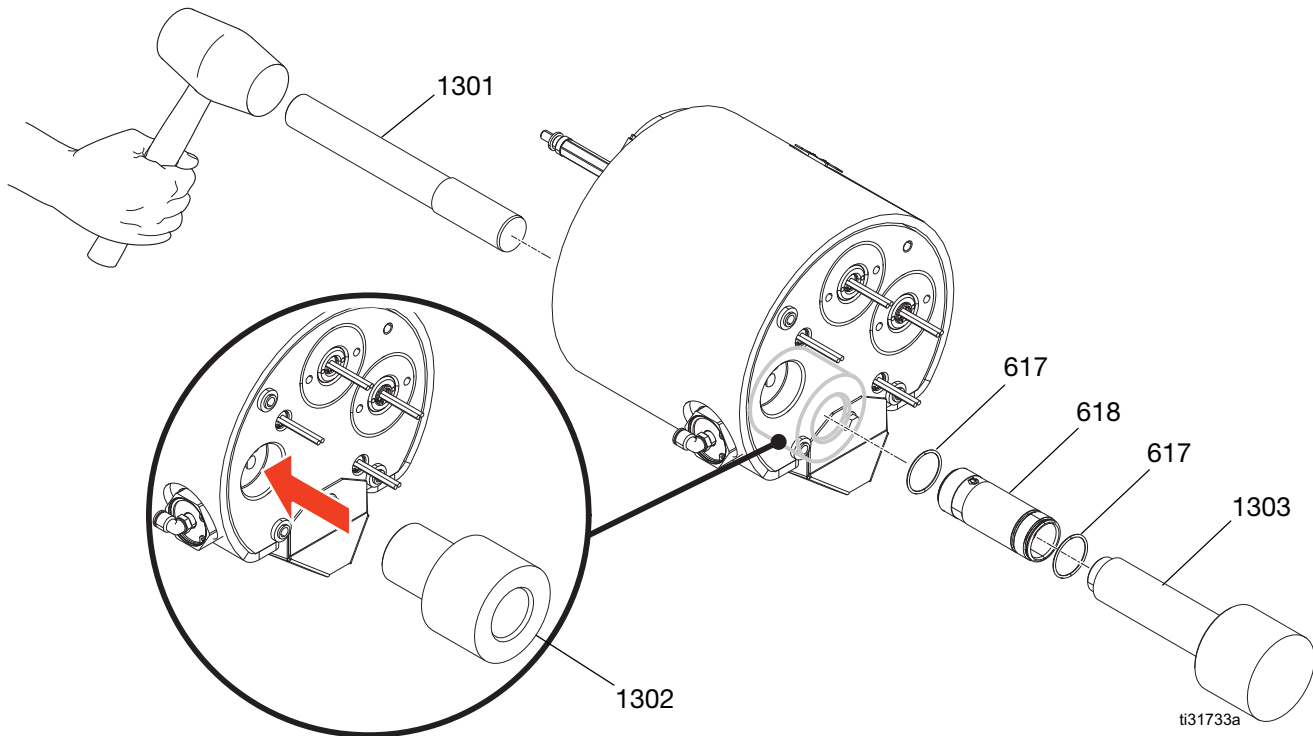

Heaters

Replace the Melter and Pump Heaters



DANGER

SEVERE ELECTRIC SHOCK HAZARD

This equipment can be powered by more than 240V. Contact with this voltage will cause death or serious injury.

- Turn off and disconnect power at main switch before disconnecting any cables and before servicing equipment.

1. Perform the **Pressure Relief Procedure**, page 26.
2. Use a 3/8 in. socket to remove four screws (336) from melter shroud (331), then remove the shroud.
3. Perform the **Remove the Melter from the System** procedure on page 42.
4. Verify the resistance of the heater. Each heater should have a resistance of **52-64** ohms.

NOTE: The heater connector must be removed from AMZ #1 when verifying resistance. If checking resistance with the connector plugged in, the heaters should have a parallel resistance value of **26-32** ohms.

5. If the heater needs to be replaced, follow steps 6-8, otherwise proceed to step 9. Repair kit 17P347 includes four heaters with identification labels attached.
6. Turn the melter onto its side. **NOTE:** Do not rest the melter on its over-temperature switch.

7. Use a 3/8 in. socket to remove four screws (627) and lift the melter base plate from the melter. Retain the thermal insulators (628) for reassembly.
8. Remove retaining rings (631) and slide the heater (632) out of the housing bore. **NOTE:** The heater may become seized into the housing due to thermal cycling. The heater may be removed more easily with the system at a safe warm temperature below the melting point of the glue. If removal is not possible, melter manifold kit 17S258 includes the two pump heaters pre-installed.
9. After installing the new heater rod(s), replace retaining ring(s) (631) and thread the leads through grommets (639) in the melter base plate.
10. Apply a small amount of grease to insulators (628) and place into holes in the melter base plate. The grease will hold them in place during assembly. Do NOT grease the heater leads.
11. Line up the melter base plate and tighten screws (627).
12. Perform the **Reassemble the Melter onto the System** procedure on page 44.

Item	Heater Rod Wire Marking	AMZ Connector Marking
Pump Heater Rod 1	J24-1 (2 wires)	J24-1 (2 terminals)
Pump Heater Rod 2	J24-2 (2 wires)	J24-2 (2 terminals)
Melter Heater Rod 1	J24-3 (2 wires)	J24-3 (2 terminals)
Melter Heater Rod 2	J24-4 (2 wires)	J24-4 (2 terminals)

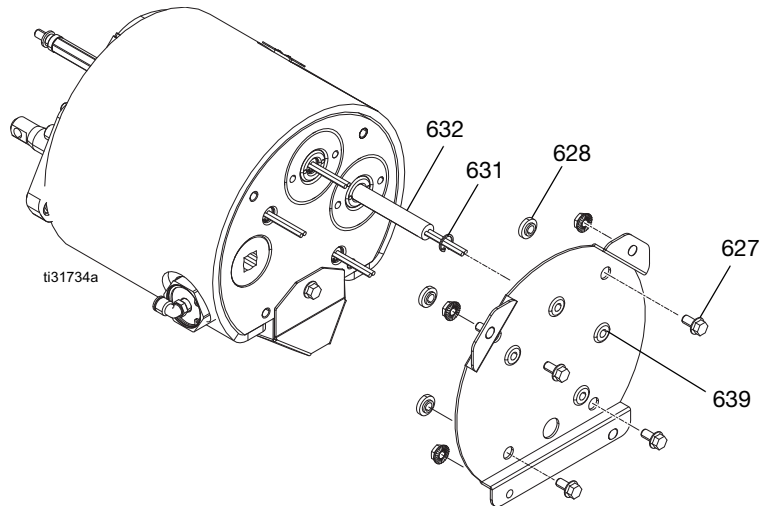

Replace Electrical Component(s)

DANGER
SEVERE ELECTRIC SHOCK HAZARD
 This equipment can be powered by more than 240V. Contact with this voltage will cause death or serious injury.

- Turn off and disconnect power at main switch before disconnecting any cables and before servicing equipment.

- Remove electrical enclosure door (332)
- Use a non-conductive fuse puller tool to remove the blown fuse.

Using an improper tool, such as a screwdriver or pliers may break fuse or cause damage to board.

NOTE: Fuses FHA and FHB are not replaceable. If FHA or FHB fuses are blown, order **AMZ Replacement Kit, 25M525**.

Replace Auto Multi-Zone (AMZ) Fuse(s)

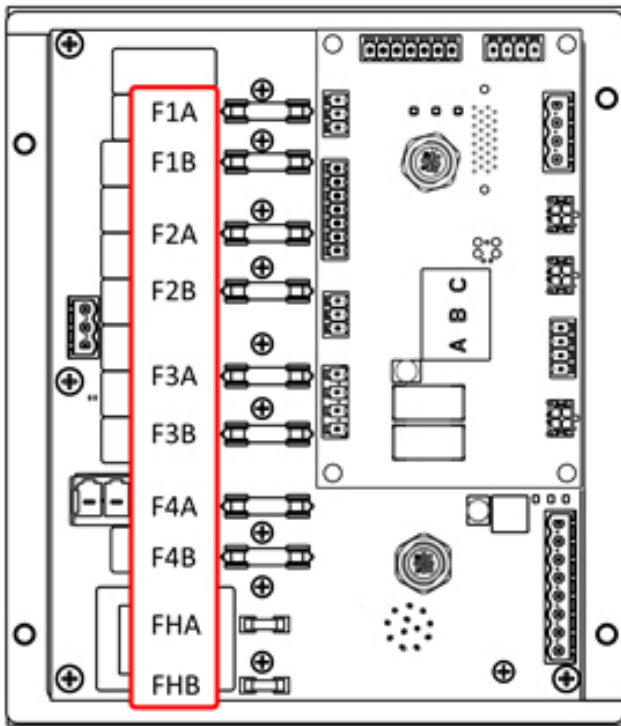

- Install a new fuse into the empty fuse holder.
- Install electrical enclosure door (332).

Replace Auto Multi-Zone (AMZ)

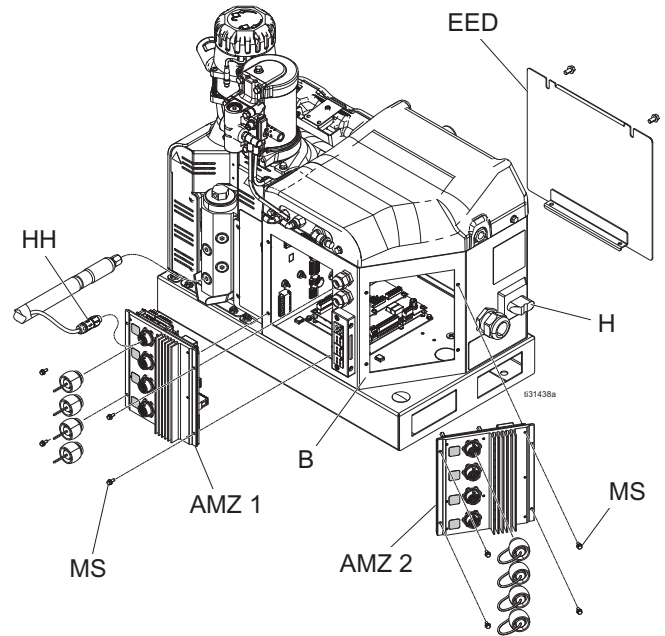

To prevent system damage, always use fast acting fuses. Fast acting fuses are required for short-circuit protection.

- Turn the main power switch (H) OFF.
- Remove electrical enclosure door (EED).
- Remove AMZ:
 - Disconnect heated hose electrical connections (HH) from the back of the AMZ.
 - Disconnect cables from the AMZ on the inside of the electrical enclosure (B).
 - Remove the four screws (MS) used to mount the AMZ to the back of the electrical enclosure (B) and remove the AMZ.

Fuse	Part	Identification
F1A-F4B	129346	250VAC, 12.5A, fast acting
FHA-FHB	-----	250VAC, 25A

- Turn main power switch (H) OFF.

4. Insert the new AMZ:
 - a. Set the AMZ dial position according to the image below.

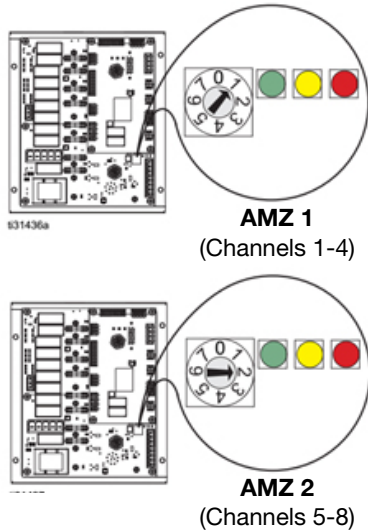

- b. Mount the AMZ to the back of the electrical enclosure (B) using the four screws (MS) removed from the original AMZ.
 - c. Reconnect the cables on the inside of the electrical enclosure (B) to the AMZ. See **Electrical Schematics** on page 54 for connections.
 - d. Reconnect the heated hose electrical connections (HH) to the back AMZ.
5. Replace the electrical enclosure door (EED).

Replace Advanced Display Module (ADM)

The ADM stores useful lifetime and diagnostic data that will be lost when it is replaced. To keep this data, perform a USB download prior to replacing the ADM.

1. Turn the main power switch (H) OFF.
2. Disconnect cable (103) from the bottom of the ADM.
3. Remove ADM (335) from bracket (334). See **Parts** on page 58.
4. Install new ADM (335) into bracket (334).
5. Connect cable (103) to the bottom of new ADM (335).

Replace the Pattern Control Module (PCM)

1. Turn the main power switch (H) OFF.
2. Remove the electrical enclosure door (332). See **Parts** on page 58.
3. Disconnect cables from PCM (309).
4. Remove four mounting screws (304) and remove PCM (309).
5. Install the new PCM (309) on the bottom of electrical enclosure (B) using four mounting screws (304) removed in the previous step.
6. Connect the cables removed previously to the new PCM (309).
7. Install electrical enclosure door (332).

Replace the Power Supply

1. Turn the main power switch (H) OFF.
2. Remove electrical enclosure door (332). See **Parts** on page 58.
3. Disconnect power supply cables from AMZ 1 (headers J3 and J21).
4. Remove the power supply (5) from electrical enclosure (B) by removing the four mounting nuts (29) used to mount the power supply (5) to the top of the electrical enclosure (B).
5. Disconnect power supply cables from J3 and J21 plugs.
6. Make connections between new power supply cables and J3 and J21 plugs. See **Electrical Schematics** on page 54 for connections.
7. Mount the new power supply (5) to the top of the electrical enclosure (B) using the previously removed four mounting nuts (29).
8. Connect power supply cables AMZ 1 (headers J3 and J21).
9. Install electrical enclosure door (332).

Electrical Schematics



DANGER

SEVERE ELECTRIC SHOCK HAZARD

This equipment can be powered by more than 240V. Contact with this voltage will cause death or serious injury.

- Turn off and disconnect power at main switch before disconnecting any cables and before servicing equipment.
- This equipment must be grounded. Connect only to grounded power source.
- All electrical wiring must be done by a qualified electrician and comply with all local codes and regulations.

Common Schematic (all systems)

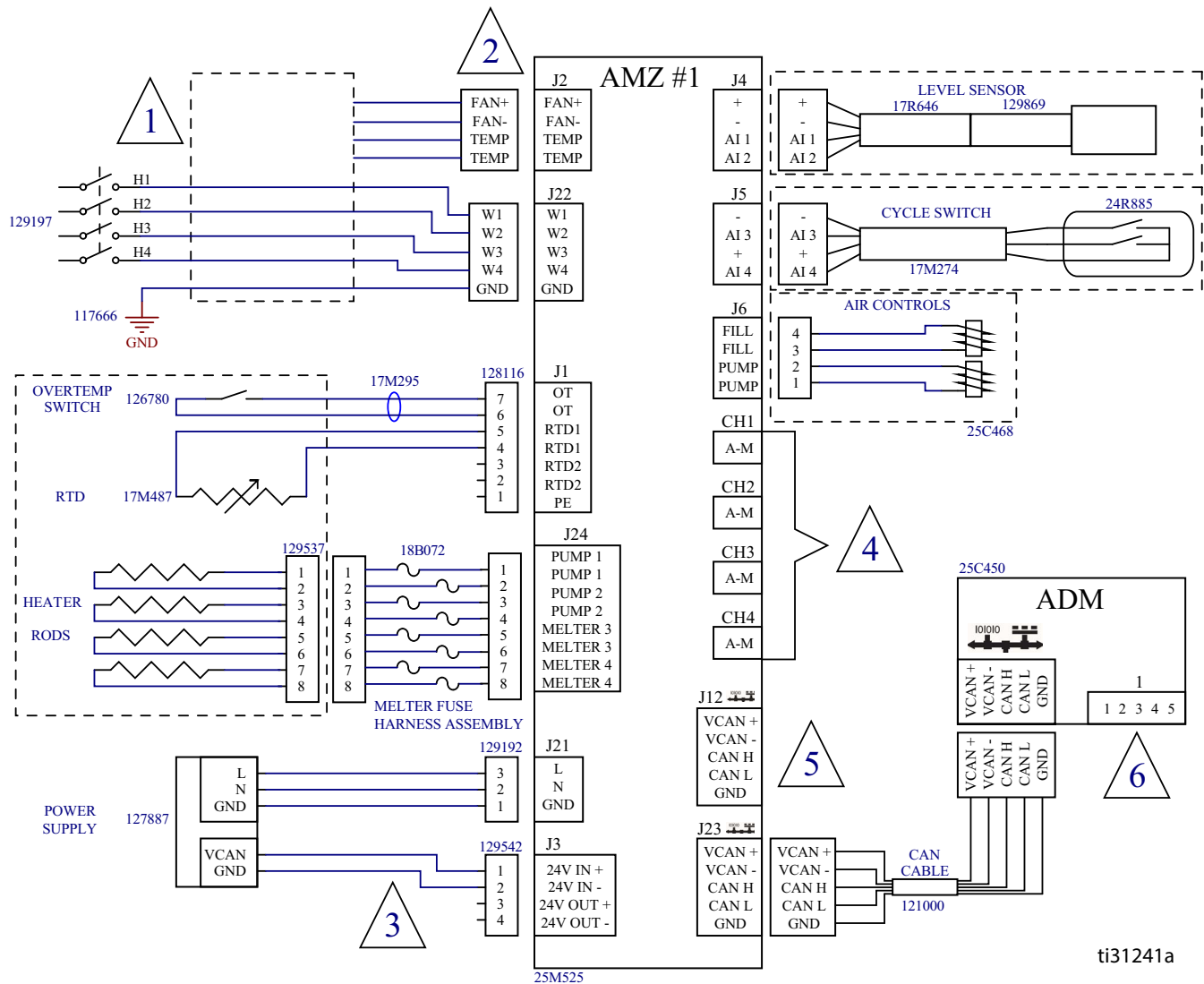

① See **Incoming Power**, page 55.

② Fan connector not present on all systems.

③ See **Pattern Controller**, page 56.

④ See **Typical Hose/Applicator Wiring**, page 57.

⑤ See **Pattern Controller**, page 56 and **8-Channel Systems**, page 56.

⑥ Optional light tower accessory.

Incoming Power

25C700, 25C701
(240V, 4 CHANNEL SYSTEMS)

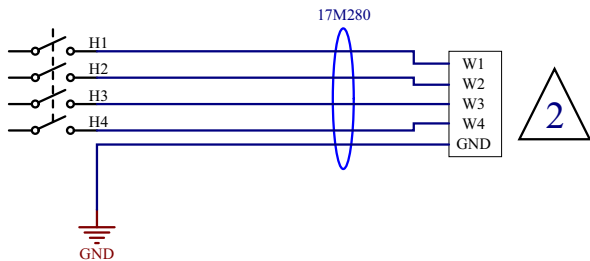

25C702, 25C703
(240V, 8 CHANNEL SYSTEMS)

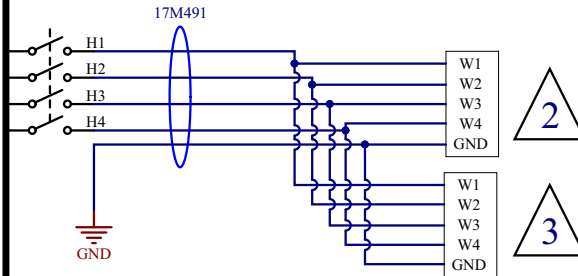

ti31242a

25C720, 25C721
(480V, 4 CHANNEL SYSTEMS)

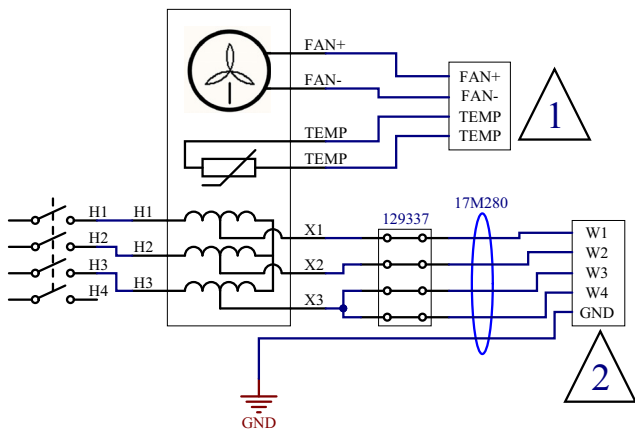

25C722, 25C723
(480V, 8 CHANNEL SYSTEMS)

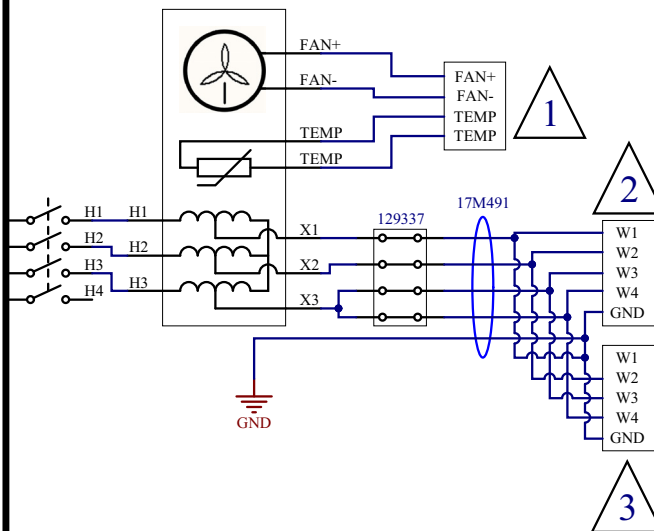

- △1 Connects to AMZ #1 - J2.
- △2 Connects to AMZ #1 - J22.
- △3 Connects to AMZ #2 - J22.

8 Channel Systems (25C702, 25C703, 25C722, 25C723)

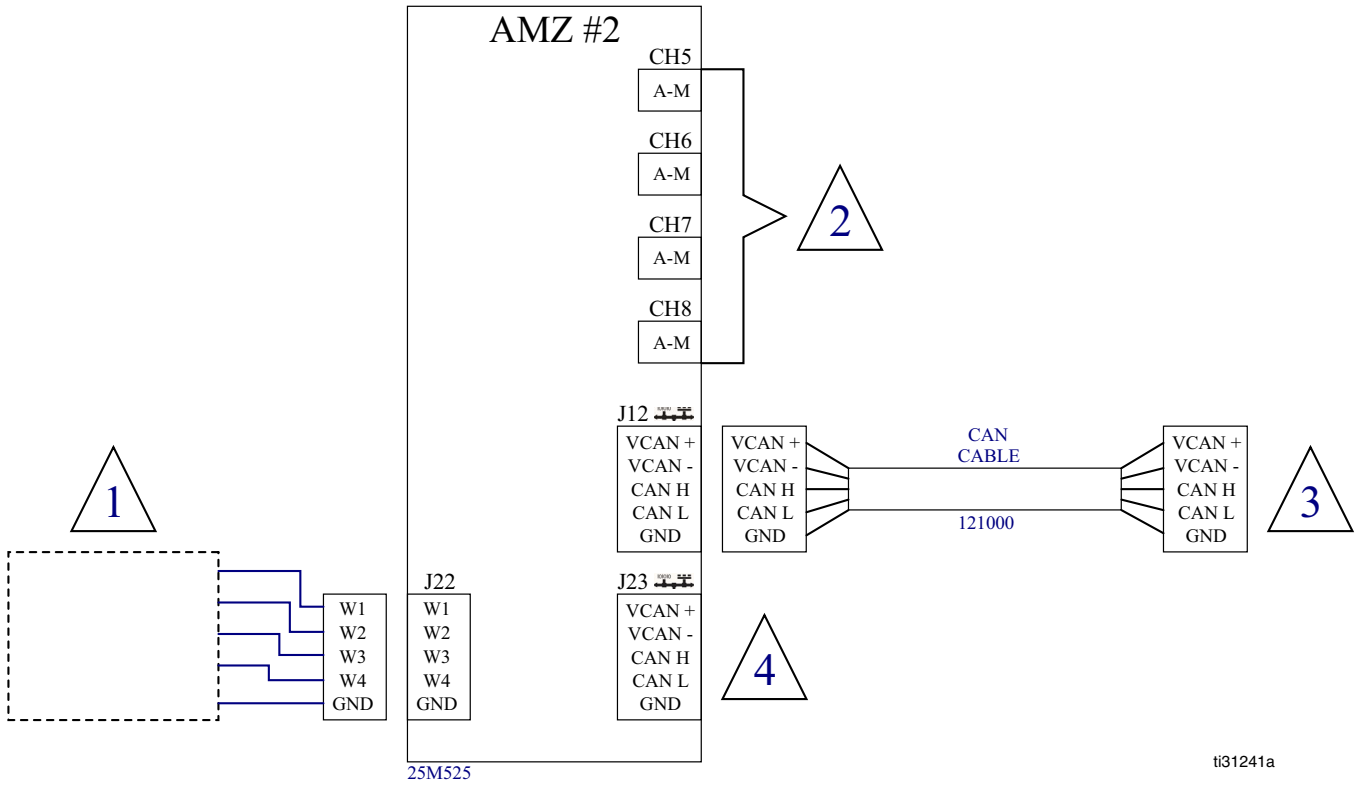

- △ 1 See **Incoming Power**, page 55.
- △ 2 See **Typical Hose/Applicator Wiring**, page 57.
- △ 3 Connected to AMZ #1 - J12.
- △ 4 See **Pattern Controller**, page 56.

Pattern Controller

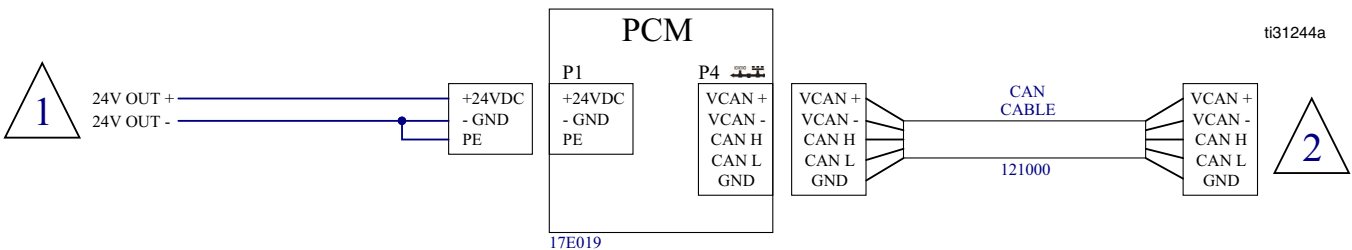

- △ 1 Connects to "24V Out+" and "24V Out -" on AMZ #1 - J3.
- △ 2 4 Channel systems (25C701, 25C721): Connects to AMZ #1 - J12.
8 channel system (25C703, 25C723): Connects to AMZ #2 - J23.

Typical Hose/Applicator Wiring

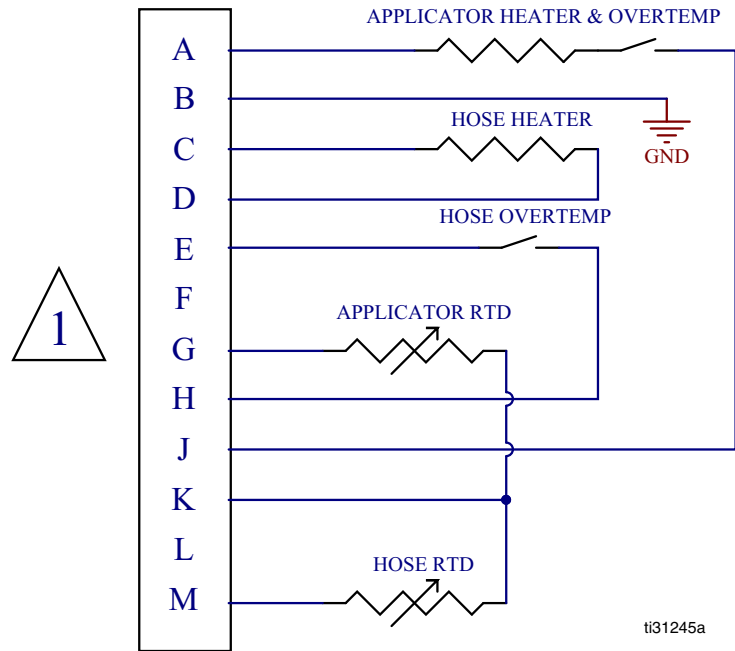

△ Connects to Ch1-4 on AMZ #1 and Ch5-8 on AMZ #2.

Air Control Schematic

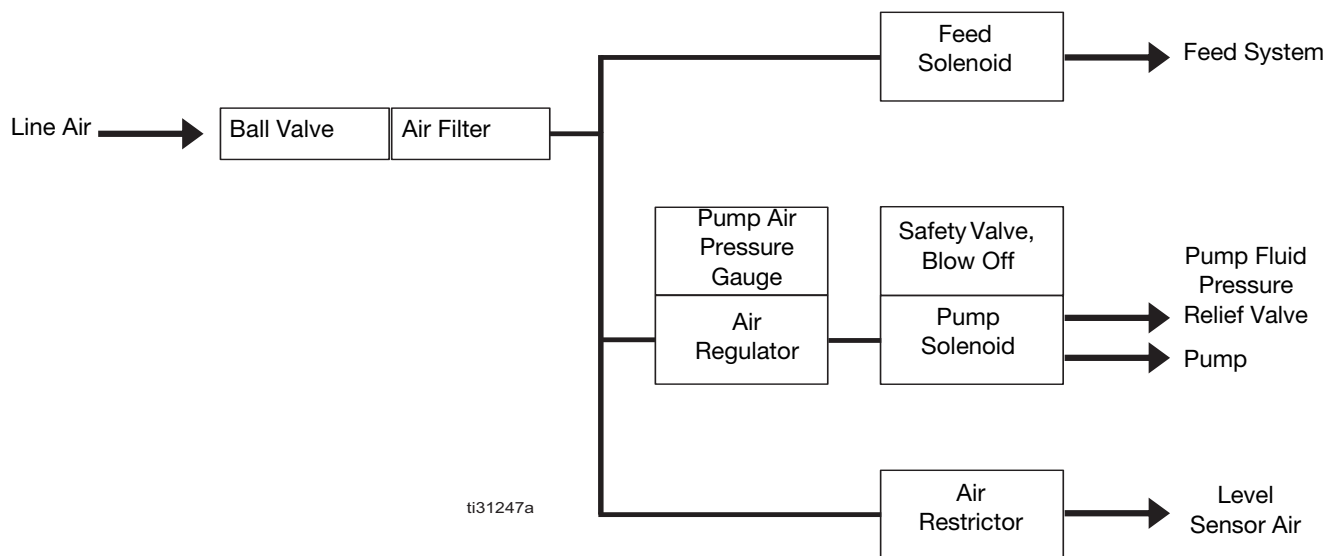

Parts

Common System Parts

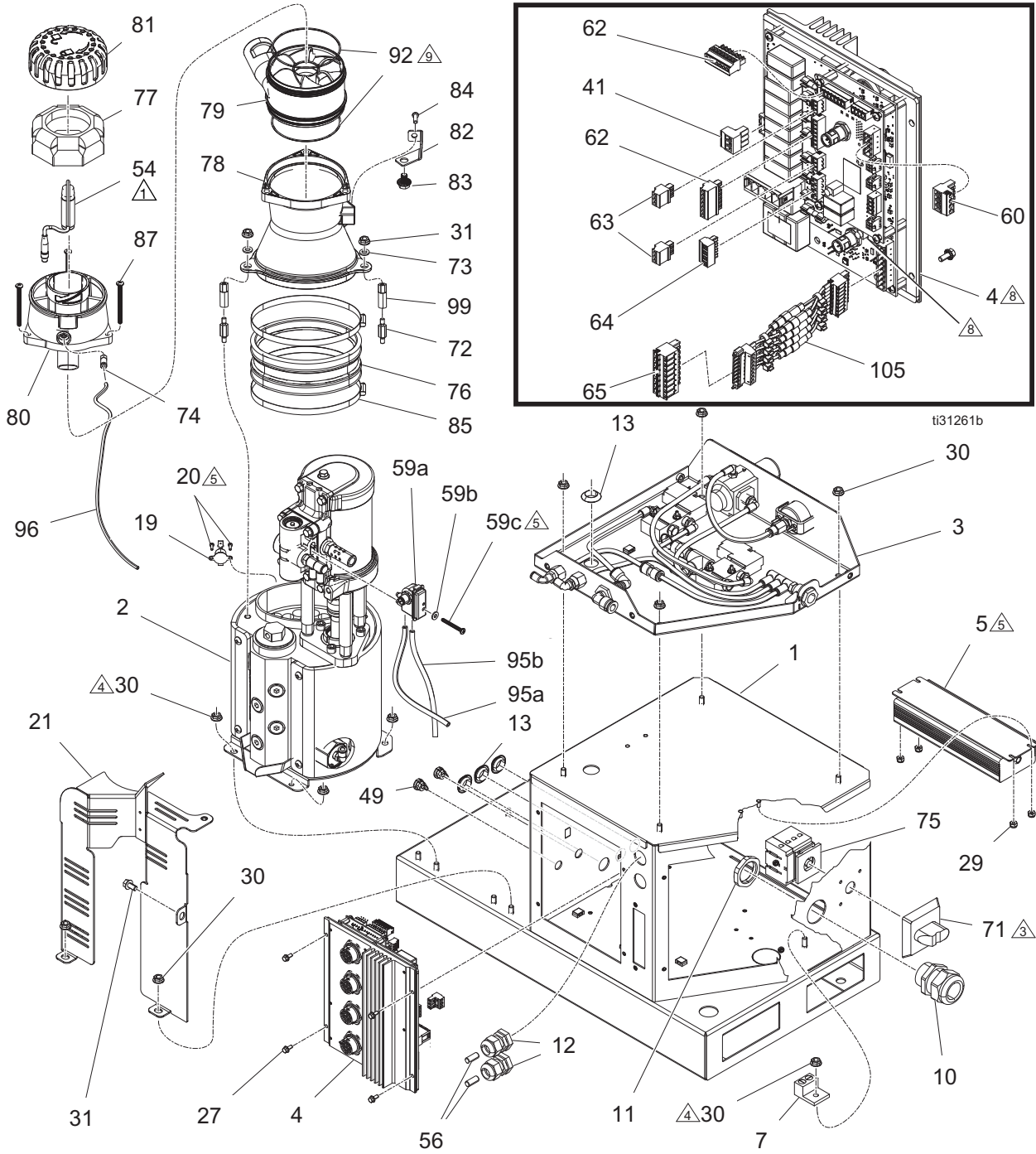

Common System Parts List

Ref.	Part	Description	Qty.	Ref.	Part	Description	Qty.
1	-----	ENCLOSURE, electrical, painted	1	78*	278870	FUNNEL, base	1
2†	17S257	KIT, pump, mnfld, assy, HM25C	1	79*	278871	FUNNEL, inlet, HM25c	1
3	25C468	CONTROL, air, assembly	1	80*	-----	HOUSING, sensor, HM25c	1
4	25M525	KIT, repair, AMZ	1	81*	278873	CAP, filter, funnel, HM25c	1
5❖	25T776	KIT, power supply, 24 DC, 6.3 A 151.2 W	1	82	17R610	BRACKET, funnel, painted	1
7	117666	TERMINAL, ground	1	83	129746	BOLT, flange hd, serrated, m8	1
10	126881	BUSHING, strain relief	1	84	126901	SCREW, #10-16, thread forming	1
11	126891	NUT, bushing	1	85	129658	CLAMP, hose, worm drive	2
12	114421	BUSHING, strain relief	2	86	116610	SCREW, mach, phil, pan, #10	2
13	121487	GROMMET, sheet metal, 3/4 in.	4	87*	130165	SCREW, mach, pnh, 10-32 x 2.5 in.	3
19	126780	SWITCH, over temperature	1	92*	129813	O-RING, Viton, 043	2
20	107388	SCREW, mach, pnh	2	94	17R646	CABLE, M8, Molex	1
21	17R874	BRACKET, shroud, mltr, HM25c, painted	1	95	-----	TUBE, ptfe, 1/4 in. OD	2
27	125856	SCREW, 8-32, serrated flange	4	96	598095	TUBE, 5/32 OD, nylon	1.34 in.
29	109466	NUT, lock, hex	4	99◆	-----	POST, standoff, insulator	2
30	115942	NUT, hex, flange head	13	100	17M487	SENSOR, 1000 ohm rtd (not shown)	1
31◆	113161	SCREW, flange, hex hd	1	101	17M295	HARNESS, ot (not shown)	1
35	17M487	SENSOR, 1000 ohm rtd	1	102	17M274	CABLE, M12 (not shown)	1
36	17M295	HARNESS, ot	1	103	121000	CABLE, can, female/female 0.5 mm (not shown)	2
38	17M274	CABLE, M12, Molex	2	104	17R646	CABLE, M8 (not shown)	1
41	129192	CONNECTOR, plug, 5.08 mm, 3 position	1	105**	-----	HARNESS, assembly, fuse holder, 8 leads	1
49	129598	GRIP, cord, snap-in	2				
54	129869	SENSOR, ultrasonic, m8 (level sensor)	1				
56	-----	PIN, dowel	2				
57	102360	WASHER, flat	1				
58	-----	SCREW, pan head, #8-32 x 1.5 in.	1				
59	-----	SWITCH, reed, assy (cycle switch)	1				
60	129542	CONNECTOR, plug, 5.08 mm 4 position	1				
62	128116	CONNECTOR, plug, 3.81 mm, 7 position	2				
63	129539	CONNECTOR, plug, 3.81 mm 3 position	2				
64	129541	CONNECTOR, plug, 5.08 mm 4 position	1				
65	129537	CONNECTOR, plug, 5.08 mm 8 position	1				
67	129538	CONNECTOR, plug, 3.81 mm 4 position	1				
71	123967	KNOB, operator disconnect	1				
72◆	-----	ROD, standoff, 0.750	2				
73◆	16D984	WASHER, g3, ll	2				
74*	110932	CONNECTOR, male	1				
75	129197	SWITCH, disconnect, 40A	1				
76	129657	ADAPTER, funnel/melter, gen 3	1				
77*	129908	FILTER, air, funnel, coarse	1				

† Kit includes part No. 054986, 1/4 in. PTFE tubing

* Included in funnel kit 17S259

** Included in fuse harness kit 25P567

◆ Included in funnel stand off kit 25T647

❖ Included in 24VDC power supply kit 25T776

△₁ Bottom out sensor (54) then back off 1/2 turn. Tighten the jam nut to secure.

△₃ Punch inside holes and install using screws supplied with (71).

△₄ Torque to 100 +/- 10 in-lb (11 +/- 1 N•m).

△₅ Torque to 7-10 in-lb (0.7-1 N•m).

△₈ Rotary switch is to be set to "1" ON.

△₉ Lubricate o-rings.

Common System Parts (continued)

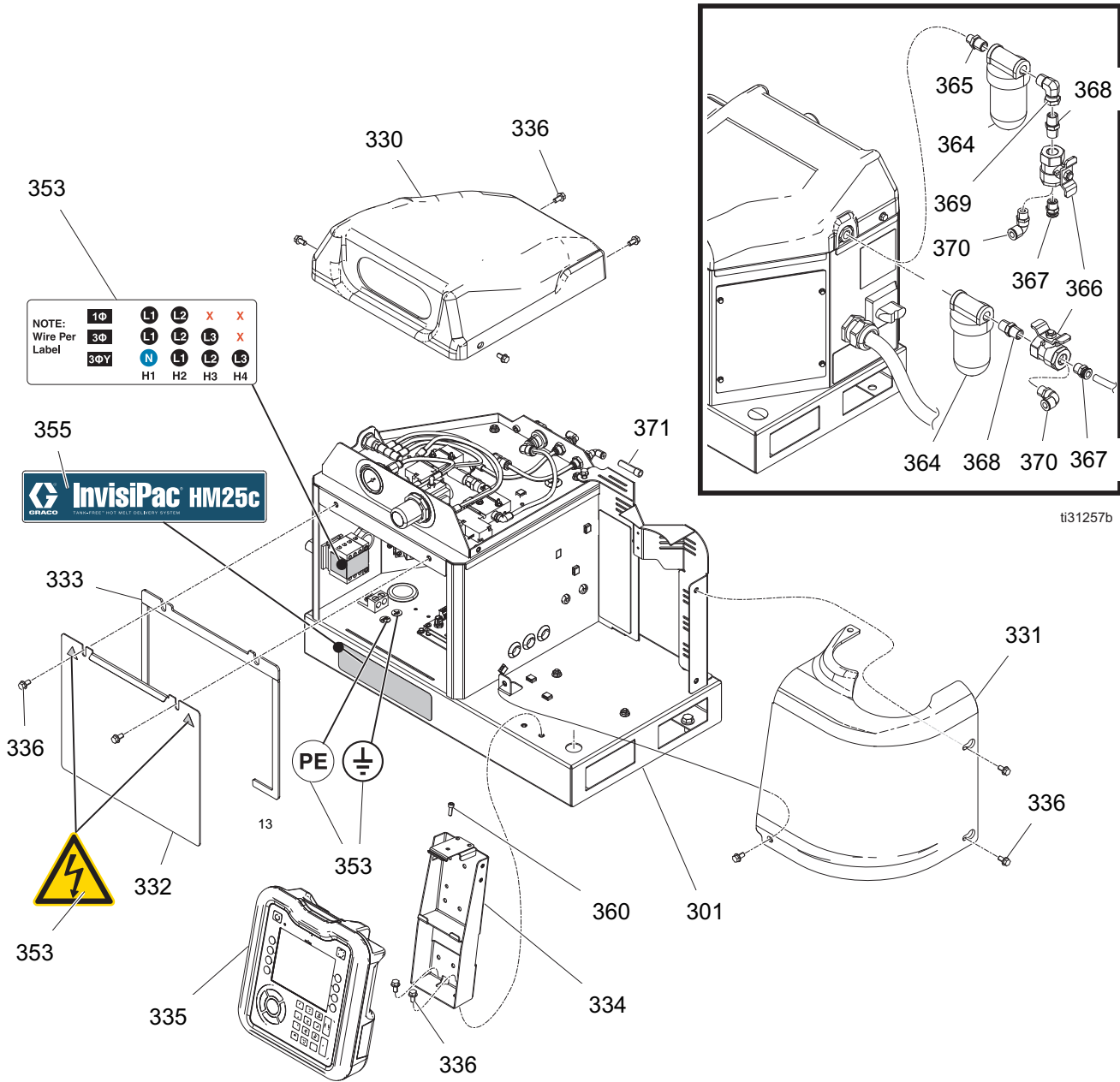

Common System Parts List (continued)

Ref.	Part	Description	Qty.
301	-----	SYSTEM, base, HM25c	1
302	24P175	PLATE, blank, sgl mztcm, painted	1
303	-----	GASKET, foam, mztcm	1
304	125856	SCREW, 8-32, serrated flange	4
305	-----	PLATE, block off, pc, painted	1
306	-----	GASKET, foam, block off, pc	1
307	-----	SCREW, cap, socket hd, #10-32 x .75	2
308	17M280	HARNESS, disconnect	1
328	16T440	CAP, souriau, uts14	4
330	17R967	COVER, air control, painted	1
331	17R912	COVER, melter, hm25c, painted	1
332	-----	DOOR, front, painted	1
333	-----	FOAM, gasket, door	1
334	-----	BRACKET, adm, HM25c, painted	1
335	-----	MODULE,GCA, adm	1
336	113161	SCREW, flange, hex hd	12
338	114606	PLUG, hole	2
342	-----	BAG, mailer	1
343	129346	FUSE, 250V, 12.5 A	10
344	129189	TOOL, puller, fuse	1
345	116793	FITTING	4
346	-----	FITTING, straight, hydraulic	4
347	-----	FITTING	4

✘ *Not shown.*

▲ *Replacement Danger and Warning labels are available at no cost.*

8-Channel, Pattern Controller, and 480V System Parts

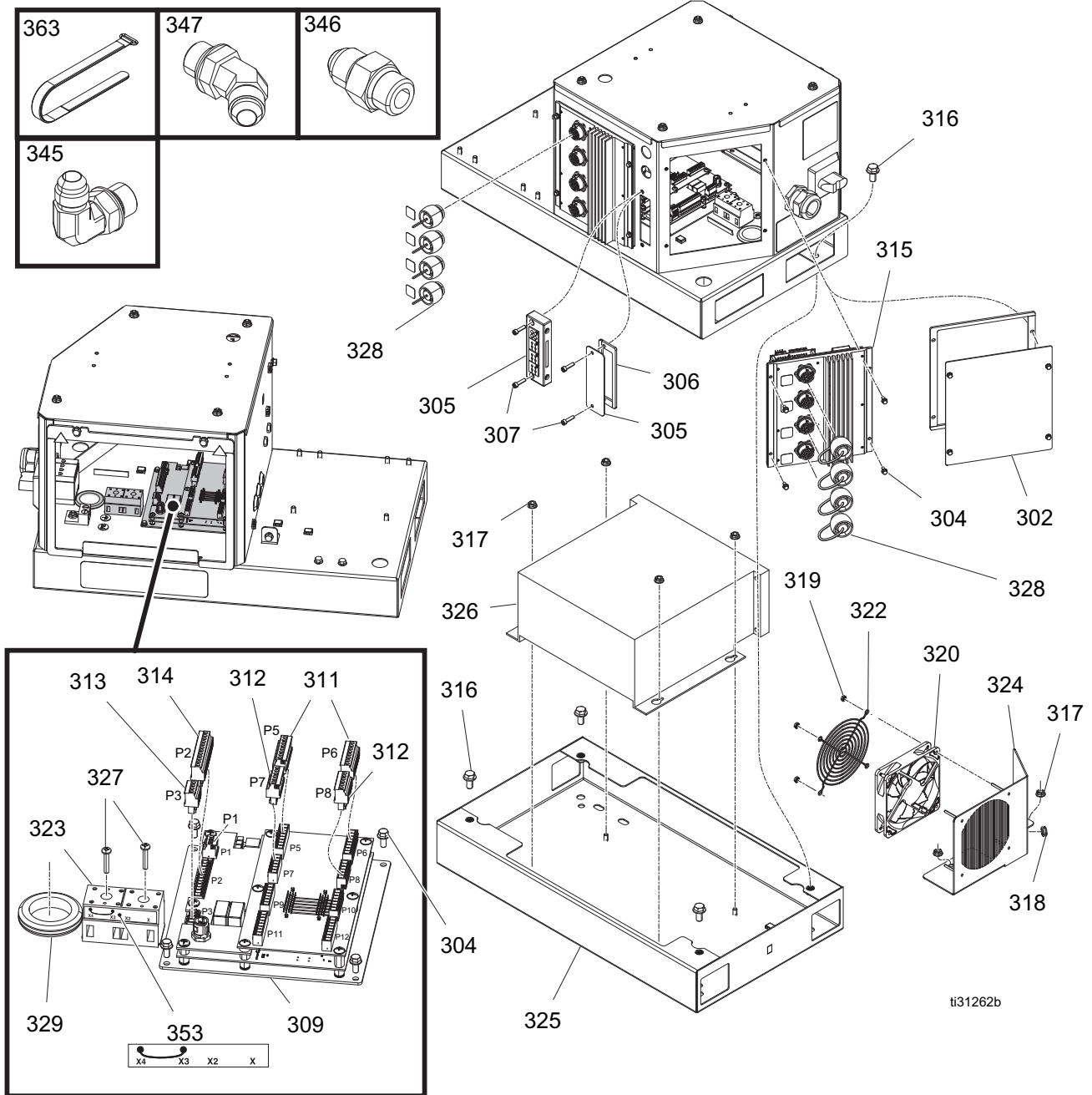









8-Channel, Pattern Controller, and 240V System Parts List

		240V Systems							
		4-channel				8-Channel			
		no PC		with PC		no PC		with PC	
Ref.	Description	Part	Qty.	Part	Qty.	Part	Qty.	Part	Qty.
304	SCREW, 8-32, serrated flange	125856	4	125856	8	125856	4	125856	8
305	FRAME, cord grip, 4-position	-----	1	129594	1	-----	1	129594	1
307	SCREW, cap, socket hd, #10-32 x .75	-----	2	-----	2	-----	2	-----	2
308	HARNESS, disconnect (not shown)	17M280	1	17M280	1	17M491	1	17M491	1
309	KIT, pattern control board	-----	-	17E019	1	-----	-	17E019	1
310	HARNESS, PC-8 internal (not shown)	-----	-	17M504	1	-----	-	17M504	1
311	CONNECTOR, plug, 8 position	-----	-	128147	2	-----	-	128147	2
312	CONNECTOR, plug, 6 position	-----	-	129540	2	-----	-	129540	2
313	CONNECTOR, plug, 4 position	-----	-	129538	1	-----	-	129538	1
314	CONNECTOR, plug, 12 position	-----	-	128117	1	-----	-	128117	1
315	MODULE, GCA, AMZ w DB	25M525	1	25M525	1	25M525	2	25M525	2
316	SCREW, cap, flange head	-----	-	-----	-	-----	-	-----	-
317	NUT, hex, flange head	-----	-	-----	-	-----	-	-----	-
318	GROMMET, 1/4 ID	-----	-	-----	-	-----	-	-----	-
319	NUT, KEPS, hex	-----	-	-----	-	-----	-	-----	-
320	FAN, 24VDC, 120 mm x 120 mm	-----	-	-----	-	-----	-	-----	-
322	GUARD, fan, 120 mm	-----	-	-----	-	-----	-	-----	-
323	BLOCK, terminal	-----	-	-----	-	-----	-	-----	-
324	PLATE, fan, transformer	-----	-	-----	-	-----	-	-----	-
325	BASE, transformer enclosure	-----	-	-----	-	-----	-	-----	-
326	TRANSFORMER, 480V	-----	-	-----	-	-----	-	-----	-
327	SCREW	-----	-	-----	-	-----	-	-----	-
328	CAP, Souriau	16T440	4	16T440	4	16T440	8	16T440	8
329	GROMMET	-----	-	-----	-	-----	-	-----	-
345	FITTING	-----	4	-----	4	-----	8	-----	8
☼									
346	FITTING, straight, hydraulic	-----	4	-----	4	-----	8	-----	8
☼									
347	FITTING, 45 elbow, hydraulic	-----	4	-----	4	-----	8	-----	8
☼									
348	FITTING, tee	-----	-	-----	-	127208	2	127208	2
353	LABEL, safety, multiple	17P381	1	17P381	1	17P381	1	17P381	1
▲									
363	STRAP, retaining	114271	20	114271	20	114271	30	114271	30
364	CABLE, CAN, female/female 0.5 m	-----	-	121000	1	121000	1	121000	2
<p>☼ Included in fittings kit 24V504, 6 each.</p> <p>▲ Replacement Danger and Warning labels are available at no cost.</p>									

8-Channel, Pattern Controller, and 480V System Parts List



		480V Systems							
		4-channel				8-Channel			
		no PC		with PC		no PC		with PC	
Ref.	Description	Part	Qty.	Part	Qty.	Part	Qty.	Part	Qty.
304	SCREW, 8-32, serrated flange	125856	4	125856	8	125856	4	125856	8
305	FRAME, cord grip, 4-position	-----	1	129594	1	-----	1	129594	1
307	SCREW, cap, socket hd, #10-32 x .75	-----	2	-----	2	-----	2	-----	2
308	HARNESS, disconnect (not shown)	17M280	1	17M280	1	17M491	1	17M491	1
309	KIT, pattern control board	-----	-	17E019	1	-----	-	17E019	1
310	HARNESS, PC-8 internal (not shown)	-----	-	17M504	1	-----	-	17M504	1
311	CONNECTOR, plug, 8 position	-----	-	128147	2	-----	-	128147	2
312	CONNECTOR, plug, 6 position	-----	-	129540	2	-----	-	129540	2
313	CONNECTOR, plug, 4 position	-----	-	129538	1	-----	-	129538	1
314	CONNECTOR, plug, 12 position	-----	-	128117	1	-----	-	128117	1
315	MODULE, GCA, AMZ w DB	25M525	1	25M525	1	25M525	2	25M525	2
316	SCREW, cap, flange head	112395	4	112395	4	112395	4	112395	4
317	NUT, hex, flange head	115942	4	115942	4	115942	4	115942	4
318	GROMMET, 1/4 ID	-----	1	-----	1	-----	1	-----	1
319	NUT, KEPS, hex	127278	4	127278	4	127278	4	127278	4
320	FAN, 24VDC, 120 mm x 120 mm	127421	1	127421	1	127421	1	127421	1
322	GUARD, fan, 120 mm	-----	1	-----	1	-----	1	-----	1
323	BLOCK, terminal	129337	1	129337	1	129337	1	129337	1
324	PLATE, fan, transformer	-----	1	-----	1	-----	1	-----	1
325	BASE, transformer enclosure	-----	1	-----	1	-----	1	-----	1
326	TRANSFORMER, 480V	-----	1	-----	1	-----	1	-----	1
327	SCREW	-----	2	-----	2	-----	2	-----	2
328	CAP, Souriau	16T440	4	16T440	4	16T440	8	16T440	8
329	GROMMET	-----	1	-----	1	-----	1	-----	1
345	FITTING	-----	4	-----	4	-----	8	-----	8
✿									
346	FITTING, straight, hydraulic	-----	4	-----	4	-----	8	-----	8
✿									
347	FITTING, 45 elbow, hydraulic	-----	4	-----	4	-----	8	-----	8
✿									
348	FITTING, tee	-----	-	-----	-	127208	2	127208	2
353	LABEL, safety, multiple	17P381	1	17P381	1	17P381	1	17P381	1
▲									
363	STRAP, retaining	114271	20	114271	20	114271	30	114271	30
364	CABLE, CAN, female/female 0.5 m	-----	-	121000	1	121000	1	121000	2
✿ Included in fittings kit 24V504, 6 each.									
▲ Replacement Danger and Warning labels are available at no cost.									

Safety and Identification Labels

⚠ WARNING	
	BURN HAZARD To avoid severe burns: • Do not touch hot fluid or equipment.
	SKIN INJECTION HAZARD High-pressure spray or leaks can inject fluid into the body. • Keep clear of fluid outlet and leaks. • Follow pressure relief procedure before servicing or cleaning. • In case of skin injection, get immediate SURGICAL TREATMENT.
	READ INSTRUCTION MANUAL. FAILURE TO FOLLOW THIS WARNING CAN RESULT IN SERIOUS INJURY, AMPUTATION OR DEATH.
⚠ AVERTISSEMENT	
	RISQUES DE BRÛLURE Pour éviter de graves brûlures : • Ne touchez pas l'équipement ni le fluide lorsqu'ils sont chauds.
	RISQUES D'INJECTION CUTANÉE La pulvérisation sous haute pression ou les fuites peuvent causer une injection de produit dans le corps. • Éloignez-vous de la sortie et des fuites de fluide. • Suivez la procédure d'évacuation de la pression avant l'entretien ou le nettoyage. • En cas d'injection cutanée, consultez immédiatement un médecin pour une INTERVENTION CHIRURGICALE.
	LIRE LE MANUEL D'INSTRUCTIONS. LE NON-RESPECT DE CET AVERTISSEMENT PEUT ENTRAÎNER DES BLESSURES GRAVES, UNE AMPUTATION, VOIRE LA MORT .
⚠ ADVERTENCIA	
	PELIGRO DE QUEMADURAS Para evitar las quemaduras graves: • No toque el fluido o el equipo caliente.
	PELIGRO DE INYECCIÓN A TRAVÉS DE LA PIEL La pulverización o las fugas a alta presión pueden inyectar fluido en el cuerpo. • Manténgase alejado de la salida y fugas de fluido. • Siga el procedimiento de descompresión antes de realizar tareas de mantenimiento o limpieza. • En caso de que se produzca la inyección en la piel, consiga inmediatamente TRATAMIENTO QUIRÚRGICO.
	LEA EL MANUAL DE INSTRUCCIONES. NO RESPETAR ESTA ADVERTENCIA PUEDE OCASIONAR LESIONES GRAVES, AMPUTACIÓN E INCLUSO LA MUERTE.

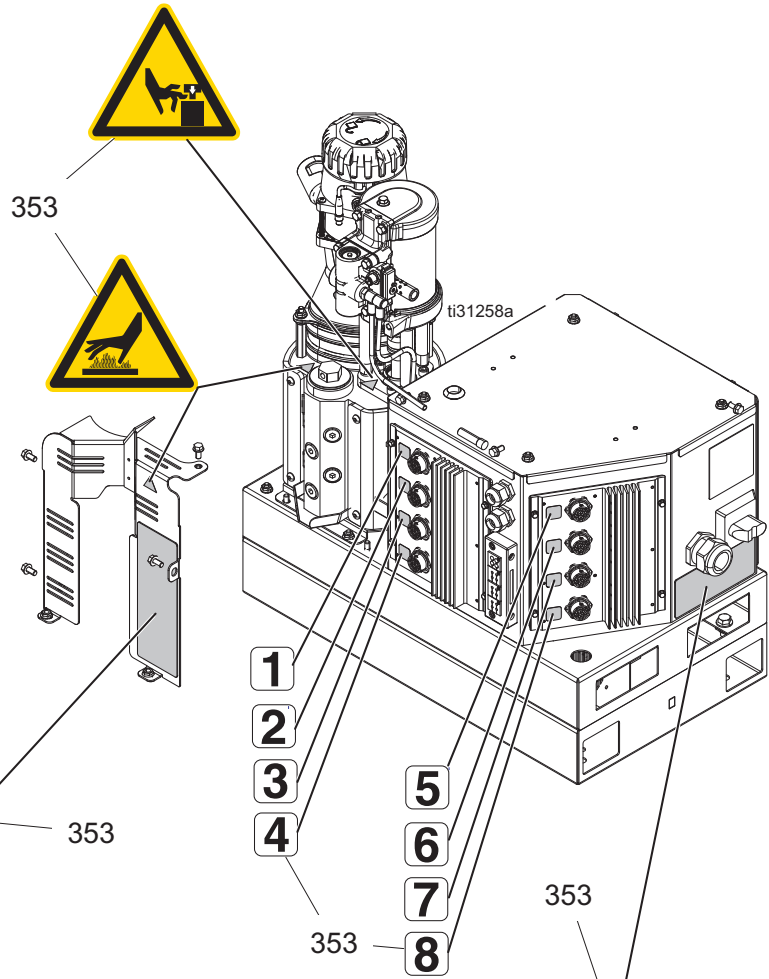
17P381 Rev. E



17P381 Rev. E	⚠ DANGER	⚠ DANGER	⚠ PELIGRO
	HIGH VOLTAGE ELECTRIC SHOCK HAZARD Contact with high voltage equipment will cause death or serious injury. • Disconnect power source before servicing or installing. • Connect to grounded power source. • Service by a qualified electrician.	RISQUES DE DÉCHARGE ÉLECTRIQUE DE HAUTE TENSION Le contact avec des équipements à haute tension entraîne des blessures graves, voire la mort. • Couper l'alimentation électrique avant l'entretien ou l'installation de l'appareil. • Brancher uniquement sur une prise de courant raccordée à la terre. • À faire entretenir par un électricien qualifié.	PELIGRO DE DESCARGA ELÉCTRICA DE ALTO VOLTAJE El contacto con equipos de alta tensión puede provocar lesiones graves o incluso la muerte. • Desconecte la fuente de alimentación antes de instalar o llevar a cabo tareas de servicio técnico. • Conecte a una fuente de alimentación conectada a tierra. • Un electricista calificado debe llevar a cabo las tareas de servicio técnico.
	READ INSTRUCTION MANUAL FAILURE TO FOLLOW THIS WARNING CAN RESULT IN SERIOUS INJURY OR DEATH.	LIRE LE MANUEL D'INSTRUCTION LE NON RESPECT DE CET AVERTISSEMENT PEUT RÉSULTER EN DE SÉRIEUSES BLESSURES OU LA MORT.	LEA EL MANUAL DE INSTRUCCIONES LA INOBSERVANCIA DE ESTA ADVERTENCIA PUEDE PROVOCAR UNA LESIÓN GRAVE O LA MUERTE.

Safety and Identification Labels

Ref.	Part	Description	Qty.
353▲	17P381	LABEL, safety, danger, multiple	1

▲Replacement Danger and Warning labels are available at no cost.

Air Control Assembly 25C468 Parts

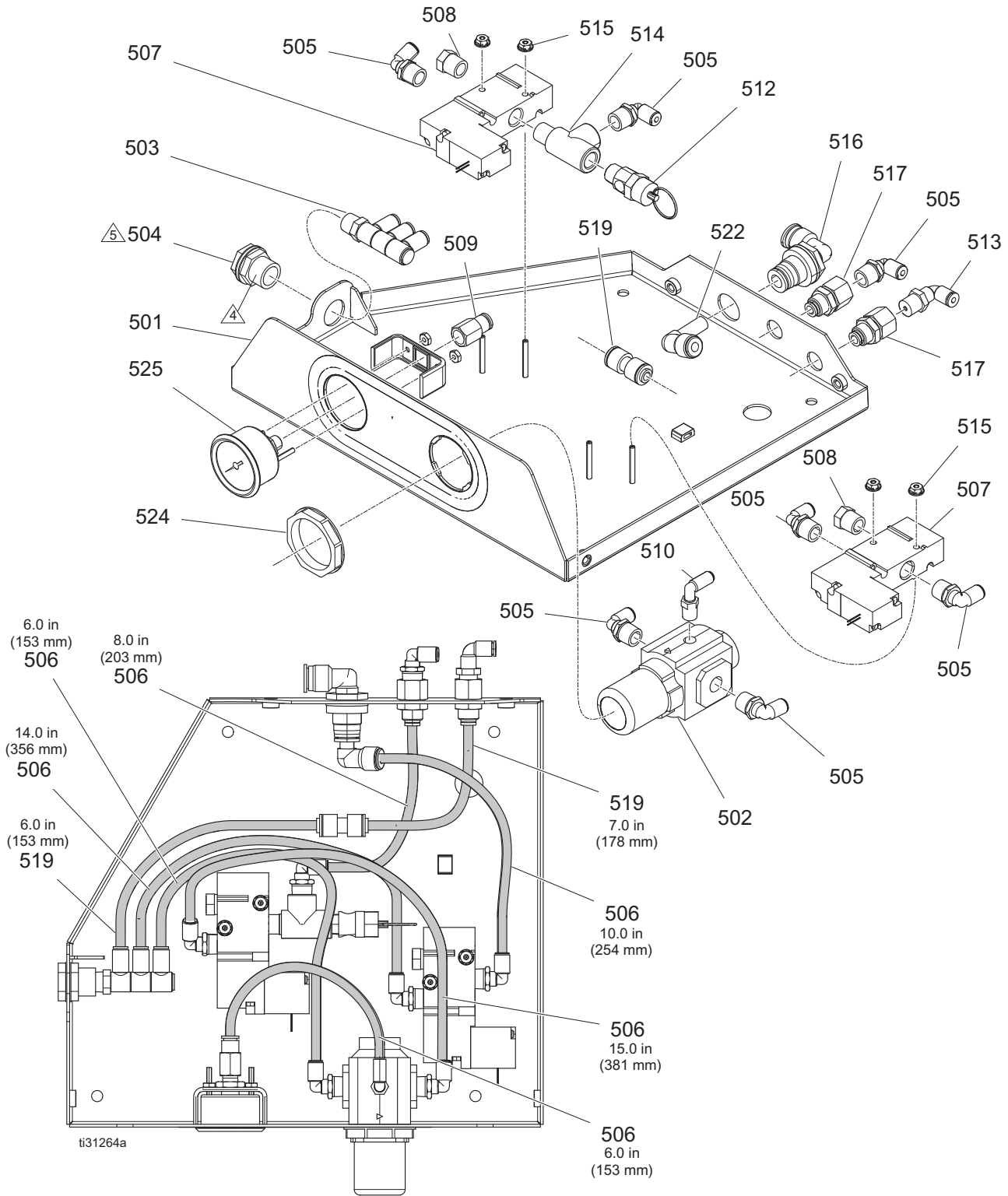

Air Control Assembly 25C468 Parts List

Ref.	Part	Description	Qty.
501	-----	BRACKET, top, air controls	1
502	129805	REGULATOR, air	1
503	-----	FITTING, triple union, 1/4 tube	1
504	104641	FITTING, bulkhead	1
505	110937	FITTING, elbow	7
506	C12509	TUBE, nylon, rnd	6
507	129477	VALVE, solenoid, 3 way	2
508	121021	VENT, breather, muffler	2
509	114320	FITTING, connector, female, 1/8 NPT	1
510	111162	FITTING, elbow	1
512	113498	VALVE, safety, 110 psi	1
513	15T937	FITTING, elbow, swivel 1/4 npt x 5/32 t	1
514	106228	FITTING, tee, street	1
515	128672	NUT, serrated flange, #6-32, sst	4
516	-----	FITTING, elbow, PTC, 3/8	1
517	-----	BULKHEAD, 1/4 NPT x 1/4 tube	2
519	129902	RESTRICTOR, .023, 1/4 tube x 1/4 tube	1
522	-----	FITTING, 3/8 x 1/4 elbow	1
524	116514	NUT, regulator mnt	1
525	128260	GAUGE, panel mount	1

 Apply sealant to external threads.

 Torque to 25 +/- 5 in-lb (2.8 +/- 0.5 N•m).

Melter Assembly 17S257 Parts

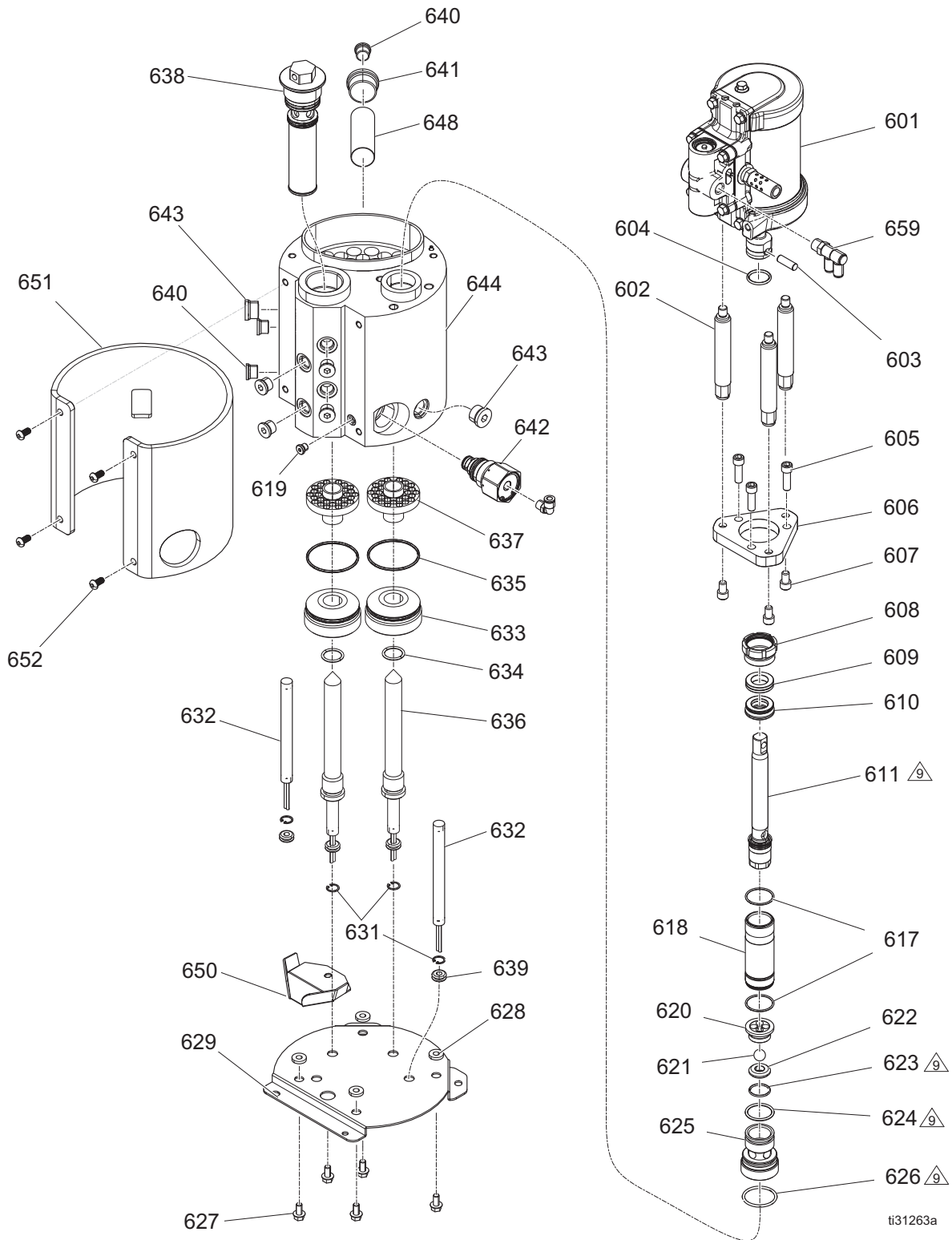

Melter Assembly 17S257 Parts List

Ref.	Part	Description	Qty.	Ref.	Part	Description	Qty.
601	25C160	MOTOR, air, 2.5 in., hi temp, 1.5 strk	1	633†	17M473	PLUG, melter	2
602	16W387	ROD, tie, 1.5 in. stroke	3	634†	558722	O-RING	2
603	196762	PIN, straight	1	635†	102867	PACKING, O-ring	2
604	514129	PACKING, o-ring	1	636†	17M474	HOUSING, firerod	2
605	-----	SCREW, cap, socket head, 5/16-18	3	637	17M476	HEAT SINK, melter	2
606	17M475	PLATE, tie rod	1	638	24P855	FILTER, assy, 100 mesh, welded	1
607	-----	SCREW, cap, sh, 5/16-18	3	639	-----	GROMMET, 1/4 ID	4
608	193046	NUT, packing	1	640	15H304	FITTING, plug 9/16 sae	7
609	17L996	BEARING, throat	1	641	15H305	FITTING, plug hollow hex 1-3/16 sae	1
610	17L995	SEAL, throat	1	642	26A242	VALVE, relief	1
611★	-----	ROD, displacement	1	643	295607	PLUG, hex	2
612★	-----	BALL, .31250	1	644✘	-----	MANIFOLD, melter, HM25c	1
614★	-----	SEAL, u-cup, piston	1	648	17N323	SCREEN, wire	1
615★	-----	BEARING, piston	1	650	17P898	TRAY, drip, HM25c	1
616★	-----	VALVE, piston	1	651	129178	INSULATOR, heat jacket	1
617	108526	PACKING, o-ring, ptfе	2	652	111831	SCREW, cap, skt, button hd	4
618	248209	KIT, repair, sleeve	1	659	129810	FITTING, double union, 1/4 tube	1
619	556431	PLUG, sae, 5/16-24	1				
620	192624	GUIDE, ball	1				
621	105445	BALL, .5000	1				
622	192642	SEAT, carbide	1				
623	107079	PACKING, O-ring	1				
624	105802	O-RING	1				
625	17M477	HOUSING, valve, foot	1				
626	113944	PACKING, O-ring	1				
627	113161	SCREW, flange, hex hd	5				
628	167002	INSULATOR, heat	4				
629	17N255	BRACKET, melter, HM25c, painted	1				
631✘	111317	RING, retaining, int.	4				
632✘	-----	HEATER, fire rod, 1000 watts, 240V	4				
*							

† Included in melter firerod holder kit 25C766.

✘ Available in Melter Manifold Kit 17S258 which includes two heaters (632).

* Heater repair kit 17P347 includes four heaters (632) with electrical leads labeled.

★ Included in displacement rod repair kit 25C513.

△₃ Torque to 27 +/- 3 ft-lb (36.6 +/- 4 N•m).

△₉ Lubricate o-rings.

Accessories

NOTE: For pattern controller accessories, see manual 334784.

Adapter Plate Kit, 25M528

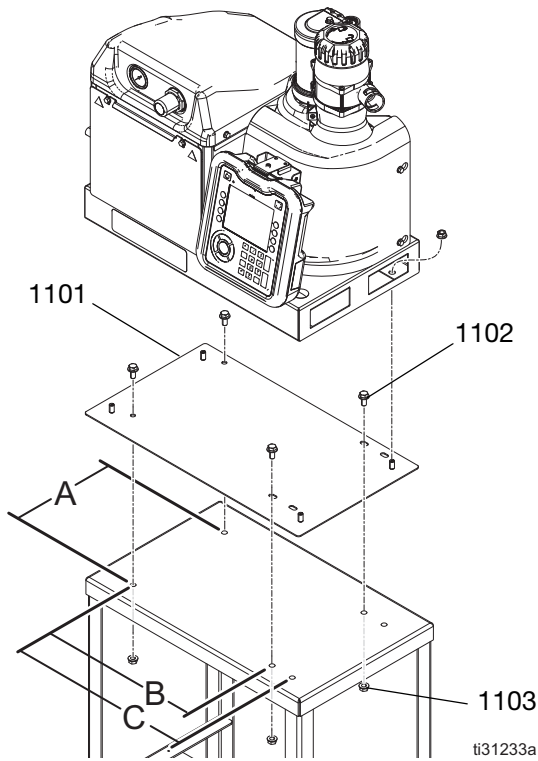

System Stand Kit, 17S264

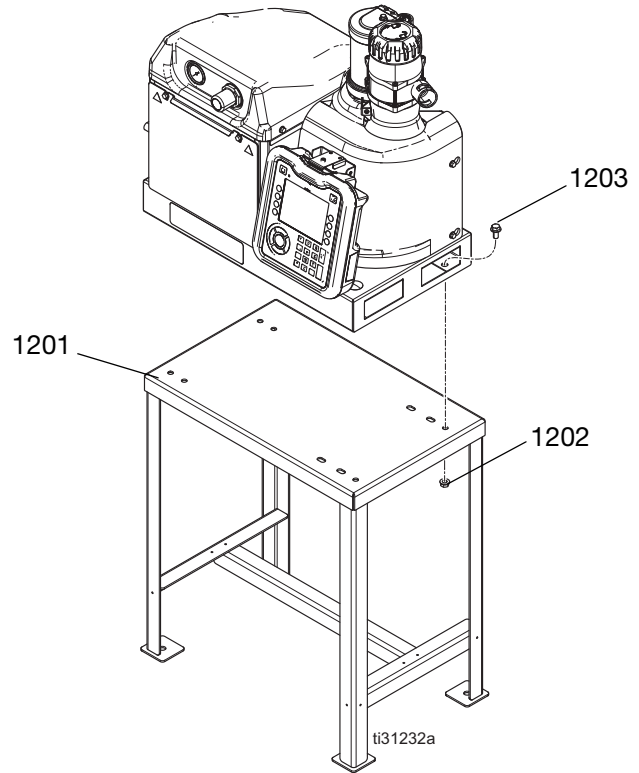

Ref.	Part	Description	Qty
1101	-----	PLATE, adapter, HM25c, painted	1
1102	112395	SCREW, cap, flanged hd	4
1103	112958	NUT, hex, flanged	8

Ref.	Part	Description	Qty
1201	-----	STAND, InvisiPac, HM25c, painted	1
1202	112958	NUT, hex, flanged	4
1203	112395	SCREW, cap, flanged hd	4

Light Tower Kit, 25C662

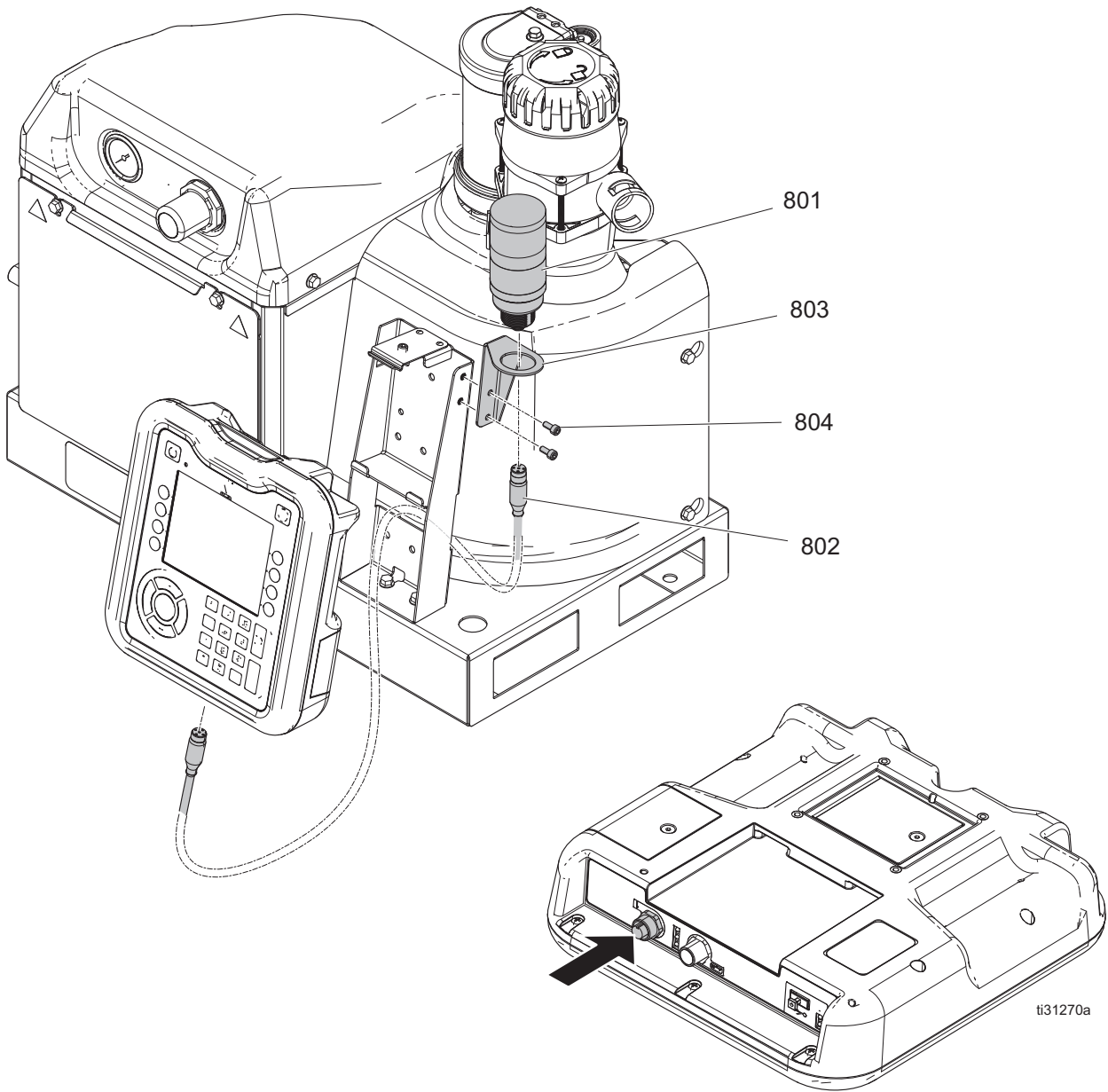

Ref.	Part	Description	Qty
801	127087	LIGHT, tower, 30 mm, red/green	1
802	17R703	CABLE, GCA, M12-5P, m/f, 0.3 m	1
803	-----	BRACKET, light tower, painted	1
804	-----	SCREW, shcs M5 x 12	2

HM25C Melter Guard Kit, 25D461

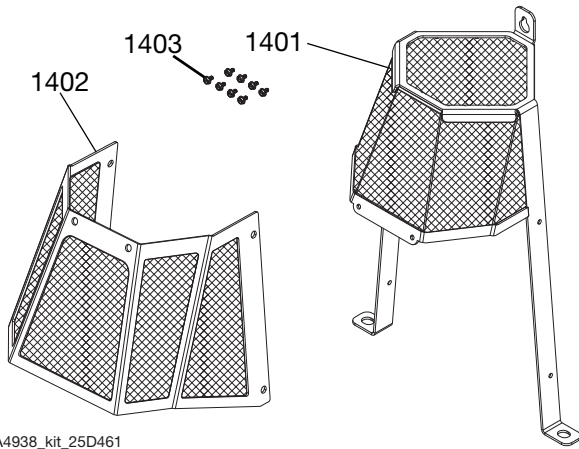

3A4938_kit_25D461

HM25C Melter Guard Kit 25D461 Parts List

Ref.	Part	Description	Qty.
1401	----	GUARD, frame, HM25C melter	1
1402	----	GUARD, shield, HM25C, melter	1
1403*	----	SCREW, #6, 0.25, hex, thd cutting	8

* One extra screw (1403) is included in the kit.

Installation

1. Remove two flange head hex nuts (30) as shown from the HM25C melter shroud bracket (21) and set aside for reuse.

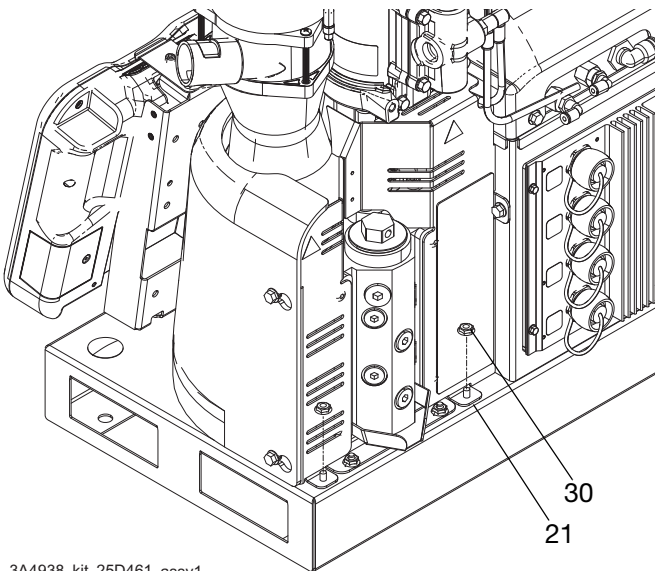

3A4938_kit_25D461_assy1

2. Place HM25C guard frame legs onto the HM25C system base (301) studs and replace, but do not tighten the flange head hex nuts (30) onto the studs. Put 0.25 thread cutting screw (1403) through the top hole of the HM25C guard frame (1401) and thread into the HM25C melter shroud bracket (21). Tighten the flange hex nuts (30) and 0.25 thread cutting screw.
3. Line up the holes of the HM25C guard shield (1402) with the HM25C guard frame (1401). Thread the 0.25 thread cutting screws (1403) into the holes and tighten.

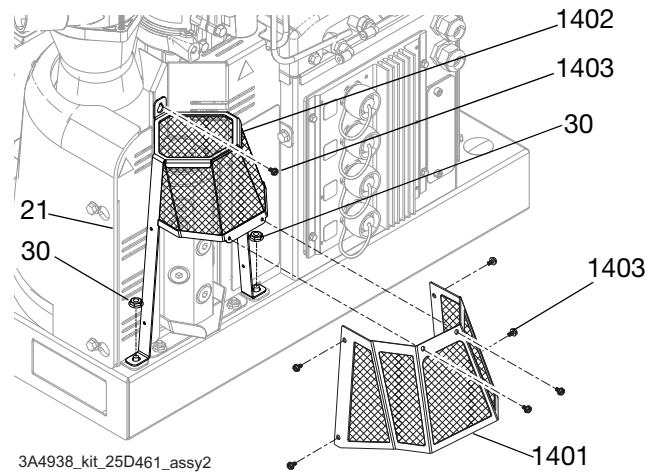

3A4938_kit_25D461_assy2

Fluid Port Connectors Kit 24V504

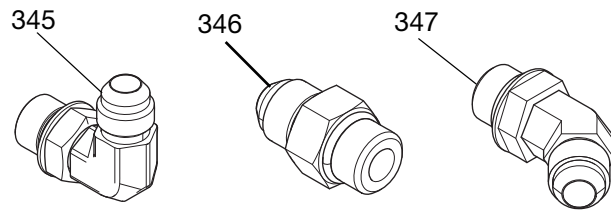

3A4938_kit_24V504

Fluid Port Connectors Kit 24V504 Parts List

Ref.	Part	Description	Qty.
345	----	90° SWIVEL ELBOW FITTING, JIC 06, FM, MS	6
346	----	ADAPTER FITTING, JIC, 06, X, SAE, 06, mm, cs	6
347	----	45° SWIVEL ELBOW FITTING, MxF, JIC-6	6

ADM Remote Mount Extension Cables

Used to connect a remote mounted ADM to an InvisiPac system.

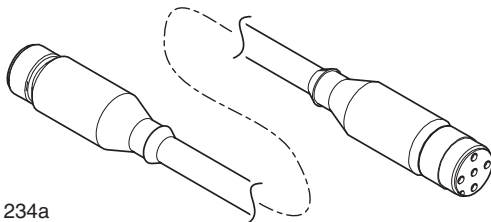
Part	Description	Image
24R710	5M CAN Extension Cable	 <p>ti31234a</p>
24R711	15M CAN Extension Cable	

Material Tracking Kit

Used to track material consumption per product without a pattern controller.

Installation

1. See **Connect Material Tracking Input** (page 19) for details on hardware installation.
2. Navigate to the Material Tracking Setup screen (see **System Screen 4 - Material Tracking Setup**, page 88) and check “Enable AUX Counter” setting.
3. Navigate to the **Material Log** screen using the softkey on the Home screen (see page 82). Verify sensor counts once per product.

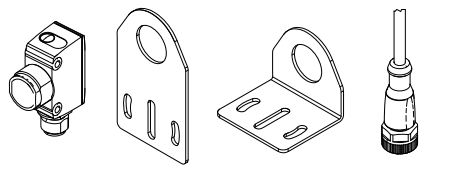
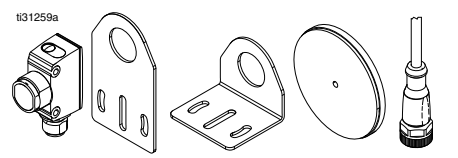
Part	Description	Contents	Image
24X446	KIT, photoeye, diffuse, 18 mm	128073 - SENSOR, photoelectric diffuse 128071 - BRACKET, sensor mount, straight 128070 - BRACKET, sensor mount, angled 24X449 - CABLE, M12, 4-pin, 5.0 m	 <p>ti31235a</p>
24X447	KIT, photoeye, pol ret ref, 18 mm	128072 - SENSOR, photoelectric, polarized 128071 - BRACKET, sensor mount, straight 128070 - BRACKET, sensor mount, angled 128069 - SENSOR, reflector 24X449 - CABLE, M12, 4-pin, 5.0 m	 <p>ti31259a</p>

Hose Adapters

Used to connect non-Graco hoses to an InvisiPac system.

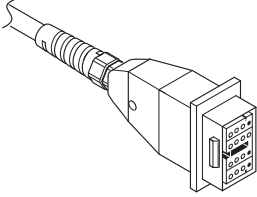
Part	Description	Image
128621	For connecting to non-Graco hoses that use a NI 120 RTD.	 <p style="text-align: right; font-size: small;">ti30742a</p>

Applicator Adapters

Used to connect non-Graco applicators to Graco heated hoses.

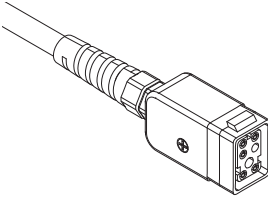
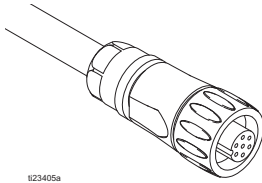
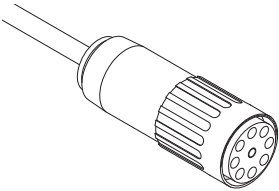
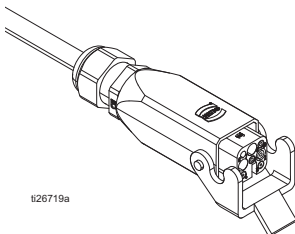
Part	Description	Image
16T916	For connecting to non-Graco applicators that use a rectangular, 6-pin connector.	
16Y828	For connecting to non-Graco applicators that use a circular, 6-pin connector. IPx6 rated.	 <p style="text-align: center; font-size: x-small;">ti23405a</p>
16T917	For connecting to non-Graco applicators that use a circular, 9-pin connector.	
128372	For connecting to non-Graco applicators that use a rectangular, 8-pin connector.	 <p style="text-align: center; font-size: x-small;">ti26719a</p>

Upgrade Kits

DANGER

DANGER
SEVERE ELECTRIC SHOCK HAZARD
 This equipment can be powered by more than 240V. Contact with this voltage will cause death or serious injury.

- Turn off and disconnect power at main switch before disconnecting any cables and before servicing equipment.
- This equipment must be grounded. Connect only to grounded power source.
- All electrical wiring must be done by a qualified electrician and comply with all local codes and regulations.



8 Channel Upgrade Kit, 25M527

Installation

1. Turn main power switch (H) OFF and disconnect power from the system.
2. Remove blank plate (AA) and replace with AMZ #2 (1409)
3. Replace 4-channel AMZ power harness with 8-channel harness (1402).
4. Install caps (1405) on connectors.

5. Set AMZ #2 (1409) rotary switch to "2".
6. Connect CAN cable (1403) between AMZ 1 and AMZ 2.

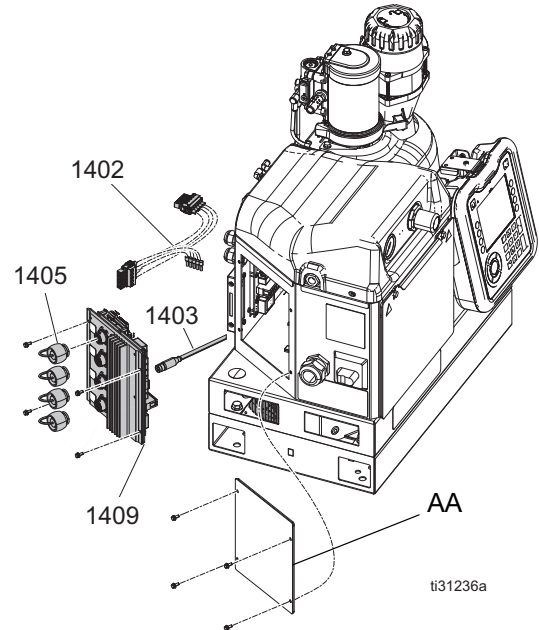

Ref.	Part	Description	Qty
1402	17M491	HARNESS, disconnect, 8 ch	1
1403	121000	CABLE, can, female/female 0.5 m	1
1405	16T440	CAP, souriau, UTS14	4
1409	25M525	KIT, repair, AMZ	1

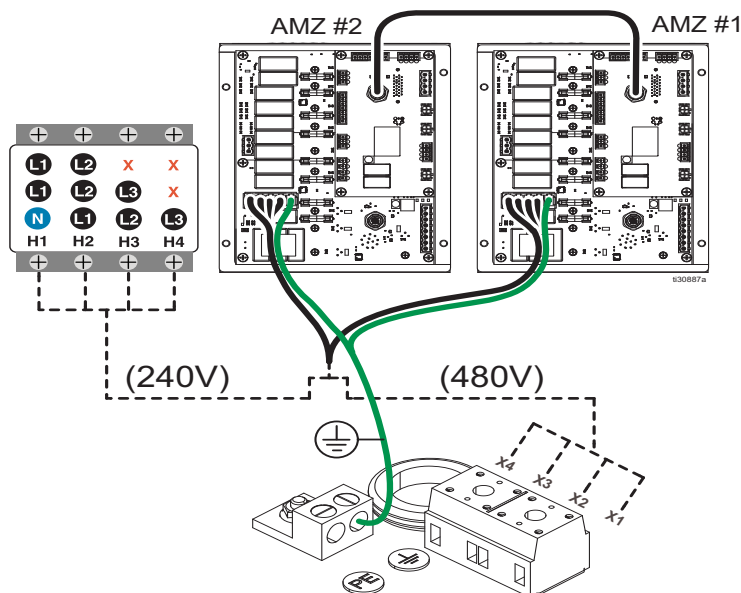

PC-8 Upgrade Kit, 25M526

Used to upgrade a system and add pattern control (PC-8).

NOTE: To upgrade to PC-8e, order kit 17F712 in addition to the kit listed above.

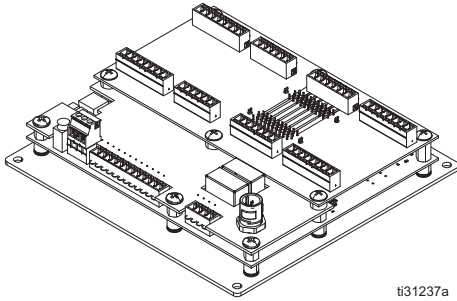

Installation

1. Turn main power switch (H) OFF and disconnect power from the system.
2. Set PCM rotary switch to "0".
3. Mount pattern controller board to bottom of electrical enclosure.
4. Connect power supply harness from AMZ 1 - J3 to PCM - P1.
5. **4-channel systems:** Connect CAN cable between AMZ 1 - J12 and PCM - P3.

8-channel systems: Connect CAN cable between AMZ 2 - J23 and PCM - P3.

Black Disconnect Handle Kit, 17S164

Used to replace a red disconnect handle with a black disconnect handle.

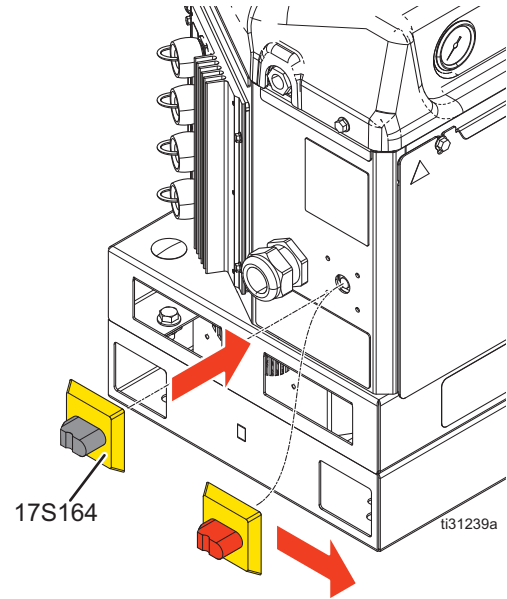

480V Transformer Upgrade Kit, 17S265

Used to upgrade to a 240 VAC system for 480 VAC incoming power.

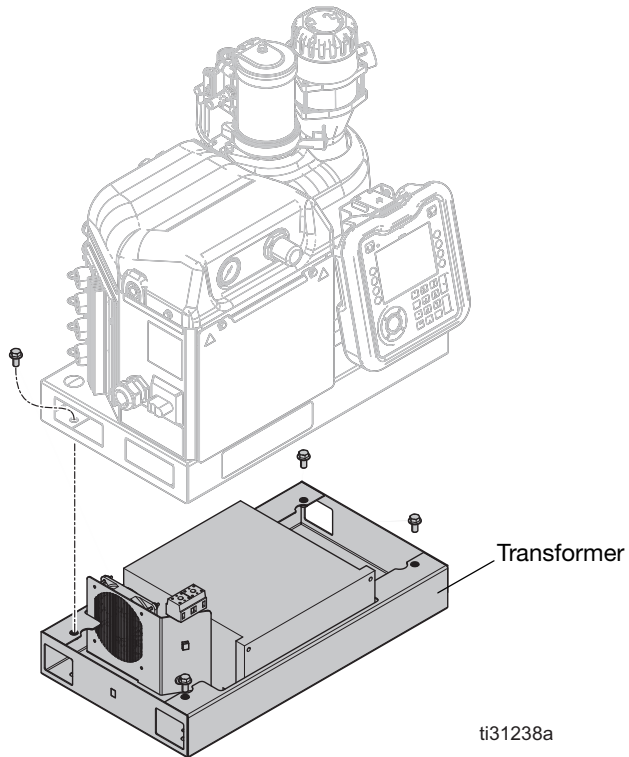

Installation

1. Turn the main power switch (H) OFF and disconnect power from the system.
2. Remove the electrical enclosure door (332).
3. Remove the knockout (KO) on the bottom of electrical enclosure (B).
4. Insert grommet (329) into the knockout hole.
5. Mount terminal block (323) to the bottom of the electrical enclosure using the terminal block mounting screws (327).
6. Disconnect wire harness (308) from disconnect switch (75).
7. Connect wire harness (308) to the back side of terminal block (323). See **Electrical Schematics** on page 54 for details.
8. Route wires from transformer base (325) through the knockout hole.
9. Connect the fan connector to AMZ #1 - J2.
10. Connect free wires labeled H1-H3 to the disconnect switch (75). See **Electrical Schematics** on page 54 for details.
11. Connect free wires labeled X1-X3 to the terminal block (323). See **Electrical Schematics** on page 54 for details.
12. Replace electrical enclosure door (332).

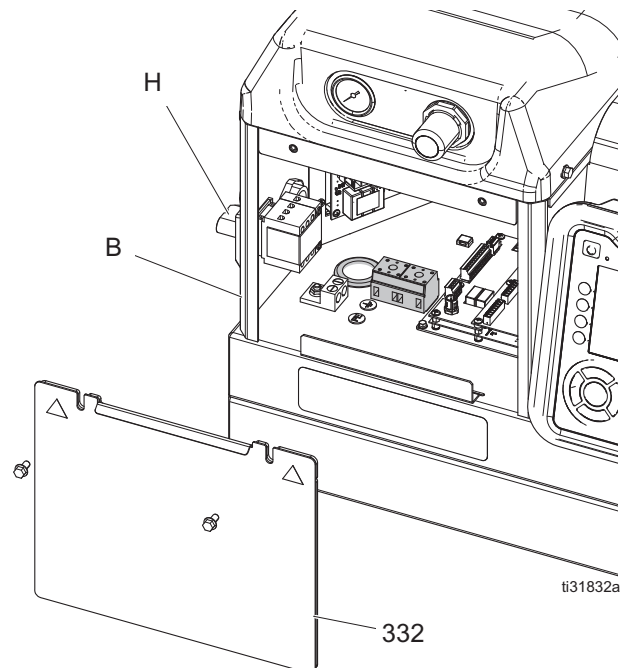
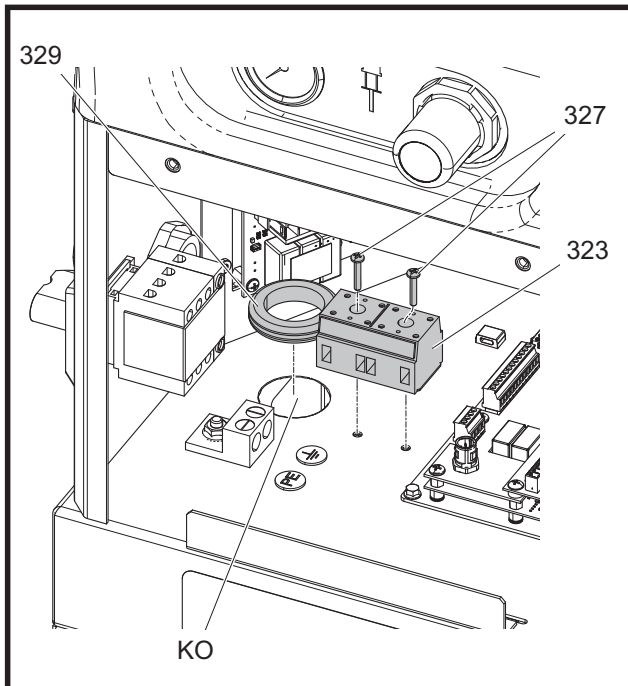

Special Tools

These special tools are designed to make system repairs as easy as possible while ensuring that parts do not get damaged.

Part	Purpose
129804	Spanner wrench to remove melter heater rod housing
1301*	Remove Cylinder
1302*	Install Cylinder - Female
1303*	Install Cylinder - Male

* Parts included in Cylinder Tools Kit 24R227 (purchase separately).

Part	Purpose
1304**	Install Rod - Female
1305**	Install Rod - Male
1306**	Install Rod - Bullet

**Parts included in Rod Tools Kit 24R228 (purchase separately).

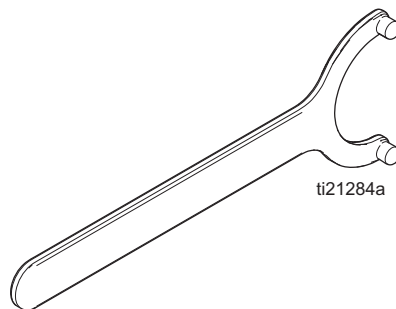
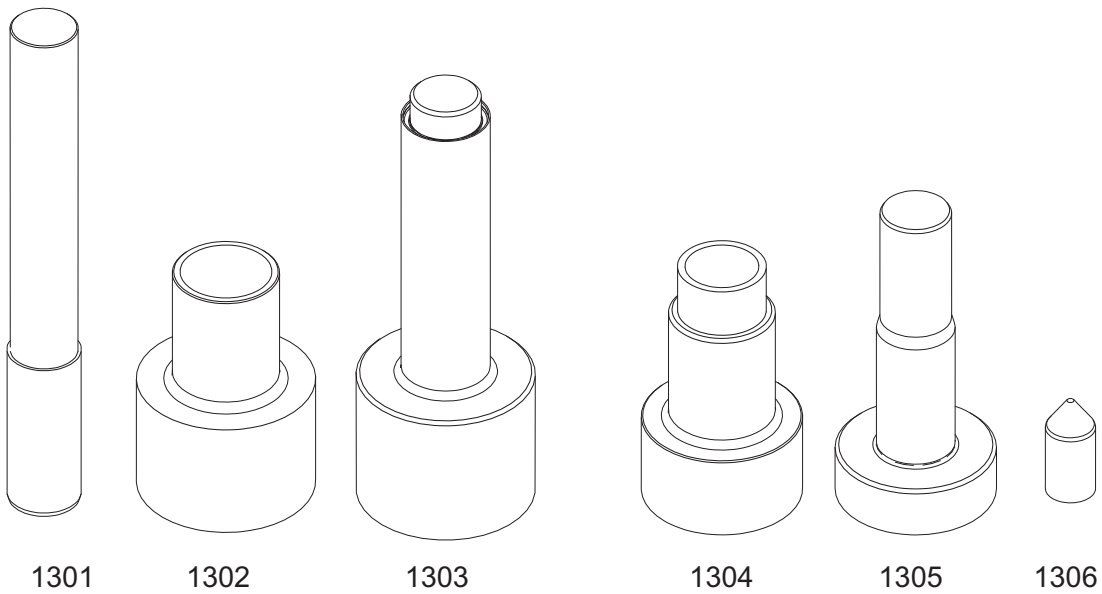

Spanning Wrench - 129804

Air Reservoir Kit, 16W366

Allows the system to operate on lower pressure or restricted air supply lines.

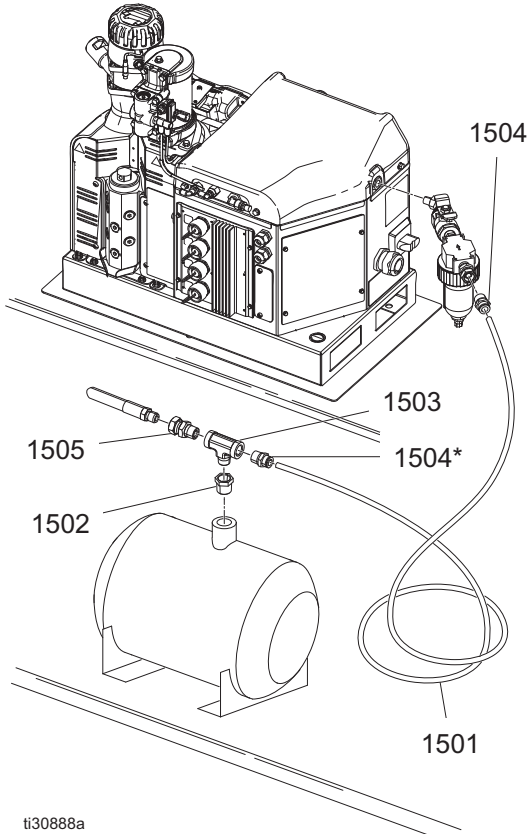

Air Reservoir Kit, 16W366 Parts

Ref.	Part	Description	Qty.
1501	-----	HOSE, nylon (6 ft)	1
1502	1000081	BUSHING, pipe	1
1503	113777	TEE, pipe	1
1504	114485	CONNECTOR, male, 3/8 npt	2
1505	155665	UNION, adapter	1
1506	-----	TANK, air, accumulator	1

CGM Interface Kits

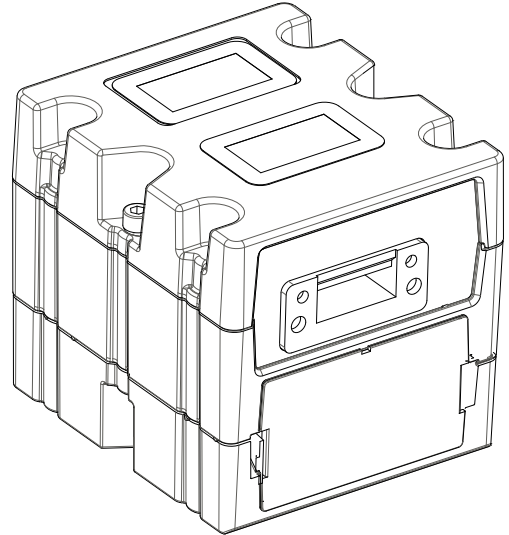

CGM, Module Kit Options

NOTE: This kit requires the purchase of one of the following CGM modules:

Ref.	Part	Description	Qty.
1601	CGMDN0	MODULE, CGA, gateway, DN (Devicenet)	1
1602	CGMEP0	MODULE, CGA, gateway, EP (EitherNet/IP)	1
1603	CGMPB0	MODULE, CGA, gateway, PB (Profibus)	1
1604	CGMPN0	MODULE, CGA, gateway, PN (Profinet)	1

Appendix A - ADM (Advanced Display Module)

ADM Interface

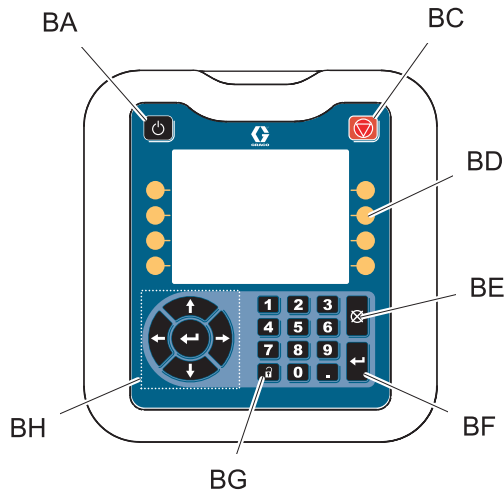

Key	Function
BA	System Enable/Disable
BC	Stop all system processes
BD	Defined by icon next to soft key
BE	Abort current operation
BF	Accept change, acknowledge error, select item, toggle selected item
BG	Toggle between Run and Setup screens
BH	Navigate within a screen or to a new screen

Screen Navigation

Navigate through each screen to set up and operate the InvisiPac HM25c.

NOTE: additional screens are present for the pattern controller on InvisiPac systems with an integrated pattern controller. Refer to **InvisiPac Pattern Controller** manual for details.

Run Screens

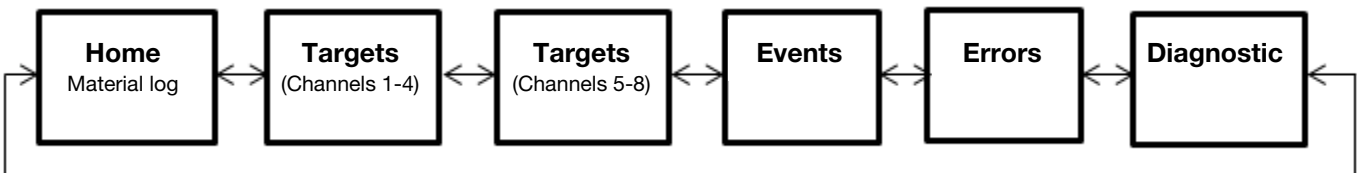

Press the unlock key  to switch between Run and Setup screens.

Setup Screens

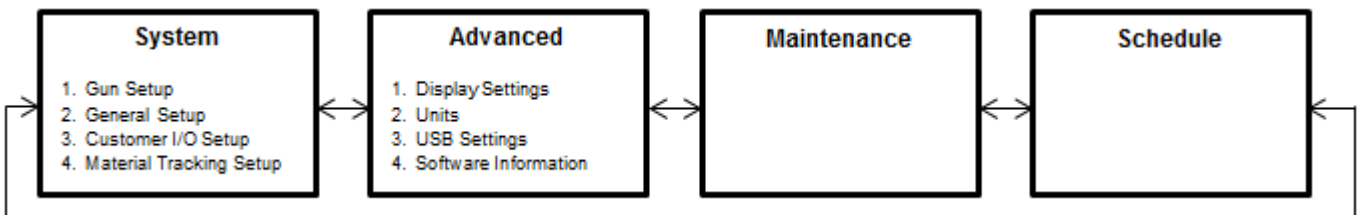

ADM Screens

Home

Read-only view of system heat states and temperatures.

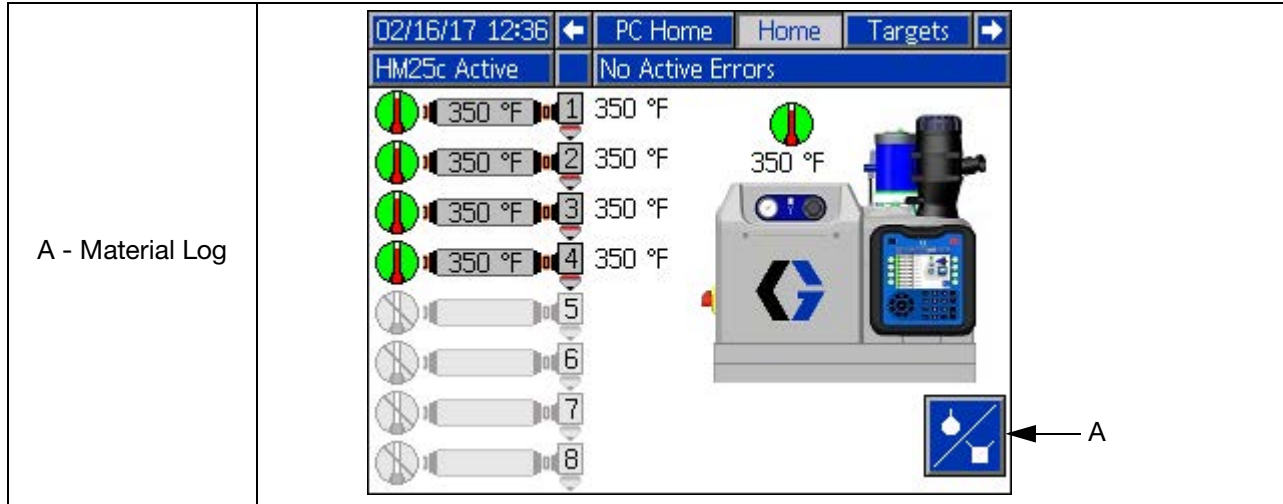

Icon	Name	Description
	Channel Heat state	Channel heat state: Active Warmup Inactive Not Installed
	Hose Temperature	Current temperature of the hose
	Gun (Applicator) Temperature	Current temperature of the gun
	Melter Heat State and Temperature	Current temperature of the melter and melter heat state: Active Warmup Inactive Not Installed NOTE: Melter heat state is not ACTIVE until all installed channels and the melter have reached setpoint.
	Material Log Softkey	Use to navigate to the Material Log screen.

Material Log

View of material log.

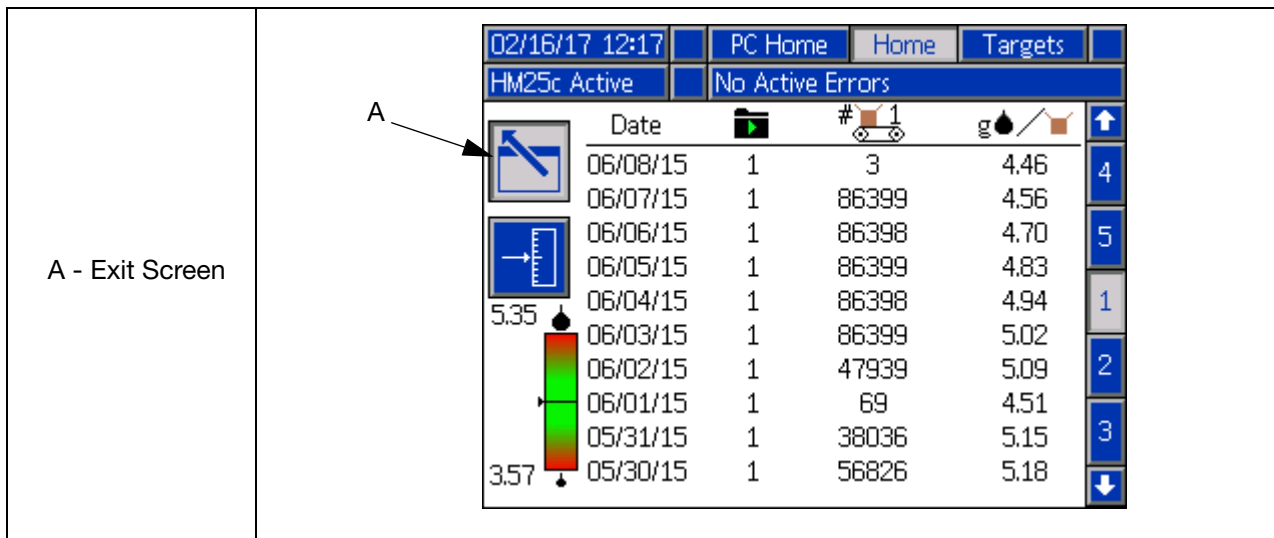

Icon	Name	Description
	Reset Material Target	Press to reset the target material per unit to the current value. An hourglass will appear in place of the material usage scale in the bottom left corner until a new target value is learned.
	Material Usage Scale	Indicates current material per unit relative to the learned target value. The current material per unit is denoted by the arrow indicator and black blinking bar. The top of the scale indicates high usage of 20% deviation above target. The bottom of the scale indicates low usage of 20% deviation below the target. If material alerts are enabled, an alert will be generated each time the current value goes outside the range shown (see System Screen 4 - Material Tracking for details).
Date	Date	Date of the material log entry.
Cycles	Cycles	Total pump cycles.
lb	Material Used	Total material used.
	Program	Pattern controller program.
#	Product Count	Total products produced. # 1 Products on pattern controller line 1. # 2 Products on pattern controller line 2. 12345 Products on non-pattern controller systems.
g	Material Per Product	Average material per product.

NOTE: Not all material log columns are present on all systems.

Targets

View and adjust system temperature setpoints.

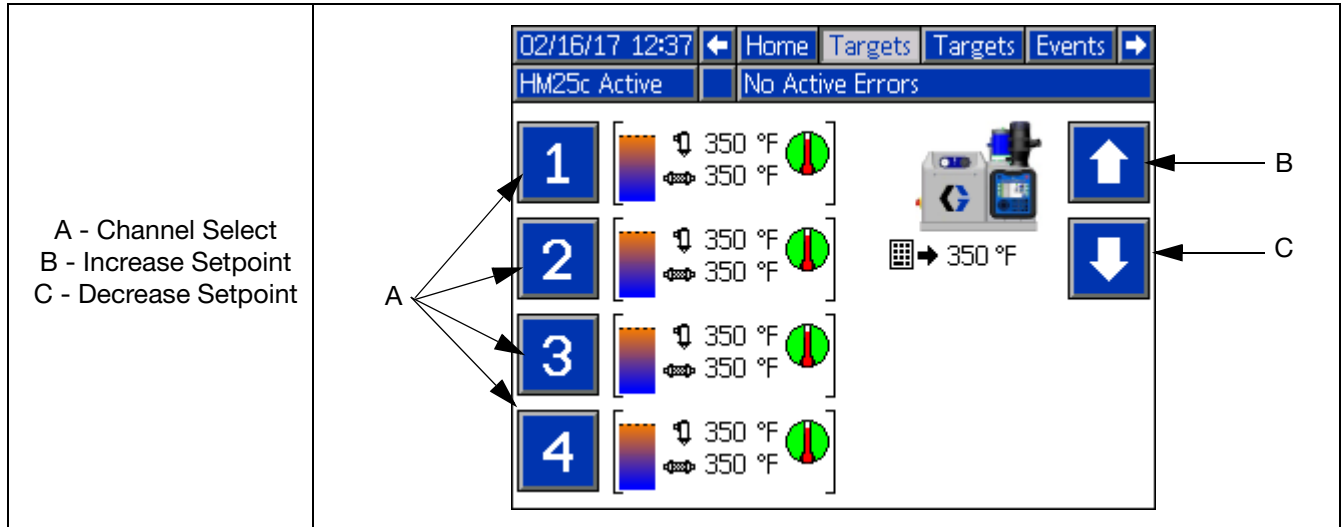

A - Channel Select
 B - Increase Setpoint
 C - Decrease Setpoint

Icon	Name	Description
	Number Pad Indicator	Indicates which setting will be changed when using the ADM number keypad.
	Channel Select	Press softkey to select channel and enter setpoints for gun and hose. NOTE: a second Targets screen is available for eight channel systems. Press the right arrow key to navigate to the second screen. NOTE: press and hold softkey to copy the melter temperature setpoint to the channel temperature setpoint (for faster setup).
	Increase Setpoint	Press softkey to increase temperature setpoint.
	Decrease Setpoint	Press softkey to decrease temperature setpoint.

Errors

Read-only view of logged errors. Press the up and down arrows to scroll through the log.

02/16/17 12:08				←	Events	Errors	Diagnostic	→	
HM25c Inactive		No Active Errors							
Date	Time	Code	Description						
02/16/17	12:08	L6FX	Level Sensor Error						
02/16/17	12:07	CACP	Comm. Error PCM						
				1					

Events

Read-only view of logged events. Press the up and down arrows to scroll through the log.

02/16/17 12:06				←	Targets	Events	Errors	→	
HM25c Inactive		No Active Errors							
Date	Time	Code	Description						
02/16/17	12:06	ERM1	Material Target Reset	6					
02/16/17	12:06	ECOP	Setup Value(s) Changed	7					
02/16/17	12:05	EQU1	Sys. Settings Downloaded	8					
02/16/17	12:05	EQU3	Custom Lang. Downloaded	1					
02/16/17	12:05	EQU5	Logs Downloaded	2					
02/16/17	12:04	EBUX	USB Drive Removed	3					
02/16/17	12:04	EQU1	Sys. Settings Downloaded	4					
02/16/17	12:04	EQU3	Custom Lang. Downloaded	↓					
02/16/17	12:04	EQU5	Logs Downloaded						
02/16/17	12:03	ELOX	System Power On						

Diagnostic

Read-only view of the important system diagnostic information.

02/16/17 12:16 Errors Diagnostic PC Control

HM25c Active No Active Errors

A

●	350.0 °F	8.0 A	10 %
●	350.0 °F	8.0 A	10 %
↓	350.0 °F	1.5 A	10 %
↔	350.0 °F	1.0 A	10 %
↓	350.0 °F	1.5 A	10 %
↔	350.0 °F	1.0 A	10 %
↓	350.0 °F	1.5 A	10 %
↔	350.0 °F	1.0 A	10 %
↓	350.0 °F	1.5 A	10 %
↔	350.0 °F	1.0 A	10 %
↓	70.0 °F	0.0 A	0 %
↔	70.0 °F	0.0 A	0 %
↓	70.0 °F	0.0 A	0 %
↔	70.0 °F	0.0 A	0 %
↓	70.0 °F	0.0 A	0 %
↔	70.0 °F	0.0 A	0 %
↓	70.0 °F	0.0 A	0 %
↔	70.0 °F	0.0 A	0 %

B 10.0 CPM
20.0 lb/h
5400 s

C Fill 4.000 V
9000 ms
10 Cycles
10 %

E PLC Inputs

D

F PLC Outputs

G USB Download 0 %

H 90.0 °F

J

Line	AMZ 1	AMZ 2
1	240 V	240 V
2	240 V	240 V
3	240 V	240 V

Legend:
 A - Heat Zones
 B - Pump
 C - Fill (Feed System)
 D - AUX Unit Counter
 E - PLC Inputs
 F - PLC Outputs
 G - USB Download %
 H - Transformer
 J - Line Voltage

NOTE: Use the up and down arrow keys to scroll up and down within the screen.

System Screen 1 - Gun Setup

Install heat channels and select gun RTD type.

02/16/17 12:08 PC Setup System Advanced

HM25c Inactive No Active Errors

A → [Enter/Exit Icon]

Gun (Applicator) Number	Installed	Gun Current Temperature	Gun RTD Type
1	<input checked="" type="checkbox"/>	75 °F	Pt, 100Ω/1000Ω
2	<input checked="" type="checkbox"/>	75 °F	Pt, 100Ω/1000Ω
3	<input checked="" type="checkbox"/>	75 °F	Ni, 120Ω
4	<input checked="" type="checkbox"/>	75 °F	Ni, 120Ω
5	<input type="checkbox"/>	--- °F	Pt, 100Ω/1000Ω
6	<input type="checkbox"/>	--- °F	Pt, 100Ω/1000Ω
7	<input type="checkbox"/>	--- °F	Pt, 100Ω/1000Ω
8	<input type="checkbox"/>	--- °F	Pt, 100Ω/1000Ω

B → [Screen Number 1]

Legend:
 A - Enter/Exit Screen
 B - Screen Number

Icon	Name	Description
	Gun (Applicator) Number	Number of each gun that the row applies to.
<input checked="" type="checkbox"/> / <input type="checkbox"/>	Installed	Check to install a channel (gun and hose pair).
75 °F	Gun Current Temperature	Current temperature of the gun (according to the RTD type selected).
Pt, 100Ω/1000Ω ▾	Gun RTD Type	Drop-down selection of gun RTD type. Select gun RTD type according to documentation supplied with each gun.

System Screen 2 - General Setup

Install heat channels and select gun RTD type.

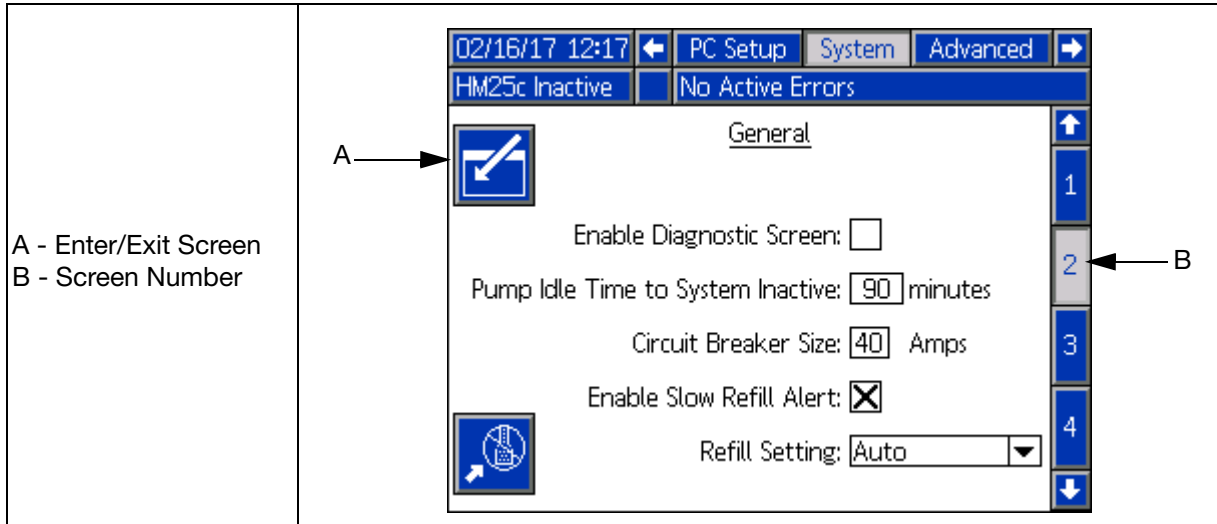

A - Enter/Exit Screen
B - Screen Number

Icon	Name	Description
<input checked="" type="checkbox"/> / <input type="checkbox"/>	Enable Diagnostic Screen	Check to enable Diagnostic screen in Run screens. See Diagnostic screen for details.
<input type="text" value="60"/> minutes	Pump Idle Time to System Inactive	Set to allow the system to automatically go to the Inactive state after the desired duration of pump inactivity.
<input type="text" value="40"/> Amps	Circuit Breaker Size	Select the circuit breaker size used. Use the size of the circuit breaker used to supply power to the system (circuit breaker is external to the system).
<input checked="" type="checkbox"/> / <input type="checkbox"/>	Enable Slow Refill Alert	Check to enable the slow refill alert (Error code "L3FX"). See Troubleshooting section for details.
<input type="text" value="Auto"/> ▼	Refill Setting	Drop-down selection with the following options: <ul style="list-style-type: none"> Auto: the fill mode that provides a constant pulse. Use automatic feed system. See Automatic Refill section for details. Manual: do not use automatic feed system. See Manual Refill section for details. Auto-Adapting: changes the pulse based on the previous fill to keep the fill around to five seconds.
	Refill Setting Softkey	Press softkey to toggle Refill Setting between Auto and Manual.

System Screen 3 - PLC I/O Setup

Configure and view the current state of the system PLC inputs and outputs.

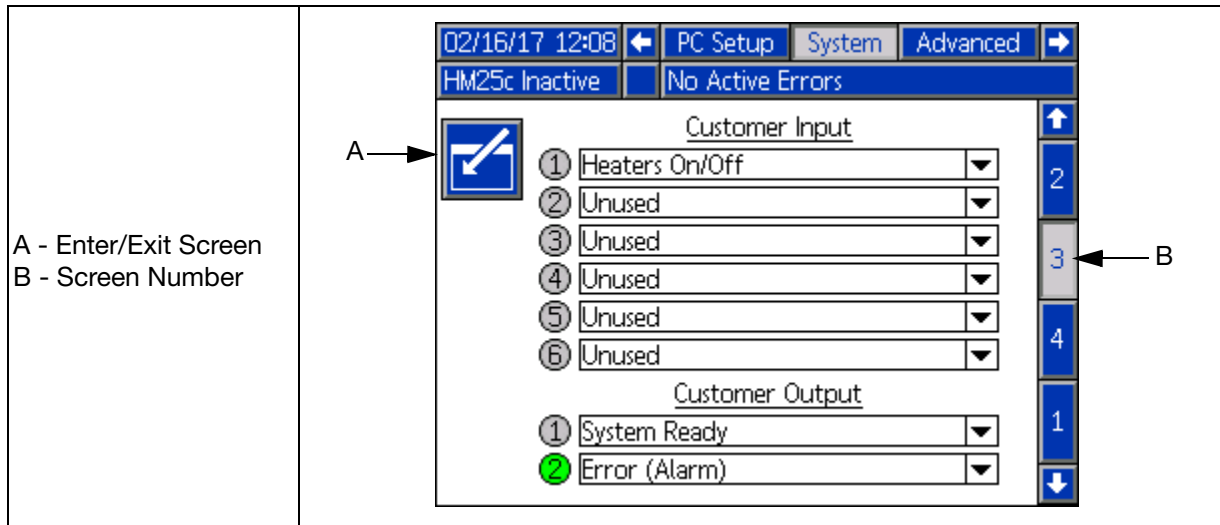

A - Enter/Exit Screen
B - Screen Number

Icon	Name	Description												
	Signal State Indicator	Indicates the current state of the input/output signal (see tables below) <div style="display: flex; justify-content: space-around;"> <div style="text-align: center;"> Inputs: Voltage Present </div> <div style="text-align: center;"> Voltage Absent </div> </div> <div style="display: flex; justify-content: space-around; margin-top: 5px;"> <div style="text-align: center;"> Outputs: Contact Closed </div> <div style="text-align: center;"> Contact Open </div> </div>												
	Input Option	Drop-down selection of the desired input option. Available options are outlined in the table below. All input options except Pump Enable/Disable are transition-based. <table border="1" style="width: 100%; margin-top: 10px;"> <thead> <tr> <th>Option</th> <th>Action</th> </tr> </thead> <tbody> <tr> <td>Unused</td> <td>Input disabled.</td> </tr> <tr> <td>Heaters On/Off</td> <td>Turn system ON and OFF.</td> </tr> <tr> <td>Pump Enable/Disable</td> <td>Enable or disable pump. NOTE: pump will remain disabled if the input signal is in the disabled state (voltage absent).</td> </tr> <tr> <td>Channel X Enable/Disable</td> <td>Enable or disable channel X.</td> </tr> </tbody> </table>	Option	Action	Unused	Input disabled.	Heaters On/Off	Turn system ON and OFF.	Pump Enable/Disable	Enable or disable pump. NOTE: pump will remain disabled if the input signal is in the disabled state (voltage absent).	Channel X Enable/Disable	Enable or disable channel X.		
Option	Action													
Unused	Input disabled.													
Heaters On/Off	Turn system ON and OFF.													
Pump Enable/Disable	Enable or disable pump. NOTE: pump will remain disabled if the input signal is in the disabled state (voltage absent).													
Channel X Enable/Disable	Enable or disable channel X.													
	Output Option	Drop-down selection of the desired output option. Available options are outlined in the table below. All output options are normally open when power is OFF. <table border="1" style="width: 100%; margin-top: 10px;"> <thead> <tr> <th>Option</th> <th>Action</th> </tr> </thead> <tbody> <tr> <td>Unused</td> <td>Output disabled.</td> </tr> <tr> <td>System Ready</td> <td>Close contact when system is ready.</td> </tr> <tr> <td>Error (Alarm)</td> <td>Open contact when alarm is present. NOTE: alarms disable the system heat and pump.</td> </tr> <tr> <td>Error (Deviation/Advisory)</td> <td>Close contact when deviation/advisory is present. NOTE: deviations and advisories do not disable the system heat and pump.</td> </tr> <tr> <td>Maintenance Due</td> <td>Close contact when selected maintenance interval is reached. NOTE: see Maintenance screen for details on maintenance interval setup.</td> </tr> </tbody> </table>	Option	Action	Unused	Output disabled.	System Ready	Close contact when system is ready.	Error (Alarm)	Open contact when alarm is present. NOTE: alarms disable the system heat and pump.	Error (Deviation/Advisory)	Close contact when deviation/advisory is present. NOTE: deviations and advisories do not disable the system heat and pump.	Maintenance Due	Close contact when selected maintenance interval is reached. NOTE: see Maintenance screen for details on maintenance interval setup.
Option	Action													
Unused	Output disabled.													
System Ready	Close contact when system is ready.													
Error (Alarm)	Open contact when alarm is present. NOTE: alarms disable the system heat and pump.													
Error (Deviation/Advisory)	Close contact when deviation/advisory is present. NOTE: deviations and advisories do not disable the system heat and pump.													
Maintenance Due	Close contact when selected maintenance interval is reached. NOTE: see Maintenance screen for details on maintenance interval setup.													

NOTE: See the Setup section for details on PLC I/O wiring.

System Screen 4 - Material Tracking Setup

Setup material tracking settings.

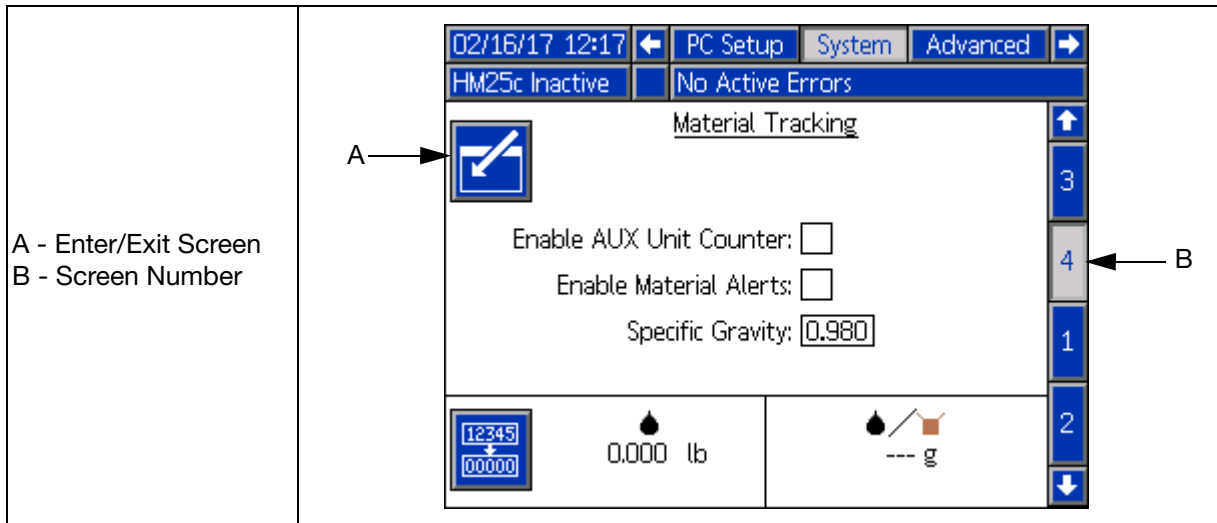

A - Enter/Exit Screen
B - Screen Number

Icon	Name	Description
	Calibration Weight Totalizer	Resettable totalizer that can be used for determining Specific Gravity.
	Material per Unit	Current material per unit.
	Reset Weight Totalizer	Press softkey to reset the calibration weight totalizer.
	Enable AUX Unit Counter	Check to enable the AUX unit counter on the System IO Board. See Setup section for AUX Unit Counter wiring details. NOTE: this box does not need to be checked for systems with an integrated pattern controller.
	Enable Material Alerts	Check to enable material alerts when the current material unit deviates 20% from the established target. See Material Log screen for details on setting a target material per unit.
	Specific Gravity	Specific Gravity of the material in use. See Calibration section for methods to determine the appropriate value.

Advanced Screen 1 - Display Settings

General display settings including language, time and password protection.

Name	Description
Language	Select the display language.
Date Format	Select the display date format.
Date	Enter the display date.
Time	Enter the display time.
Password	Enter the password to restrict access to the Setup screens. NOTE: a value of "0000" does not require a password for access to Setup screens.
Screen Saver	Enter the timeout for the display screen saver. NOTE: a value of "0" disables the screen saver.
Silent Mode	Check to disable display beep functionality.
Lock Run Screens	If checked, operators will not be able to change most run screen settings. NOTE: in order for this setting to take effect, a password other than "0000" must be entered above. NOTE: when returning to the Run screens from the setup screens, the operator will have two minutes to make changes before the screens lock.

Advanced Screen 2 - Units

Select the system units to be used on the display.

Name	Description
Temperature Units	Select the system temperature units.
Mass Units	Select the system mass units.
Distance Units	Select the system distance units. NOTE: this setting only applies to pattern controller values.

Advanced Screen 3 - USB Settings

Select USB download settings.

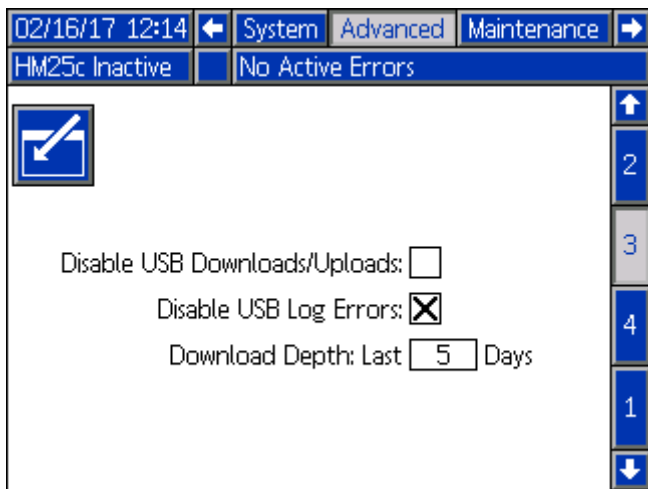

Name	Description
Disable USB Downloads/Uploads	Disables USB port from transmitting data to/from a USB drive.
Disable USB Log Errors	Disables USB log advisories.
Download Depth	Sets the length of the data logs to be downloaded (affects the download time).

Advanced Screen 4 - System Software

Read only display of system software.

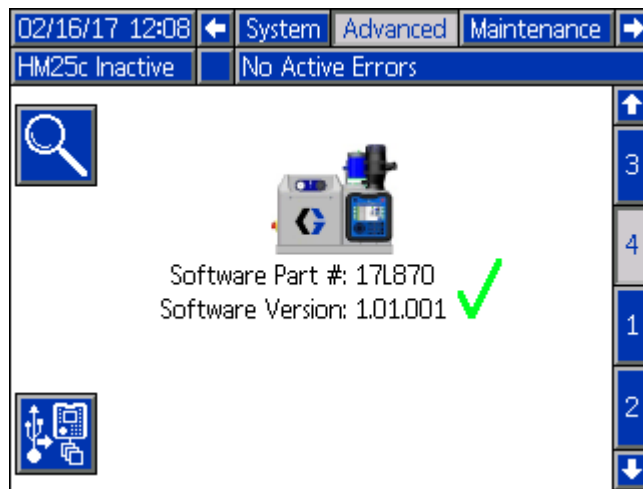

Name	Description
System Software Part #	Part number of the software on the most recently loaded system software token. NOTE: this part number is not the part number of the system software token (PN 17R827).
System Software Version	Version of the software on the most recently loaded system software token.



NOTE: A red X next to the software means that one or more system components have software that is not the current version. This will not prevent the system from running. All components can be updated to run the current software version by performing the **Software Update Procedure** on page 96.

Maintenance

Setup material tracking settings.

02/16/17 12:08
Maintenance
Schedule

HM25c Inactive
No Active Errors

A - Enter/Exit Screen

A → 

	Current	Interval	Lifetime	
Pump	38	0	14658	cycles
	<input type="text" value="0"/>	<input type="text" value="0"/>	529	lb
Heat On	<input type="text" value="0"/>	<input type="text" value="0"/>	6580	hours
Pump Idle	<input type="text" value="0"/>	<input type="text" value="0"/>	3868	hours



Name	Description
Current	Resettable counter for the variable in the row. NOTE: to reset to zero and clear an existing advisory, select the counter and press the reset softkey in the bottom left corner. 
Interval	Maintenance interval period for variable in the row. NOTE: set to a non-zero value to generate advisories when the current counter reaches this value.
Lifetime	Lifetime counter of the variable in the row.
Pump Cycles	Pump cycle totalizers.
Pump Weight	Pump weight totalizers.
Heat On Time	Heat on time totalizers (time spent with heat on).
Pump Idle Time	Pump idle time totalizer (time spent with system at temperature, but no pump activity).

Schedule

Set daily system ON and OFF commands following a weekly schedule.

A - Enter/Exit Screen

Icon	Name	Description
	Schedule Entry	The time value (24-hour clock) of the schedule entry indicates the time that the desired action will take place for a given day (indicated by the column). The color of the schedule entry indicates the desired action. The colors represent the following actions: <div style="display: flex; justify-content: space-around; align-items: center;"> <div style="text-align: center;"> Heat On</div> <div style="text-align: center;"> Heat Off</div> <div style="text-align: center;"> Disabled</div> </div>
	Create Schedule Entry	Press softkey to create a new schedule entry. Once pressed, a pop-up box will appear allowing the user to set the time of the schedule entry (24-hour clock) as well as the desired action (Heat On/Off).
	Delete Schedule Entry	Press softkey to delete selected schedule entry.
	Enable / Disable Schedule Entry	Press softkey to toggle the state (enabled or disabled) of the selected schedule entry.

Appendix B - USB Downloading, Uploading

The system can store 50,000 entries in its logs and the system adds a new entry to the logs every 60 seconds. This means the system stores 800 hours of system operation data, or 34 days of around-the-clock operation. Once full, the system will overwrite the oldest data.

NOTE: To prevent losing any data, never go more than 34 days without downloading the logs.

Download Procedure

NOTICE

Uploading an edited system configuration file can damage the system. Never put a modified SETTINGS.TXT file in the UPLOAD folder on the flash drive.

NOTE: The event log, error log, system settings, and system language files are all downloaded in this procedure. See **USB Logs**, **System Settings File**, and **System Language File** starting on page 94.

1. Insert USB flash drive into USB port (PT).

NOTE: Flash drive must be 8 GB or smaller.

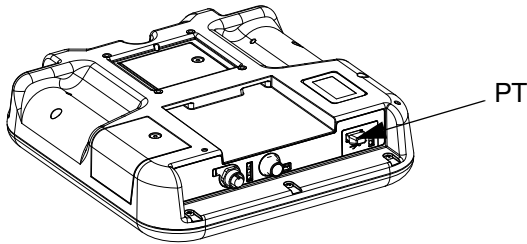

2. The menu bar and USB indicator lights indicate that the USB is downloading files. Wait for USB activity to complete. A pop-up will be present until the transfer is complete if it is not acknowledged.

NOTE: If the pop-up screen does not appear, the flash drive is not compatible with the ADM. Try a different flash drive.

NOTE: The system can log up to 45 mb of additional data per week, depending on system operation.

Accessing Files

All files downloaded from the USB are put in a DOWNLOAD folder on the stick drive. For example:

“E:\GRACO\12345678\DOWNLOAD\”. The 8-digit numeric folder name matches the 8-digit ADM serial number, which is located on the back of the ADM. When downloading from multiple ADMs, there will be one sub-folder in the GRACO folder for each ADM.

The log files should be opened in a spreadsheet program.

NOTE: If emailing the files, zip (compress) them to minimize file size.

Upload Procedure

NOTICE

Uploading an edited system configuration file can damage the system. Never put a modified SETTINGS.TXT file in the UPLOAD folder on the flash drive.

Use this procedure to install a system configuration file and/or a custom language file. See **System Settings File** or **System Language File** starting on page 94.

1. If necessary, follow the **System Language File**, page 95, to automatically generate the proper folder structure on the USB flash drive.
2. Insert USB flash drive into USB port of computer.
3. The USB flash drive window automatically opens. If it does not, open USB flash drive from within Windows Explorer.
4. Open Graco folder.
5. Open system folder. If working with more than one system, there will be more than one folder within the Graco folder. Each folder is labeled with the corresponding serial number of the ADM. (The serial number is on the back of the module.)
6. *If installing the system settings file*, place SETTINGS.TXT file into UPLOAD folder.
7. *If installing the custom language file*, place DISPTXT.TXT file into UPLOAD folder.
8. Remove USB flash drive from computer.
9. Install USB flash drive into InvisiPac system USB port.

10. The menu bar and USB indicator lights indicate that the USB is uploading files. Wait for USB activity to complete.

11. Remove USB flash drive from USB port.

NOTE: If a custom language file was installed, users can now select the new language from the Language drop-down menu.

NOTE: If the SETTINGS.TXT or DISPTXT.TXT files remain in the UPLOAD folder, they will be uploaded every time the USB drive is inserted into the corresponding ADM. To avoid unintentionally overwriting system settings, delete the files from the UPLOAD folders on the USB drive after the upload is complete.

USB Logs

During operation, InvisiPac stores system and performance related information to memory in the form of log files. InvisiPac maintains the events, data, GCA, Black Box, and Diagnostics logs. Follow the **System Language File**, page 95, to retrieve log files.

Events Log

The event log (1-EVENT.CSV) maintains a record of the last 75,000 events. Each event record in the log file contains the date and time the event occurred, the event type, event code, and event description.

Data Log

The data log (2-DATA.CSV) tracks the setpoint and actual temperatures every 60 seconds. This log can store up to 50,000 lines of data.

The system stores 800 hours of system operation data, or 34 days of around-the-clock operation. Once full, the system will overwrite the oldest data.

NOTE: To prevent losing any data, never go more than 34 days without downloading the logs.

GCA Log

This log (3-GCA.CSV) lists the installed GCA modules and their respective software versions.

Black Box, Diagnostics Logs

These logs (4-BLACKB.CSV, 5-DIAGNO.CSV) are designed to provide useful information to Graco when calling for technical assistance.

Material Log

This log (6-MATERI.CSV) lists up to 500 material log entries.

Fill Log

This log (7-FILL.CSV) is designed to provide useful information to Graco when calling for technical assistance.

System Settings File

NOTICE

Uploading an edited system configuration file can damage the system. Never put a modified SETTINGS.TXT file in the UPLOAD folder on the flash drive.

The system configuration settings file name is SETTINGS.TXT and is stored in the DOWNLOAD folder.

A system configuration settings file automatically downloads each time a USB flash drive is inserted. Use this file to back up system settings for future recovery or to easily replicate settings across multiple InvisiPac systems. Refer to the **Upload Procedure**, page 93, for instructions on how to use this file.

It is recommended to retrieve the SETTINGS.TXT file after all system settings are set as desired. Store the file for future use as a backup in case the settings are changed and need to be quickly changed back to the desired setup.

NOTE: System settings may not be compatible between different versions of the InvisiPac software.

System Language File

The system language file name is DISPTXT.TXT and is stored in the DOWNLOAD folder.

A system language file automatically downloads each time a USB flash drive is inserted. If desired, use this file to create a user-defined set of custom language strings to be displayed within the ADM.

The system is able to display the following Unicode characters. For characters outside of this set, the system will display the Unicode replacement character, which appears as a white question mark inside of a black diamond.

- U+0020 - U+007E (Basic Latin)
- U+00A1 - U+00FF (Latin-1 Supplement)
- U+0100 - U+017F (Latin Extended-A)
- U+0386 - U+03CE (Greek)
- U+0400 - U+045F (Cyrillic)

Create Custom Language Strings

The custom language file is a tab-delimited text file that contains two columns. The first column consists of a list of strings in the language selected at the time of download. The second column can be used to enter the custom language strings. If a custom language was previously installed, this column contains the custom strings. Otherwise the second column is blank.

Modify the second column of the custom language file as needed and then follow the **Upload Procedure**, page 93, to install the file.

The format of the custom language file is critical. The following rules must be followed in order for the installation process to succeed.

- The file name must be DISPTXT.TXT.
- The file format must be a tab-delimited text file using Unicode (UTF-16) character representation.
- The file must contain only two columns, with columns separated by a single tab character.
- Do not add or remove rows to the file.
- Do not change the order of the rows.
- Define a custom string for each row in the second column.

Appendix C - Software Update

Software Update Procedure

When software is updated on the ADM the software is then automatically updated on all connected GCA components. A status screen is shown while software is updating to indicate progress.

1. Turn system main power switch (H) OFF.
2. Remove ADM from bracket (BK).
3. Remove token access panel.

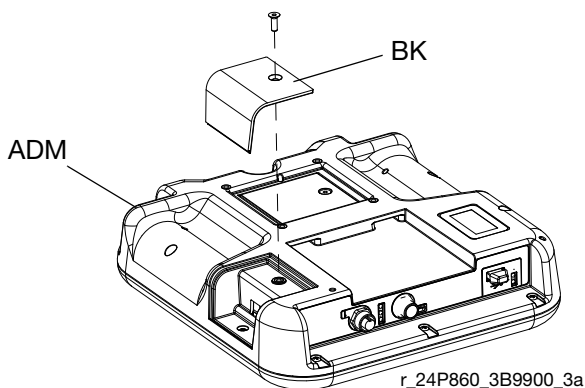

4. Insert and press InvisiPac software upgrade token (TK, part no. 17R827) firmly into slot.

NOTE: There is no preferred orientation of token.

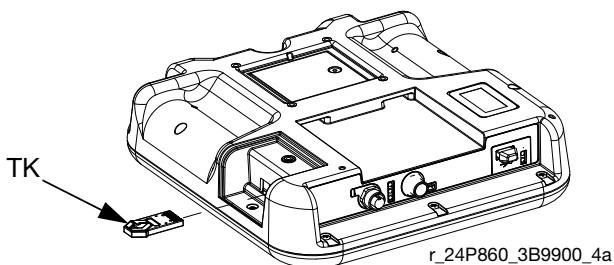

5. Install ADM into bracket (BK).
6. Turn system main power switch (H) ON.

NOTICE

A status is shown while software is updating to indicate progress. To prevent corrupting the software load, do not remove token until the status screen disappears.

NOTE: When the screen turns on, the following screens appear:

First:
Software is checking which GCA modules will take the available updates.



Second:
Status of the update with approximate time until completion.

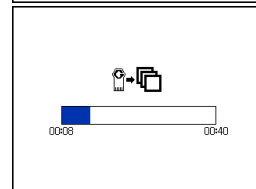

Third:
Updates are complete. Icon indicates update success/failure. See the following Icon table.

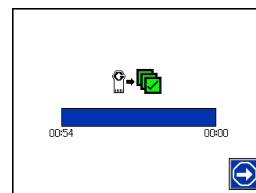

Icon	Description
	Update successful.
	Update unsuccessful.
	Update complete, no changes necessary.
	Update was successful/complete but one or more GCA modules did not have a CAN boot loader so software was not updated on that module.

7. Remove token (TK).
8. Replace token access panel.
9. Press to continue to InvisiPac operation screens.

Appendix D - Automation Gateway Interface

Overview

The Communications Gateway Module (CGM) provides a control link between the InvisiPac system and a selected fieldbus. This provides the means for report monitoring and control by external automation systems.

When the map file is installed into the CGM module, the HM25c ADM module should provide the “InvisiPac HM24c” map name. a “00001” map number and other information as indicated in the following information:

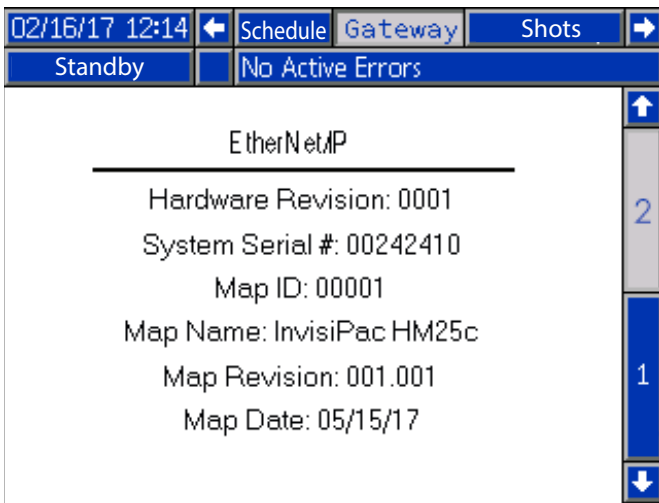

If using a Rockwell PLC to control the InvisiPac HM25c product and communication is established, the PLC should provide the following interface information on the PCB program.

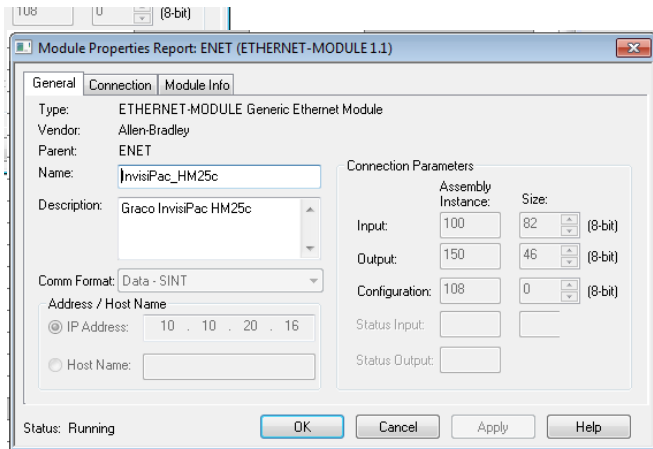

See **Available Internal Data** page 101 for a list of internal data from the InvisiPac system that can be viewed or modified by your fieldbus master.

Note: the following network configuration files are available at www.graco.com.

- EDS file: DeviceNet or Ethernet/IP fieldbus networks
- GSD file: PROFIBUS fieldbus networks
- GSDML: PROFINET fieldbus networks

Installation



1. Install the CGM in the desired location.
 - a. Remove access cover, (D). Loosen two screws (C) and remove CGM (A) from base (B).

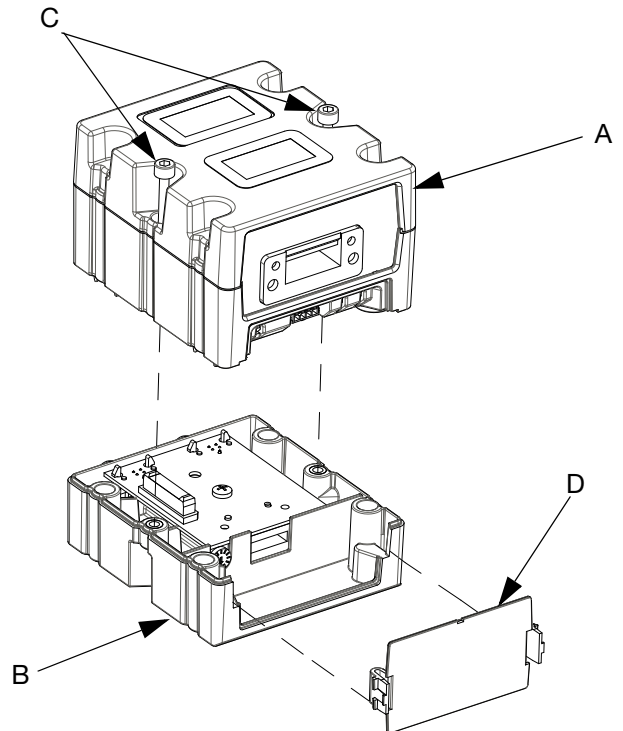

- b. Mount base (B) in desired location with four screws supplied in this kit. See the following mounting dimensions.

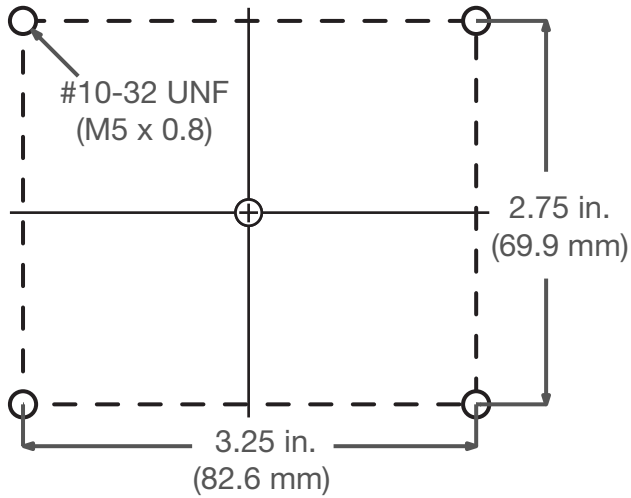

- c. Mount CGM (A) on base (B) with two screws (C).
2. Install access cover (D).
3. Connect CAN cable from either CAN connection on the CGM to the CAN connection found on the bottom of the ADM.

NOTICE

To avoid damage to GCA modules, ensure the CAN cable is connected to the appropriate CAN connection.

4. If used, connect the Ethernet, Devicenet, or PROFIBUS cable to the CGM as applicable. Connect the other end of the cable to the FieldBus device.

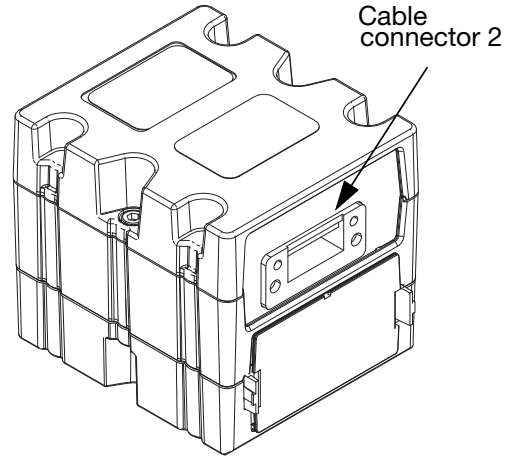

5. Perform the Install or Update Map Procedure in CGM manual 312864. **Related Manuals** page page 3.
6. See **Available Internal Data** on page 101 for details on fieldbus pinout setup.
7. Perform **SETUP** on page 99 to configure the FieldBus.

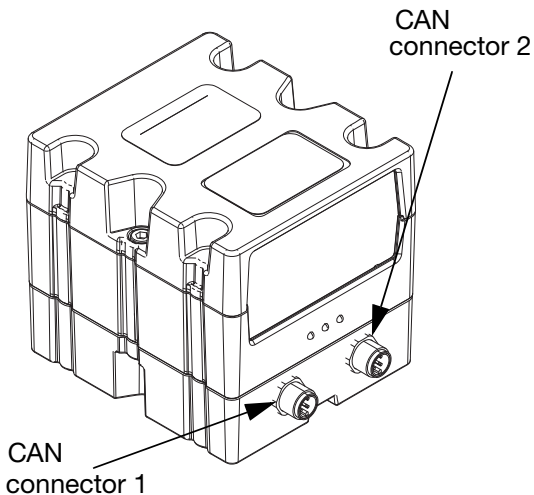

SETUP

Gateway Screens

The gateway screens are used to configure the fieldbus. These screens are shown only if a CGM is correctly installed. See **Installation** page 97.

1. With the system on and enabled, press  to access the setup screens.
2. Press the left arrow key once to navigate to the main gateway screen.

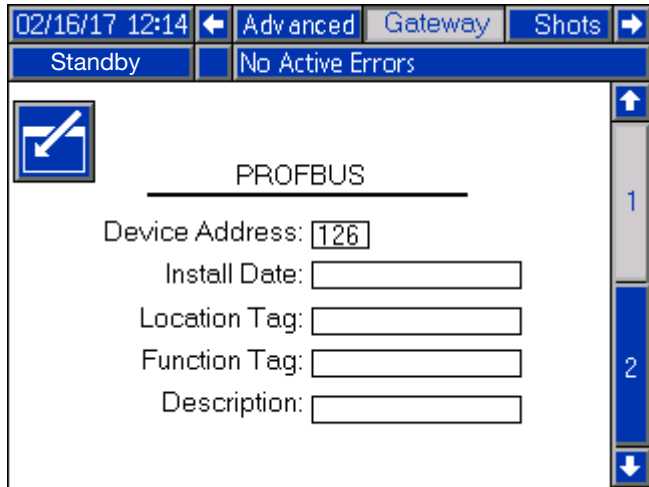

PROFIBUS Gateway Screens

These screens are shown only if a PROFIBUS fieldbus CGM is installed.

Screen 1

This screen enables the user to set the device address, install date, location tag, function tag, and description.

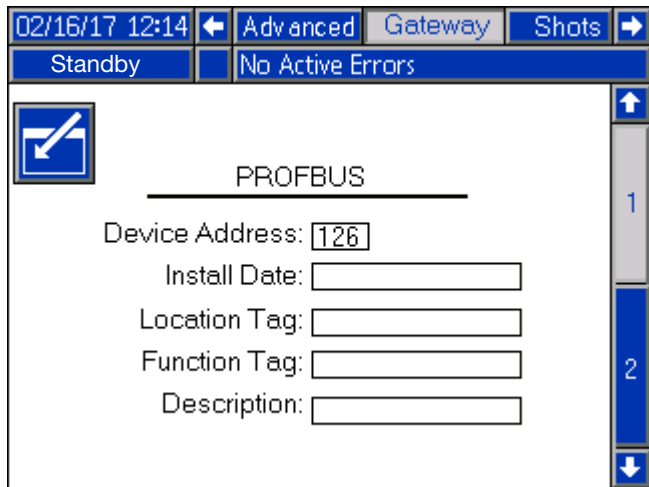

Screen 2

This screen displays the hardware revision, system serial number, and data map identification information.

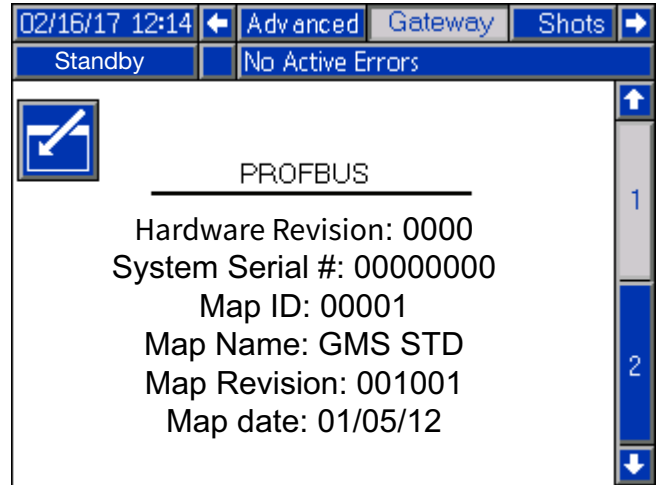

PROFINET Fieldbus Screens

These screens are shown only if the PROFINET fieldbus is installed.

Screen 1

This screen to set the IP address , DHCP settings, subnet mask, gateway, and DNS information.

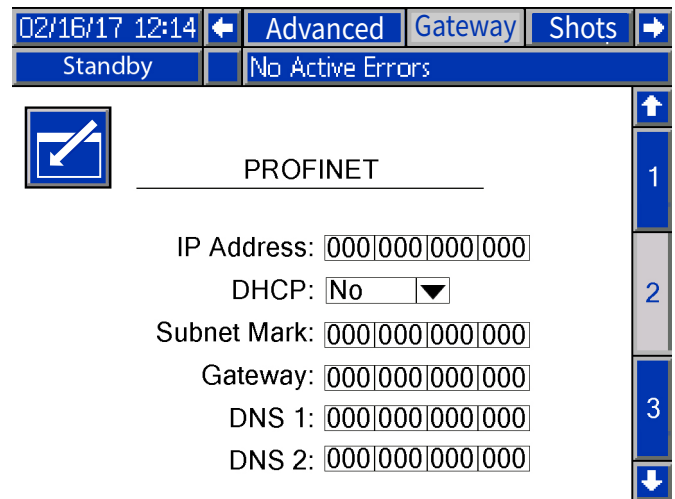

Screen 2

This screen enables the user to set the station name , install the date location tag, function tag, and description.

02/16/17 12:14	←	Advanced	Gateway	Shots	→
Standby		No Active Errors			
 <div style="text-align: center;">PROFINET</div>					
Station Name: <input type="text" value="GMS"/>					
Install Date: <input type="text" value="2008-08-14 15c08"/>					
Location and Tag: <input type="text" value="??"/>					
Function Tag: <input type="text"/>					
Description: <input type="text"/>					

Screen 3

This screen displays the hardware revision, system serial number, and data map identification information.

02/16/17 12:14	←	Advanced	Gateway	Shots	→
Standby		No Active Errors			
 <div style="text-align: center;">PROFINET</div>					
Hardware Revision: 0000					
System Serial #: 00000000					
Map ID: 00001					
Map Name: GMS STD					
Map revision: 001001					
Map Date: 01/06/12					

Ethernet/IP Fieldbus Screens

These screens are shown only if the Ethernet/IP Fieldbus CGM is installed.

Screen 1

This screen enables the user to set the IP address, DHCP settings, subnet mask, gateway, and DNS information.

02/16/17 12:14	←	Advanced	Gateway	Shots	→
Standby		No Active Errors			
 <div style="text-align: center;">EtherNet/IP</div>					
IP Address: <input type="text" value="192 168 001 052"/>					
DHCP:					
Subnet Mark: <input type="text" value="255 255 255 000"/>					
Gateway: <input type="text" value="000 000 000 000"/>					
DNS 1: <input type="text" value="005 002 001 002"/>					
DNS 2: <input type="text" value="005 002 001 002"/>					

Screen 2

This screen displays the hardware revision, system serial number, and data map identification information.

02/16/17 12:14	←	Advanced	Gateway	Shots	→
Standby		No Active Errors			
 <div style="text-align: center;">EtherNet/IP</div>					
Hardware Revision: 0000					
System Serial #: 00000000					
Map ID: 00001					
Map Name: GMS STD					
Map Revision: 001001					
Map Date: 01/05/12					

DeviceNet FieldBus Screen

This screen is shown only if a DeviceNet fieldbus is installed.

This screen enables the user to set the device address, baud rate, view the hardware revision system serial number, and data map identification information.

02/16/17 12:14	←	Advanced	Gateway	Shots	→
Standby		No Active Errors			
 DeviceNet					
Device Address: <input type="text" value="63"/>					
Baud rates: <input type="text" value="500"/> ▼					
Hardware Revision: 0000					
System Serial #: 00000000					
Map ID: 001					
Map Name: GMS STD					
Map Revision: 001001					
Map Date: 01/05/12					

Available Internal Data

See the **Automation Inputs** on page 103 for additional details regarding each input/output.

Unless stated otherwise:

- Bytes are stored in each instance in little endian order (byte order within instance: least significant to most significant).
- Values are subject to the same maximum and minimum restrictions of the ADM.

Automation inputs (signals from InvisiPac to PLC)

Instance ID	Output Byte (S)	Description	Units
1	1	System Heat State	N/A
2	2-3	Pump Flow Rate	lb/hr* or kg/hr*
3	4-7	Pump Lifetime Cycles	cycles
4	8-9	Melter Set point	°C/°F**
5	10-11	CH1 Gun Set point	°C/°F**
6	12-13	CH1 Hose Set point	°C/°F**
7	14-15	CH2 Gun Set point	°C/°F**
8	16-17	CH2 Hose Set point	°C/°F**
9	18-19	CH3 Gun Set point	°C/°F**
10	20-21	CH3 Hose Set point	°C/°F**
11	22-23	CH4 Gun Set point	°C/°F**
12	24-25	CH4 Hose Set point	°C/°F**
13	26-27	CH5 Gun Set point	°C/°F**
14	28-29	CH5 Hose Set point	°C/°F**
15	30-31	CH6 Gun Set point	°C/°F**
16	32-33	CH6 Hose Set point	°C/°F**
17	34-35	CH7 Gun Set point	°C/°F**
18	36-37	CH7 Hose Set point	°C/°F**
19	38-39	CH8 Gun Set point	°C/°F**
20	40-41	CH8 Hose Set point	°C/°F**
21	42-43	Melter Actual Temperature	°C/°F**
22	44-45	CH1 Gun Actual Temperature	°C/°F**
23	46-47	CH1 Hose Actual Temperature	°C/°F**
24	48-49	CH1 Gun Actual Temperature	°C/°F**
25	50-51	CH1 Hose Actual Temperature	°C/°F**
26	52-53	CH1 Gun Actual Temperature	°C/°F**
27	54-55	CH1 Hose Actual Temperature	°C/°F**
28	56-57	CH1 Gun Actual Temperature	°C/°F**
29	58-59	CH1 Hose Actual Temperature	°C/°F**
30	60-61	CH1 Gun Actual Temperature	°C/°F**
31	62-63	CH1 Hose Actual Temperature	°C/°F**
32	64-65	CH1 Gun Actual Temperature	°C/°F**
33	66-67	CH1 Hose Actual Temperature	°C/°F**
34	68-69	CH1 Gun Actual Temperature	°C/°F**
35	70-71	CH1 Hose Actual Temperature	°C/°F**
36	72-73	CH1 Gun Actual Temperature	°C/°F**
37	74-75	CH1 Hose Actual Temperature	°C/°F**
38	76	System Alarm Present	bool
39	77	System Advisory/Deviation Present	bool
40	78	Command Interface- status Bits	N/A***
41	79-82	Command Interface Value (Read/Write Return)	N/A***

Notes:

* - Mass Units match units of ADM. Values are in tenths (a value of 11 corresponds to 1.1 lb/hr).

** - Temperature Units match units of ADM. Values are in tenths of a degree (a value of 4000 corresponds to 400°F).

*** - See **Command Interface** page 105.

Automation inputs (signals from PLC to InvisiPac)

Instance ID	Output Byte (S)	Description	Units
42	1	System Activate	N/A
43	2	System Immediate Stop	N/A
44	3-4	Melter Set Point Request	°C/°F
45	5-6	CH1 Gun Set Point Request	°C/°F
46	7-8	CH1 Hose Set Point Request	°C/°F
47	9-10	CH2 Gun Set Point Request	°C/°F
48	11-12	CH2 Hose Set Point Request	°C/°F
49	13-14	CH3 Gun Set Point Request	°C/°F
50	15-16	CH3 Hose Set Point Request	°C/°F
51	17-18	CH4 Gun Set Point Request	°C/°F
52	19-20	CH4 Hose Set Point Request	°C/°F
53	21-22	CH5 Gun Set Point Request	°C/°F
54	23-24	CH5 Hose Set Point Request	°C/°F
55	25-26	CH6 Gun Set Point Request	°C/°F
56	27-28	CH6 Hose Set Point Request	°C/°F
57	29-30	CH7 Gun Set Point Request	°C/°F
58	31-32	CH7 Hose Set Point Request	°C/°F
59	33-34	CH8 Gun Set Point Request	°C/°F
60	35-36	CH8 Hose Set Point Request	°C/°F
61	37-40	Command interface - Command ID	°C/°F
62	41-44	Command Interface - Value (Write)	N/A**
63	45	Command Interface - Control Bits	N/A**
64	46	Unused	-

Notes:

* - Temperature Units match units of ADM. Values are in tenths of a degree (a value of 4000 corresponds to 400°F).

** - See **Command Interface** page number 105

Automation Inputs

This section provides details about the CGM automation and output signals.

System Heat State

This signal is 0 on power up. The following values of this signal correspond to the various system heat states.

Value	Heat state
0	Off
1	Warmup
2	At Temperature
3	Unknown

Melter Setpoint: This signal represents the current value of the melter temperature setpoint.

Zone Setpoint: This signal represents the current value of the given zone temperature setpoint.

Melter Temperature: This signal represents the current temperature of the melter.

Zone Temperature: This signal represents the current temperature of a given zone.

Pump Lifetime Cycles: This signal represents the current count of the pump's lifetime cycles.

Pump Alarm Preset: This signal indicates whether there are any active alarms. a value of True (1) indicates active alarms are present. To determine the alarm preset, refer to **Command Interface** page 105 for details on how to retrieve the event code.

System Advisory / Deviation Present: This signal indicates whether there are any active system advisories or deviations. A value of True (1) indicates active advisories or deviations are present. To determine the advisory/deviation present, refer to **Command Interface** page 105 for details on how to retrieve the event code.

Cmd Int - Status Bits: See **Command Interface** page 105.

Cmd Int - Value: See **Command Interface** page 105.

System Activate: This signal is used to activate the system. The System Activate has the same function as the  button. Set this signal to 1 in order to activate the system.

System Immediate Stop: This bit is used to immediately stop the system. The System Immediate Stop has the same function as the  button. Set this signal to 1 in order to immediately stop the system.

Melter Setpoint Request: This signal is used to request a new setpoint temperature for the melter (units match ADM temp. units). If the value supplied is within the operable range, this value will be accepted by the ADM.

Zone Setpoint Request: This signal is used to request a new setpoint temperature for the given zone (units match ADM temp. units). If the value is within the operable range, this value will be accepted by the ADM.

Cmd int - Command: See **Command Interface** page 105.

Cmd Int - Value: See **Command Interface** page 105.

Cmd Int - Control Bits: See **Command Interface** page 105.

Command Interface

This section provides details about the CGM Command Interface.

The command interface portion of the map, allows the user to request further information or control more parameters of the InvisiPak system, which are not part of the other assigned memory locations. The command interface variables are assigned instance locations 40, 41, 61, 62 and 63 outlined in the **Automation inputs (signals from InvisiPac to PLC)** page 102 and **Automation inputs (signals from PLC to InvisiPac)** page 103.

The **Command Interface Timing Diagram** along with the **Command Interface Read operation**, should be used in order to read/write the command interface variables.

NOTE: When changes are made using the Command Interface, the ADM screen may not update immediately. It may be necessary to navigate to another screen, then back to the original screen.

Command Interface Timing Diagram

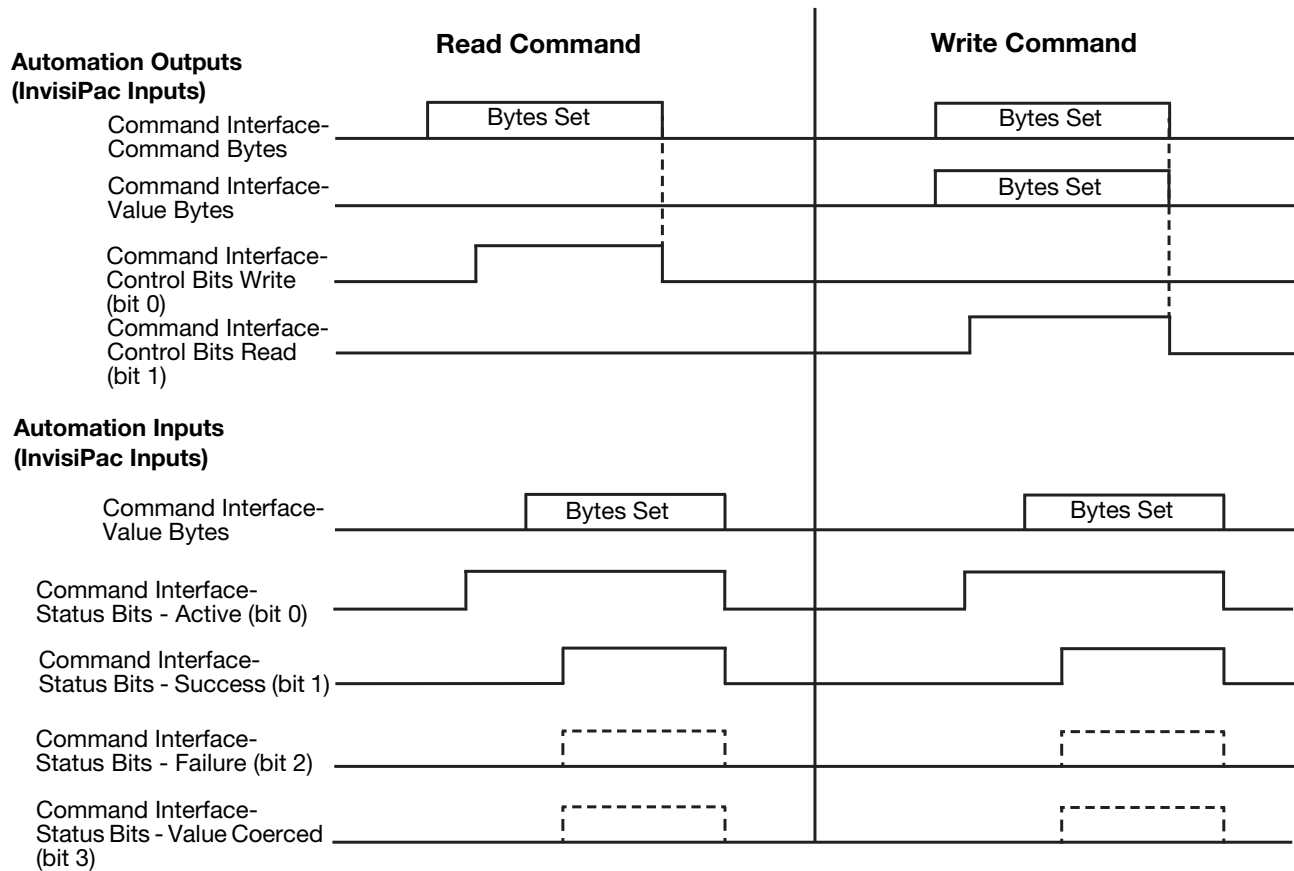

Command Interface Read operation

1. Set Command Interface - Command ID Byte to the desired value. See **Command Interface Table** page 106 for available values.
2. Set Command Interface - Control - Read Bit (bit 0).
3. Wait for the Command Interface - Status bits Active (bit 0) to become set.

4. Wait for the Command Interface - Status Bits Success (bit 1) to become set.

NOTE: if the Command Interface - Success has been set , valid data will be present within the Command Interface Value (Read/Write Return) Bytes (automation input).

5. Clear the Command Interface - Control - Read Bit (bit - 0) to the end the read command operation.

Command Interface Write Operation

1. Set Command Interface - Command ID (Write) Byte to the desired value. See **Command Interface Table** page 106 for available values.
2. Set Command Interface _ Value (Automation Output) byte to the value that is desired to be written.
3. Set Command Interface - Write Bit (bit 1).
4. Wait for the Command Interface - Status Bits - Active (bit 0) to become set. This indicates than an operation is in process.
5. Wait for the Command Interface - Status Bits - Success (bit 1), Command Interface - Status bits - Failure (bit 2), or Command Interface - Status bits - Value Coerced (bit 3) to become set.

NOTE: The Command Interface - Value (Read/Write Return) (automation input) bytes will now contain the value that was actually written.

6. Clear the Command Interface - Control - Write Bit (bit 1) to end the write command operation.

Command Interface Table

Command Interface - Command ID	Description	Variable Definition	Read/Write
0x0100	System Date	A 32-bit string in the format of 0xDDCCBBAA. 0xDD...Year (0x0D corresponds to 2013) 0xCC...Month (0x0A corresponds to October) 0xBB...Day 0xAA...Day of Week (0x01 corresponds to Monday)	Read
0x0101	System Time	A 32-bit string in the format of 0xDDCCBBAA. 0xDD...Unused 0xCC...Hours 0xBB...Minutes 0xAA...Seconds	Read
0x010A	Weight Per Box	Weight per unit in thousandths (a value of 1000 corresponds to 1.000 grams per unit)	Read
0x0303	Temperature Units	Value - Setting 0 - °F 1 - °C	Read/Write
0x0304	Mass Units	Value - Setting 0 - kg 1 - lb	Read/Write

Command Interface - Command ID	Description	Variable Definition	Read/Write
0x0305	Distance Units	Value - Setting 0 - in 1 - mm	Read/Write
0x0306	Specific Graviyt	Specific Gravity in thousands (a value of 1000 corresponds to 1.000 grams/cc)	Read/Write
0x0307	Customer Input 1 Type	Value - Setting 0 - Unused 1 - Heaters On/Off 2 - Pump Enable/Disable 3 - Channel 1 Enable/Disable 4 - Channel 2 Enable/Disable 5 - Channel 3 Enable/Disable 6 - Channel 4 Enable/Disable 7 - Channel 5 Enable/Disable 8 - Channel 6 Enable/Disable 9 - Channel 7 Enable/Disable 10 - Channel 8 Enable/Disable	Read/Write
0x0308	Customer Input 2 Type	Customer Input 2 Type	Read/Write
0x0309	Customer Input 3 Type	See Customer Input 1 Type	Read/Write
0x030A	Customer Input 4 Type	See Customer Input 1 Type	Read/Write
0x030B	Customer Input 5 Type	See Customer Input 1 Type	Read/Write
0x030C	Customer Input 6 Type	See Customer Input 1 Type	Read/Write
0x030D	Customer Output 1 Type	Value - Setting 0 - Unused 1 - System Ready 2 - Error (Alarm) 3 - Error (Deviation/Advisory) 4 - Maintenance Due	Read/Write
0x030E	Customer Output 2 Type	See Customer Output 1 Type	Read/Write
0x030E	Channel installed Bitmask	Bit...Channel 0.....Channel1 1.....Channel 2 2.....Channel 3 3.....Channel 4 4.....Channel 5 5.....Channel 6 6.....Channel 7 7.....Channel 8 A value of 0x0F enables channels 1-4 and disables channels 5-8. A value of 0 x F0 disables this feature and enables channels 5-8.	Read/Write
0x0310	Pump Idle Time to System Inactive	Pump idle time to system inactive in minutes NOTE: a value of 0 disables this feature (system will never go inactive due to pump inactivity)	Read/Write
0x0311	Circuit Breaker Size	Circuit breaker size in mA (a value of 20000 corresponds to a 20 A breaker on the power supplied to the system)	Read/Write

Command Interface - Command ID	Description	Variable Definition	Read/Write
0x0313	Refill Setting	Value - Setting 0 - Manual Refill 1 - Automatic Refill	Read/Write
0x0318	CH1 Gun RTD type	See CH1 Gun RTD Type	Read/Write
0x0319	CH2 Gun RTD type	See CH1 Gun RTD Type	Read/Write
0x031A	CH3 Gun RTD type	See CH1 Gun RTD Type	Read/Write
0x031B	CH4 Gun RTD type	See CH1 Gun RTD Type	Read/Write
0x031C	CH5 Gun RTD type	See CH1 Gun RTD Type	Read/Write
0x031D	CH6 Gun RTD type	See CH1 Gun RTD Type	Read/Write
0x031E	CH7 Gun RTD type	See CH1 Gun RTD Type	Read/Write
0x031E	CH8 Gun RTD type	See CH1 Gun RTD Type	Read/Write
0x0401	Resettable Pump Cycle Counter	Resettable pump cycle count. Write value of 0 to reset counter.	Read/Write
0x0402	Pump Lifetime Cycle Counter	Lifetime pump cycle count.	Read
0x0403	Resettable AUX Unit Counter	Resettable AUX unit count. Write value of 0 to reset counter. NOTE: this counter only includes units counted using the sensor on the System IO Board, not units counted using the pattern controller.	Read/Write
0x0404	Lifetime AUX Unit Counter	Lifetime AUX unit count. NOTE: this counter only includes units counted using the sensor on the System IO Board, not units counted using the pattern controller	Read
0x0407	Resettable Pump Weight Totalizer	Resettable pump weight totalizer in tenths of lbs or kgs (follows the Mass Units setting selected). Write value of 0 to reset totalizer.	Read/Write
0x0408	Pump Lifetime Weight Totalizer	Lifetime pump weight totalizer in tenths of lbs or kgs (follows the Mass Units setting selected).	Read
0x0605	Acknowledge All Events	Value - Setting Any - Acknowledges all system events requiring acknowledgment (if any are present)	Write
0x0606	Acknowledge Event	Returns current event (flashing on ADM screen) requiring acknowledgment (if any are present) in the format of 0xDDCCBBAA. AA - first character of error code BB - second character of error code CC - third character of error code DD - fourth character of error code	Write
0x0607	Acknowledge Current Event	Acknowledges current event (flashing on ADM screen) that requires acknowledgment (if any are present)	Write
0x0608	Current Event	Returns current event (flashing on ADM screen) requiring acknowledgment (if any are present) in the format of 0xDDCCBBAA. AA - first character of error code BB - second character of error code CC - third character of error code DD - fourth character of error code	Read

Command Interface - Command ID	Description	Variable Definition	Read/Write
0x0731 - 0x07F0	Pattern Bead Offset (8 guns, 24 beads per gun)	Used to set the offset of a bead within the active pattern (see Bead Offset Lookup Table to determine the appropriate command for each bead/gun combination). Values are in units of hundredths of inches or tenths of millimeters (matched the ADM distance units selected).	Read/Write
0x07F1 - 0x08B0	Pattern Bead Length (8 guns, 24 beads per gun)	Used to set the length of a bead within the active pattern (see Bead Length Lookup Table to determine the appropriate command for each bead/gun combination). Values are in units of hundredths of inches or tenths of millimeters (matched the ADM distance units selected). A value of 0 signifies a blank or empty bead.	Read/Write
0x802F	Line 1 Line Speed	Line speed of Line 1. Values are in hundredths of ft/min. or m/min (matches the ADM distance units selected).	Read
0x8030	Line 2 Line Speed	Line speed of Line 2. Values are in hundredths of ft/min. or m/min (matches the ADM distance units selected).	Read
0x8031	Line 1 Box Rate	Boxes per minute on Line 1.	Read
0x8032	Line 2 Box Rate	Boxes per minute on Line 2.	Read
0x8038	Pattern Controller Locked	Value - Setting 0 - Pattern controller is not locked (able to dispense) 1 - Pattern controller is locked (not able to dispense)	Read/Write
0x8067	Pattern Controller State	Value - Setting 0 - Locked 1 - Disabled (via PLC Input) 2 - Off (Inactive) 3 - Active	Read
0x8101	Active Program	Active pattern controller program.	Read/Write
0x8119	Trigger 1 Reverse Polarity	Value - Setting 0 - Normal Polarity (signal asserted high/low indicates unit present) 1 - Reverse Polarity (signal asserted high/low indicates unit absent)	Read/Write
0x811A	Trigger 2 Reverse Polarity	See Trigger 1 Reverse Polarity	Read/Write
0x811B	Trigger 3 Reverse Polarity	Trigger 3 Reverse Polarity	Read/Write
0x811C	Trigger 4 Reverse Polarity	See Trigger 1 Reverse Polarity	Read/Write
0x811D	Trigger 1 Line Select	Value - Setting 1 - Trigger is used for Line 1 2 - Trigger is used for Line 2	Read/Write
0x811E	Trigger 2 Line Select	See Trigger 1 Line Select	Read/Write
0x811F	Trigger 3 Line Select	See Trigger 1 Line Select	
0x8120	Trigger 4 Line Select	See Trigger 1 Line Select	Read/Write
0x812F	Line 1 Line Speed Mode	Value - Setting 1 - Fixed Line Speed Mode 2 - Encoder Mode	Read/Write
0x8130	Line 2 Line Speed Mode	See Line 1 Line Speed Mode	Read/Write

Command Interface - Command ID	Description	Variable Definition	Read/Write
0x8131	Line 1 Encoder Scaling	Encoder scaling in thousandths of pulses/mm (a value of 3333 corresponds to 3.333 pulses/mm)	Read/Write
0x8132	Line 2 Encoder Scaling	See Line 1 Encoder Scaling	Read/Write
0x8133	Line 1 Fixed Line Speed	Line 1 fixed line speed. Values are in hundredths of ft/min. or m/min (matches the ADM distance units selected).	Read/Write
0x8134	Line 2 Fixed Line Speed	See Line 1 Fixed Line Speed	Read/Write
0x81A9	Line 1 Resettable Unit Counter	Resettable Line 1 unit count. Write value of 0 to reset counter	Read/Write
0x81AA	Line 2 Resettable Unit Counter	See Line 1 Resettable Unit Counter	Read/Write
0x81AB	Line 1 Lifetime Unit Counter	Lifetime Line 1 unit count.	Read
0x81AC	Line 2 Lifetime Unit Counter	See Line 1 Lifetime Unit Counter	Read

Bead Offset Lookup Table

Bead Number	Gun 1	Gun 2	Gun 3	Gun 4	Gun 5	Gun 6	Gun 7	Gun 8
1	0x0731	0x0732	0x0733	0x0734	0x0735	0x0736	0x0737	0x0738
2	0x0739	0x073A	0x073B	0x073C	0x073D	0x073E	0x073F	0x0740
3	0x0741	0x0742	0x0743	0x0744	0x0745	0x0746	0x0747	0x0748
4	0x0749	0x074A	0x074B	0x074C	0x074D	0x074E	0x074F	0x0750
5	0x0751	0x0752	0x0753	0x0754	0x0755	0x0756	0x0757	0x0758
6	0x0759	0x075A	0x075B	0x075C	0x075D	0x075E	0x075F	0x0760
7	0x0761	0x0762	0x0763	0x0764	0x0765	0x0766	0x0767	0x0768
8	0x0769	0x076A	0x076B	0x076C	0x076D	0x076E	0x076F	0x0770
9	0x0771	0x0772	0x0773	0x0774	0x0775	0x0776	0x0777	0x0778
10	0x0779	0x077A	0x077B	0x077C	0x077D	0x077E	0x077F	0x0780
11	0x0781	0x0782	0x0783	0x0784	0x0785	0x0786	0x0787	0x0788
12	0x0789	0x078A	0x078B	0x078C	0x078D	0x078E	0x078F	0x0790
13	0x0791	0x0792	0x0793	0x0794	0x0795	0x0796	0x0797	0x0798
14	0x0799	0x079A	0x079B	0x079C	0x079D	0x079E	0x079F	0x07A0
15	0x07A1	0x07A2	0x07A3	0x07A4	0x07A5	0x07A6	0x07A7	0x07A8
16	0x07A9	0x07AA	0x07AB	0x07AC	0x07AD	0x07AE	0x07AF	0x07B0
17	0x07B1	0x07B2	0x07B3	0x07B4	0x07B5	0x07B6	0x07B7	0x07B8
18	0x07B9	0x07BA	0x07BB	0x07BC	0x07BD	0x07BE	0x07BF	0x07C0
19	0x07C1	0x07C2	0x07C3	0x07C4	0x07C5	0x07C6	0x07C7	0x07C8
20	0x07C9	0x07CA	0x07CB	0x07CC	0x07CD	0x07CE	0x07CF	0x07D0
21	0x07D1	0x07D2	0x07D3	0x07D4	0x07D5	0x07D6	0x07D7	0x07D8
22	0x07D9	0x07DA	0x07DB	0x07DC	0x07DD	0x07DE	0x07DF	0x07E0
23	0x07E1	0x07E2	0x07E3	0x07E4	0x07E5	0x07E6	0x07E7	0x07E8
24	0x07E9	0x07EA	0x07EB	0x07EC	0x07ED	0x07EE	0x07EF	0x07F0

Bead Length Lookup Table

Bead Number	Gun 1	Gun 2	Gun 3	Gun 4	Gun 5	Gun 6	Gun 7	Gun 8
1	0x07F1	0x07F2	0x07F3	0x07F4	0x07F5	0x07F6	0x07F7	0x07F8
2	0x07F9	0x07FA	0x07FB	0x07FC	0x07FD	0x07FE	0x07FF	0x0800
3	0x0801	0x0802	0x0803	0x0804	0x0805	0x0806	0x0807	0x0808
4	0x0809	0x080A	0x080B	0x0080C	0x080D	0x080E	0x080F	0x0810
5	0x0811	0x0812	0x0813	0x0814	0x0815	0x0816	0x0817	0x0818
6	0x0819	0x081A	0x081B	0x081C	0x081D	0x081E	0x081F	0x0820
7	0x0821	0x0822	0x0823	0x0824	0x0825	0x0826	0x0827	0x0828
8	0x0829	0x082A	0x082B	0x082C	0x082D	0x082E	0x082F	0x0830
9	0x0831	0x0832	0x0833	0x0834	0x0835	0x0836	0x0837	0x0838
10	0x0839	0x083A	0x083B	0x083C	0x083D	0x083E	0x083F	0x0840
11	0x0841	0x0842	0x0843	0x0844	0x0845	0x0846	0x0847	0x0848
12	0x0849	0x084A	0x084B	0x084C	0x084D	0x084E	0x084F	0x0850
13	0x0851	0x0852	0x0853	0x0854	0x0855	0x0856	0x0857	0x0858
14	0x0859	0x085A	0x085B	0x085C	0x085D	0x085E	0x085F	0x0860
15	0x0861	0x0862	0x0863	0x0864	0x0865	0x0866	0x0867	0x0868
16	0x0869	0x086A	0x086B	0x086C	0x086D	0x086E	0x086F	0x0870
17	0x0871	0x0872	0x0873	0x0874	0x0875	0x0876	0x0877	0x0878
18	0x0879	0x087A	0x087B	0x087C	0x087D	0x087E	0x087F	0x0880
19	0x0881	0x0882	0x0883	0x0884	0x0885	0x0886	0x0887	0x0888
20	0x0889	0x088A	0x088B	0x088C	0x088D	0x088E	0x088F	0x0890
21	0x0891	0x0892	0x0893	0x0894	0x0895	0x0896	0x0897	0x0898
22	0x0899	0x089A	0x089B	0x089C	0x089D	0x089E	0x089F	0x08A0
23	0x08A1	0x08A2	0x08A3	0x08A4	0x08A5	0x08A6	0x08A7	0x08A8
24	0x08A9	0x08AA	0x08AB	0x08AC	0x08AD	0x08AE	0x08AF	0x08B0

Dimensions

240V System Dimensions

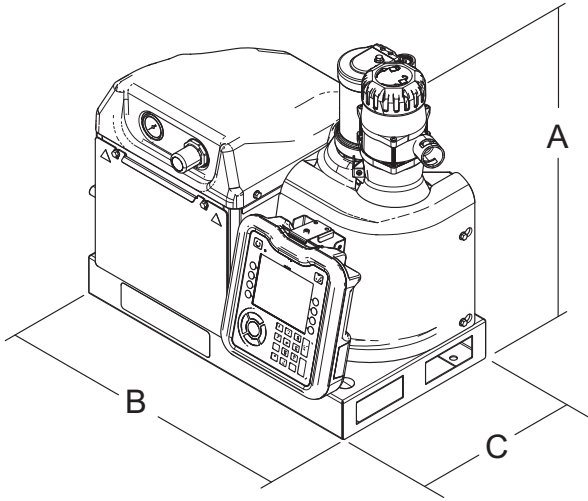

ti30882a

- A 23.1 in. (58.7 cm)
- B 25.4 in. (64.5 cm)
- C 16.5 in. (41.9 cm)

System with 480V Transformer

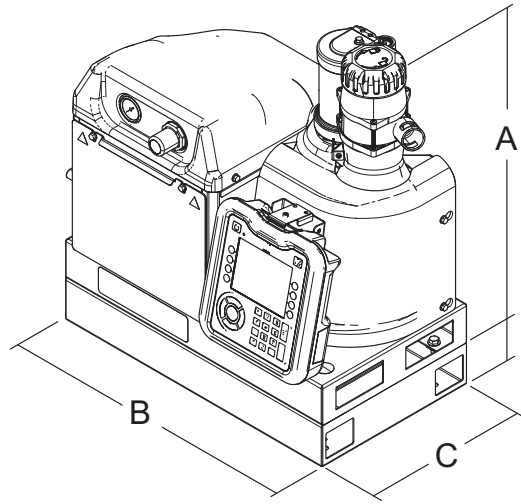

ti30883a

- A 26.3 in. (66.8 cm)
- B 25.4 in. (64.5 cm)
- C 16.5 in. (41.9 cm)

Mounting Hole Dimensions

240V Systems

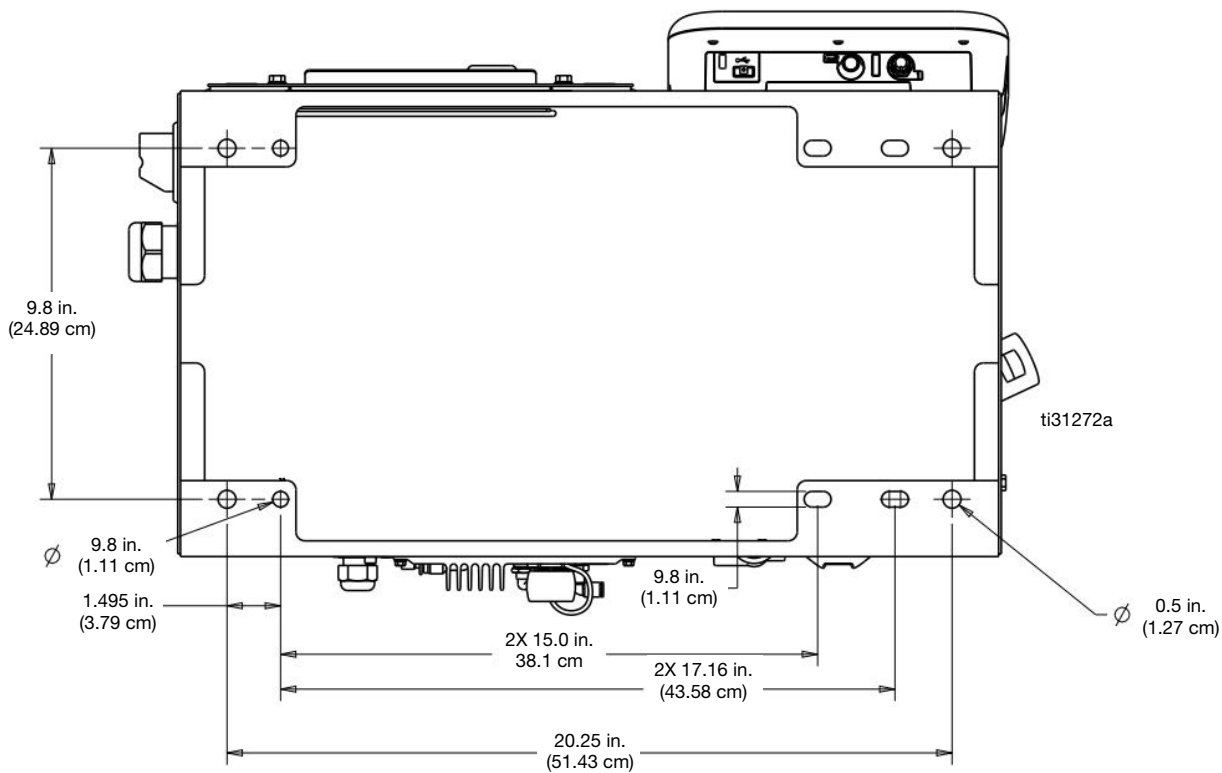

480V Systems

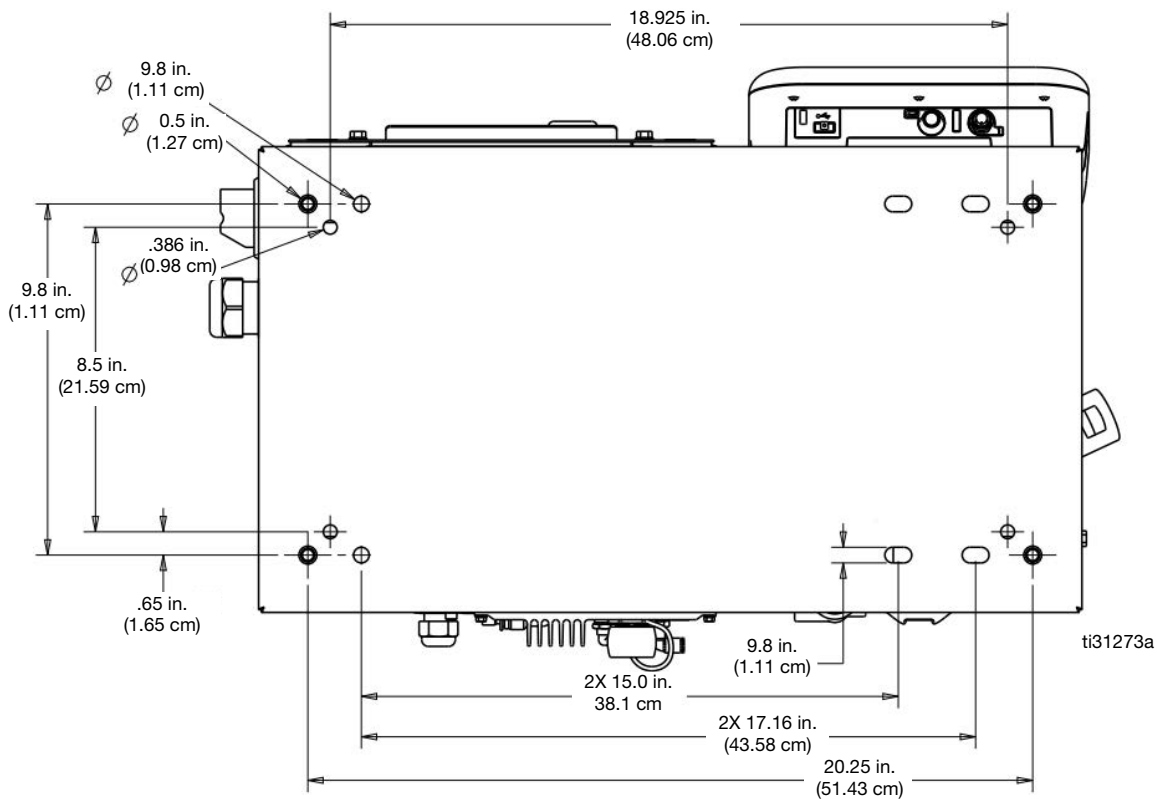

System with Stand and Feed Hose Dimensions

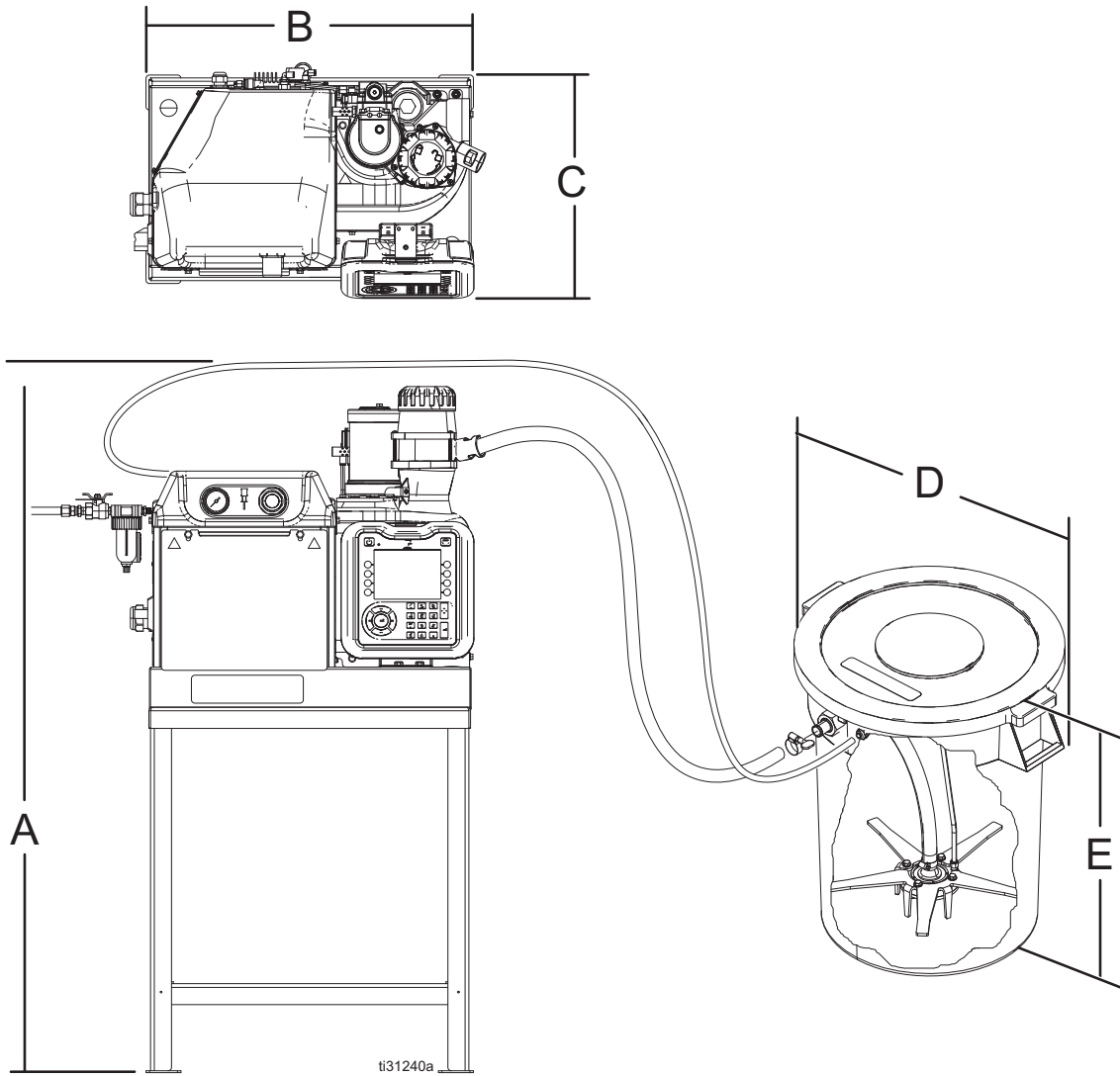

	240V Systems	480V Systems
A	49.3 in. (125.2 cm)	52.5 in. (133.4 cm)
B	25.4 in. (64.5 cm)	25.4 in. (64.5 cm)
C	16.5 in. (41.9 cm)	16.5 in. (41.9 cm)
D	26.0 in. (66.0 cm)	26. in. (66.0 cm)
E	28.0 in. (71.1 cm)	28.0 in. (71.1 cm)

Technical Specifications

InvisiPac HM25c Hot Melt Delivery System		
	US	Metric
Incoming Power		
HM25c: 25C700, 25C701, 25C702, 25C703	200-240 VAC, 1-ph, 50/60 Hz, 32 A 200-240 VAC, 3-ph, Δ, 50/60 Hz, 32 A 350-415 VAC, 3-ph, Y, 50/60 Hz, 32 A	
HM25c: 25C720, 25C721, 25C722, 25C723	400-480 VAC, 3-ph, Δ, 50/60 Hz, 16A	
Electrical		
Minimum Applicator Wattage Per Channel	90 W (@ 240 VAC)	
Maximum Applicator Wattage Per Channel	400 W (@ 240 VAC)	
Minimum Hose Wattage Per Channel	90 W (@ 240 VAC)	
Maximum Hose Wattage Per Channel	1250 W (@240 VAC)	
PLC Inputs	6 inputs (0-30 VDC)	
PLC Outputs	2 outputs (240 VAC / 24 VDC, 2 A max)	
Pump Flow Rate		
HM25c	96 lb/hr	43.5 kg/hr
Melt Rate / Constant Throughout		
HM25c	25 lb/hr	11.3kg/hr
Weight		
HM25c: 25C700, 25C701, 25C702, 25C703	86 lb	39 kg
HM25c: 25C720, 25C721, 25C722, 25C723	160 lb	73 kg
General		
Pump Output	19.3 cc/cycle	
Time to Temperature*	Less than 10 minutes	
Pump	Pneumatic Piston, 12:1	
Channels	0-8 channels	
Pressure and Temperature Ranges		
System Air Supply Inlet	80-100 psi	0.55-0.69 MPa (5.5-7 bar)
Pump Operating Air Pressure Range (set with regulator on front of system)	20-100 psi	0.14-0.69 MPa (0.7-7 bar)
Pump Operating Fluid Pressure Range	240-1200 psi	1.7-8 MPa (17-80 bar)
Control Temperature Range	100°-400° F	38°-204° C
Ambient Temperature Range	32°-120° F	0°-49° C
Air Consumption Specifications		
Average air use at 5 lb/hour**	1.9 scfm	3.3 scmh
Average air use at 25 lb/hour**	5.4 scfm	9.2 scmh
Feed Hose Specifications		
Maximum Feed Hose Length	30 ft	9.1 m
Maximum Feed Hose Vertical Rise	10 ft	3.0 m

InvisiPac HM25c Hot Melt Delivery System		
	US	Metric
Required Air Tubing Size		
Minimum Air Tubing Inner Diameter	3/8 in.	9.5 mm
Minimum Air Tubing Inner Diameter (50 ft, 15.2 m or longer tubing)	1/2 in.	12.7 mm
Sound		
Sound Pressure Level***	77 db(A)	
IP Code		
HM25c	IP54	
Wetted Parts		
Wetted Parts	PTFE, chemically resistant o-rings, aluminum, stainless steel, zinc plating, carbon steel, brass, carbide, chrome	
<p>* From 70°F to 350° F (21° C to 177° C), dependent upon power supply and machine configuration. ** Includes intermittent air use up to 13 scfm (22 scmh) when vacuum system is feeding. *** Sound pressure level measured 3.1 ft (1 meter) from equipment.</p>		

California Proposition 65

CALIFORNIA RESIDENTS

 **WARNING:** Cancer and reproductive harm – www.P65warnings.ca.gov.

Startup Time

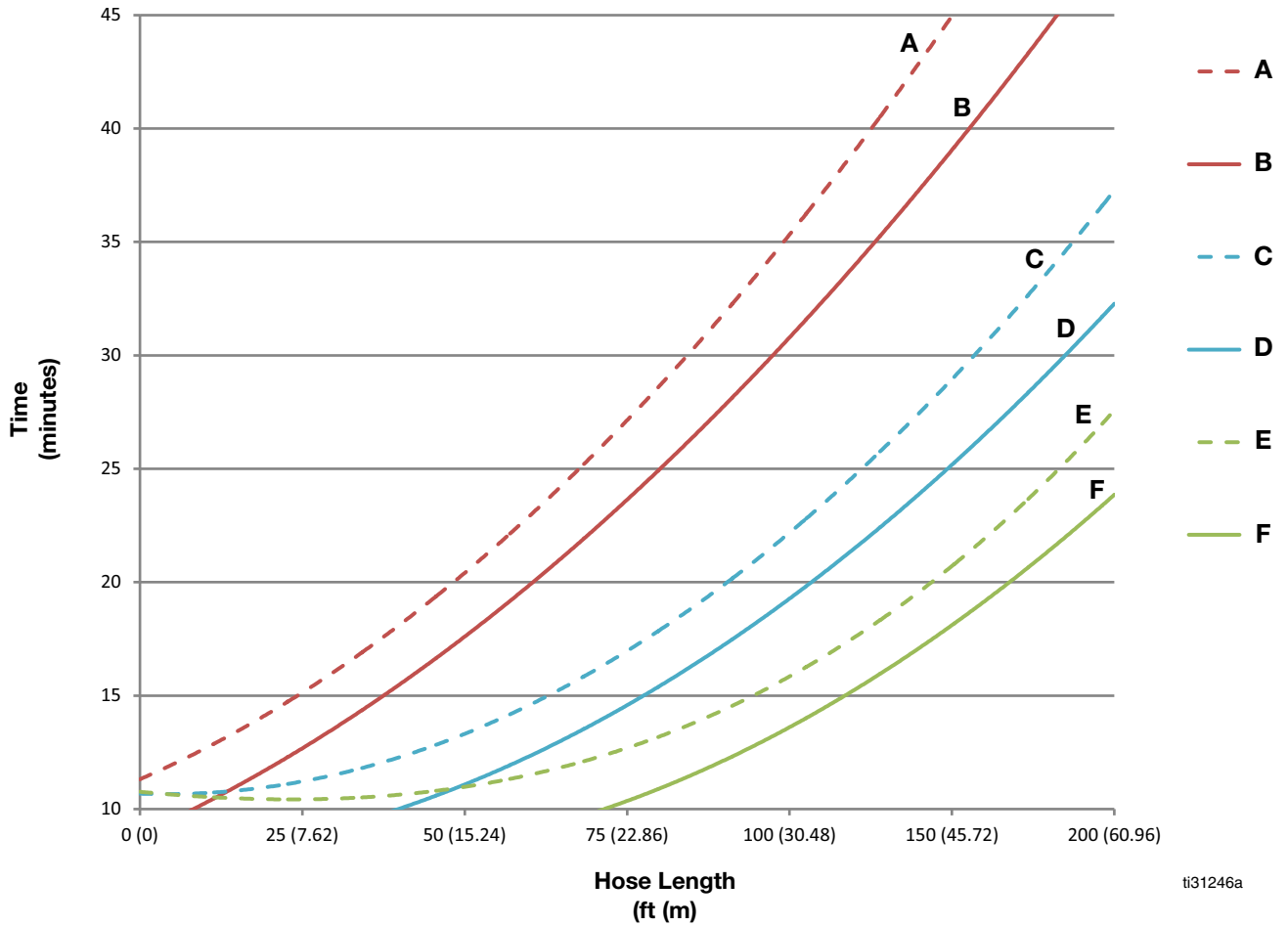

- A** 20 Amp 208V Heatup Time
- B** 20 Amp 240V Heatup Time
- C** 30 Amp 208V Heatup Time
- D** 30 Amp 240V Heatup Time
- E** 40 Amp 208V Heatup Time
- F** 40 Amp 240V Heatup Time

Graco Standard Warranty

Graco warrants all equipment referenced in this document which is manufactured by Graco and bearing its name to be free from defects in material and workmanship on the date of sale to the original purchaser for use. With the exception of any special, extended, or limited warranty published by Graco, Graco will, for a period of eighteen months from the date of sale, repair or replace any part of the equipment determined by Graco to be defective. This warranty applies only when the equipment is installed, operated and maintained in accordance with Graco's written recommendations.

This warranty does not cover, and Graco shall not be liable for general wear and tear, or any malfunction, damage or wear caused by faulty installation, misapplication, abrasion, corrosion, inadequate or improper maintenance, negligence, accident, tampering, or substitution of non-Graco component parts. Nor shall Graco be liable for malfunction, damage or wear caused by the incompatibility of Graco equipment with structures, accessories, equipment or materials not supplied by Graco, or the improper design, manufacture, installation, operation or maintenance of structures, accessories, equipment or materials not supplied by Graco.

This warranty is conditioned upon the prepaid return of the equipment claimed to be defective to an authorized Graco distributor for verification of the claimed defect. If the claimed defect is verified, Graco will repair or replace free of charge any defective parts. The equipment will be returned to the original purchaser transportation prepaid. If inspection of the equipment does not disclose any defect in material or workmanship, repairs will be made at a reasonable charge, which charges may include the costs of parts, labor, and transportation.

THIS WARRANTY IS EXCLUSIVE, AND IS IN LIEU OF ANY OTHER WARRANTIES, EXPRESS OR IMPLIED, INCLUDING BUT NOT LIMITED TO WARRANTY OF MERCHANTABILITY OR WARRANTY OF FITNESS FOR A PARTICULAR PURPOSE.

Graco's sole obligation and buyer's sole remedy for any breach of warranty shall be as set forth above. The buyer agrees that no other remedy (including, but not limited to, incidental or consequential damages for lost profits, lost sales, injury to person or property, or any other incidental or consequential loss) shall be available. Any action for breach of warranty must be brought within two (2) years of the date of sale.

GRACO MAKES NO WARRANTY, AND DISCLAIMS ALL IMPLIED WARRANTIES OF MERCHANTABILITY AND FITNESS FOR A PARTICULAR PURPOSE, IN CONNECTION WITH ACCESSORIES, EQUIPMENT, MATERIALS OR COMPONENTS SOLD BUT NOT MANUFACTURED BY GRACO. These items sold, but not manufactured by Graco (such as electric motors, switches, hose, etc.), are subject to the warranty, if any, of their manufacturer. Graco will provide purchaser with reasonable assistance in making any claim for breach of these warranties.

In no event will Graco be liable for indirect, incidental, special or consequential damages resulting from Graco supplying equipment hereunder, or the furnishing, performance, or use of any products or other goods sold hereto, whether due to a breach of contract, breach of warranty, the negligence of Graco, or otherwise.

FOR GRACO CANADA CUSTOMERS

The Parties acknowledge that they have required that the present document, as well as all documents, notices and legal proceedings entered into, given or instituted pursuant hereto or relating directly or indirectly hereto, be drawn up in English. Les parties reconnaissent avoir convenu que la rédaction du présente document sera en Anglais, ainsi que tous documents, avis et procédures judiciaires exécutés, donnés ou intentés, à la suite de ou en rapport, directement ou indirectement, avec les procédures concernées.

Graco Information

For more information about InvisiPac, visit www.InvisiPac.com or email InvisiPac@graco.com.

TO PLACE AN ORDER, contact your Graco distributor or call to identify the nearest distributor.

For technical assistance or customer service, call toll free: 1-800-458-2133.

All written and visual data contained in this document reflects the latest product information available at the time of publication. Graco reserves the right to make changes at any time without notice.

Original instructions. This manual contains English. MM

Graco Headquarters: Minneapolis

International Offices: Belgium, China, Japan, Korea

GRACO INC. AND SUBSIDIARIES • P.O. BOX 1441 • MINNEAPOLIS MN 55440-1441 • USA
Copyright 2021, Graco Inc. All Graco manufacturing locations are registered to ISO 9001.

www.graco.com
Revision M, November 2023