

## Intelligent Paint Kitchen

3A4030G  
EN

Used to remotely monitor and control equipment used in a paint kitchen. For professional use only.



### Important Safety Instructions

Read all warnings and instructions in this manual and all related manuals before using the equipment. **Save these instructions.**

*Touchscreen Box and Supervisor Box components shown.*

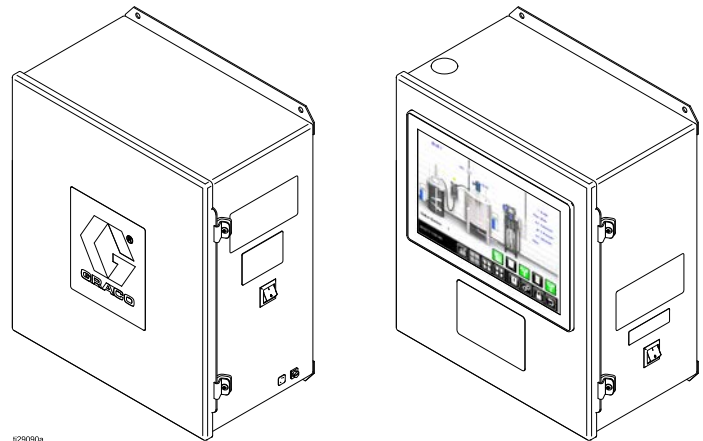

# Contents

Control Components .....	3	Appendix A: System Design .....	150
Component Manuals .....	4	Appendix B: Cables .....	153
Warnings .....	5	Appendix C: Electrical Schematics.....	155
Intelligent Paint Kitchen Overview .....	8	Appendix D: Communication	
Installation and Wiring.....	26	Configuration .....	158
Software Setup.....	45	Allen Bradley PowerFlex.....	158
Touchscreen Software .....	59	Mitsubishi .....	161
Network Setup and Configuration .....	94	Appendix E: Node ID Assignments .....	162
Set Up the Email Server .....	96	Appendix F: Agitator Part Numbers.....	163
Create a Password .....	97	Appendix G: Update the Intelligent Paint Kitchen	
Operation.....	99	Software .....	164
Events and Logs.....	123	Appendix H: Master/Client Setup .....	165
Troubleshooting.....	134	Configure Multiple Displays .....	166
System Software Tasks .....	136	At Power Up .....	167
Repair.....	140	During Normal Operation.....	167
Parts.....	143	Appendix I: VEGAPULS 64 Tank Level Sensor	
Kits and Accessories.....	146	Menu.....	170
Dimensions .....	147	Setup .....	170
Technical Specifications for the Touchscreen		Additional Adjustments.....	176
Box, Supervisor Box, and Expansion		Appendix J: 25E861 - Expandable IO Module	
Box .....	149	Kit .....	178
California Proposition 65.....	149	Installation.....	178
		Troubleshooting .....	179

# Control Components

The following components are described in this manual. For all other components, see the specific component manual.

Part No.	Description	Usage	Operating Voltage	Approvals
25A693	Touchscreen Box	Used to monitor and control functions of the paint kitchen components located inside the hazardous location. The operator uses the Touchscreen interface to view and remotely control conditions and settings.	100–240 VAC	 Intertek 9902741 Conforms to UL STD 508A Certified to CSA STD C22.2 No. 286  Not approved for use in hazardous locations or explosive atmospheres.
25A830	Supervisor Box	Used to communicate between the Pump Control Module, the Tank Control Module, Variable Frequency Drives/Inverters, and the Touchscreen Box. Contains the software controls used to monitor and control paint kitchen components and system performance.	100–240 VAC	
25A843	Expansion Box	One or more Expansion Boxes are needed if the paint kitchen has more components than can fit inside the Supervisor Box 25A830.	100–240 VAC	

# Component Manuals

The following is a list of Graco component manuals written in English. These manuals and any available translations can be found at [www.graco.com](http://www.graco.com).









Manual No.	Description
333389	E-Flo® DC 2-Ball Piston Pumps
3A2096	E-Flo® DC 4-Ball Piston Pumps
3A3384	E-Flo® DC 4-Ball Pumps, Sealed or with Open Wet Cup
3A3453	E-Flo® DC 2000, 3000, and 4000 Circulation Pumps
3A2526	E-Flo® DC Motor
3A4409	E-Flo® DC Motor, Three Phase
3A2527	E-Flo® DC Control Module Kit (Pump Control Module)
3A5991	Tank Control Module Kit
3A5753	Reed Switch (Cycle Count) Kit
406421	Proximity Sensor Accessory Kit
311595	Pneumatic Back Pressure Regulators
3A4548	Electric Driven Back-Gear Drum Agitators
3A4553	Electric Direct Drive Agitator
3A4793	Variable Frequency Drives
313542	Beacon Tower
332196	IS Power Supply Modules
3A5056	G-Barrier Series: Power Barrier for Hazardous Locations
332013	DCM and ADCM



The following component manuals can be found on the manufacturer's website.





Manual No.	Description
SV01N_13418587	Lenze AC Tech, SMVector-Frequency Inverter Operating Instructions
TI01000F	Endress+Hauser Technical Information, Levelflex FMP50 Guided Wave Radar

# Warnings

The following warnings are for the setup, use, grounding, maintenance, and repair of this equipment. The exclamation point symbol alerts you to a general warning and the hazard symbols refer to procedure-specific risks. When these symbols appear in the body of this manual or on warning labels, refer back to these warnings. Product-specific hazard symbols and warnings not covered in this section may appear throughout the body of this manual where applicable. See your component manual for warnings that are specific to those components.

 <h2 style="margin: 0;">WARNING</h2>	
    	<p><b>FIRE AND EXPLOSION HAZARD</b></p> <p>Flammable fumes, such as solvent and paint fumes, in the work area can ignite or explode. Paint or solvent flowing through the equipment can cause static sparking. To help prevent fire and explosion:</p> <ul style="list-style-type: none"> <li>• Use equipment only in a well-ventilated area.</li> <li>• Eliminate all ignition sources such as pilot lights, cigarettes, portable electric lamps, and plastic drop cloths (potential static sparking).</li> <li>• Ground all equipment in the work area. See <b>Grounding</b> instructions.</li> <li>• Never spray or flush solvent at high pressure.</li> <li>• Keep work area free of debris, including solvent, rags, and gasoline.</li> <li>• Do not plug or unplug power cords, or turn power or light switches on or off when flammable fumes are present.</li> <li>• Use only grounded hoses.</li> <li>• Hold gun firmly to side of grounded pail when triggering into a pail. Do not use pail liners unless they are antistatic or conductive.</li> <li>• <b>Stop operation immediately</b> if static sparking occurs or you feel a shock, Do not use equipment until you identify and correct the problem.</li> <li>• Keep a working fire extinguisher in the work area.</li> </ul> <p>Static charge may build up on plastic parts during cleaning and could discharge and ignite flammable vapors. To help prevent fire and explosion:</p> <ul style="list-style-type: none"> <li>• Clean plastic parts only in a well-ventilated area.</li> <li>• Do not operate electrostatic guns in the equipment work area.</li> </ul>
 	<p><b>ELECTRIC SHOCK HAZARD</b></p> <p>This equipment must be grounded. Improper grounding, setup, or usage of the system can cause electric shock.</p> <ul style="list-style-type: none"> <li>• Turn off and disconnect power at main switch before disconnecting any cables and before servicing or installing equipment.</li> <li>• Connect only to a grounded power source.</li> <li>• All electrical wiring must be done by a qualified electrician and comply with all local codes and regulations.</li> </ul>

 <h1 style="margin: 0;">WARNING</h1>	
	<p><b>SKIN INJECTION HAZARD</b></p> <p>High-pressure fluid from dispensing device, hose leaks, or ruptured components will pierce skin. This may look like just a cut, but it is a serious injury that can result in amputation. <b>Get immediate surgical treatment.</b></p> <ul style="list-style-type: none"> <li>• Engage trigger lock when not dispensing.</li> <li>• Do not point dispensing device at anyone or at any part of the body.</li> <li>• Do not put your hand over the fluid outlet.</li> <li>• Do not stop or deflect leaks with your hand, body, glove, or rag.</li> <li>• Follow the <b>Pressure Relief Procedure</b> when you stop dispensing and before cleaning, checking, or servicing equipment.</li> <li>• Tighten all fluid connections before operating the equipment.</li> <li>• Check hoses and couplings daily. Replace worn or damaged parts immediately.</li> </ul>
	<p><b>EQUIPMENT MISUSE HAZARD</b></p> <p>Misuse can cause death or serious injury.</p> <ul style="list-style-type: none"> <li>• Do not operate the unit when fatigued or under the influence of drugs or alcohol.</li> <li>• Do not exceed the maximum working pressure or temperature rating of the lowest rated system component. See <b>Technical Specifications</b> in all equipment manuals.</li> <li>• Use fluids and solvents that are compatible with equipment wetted parts. See <b>Technical Specifications</b> in all equipment manuals. Read fluid and solvent manufacturer's warnings. For complete information about your material, request a Safety Data Sheet (SDS) from your distributor or retailer.</li> <li>• Do not leave the work area while equipment is energized or under pressure.</li> <li>• Turn off all equipment and follow the <b>Pressure Relief Procedure</b> when equipment is not in use.</li> <li>• Check equipment daily. Repair or replace worn or damaged parts immediately with genuine manufacturer's replacement parts only.</li> <li>• Do not alter or modify equipment. Alterations or modifications may void agency approvals and create safety hazards.</li> <li>• Make sure all equipment is rated and approved for the environment in which you are using it.</li> <li>• Use equipment only for its intended purpose. Call your distributor for information.</li> <li>• Route hoses and cables away from traffic areas, sharp edges, moving parts, and hot surfaces.</li> <li>• Do not kink or over bend hoses or use hoses to pull equipment.</li> <li>• Keep children and animals away from work area.</li> <li>• Comply with all applicable safety regulations.</li> </ul>

 <h1 style="margin: 0;">WARNING</h1>	
 	<p><b>MOVING PARTS HAZARD</b>                      Moving parts can pinch, cut, or amputate fingers and other body parts.</p> <ul style="list-style-type: none"> <li>• Keep clear of moving parts.</li> <li>• Do not operate equipment with protective guards or covers removed.</li> <li>• Pressurized equipment can start without warning. Before checking, moving, or servicing equipment, follow the <b>Pressure Relief Procedure</b> and disconnect all power sources.</li> </ul>
	<p><b>PERSONAL PROTECTIVE EQUIPMENT</b>                      Wear appropriate protective equipment when in the work area to help prevent serious injury, including eye injury, hearing loss, inhalation of toxic fumes, and burns. This equipment includes but is not limited to:</p> <ul style="list-style-type: none"> <li>• Protective eyewear and hearing protection.</li> <li>• Respirators, protective clothing, and gloves as recommended by the fluid and solvent manufacturer.</li> </ul>

## **Intelligent Paint Kitchen Overview**

The Intelligent Paint Kitchen (also known as IPK) is a platform of compatible sensors, controllers, pumps, agitators, and communication components that can be combined to create a customized paint circulation system. The Intelligent Paint Kitchen covers components that are installed inside two types of physical space, hazardous and non-hazardous locations:

- The fluid handling components and control components are located in one or more hazardous locations, typically one station for each paint color.
- The remote monitoring and control components are located in a non-hazardous location, up to 1000 feet (330 meters) away from the fluid handling components.

Sensors continuously monitor conditions within the fluid circulation system. Typically data such as tank level, agitator speed, pressure at one or more locations, and flow rate is collected from each station and sent to a Pump Control Module, which is attached to each agitator and pump. The Pump Control Module and Tank Control Module allow local control and provide remote monitoring and control of components using a single optical fiber connection. Settings programmed into the Supervisor Module and Touchscreen Module display the current conditions and allow users to adjust the conditions from a remote location.

Each Intelligent Paint Kitchen installation is unique. Station components are selected and sized according to your requirements. Some controls and sensors are optional, and any system can be configured to provide the necessary controls, locally and remotely.



### Component Identification

This section describes the components in a typical Intelligent Paint Kitchen system containing one station.

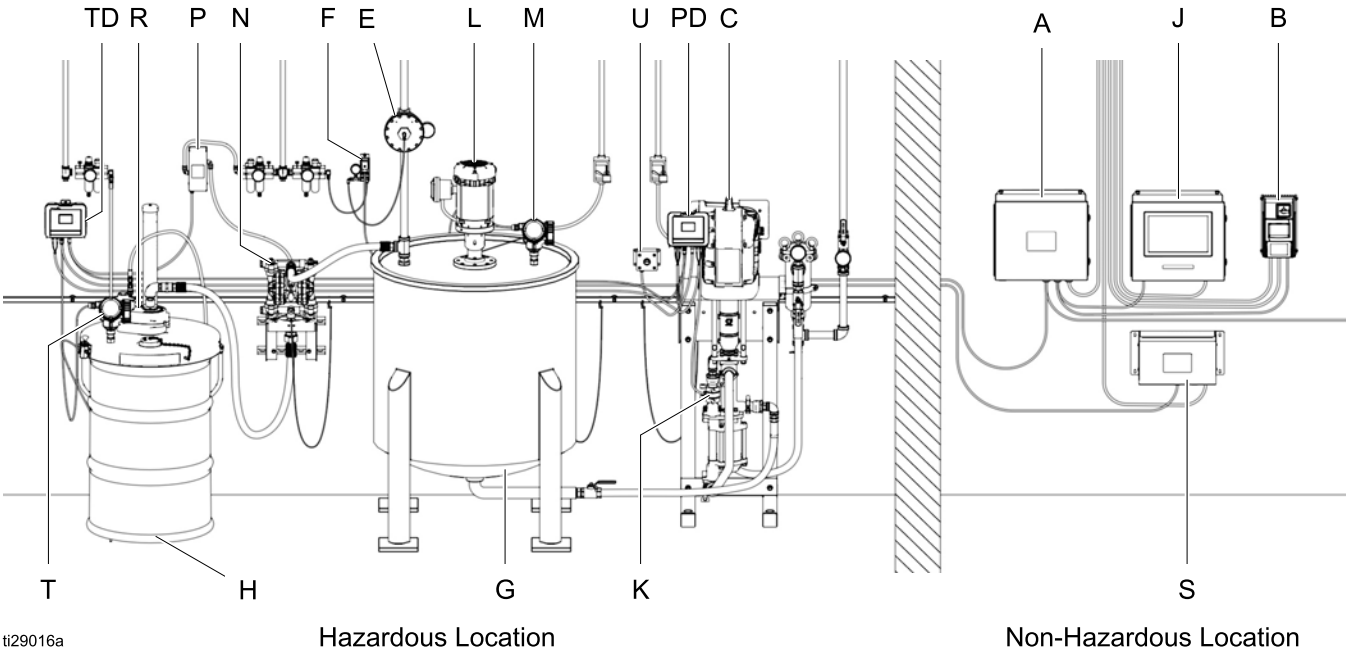

ti29016a

Figure 1 Intelligent Paint Kitchen System with One Fluid Station, One Pump, and Two Tanks (Typical Installation)

Table 1 Component Identification

Ref.	Component	Description
A	<a href="#">Supervisor Box, page 18</a>	<p>Contains the communications hub for the Intelligent Paint Kitchen. It must be installed in a non-hazardous location.</p> <p>The Supervisor Box facilitates communication between the Pump Control Module (PD) in the hazardous location and the Touchscreen Box (J) or a Programmable Logic Controller (also known as PLC). The Supervisor Box converts information from the Graco Touchscreen Box (J) or Programmable Logic Controller into fiber optic signals used by the system components.</p> <p>One Supervisor Box can control up to 10 stations (20 if an Expansion Box is used). Each station is connected to the Supervisor Box with a pair of optical fiber cables.</p>
B	<a href="#">Variable Frequency Drive/Inverter, page 17</a>	<p>Controls the speed of an electric agitator. It must be installed in a non-hazardous location.</p> <p>One Variable Frequency Drive/Inverter is needed for each electric agitator. The Variable Frequency Drive/Inverter communicates with the Supervisor Box (A) using a RS-485 cable connection.</p>
C	<a href="#">E-Flo DC Pump, page 12</a>	<p>An electric circulation pump for use in the hazardous location. It can be a single or double E-Flo DC pump.</p> <p>For Intelligent Paint Kitchen communication, the pump must be an advanced model with a Pump Control Module (PD) and communication capability required for connection to the Supervisor Module, located in the Supervisor Box (A).</p>

Ref.	Component	Description
E	Back Pressure Regulator, page 14	Installed in the fluid return line. Also known as the BPR, it is controlled pneumatically to maintain fluid pressure in the fluid circulation system.
F	Back Pressure Regulator Controller, page 14	Allows control of the Back Pressure Regulator (E), either locally using the Pump Control Module (PD) or remotely using the Touchscreen Box (J).
G	Primary Tank	Provides fluid for the paint kitchen. The Primary Tank is kept filled with a controlled amount of fluid, filled as needed from the Secondary Tank (H) and constantly stirred by the Agitator (L). As fluid is pumped through the paint kitchen, fluid is continuously drawn from and returned back to this tank.
H	Secondary Tank	Contains the fluid used to fill the Primary Tank (G) as needed. Must be manually refilled or replaced when empty. The tank or drum may have an Agitator (R) and Radar Level Sensor (T) installed for communication with the Intelligent Paint Kitchen software.
J	Touchscreen Box, page 21	A user interface for setup, operation, and monitoring of system devices. It must be installed in a non-hazardous location.  The Touchscreen Box can be connected to a Supervisor Box (A). It communicates with the Supervisor Box using Modbus TCP.
K	Pressure Transducers (Sensors), page 13	One or two Pressure Transducers may be installed to measure the pressure inside the paint kitchen circulation lines. Each Pressure Transducer communicates with the Supervisor Box (A), which monitors the pressure and controls the E-Flo DC Pump (C) to maintain the fluid pressure of the fluid leaving the pump. The Pressure Transducer can monitor pressure at the pump outlet, at the Back Pressure Regulator (E), or both.
L	Agitator (Primary Tank), page 16	Continuously mixes and stirs the contents, preventing fluid from separating, setting, or drying on the inside of the tank. This agitator can be either a Graco electric agitator or a user-supplied agitator.  If an electric agitator is used, an additional Variable Frequency Drive/Inverter (B) is needed to control the agitator speed.
M	Radar Level Sensor (Primary Tank), page 15	Detects and communicates the fluid level in the Primary Tank (G).
N	Pneumatic Remote Transfer Fill Pump	Air-operated double diaphragm pump for use in the hazardous location. Its purpose is to fill the Primary Tank (G) from the Secondary Tank (H), as needed.
P	Fill Pump Transfer Solenoid, page 16	Activates the Pneumatic Remote Transfer Fill Pump (N) whenever fluid in the Primary Tank (G) falls below the level specified in the Intelligent Paint Kitchen software. When the Primary Tank is filled to the user-specified level, the pump shuts off.
PD	Pump Control Module, page 13	Intrinsically safe control module with user interface for use in the hazardous location. One is needed for each E-Flo DC pump (C). The Pump Control Module connects to the pump and pump-related components. It provides the communication connection between the station and the Supervisor Box (A). Connects to the Supervisor Box by a pair of fiber optic cables.

Ref.	Component	Description
R	Agitator (Secondary Tank), page 16	Continuously mixes and stirs the contents, preventing fluid from separating, setting, or drying on the inside of the tank. This agitator can be either a Graco electric agitator or a user-supplied agitator.  If an electric agitator is used, an additional Variable Frequency Drive/Inverter (B) is needed to control the agitator speed.
S	DC Power Supply With Barrier	Powers the Tank Control Module (TD). It must be installed in a non-hazardous location.  Electric power to each Tank Control Module requires a separate barrier.
T	Radar Level Sensor (Secondary Tank), page 15	Detects and communicates the fluid level in the Secondary Tank (H).
TD	Tank Control Module, page 15	Intrinsically safe control module with user interface for use in the hazardous location. One is needed for each Secondary Tank (H) that uses an electric agitator (R) or Radar Level Sensor (T). The Tank Control Module connects to related components in the hazardous location and to the Pump Control Module (PD), providing a communication connection between the station and the Supervisor Box (A).
U	Run/Stop Switch, page 14	When installed, stops or pauses the E-Flo DC Pump (C) during operation. The Run/Stop Switch does not disconnect power to the pump, but it does stop or pause the pump.
X	Reed Switch (not shown), page 14	Ensures that the Primary Tank (G) does not get overfilled. If the Pneumatic Remote Transfer Fill Pump (N) is running but the fluid level in the Primary Tank is not changing, the Reed Switch signal causes the Intelligent Paint Kitchen software to shut down the pump.
—	Expansion Box (not shown), page 20	Provides room for extra serial to fiber optic converters, once the main Supervisor Box (A) is full. It must be installed in a non-hazardous location.  The Expansion Box can hold an additional 12 fiber optic converters.

## E-Flo DC Pump (C)

Each station can contain one E-Flo DC pump (C). The pump's job is to continuously circulate a specific paint color through the paint kitchen, making that color available for spraying. Each E-Flo DC pump maintains a constant fluid pressure or flow rate within the system.

Pump pressure sensors and flow sensors connect to the Pump Control Module (PD). Each pump can be locally controlled using its Pump Control Module. See [Pump Control Module \(PD\) 24P822, 17V232, page 13](#).

To set up connections to the E-Flo pump, see [Connections to the E-Flo DC Pump, page 27](#). For complete warnings and operation instructions, see the following manuals:

- E-Flo DC 2-Ball Piston Pump manual 333389
- E-Flo DC 4-Ball Piston Pump manual 3A2096
- E-Flo DC 4-Ball Pump manual 3A3384

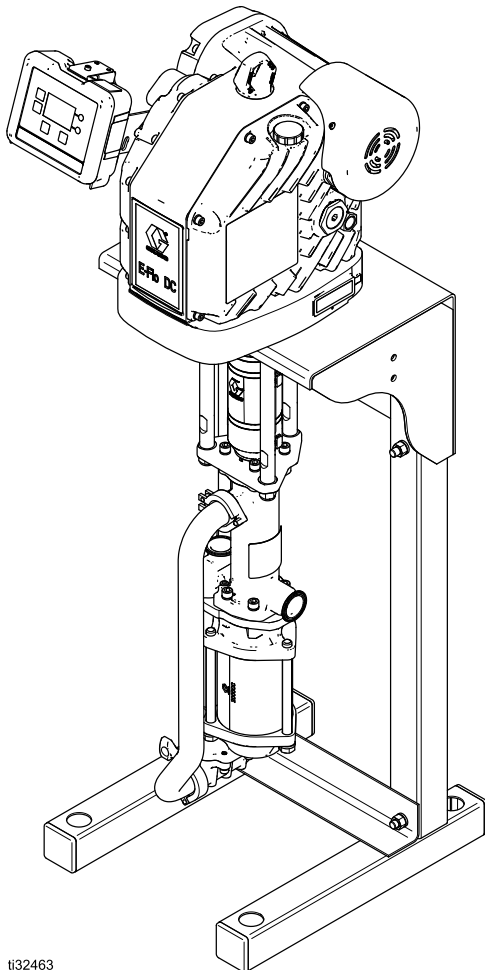

ti32463

Figure 2 E-Flo DC Pump with Pump Control Module

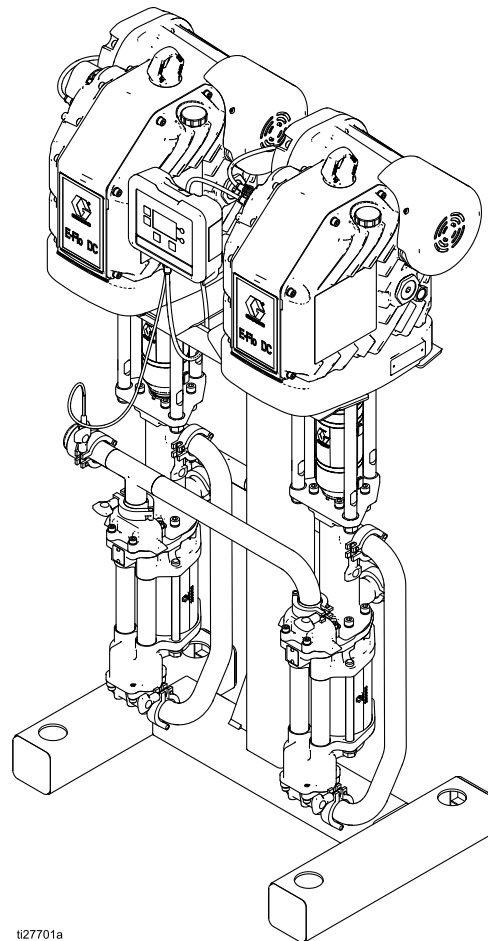

ti27701a

Figure 3 E-Flo DC 2000, 3000, or 4000 High Volume Pump with Pump Control Module

## Pump Control Module (PD) 24P822, 17V232

The Pump Control Module (PD) is a Modbus RTU node in the station. Each Pump Control Module is wired using a pair of fiber optic cables to a fiber optic converter installed inside a Supervisor Box (A).

All communications between components on the non-hazardous location and the hazardous location sides pass to or from the Pump Control Module along the fiber optic connection.

The Pump Control Module serves as the connection point and power source for other paint kitchen components, including the Radar Level Sensor (M, T), Fill Pump Transfer Solenoid (P), and Back Pressure Regulator Controller (F).

Power to the Pump Control Module is supplied by the E-Flo DC pump (C). Each Pump Control Module has its own software installed to send instructions from the Intelligent Paint Kitchen software to the connected components, and to send signals from those components back to the Intelligent Paint Kitchen software.

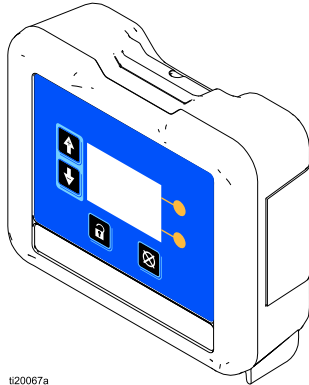

Figure 4 Pump Control Module

For information on connecting cables to the correct ports for pump control, see the cable connection section of the DC Control Module Kit manual 3A2527 and [Set Up Pump Control Module Configurable I/O, page 50](#) in this manual. See the DC Control Module Kit manual 3A2527 for complete warnings and operation instructions.

## Pressure Transducer (K) 24R050, 24X089

Install the Pressure Transducer (K) using one of the following kits:

- 24R050: Pressure Transducer, NPT
  - 24X089: Pressure Transducer, Inline Tri-Clamp
1. To measure fluid pressure, install the Pressure Transducer in the fluid line with a tee fitting.
    - If closed loop control is enabled on Setup Screen 8 (transducer 1) or Setup Screen 9 (transducer 2), install the transducer near the pump outlet, not near the end of the circulation line.
    - If closed loop control is not enabled on Setup Screen 8 (transducer 1) or Setup Screen 9 (transducer 2), install the transducer where needed.
  2. Connect the transducer cable to Port 7 (transducer 1) or Port 10 (transducer 2) on the Pump Control Module (PD) or Tank Control Module (TD).

## Back Pressure Regulator (E) and Controller (F) 24V001

Paint returning to the Primary Tank (G) passes through the pneumatic Back Pressure Regulator (E), which maintains the pressure in the paint circulation system.

The pressure setting is controlled using the profile setting in the Pump Control Module (PD). The Back Pressure Regulator setting can change automatically whenever a different pump profile is selected.

Install a Back Pressure Regulator Controller 24V001 (F) in the hazardous location to provide intrinsically safe control of the back pressure regulator. The Back Pressure Regulator Controller automatically controls input air pressure to maintain the fluid system back pressure as specified in the pump control software. Signals to and from the Back Pressure Regulator Controller pass through the Pump Control Module, allowing for closed loop pressure control in the circulation line. For complete warnings and operation instructions, see the Pneumatic Back Pressure Regulator manual 311595.

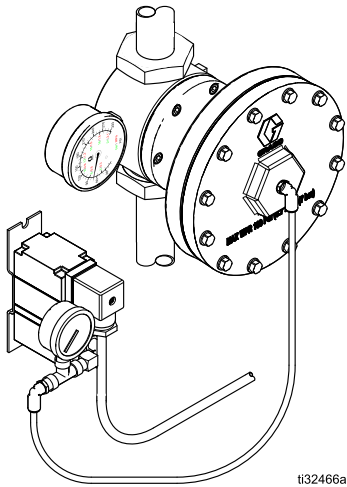

Figure 5 Back Pressure Regulator and Controller

## Run/Stop Switch (U) 16U729

Install the Run/Stop Switch (U) using the Run/Stop Switch Kit 16U729.

1. Mount the switch near the Pump Control Module (PD), using the bracket provided.
2. Connect the switch cable to Port 4 on the Pump Control Module (PD).

For complete warnings and operation instructions, see the E-Flo DC Control Module Kit manual 3A2527.

## Reed Switch (X) 17W772, 241405

Install the Reed Switch (X).

- For Husky 515 and 716 models, use Reed Switch (Cycle Count) Kit 241405. For complete warnings and operation instructions, see the Proximity Sensor Accessory Kit manual 406421.
- For Husky 1050 models, use Reed Switch (Cycle Count) Kit 17W772. For complete warnings and operation instructions, see the Reed Switch (Cycle Count) Kit manual 3A5753.

## Tank Control Module (TD) 17S843

A Tank Control Module (TD) is needed for a station that has a Secondary Tank (H) with level monitoring. The Tank Control Module does the following:

- Provides the electrical power and the I/O connections needed to operate two tank Radar Level Sensors (M, T), agitator speeds, and transfer pump logic
- Monitors and provides real time tank level information to the Intelligent Paint Kitchen software
- Controls agitator motor speed
- Turns the Fill Pump Transfer Solenoid (P) on and off to keep the Primary Tank (G) filled to the correct level

Electrical power to the Tank Control Module comes from the DC Power Supply with Barrier (S) located in the non-hazardous location.

Within a paint kitchen, the Tank Control Module is connected directly to the Pump Control Module (PD) with a pair of fiber optic cables. All signals to and from the Tank Control Module pass through the Pump Control Module. A Tank Control Module is needed in a system that has no Pump Control Module. Connect the Tank Control Module to a fiber optic converter in the Supervisor Box (A).

**NOTE:** The Pump Control Module and Tank Control Module look identical to each other, but they are not interchangeable. Each type of control module has its own unique software installed.

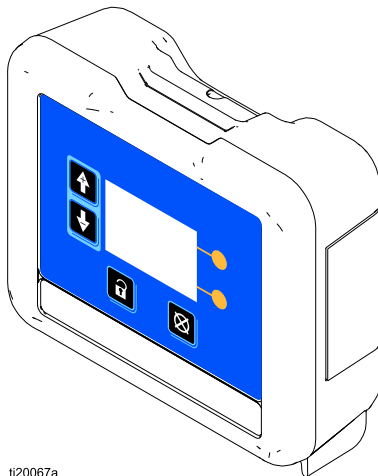

Figure 6 Tank Control Module

For complete warnings and operation instructions, see the Tank Control Module manual 3A5991.

## Radar Level Sensor (M, T) 25D293, 25D294

**NOTE:** See [Appendix I: VEGAPULS 64 Tank Level Sensor Menu, page 170](#), for information about the VEGAPULS 64 Sensor.

A Radar Level Sensor (M, T) is used to monitor the level of material inside the tank.

- 25D293 - Contains an Endress+Hauser™ FMP50™ wave-guided radar sensor with FM approval.
- 25D294 - Contains an Endress+Hauser™ FMP50™ wave-guided radar sensor with ATEX and IECEx approval.

For complete warnings, approvals, and operation instructions, see the manufacturer's manual (supplied).

A digital display allows the current level to be read locally.

Suitable Radar Level Sensors may be obtained from various manufacturers.

The Radar Level Sensor software communicates tank level data to the Pump Control Module (PD) or Tank Control Module (TD), which can be set to turn on the Pneumatic Remote Transfer Fill Pump (N) to refill the tank when needed.

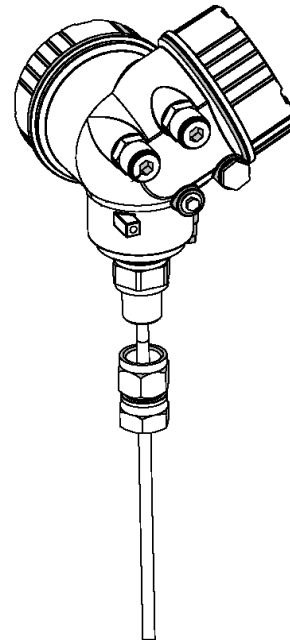

Figure 7 Radar Level Sensor

## Fill Pump Transfer Solenoid (P) 24Z671

The Fill Pump Transfer Solenoid (P) engages the Pneumatic Remote Transfer Fill Pump (N) when the fluid level in the Primary Tank (G) falls below a user-specified level. The solenoid disengages the pump when the fluid level rises to a user-specified level.

The Fill Pump Transfer Solenoid contains a MAC™ valve that carries FM, ATEX, and IECEx approvals.

### Connections:

- The air inlet connects to a user-provided source of air pressure.
- The air outlet connects to the Pneumatic Remote Transfer Fill Pump.

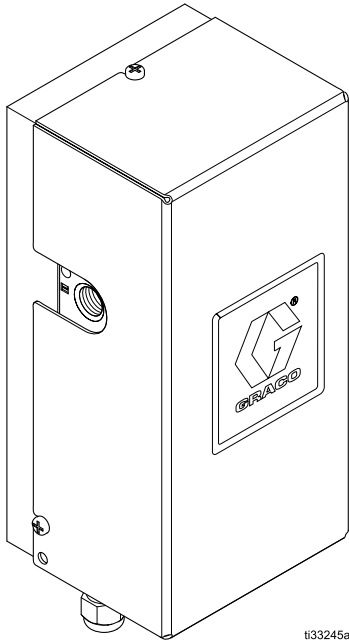

## Agitator (L, R)

One agitator (L, R) is typically mounted on each tank. The agitator's purpose is to keep the fluid mixed, without incorporating air into the fluid.

Each agitator may be electric or pneumatic; however, the Intelligent Paint Kitchen system can only communicate with an electric agitator.

An electric agitator's speed is controlled by a Variable Frequency Drive/Inverter (B). Every Variable Frequency Drive/Inverter is mounted in the non-hazardous location, but the Intelligent Paint Kitchen system allows the speed to be controlled locally with the Pump Control Module (PD) or the Tank Control Module (TD). For complete warnings and operation instructions, see the agitator manual.

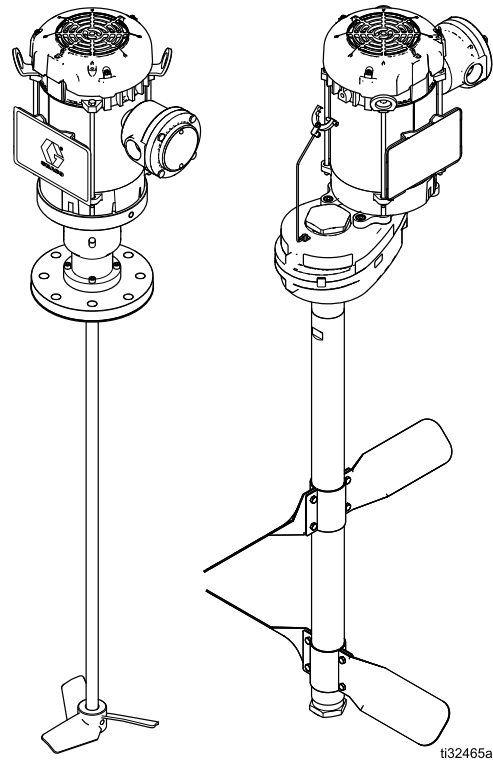

Figure 8 Agitator (electric direct drive and back-gear models shown)



**Variable Frequency Drive/Inverter (B)  
17N041, 17N042, 17N043**

The Variable Frequency Drive/Inverter (B) controls the speed of an AC electric agitator. Suitable Variable Frequency Drives/Inverters may be obtained from Graco or from a variety of manufacturers. Supported Variable Frequency Drive/Inverter manufacturers include Lenze SMVector and Allen Bradley PowerFlex 4M.

Model	Input	Output	HP
17N041	120–240 VAC (single phase)	240 VAC (three phase)	1
17N042	208–240 VAC (single or three phase)	208–240 VAC (three phase)	1
17N043	380–480 VAC (three phase)	380–480 VAC (three phase)	1

One Variable Frequency Drive/Inverter is needed for each electric agitator in the system. Software installed in each Variable Frequency Drive/Inverter allows communication between each Variable Frequency Drive/Inverter and the Supervisor Box (A). Warnings, installation, and operation details are contained in the provided Variable Frequency Drive/Inverter manual.

Variable Frequency Drives/Inverters are not approved for use in hazardous locations. They must be installed in the non-hazardous location of the Intelligent Paint Kitchen. For complete warnings and operation instructions, see the Variable Frequency Drives manual 3A4793.

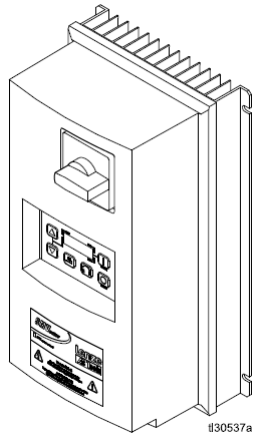

Figure 9 Variable Frequency Drive/Inverter

**DC Power Supply With Barrier (S)  
26C724**

The DC Power Supply with Barrier (S) provides 15 VDC power to all Tank Control Modules (TD) in the system. The power supply must be installed in the non-hazardous location and is connected to the Tank Control Modules with intrinsically safe power cables.

This power supply has enough barriers to power three Tank Control Modules (TD). If more power barriers are required, additional power supplies will be needed.

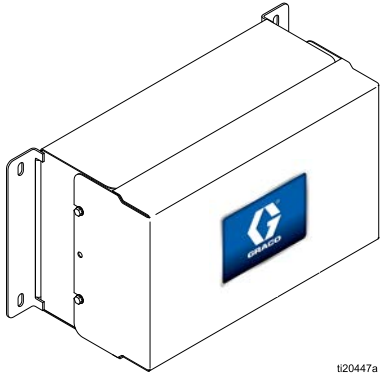

Figure 10 DC Power Supply with Barrier

## Supervisor Box (A) 25A830

As shipped, the Supervisor Box (A) contains the Supervisor Module (36), power supply, switch, Ethernet switch, and one fiber optic converter. Install additional fiber optic converters as needed, one for each station.

Installed inside each Supervisor Box, the Supervisor Module contains the software that runs the Intelligent Paint Kitchen. The Supervisor Module communicates with Pump Control Modules (PD), Tank Control Modules (TD), and Variable Frequency Drives/Inverters (B) using Modbus RTU. The Supervisor Module sets up a Modbus addressing

data table to create a large datamap with each node slotted in a specific set of addresses.

The Supervisor Box can communicate via Modbus TCP with the Touchscreen Box (J).

The Supervisor Module can manage up to 20 stations. Up to 10 fiber optic converters can fit in the Supervisor Box. If additional fiber optic converters are needed beyond what fits in the Supervisor Box, an Expansion Box can be used to create more space. See [Expansion Box 25A843, page 20](#).

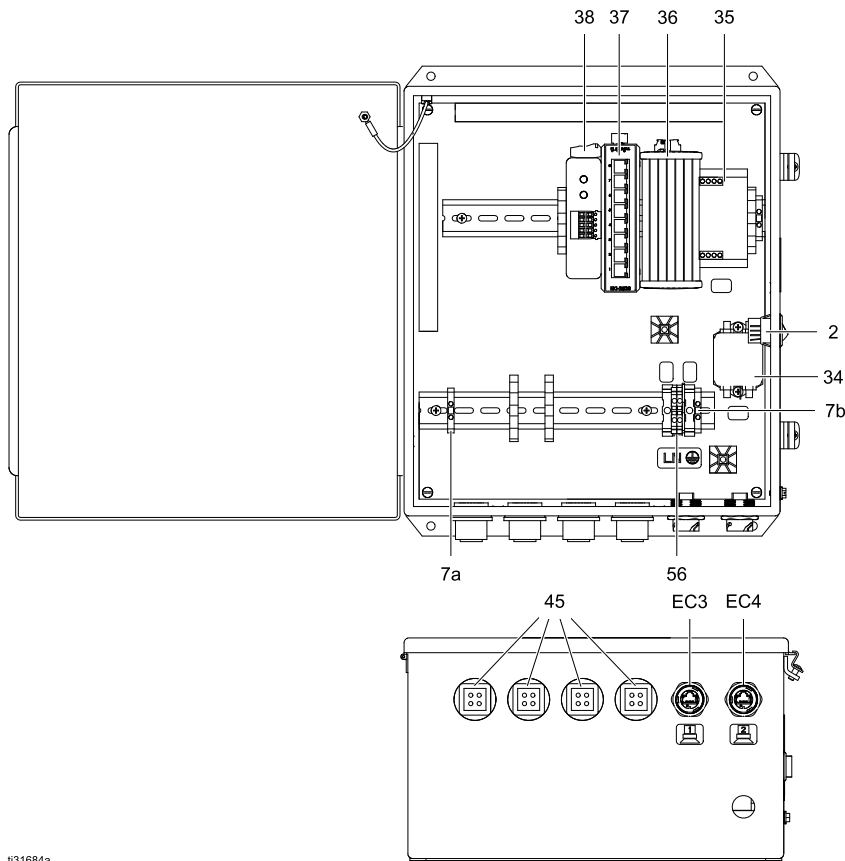

131684a

Figure 11 Supervisor Box Components

Ref	Function
2	Power Rocker Switch
7a	EMC Ground Terminal
7b	Protective Earth Ground Terminal
34	Power Line Filter
35	Power Supply Unit, 2 amp, 24 VDC
36	Supervisor Module

37	Ethernet, eight port switch
38	<a href="#">Serial to Fiber Optic Converter, page 19</a>
45	Strain Relief
56	Terminal Block
EC3	Ethernet Connector 1 (network connection)
EC4	Ethernet Connector 2 (connect to Touchscreen Box)

**Fiber Optic Converter  
24N978**

Installed inside the Supervisor Box (A) and the Expansion Box, each serial to fiber optic converter sends data to and receives data from one Pump Control Module (PD) installed in the hazardous location of a station.

Data is sent to and from the Pump Control Module (PD) along a fiber optic cable. A serial cable connection is made between each fiber optic converter and the Supervisor Module, and the fiber optic converters within one Supervisor Box or one Expansion Box are all wired in series to the 24 VDC power supply.

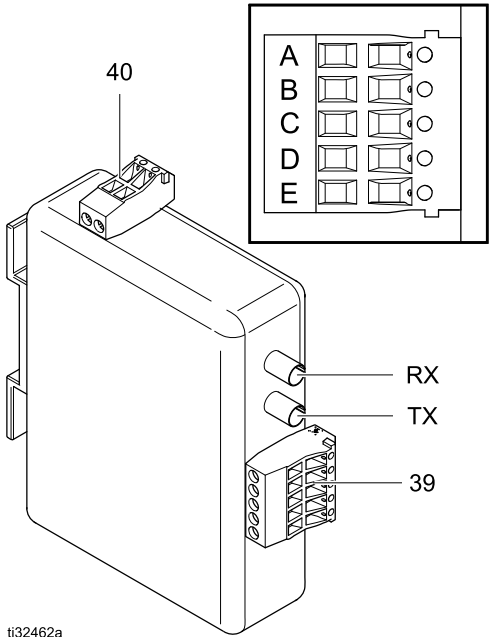

Figure 12 Serial to Fiber Optic Converter

Item	Description
39	Serial communication connection to Supervisor Module
40	24 VDC power connection
RX	Fiber optic cable connection; receives data from a Pump Control Module
TX	Fiber optic cable connection; transmits data to a Pump Control Module
A	Ground
B	Terminal Data B (+)
C	Terminal Data A (-)
D	Terminal D (not used)
E	Terminal E (not used)

## Expansion Box 25A843

Use an Expansion Box when your system requires more fiber optic converters than can fit in the Supervisor Box (A). Each Supervisor Box may be connected directly to one Expansion Box to connect to a maximum of 20 stations (7 or 10 fiber optic converters in the Supervisor Box, and up to 12 fiber optic converters in the Expansion Box).

The Expansion Box has a DC power supply installed to provide power to the fiber optic converters.

Expansion Boxes are shipped with one fiber optic converter (38) installed. Each box also contains one power supply (35), and one Supervisor Module (36).

Install up to 12 fiber to optic converters (38) in each Expansion Box needed by the system.

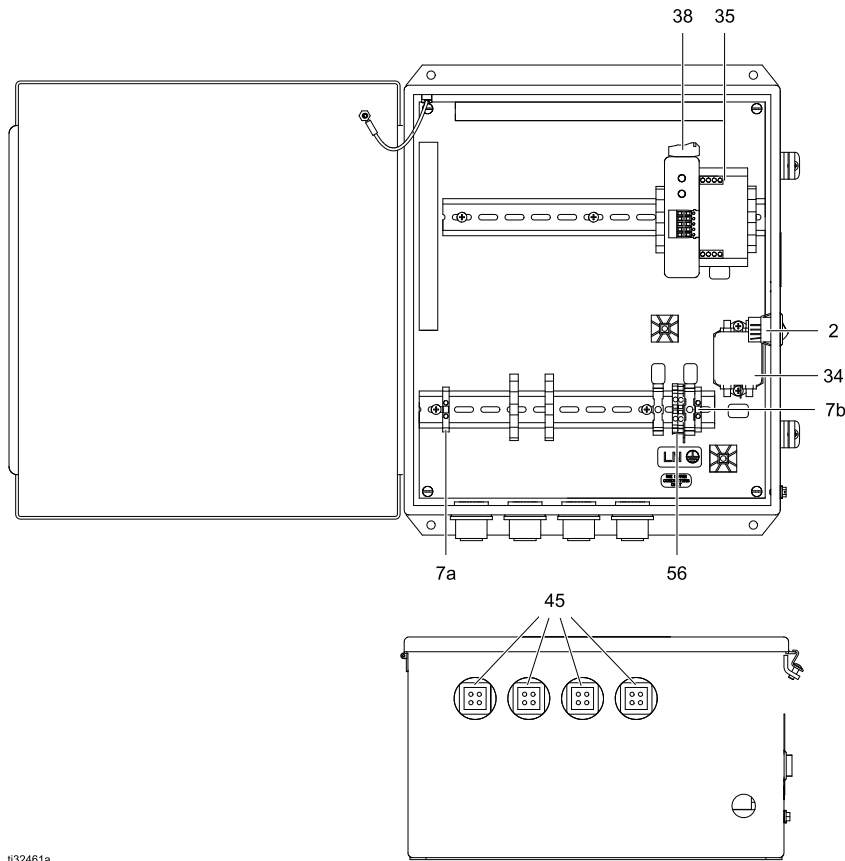

032461a

Figure 13 Expansion Box Components

Ref	Function
2	Power rocker switch
7a	EMC ground terminal
7b	Protective earth ground terminal
34	Power line filter
35	Power supply unit, 2 amp, 24 VDC
38	Serial to fiber optic converter
45	Strain relief
56	Terminal Block

## Touchscreen Box (J) 25A693

The Touchscreen Box (J) is an optional component in the Intelligent Paint Kitchen. The Touchscreen Box allows the user to do the following remotely:

- Set up the system before use and configure the paint kitchen components to communicate with each other
- Display current paint kitchen conditions and settings for remote monitoring and control
- Control paint kitchen components and change operating conditions

A 2 GB SD flash card can be used to install and update the software used by the Touchscreen Box. The SD card must be formatted using the FAT16 file system.

A USB cable can be connected to download the stored log files generated by the Intelligent Paint Kitchen system.

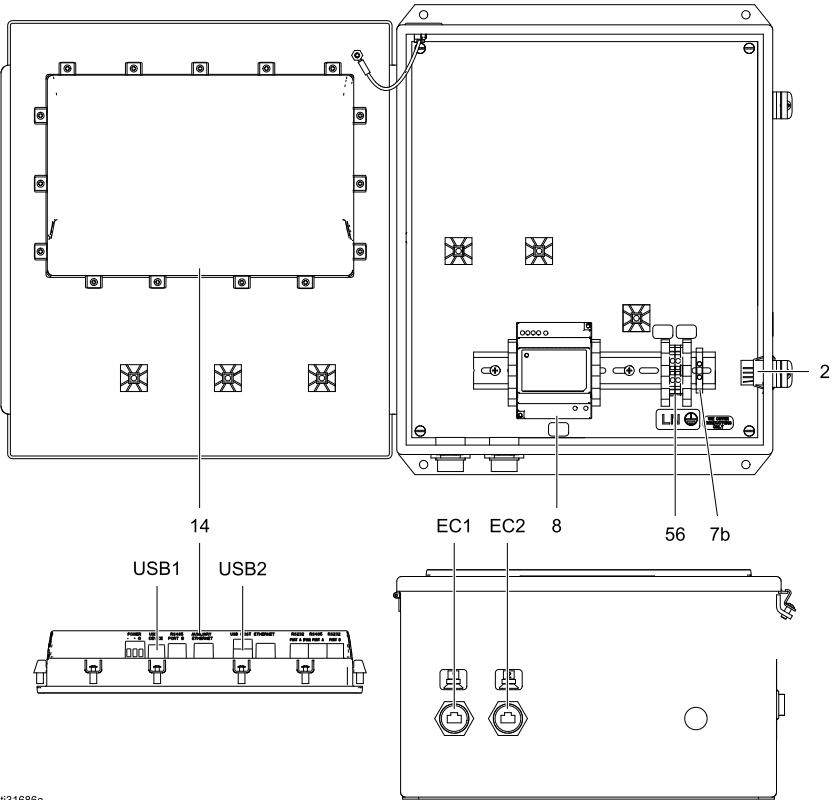
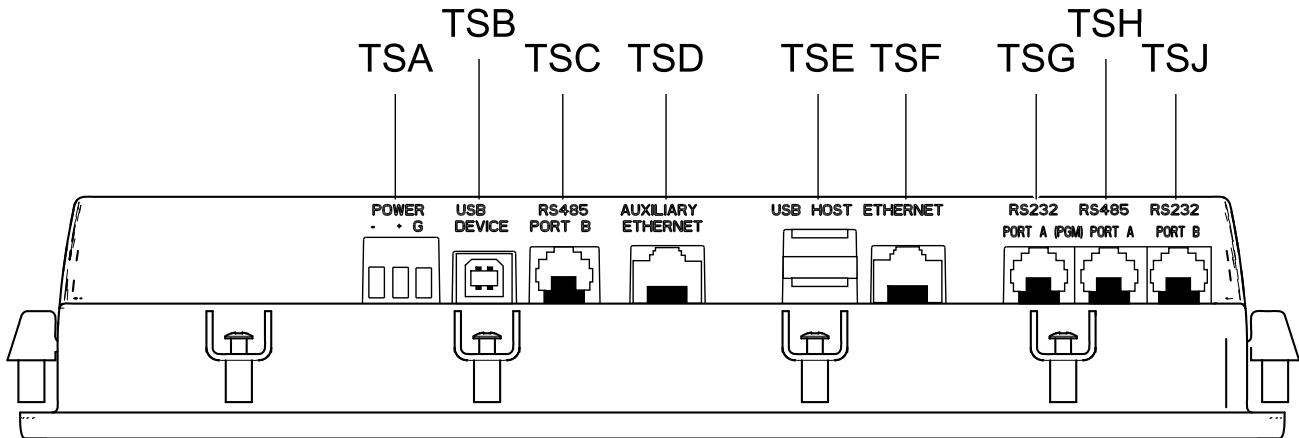

Figure 14 Touchscreen Box Components

Ref	Function
2	Power rocker switch
7b	Protective earth ground terminal
8	Power supply, 24 VDC
14	Touchscreen control module
56	Terminal block
EC1	Ethernet connector 1 – network connection
EC2	Ethernet connector 2 – connect to Supervisor Box
USB1	USB cable for PC
USB2	USB jump drive

**Touchscreen Box Connections**

Power and communication connections are made using the ports located along the bottom of the Touchscreen Box.



ti34219a

Figure 15 Touchscreen Box Connections

Ref.	Function
TSA	Power
TSB	USB device connection for PC (USB B)
TSC	RS-485 Port B (not used)
TSD	Auxiliary Ethernet (Port 2) Modbus/TCP connection
TSE	USB host connection for jump drive
TSF	Ethernet (Port 1) LAN
TSG	RS-232 Port A (PGM) (not used)
TSH	RS-485 Port A (not used)
TSJ	RS-232 Port B (not used)

### Examples of Component Connections

The following diagrams illustrate different ways to connect Intelligent Paint Kitchen components. Use the diagram that corresponds to the components used in your station.

Connect each of the lettered components to the corresponding lettered port on the Pump Control Module (PD) or Tank Control Module (TD), as shown.

When connecting multiple components to Port 4 of either control module, use a cable splitter (17R629) to make the connections.

#### Connections in a System with One Pump Control Module and No Tank Control Module

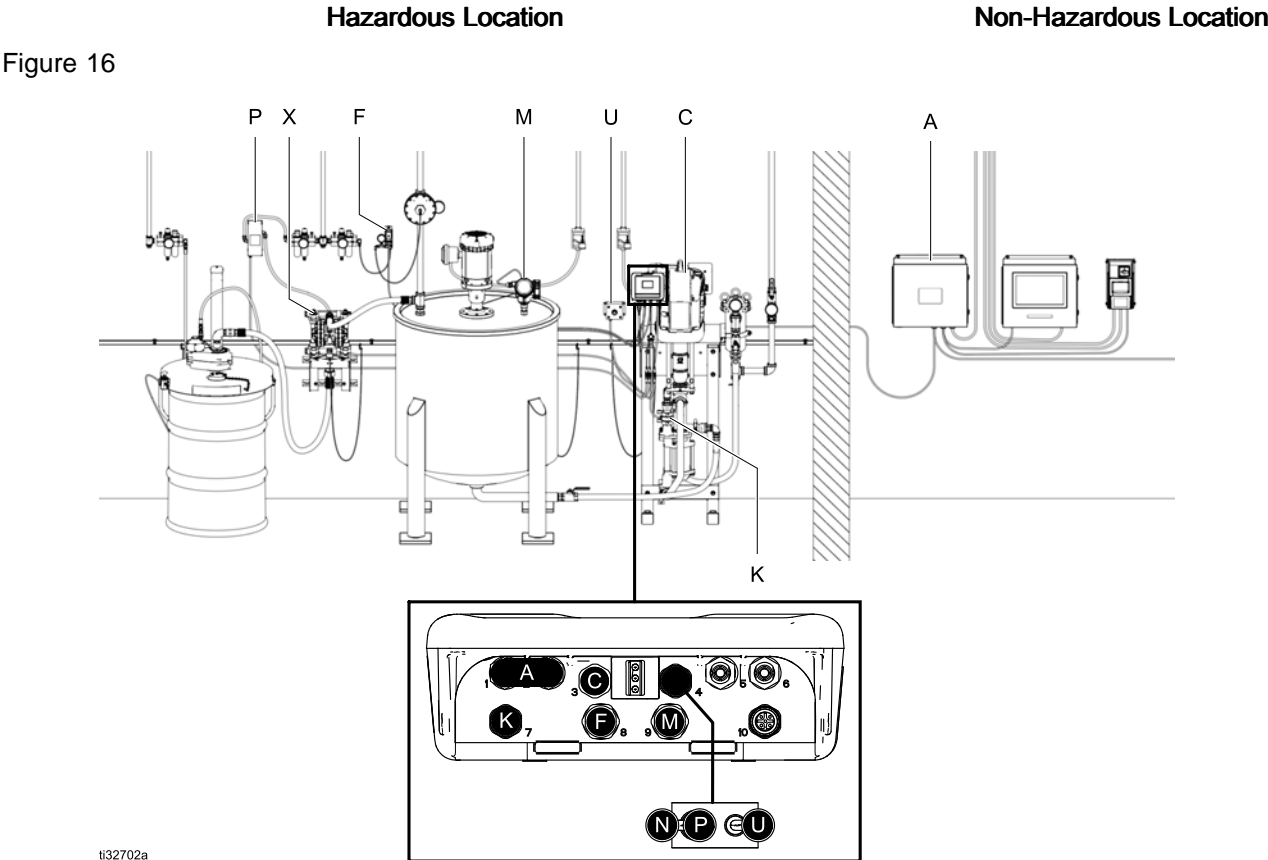

Figure 16

1132702a

Ref.	Component
A	Supervisor Box (fiber optic converter)
C	Pump (E-Flo DC shown)
F	Back Pressure Regulator Controller
K	Pressure Transducer
M	Primary Tank Radar Level Sensor
P	Fill Pump Transfer Solenoid
U	Run/Stop Switch for E-Flo DC
X	Reed Switch for Cycle Monitoring

Connections in a System with No Pump Control Module and One Tank Control Module

Hazardous Location

Non-Hazardous Location

Figure 17

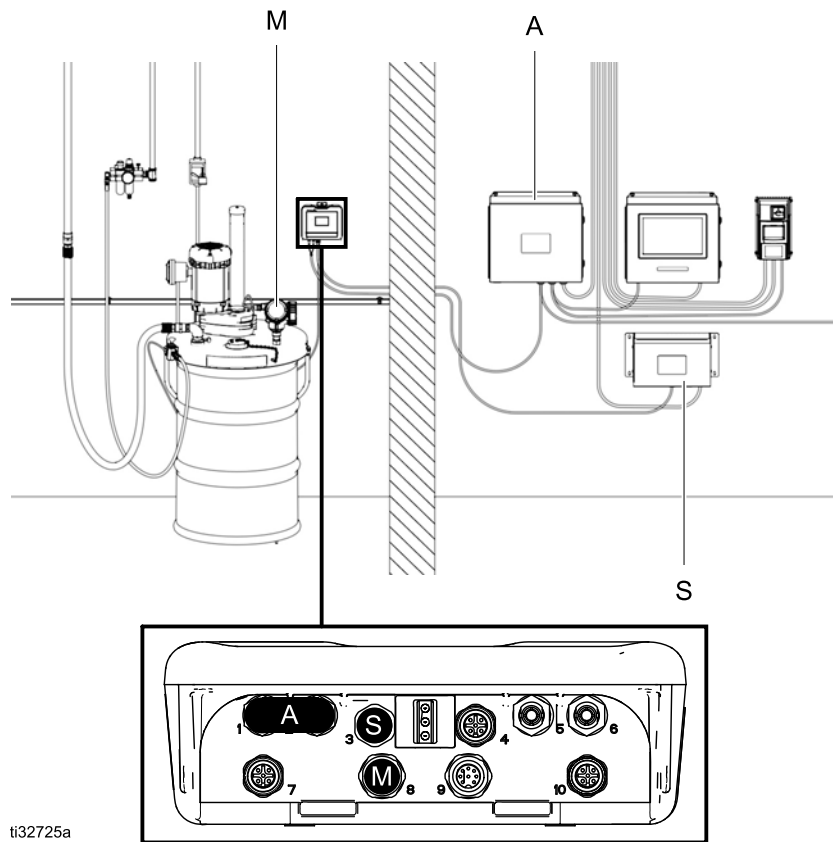

ti32725a

Ref.	Component
A	Supervisor Box (fiber optic converter)
M	Primary Tank Radar Level Sensor
S	DC Power Supply with Barrier



Connections in a System with One Pump Control Module and One Tank Control Module

Hazardous Location

Non-Hazardous Location

Figure 18

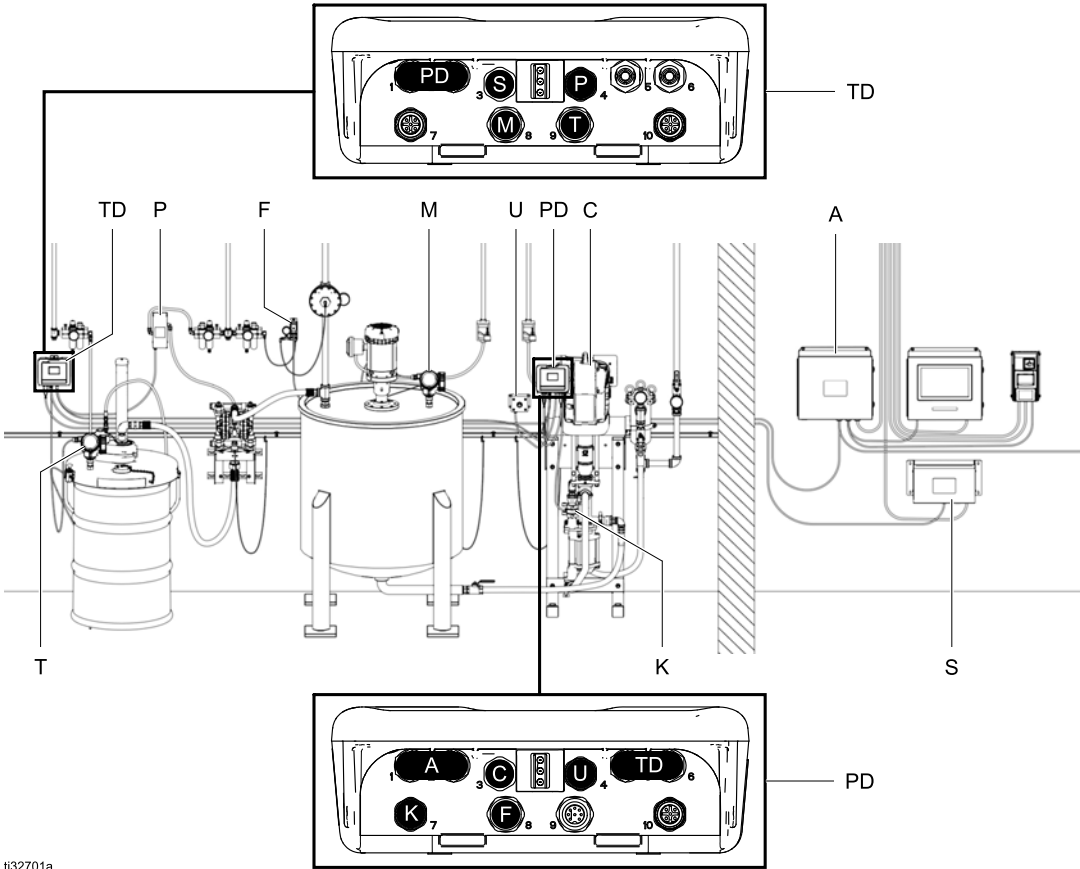

ii32701a

Ref.	Component
A	Supervisor Box (fiber optic converter)
C	Pump (E-Flo DC shown)
F	Back Pressure Regulator Controller
K	Pressure Transducer
M	Primary Tank Radar Level Sensor
P	Fill Pump Transfer Solenoid
PD	Pump Control Module
S	DC Power Supply with Barrier
T	Secondary Tank Radar Level Sensor
TD	Tank Control Module
U	Run/Stop Switch for E-Flo DC

# Installation and Wiring

				
To reduce the risk of fire, explosion, or electric shock, only install equipment in a hazardous location if the equipment is approved for a hazardous location.				

## Planning the Installation

Installation of the Intelligent Paint Kitchen must be carefully planned before ordering the system. The number of stations must be known. The location, size, and type of each component must be taken into account to ensure that the correct number of Supervisor Boxes, fiber optic converters, Variable Frequency Drives/Inverters, and cables are on hand, and that pneumatic and electrical power are available for all devices in the system.

Be sure you know the distance between each pump and the planned location of the components located in the non-hazardous location so the optical fiber connections can be made.

**NOTE:** Include filters, shutoff and drain valves, and pneumatic controls in the fluid circulation system as needed. All station components must be suitable for system volumes, pressures, and flow rates. Proper station layout and construction is the responsibility of the user.

Refer to [Appendix A: System Design, page 150](#) for additional guidance in designing an Intelligent Paint Kitchen system.

## Overview of Installation Steps

Each Intelligent Paint Kitchen installation is unique and varies, depending on the number of stations, the configuration, and the specific components being used.

The following general steps apply to most Intelligent Paint Kitchens:

1. Mount the components (Supervisor Box, Variable Frequency Drive, Touchscreen Box, and DC Power Supply with Barrier) in the non-hazardous location.
2. Make all required ground connections.
3. Connect the components together in the non-hazardous location.
4. Use a fiber optic cable to connect the components in the non-hazardous location to each station in the hazardous location.

## Before Installation

Before installation, verify the following:

- All system and component documentation is available during installation.
- Component manuals have been reviewed for specific data on component requirements.
- All accessories are adequately sized and pressure-rated to meet system requirements.
- Design the non-hazardous location component layout. Decide where the Touchscreen Box (if used), each Supervisor Box, each Expansion Box, each Variable Frequency Drive/Inverter, and each DC Power Supply will be located.
- Components installed in the hazardous location must be installed using the instructions in the manual for each component.

## Check Resistance

				
To reduce the risk of fire, explosion, or electric shock, the resistance between the Intelligent Paint Kitchen components and true earth ground must be less than 1 ohm.				

Check the resistance between each Intelligent Paint Kitchen component and true earth ground. If the resistance is 1 ohm or greater, a different ground may be required. Do not operate the system until the problem has been corrected.

## Connections to the E-Flo DC Pump

For complete warnings and operation instructions for the E-Flo DC pump, see the following manuals:

Manual No.	Description
333389	E-Flo DC 2-Ball Piston Pumps
3A2096	E-Flo DC 4-Ball Piston Pumps
3A3384	E-Flo DC 4-Ball Pumps, Sealed or with Open Wet Cup
3A3453	E-Flo® DC 2000, 3000, and 4000 Circulation Pumps
3A2526	E-Flo DC Motor, Single Phase
3A4409	E-Flo DC Motor, Three Phase

### Connect the E-Flo DC Pump to the Pump Control Module

Each station has one Pump Control Module (PD) attached to the E-Flo DC pump (C) with an intrinsically safe CAN cable. Use cable 16P911 (3 feet / 1 meter) or cable 16P912 (25 feet / 8 meters), as needed.

1. Connect one end of the cable to the power terminal (PT) on the motor.
2. Connect the other end of the cable to Port 3 on the bottom of the Pump Control Module.

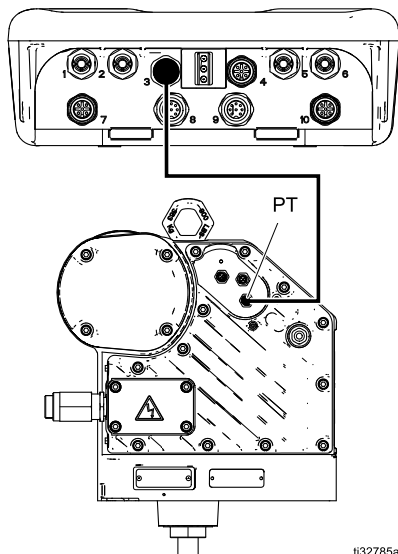

Figure 19 Pump Control Module Connections to E-Flo DC Pump, Single Phase

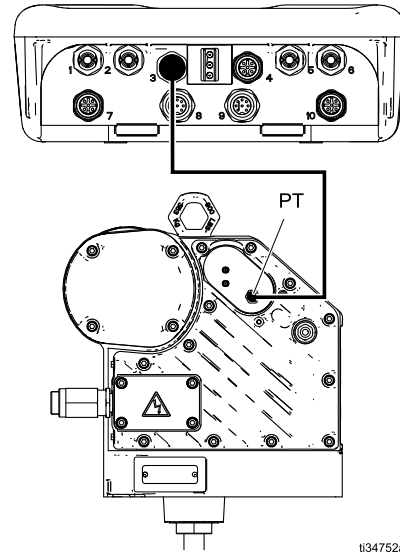

Figure 20 Pump Control Module Connections to E-Flo DC Pump, Three Phase

### Connections to the Tank Control Module

For complete warnings and operation instructions for the Tank Control Module (TD), see the Tank Control Module Kit manual 3A5991.

#### Connect a DC Power Supply to the Tank Control Module

A DC Power Supply with Barrier (S), installed in the non-hazardous location, provides VDC power to Tank Control Modules (TD).





Use intrinsically safe cable as required by the distance between the two components. The following IS power cables are available:

- 16K509 (52 ft / 16 m)
- 16K615 (105 ft / 32 m)

For wiring details, see the IS Power Supply Modules manual 332196.

## Radar Level Sensors

### Grounding the Radar Level Sensors

				
<p>This equipment must be grounded to reduce the risk of static sparking and electric shock. Electric or static sparking can cause fumes to ignite or explode. Improper grounding can cause electric shock. Grounding provides an escape wire for the electric current.</p>				

Follow these steps to ground the Radar Level Sensors (M, T):

1. Loosen the ground screw and attach a ground wire. A ground wire and clamp, part number 223547, is available from Graco.
2. Tighten the ground screw securely.
3. Connect the other end of the ground wire to a true earth ground.

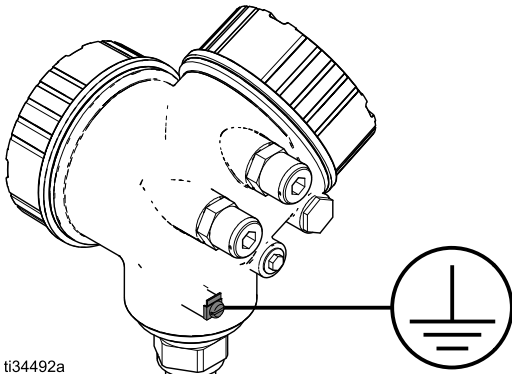

ti34492a

Grounding a Radar Level Sensor

Figure 21

For complete warnings and operation instructions, see the manufacturer's manual that is shipped with the product.

### Connect a Radar Level Sensor to a Pump Control Module or Tank Control Module

Use this procedure to connect a Radar Level Sensor (M, T) to a Pump Control Module (PD) or Tank Control Module (TD).

- For information on setting up the Pump Control Module and the Tank Control Module, see [Examples of Component Connections, page 23](#).
- For complete warnings and operation information, see the manufacturer's manual shipped with the Radar Level Sensor.

**NOTE:** The following illustrations show connections to a Graco-approved Radar Level Sensor. If you are not using a Graco-approved Radar Level Sensor, contact your distributor.

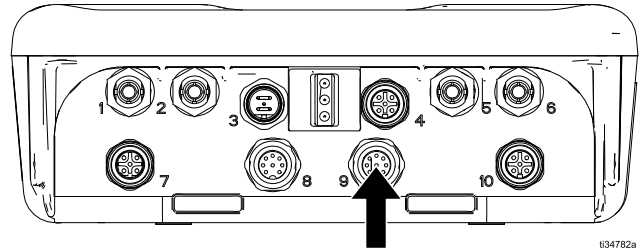

ti34782a

Figure 22 Primary Tank: Connect Port 9 to the Pump Control Module

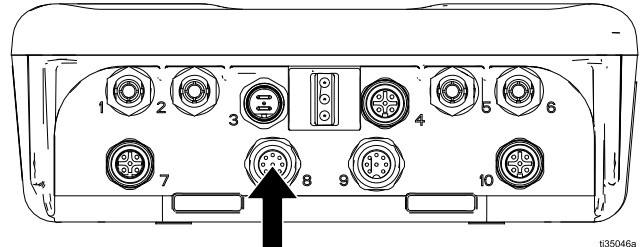

ti35046a

Figure 23 Primary Tank: Connect Port 8 to the Tank Control Module

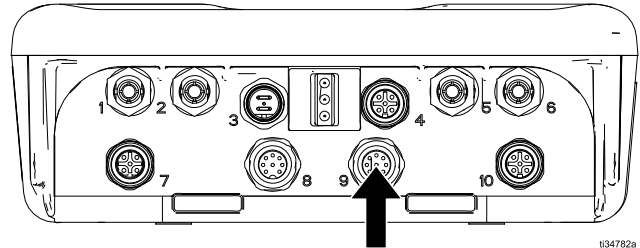

ti34782a





Figure 24 Secondary Tank: Connect Port 9 to the Tank Control Module

## Variable Frequency Drive/Inverter Connections

This section contains steps to set up connections to the Graco Variable Frequency Drive/Inverter (B).

Graco Variable Frequency Drives/Inverters include parts 17N041, 17N042, and 17N043. For complete warnings and operation instructions for Graco Variable Frequency Drives/Inverters and agitator wiring, see the Variable Frequency Drives manual 3A4793, the Electric Direct Drive Agitator manual 3A4553, the Electric Driven Back-Gear Drum Agitators manual 3A4548, and the manufacturer's manual.

### Digital Input Configuration

				
<p>Improper wiring may cause electric shock or other serious injury if work is not performed properly. All electrical wiring must be done by a qualified electrician and comply with all local codes and regulations.</p>				

For Lenze SMVector, install the wiring at the Variable Frequency Drive/Inverter as follows:

1. Connect the Variable Frequency Drive/Inverter jumper wires.

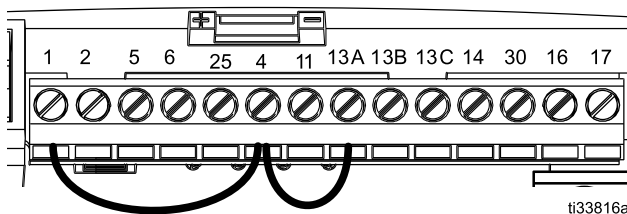

Figure 25 Variable Frequency Drive/Inverter Jumper Wires

Terminal	Description	Note
1	Digital Input: Start/Stop	Input resistance = 4.3 kΩ
2	Analog Common	
5	Analog Input: 0...10 VDC	Input resistance: > 50 kΩ

Terminal	Description	Note
6	Internal DC supply for speed pot	+10 VDC, max 10 mA
25	Analog Input: 4...20 mA	Input resistance = 250 kΩ
4	Digital Reference/Common	+15 VDC / 0 VDC, depending on assertion level
11	Internal DC supply for external devices	+12 VDC, max 50 mA
13A	Digital Input: Configurable with P121	Input resistance = 4.3 kΩ
13B	Digital Input: Configurable with P122	
13C	Digital Input: Configurable with P123	
14	Digital Output: Configurable with P142, 144	DC 24 V / 50 mA; NPN
30	Analog Output: Configurable with P150...P155	0...10 VDC, max. 20 mA
16	Relay Output: Configurable with P140, P144	AC 240V / 3 A
17		DC 24V / 2 A...240V / 0.22 A, noninductive

2. Perform the Variable Frequency Drive/Inverter configuration as specified in [Set Up a Lenze Variable Frequency Drive/Inverter for Modbus Communication](#), page 56.

See [Appendix D: Communication Configuration](#), page 158, for configurations specific to either an Allen Bradley PowerFlex drive or a Mitsubishi drive/inverter.

## RS-485 Module Installation

Follow these steps to install the RS-485 module, which is shipped with Graco Variable Frequency Drives/Inverters (B) 17N041, 17N042, and 17N043.

1. Verify that the AC supply has been disconnected before opening the terminal cover.
2. Remove the terminal cover.
3. Insert the RS-485 module in the terminal cover. Securely click the module into position.

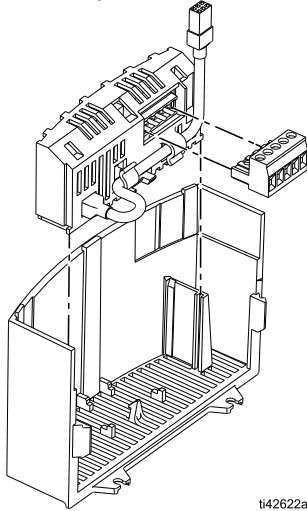

ti42622a

4. Connect the Variable Frequency Drive/Inverter using the RS-485 data communication wiring. For more information, see [Wire the Variable Frequency Drive/Inverter to the Supervisor Module, page 37](#).
5. Plug the connector into the RS-485 module.
6. Align the terminal cover for re-fitting.
7. Connect the RS-485 module cord to the drive.
8. Close the cover and secure it.

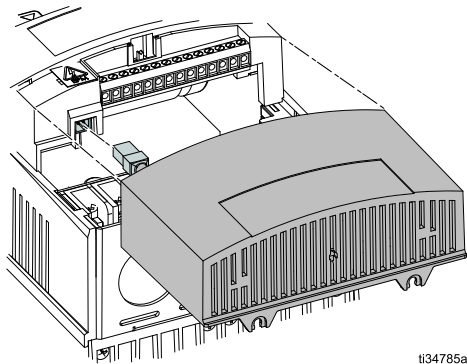

ti34785a

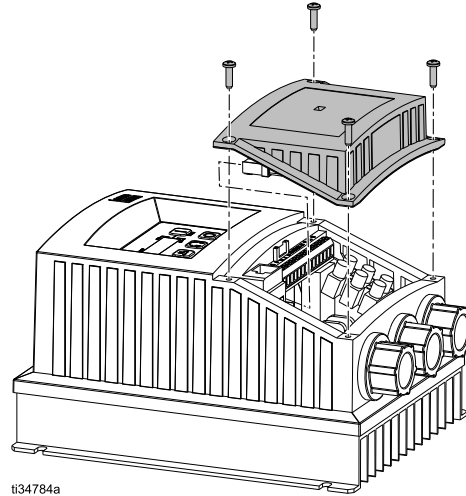

ti34784a

## Label All Mounted Components

As a best practice to avoid confusion, clearly label each component mounted in the non-hazardous and hazardous locations.

Make sure that you can easily see which stations and their components in the hazardous location are controlled by each Supervisor Box and Variable Frequency Drive/Inverter in the non-hazardous location.

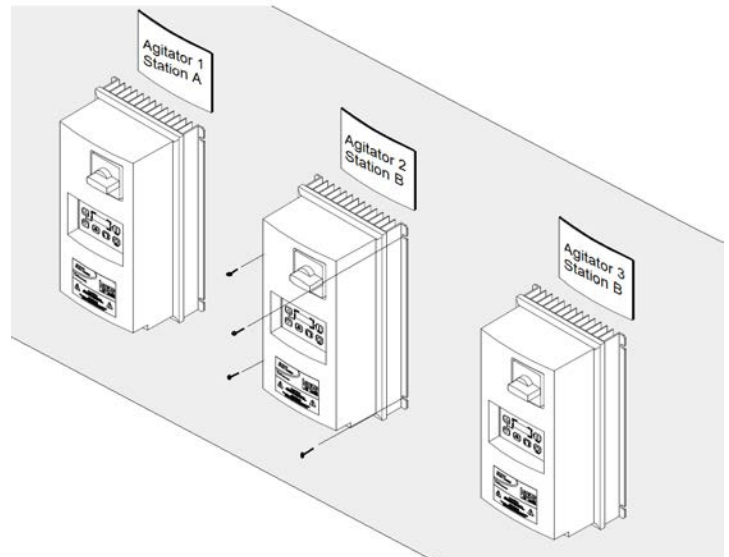





Figure 26 Example – Mounting and Labeling Three Variable Frequency Drive/Inverter Boxes

## Supervisor Box

### Connect Power to the Supervisor Box

				
<p>Improper wiring may cause electric shock or other serious injury if work is not performed properly.</p> <ul style="list-style-type: none"> <li>This equipment must be grounded. Connect only to a grounded power source.</li> <li>All electrical wiring must be done by a qualified electrician and comply with all local codes and regulations.</li> </ul>				

### NOTICE

If power and grounding connections are not done properly, the equipment will be damaged and the warranty voided.

The Supervisor Box (A) is rated for 100–240 VAC, 50–60 Hz, with a maximum of 1 amp current draw.

*Not included with the system:* Power disconnection, branch circuit protection, and power supply cord.

NOTE: A means of disconnect must be provided during installation. Branch circuit protection of 15 amp maximum must be provided during installation. Power wires must be made of copper and have a minimum temperature rating of 60°C (140°F). The wire gauge size must be 12–14 AWG.

1. Turn off power rocker switch (2) to ensure the Supervisor Box (A) is off.
2. Open the electrical enclosure door.
3. Route the power cable through the strain relief in the bottom of the box.

NOTE: Strain relief or conduit connection to the opening must be provided, according to electrical requirements.

4. Tighten the strain relief.
5. Connect the supply ground wire to the protective earth ground terminal (7b) provided in the enclosure.
6. Connect the incoming power wires to the terminal block (56) inside the Supervisor Box. Gently pull on all connections to verify that they are properly secured.

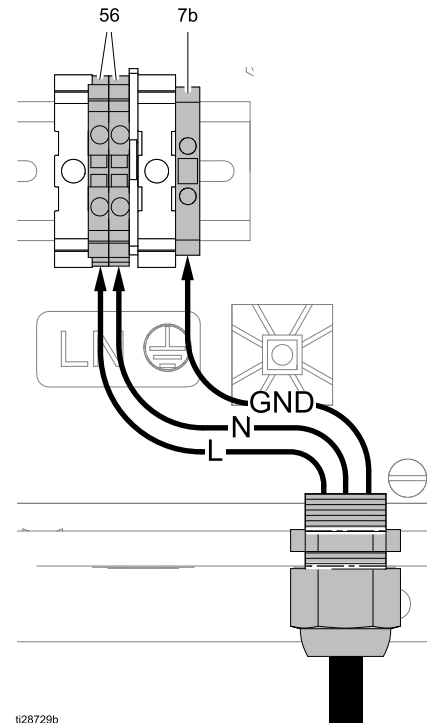

Figure 27 Connect Power to the Supervisor Box

7. Torque terminals to 5.3 - 7.0 in-lb (0.6 - 0.8 N•m).
8. Verify that all items are connected properly, then close the electrical enclosure door.



## Install the Serial to Fiber Optic Converters

Every Intelligent Paint Kitchen must have one Supervisor Box (A) installed in the non-hazardous location. Each Supervisor Box is shipped with one serial to fiber optic converter (38) already installed inside the box.

During installation, serial to fiber optic converters may need to be installed inside the Supervisor Box. To install components inside the boxes, see [Mounting and Dismounting to the DIN Rail, page 32](#).

If the number of stations in the paint kitchen exceeds the number that can be handled, the system can be expanded. See [Appendix A: System Design, page 150](#).

### Mounting and Dismounting to the DIN Rail

				
<p>Improper wiring may cause electric shock or other serious injury if work is not performed properly. Turn off and disconnect power at the main switch before servicing or installing equipment.</p>				

Disconnect the power before servicing the equipment.

Components located inside the Supervisor Boxes and Expansion Boxes are to be mounted on a 35 mm standard DIN rail.

The DIN rail clip on each component is spring-loaded. No tool is needed to install or remove the components.

**NOTE:** Mount each component onto the DIN rail **before** making power or communication connections to the component.

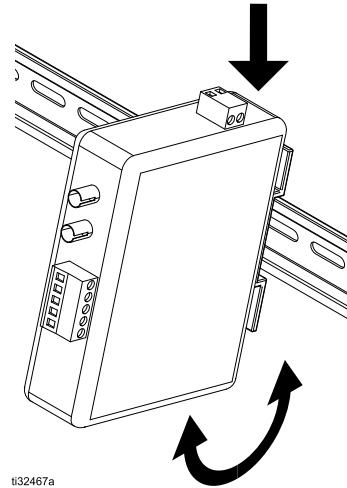

Figure 28 Mounting Fiber Optic Converter to DIN Rail

The spring must be latched behind the edge of the DIN rail to connect properly.

To remove a component from the DIN rail, pull down to compress the spring, pull the bottom out to release it from the rail, and lift it up off the top of the DIN rail.

Install a clamp end block (6) to hold the components tightly together on the DIN rail.



## Set DIP Switches on the Fiber Optic Converters

Each Supervisor Box (A) contains one to ten fiber optic converters (38). Each station requires one converter, and each Supervisor Box is shipped with one fiber optic converter. The DIP switches on the bottom of each fiber optic converter must be configured according to the required baud rate.

**NOTE:** It is easiest to set the DIP switches before mounting the fiber optic converters inside the Supervisor Box or Expansion Box.

- These settings are for RS-485 two-wire cable connections.
- Set the selector switch to RS-422/485.
- Use the settings in the DIP Switch Settings (57600 baud rate) figure for systems using a 57600 baud rate. Use the settings in the DIP Switch Settings (38400 baud rate) figure for systems using a 38400 baud rate.
- In the following figures, white indicates the DIP switch position.

**NOTE:** Unless a 38400 baud rate is required, it is recommended to run the system with a 57600 baud rate to increase communication speeds.

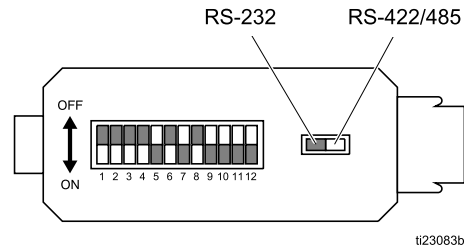

Figure 29 DIP Switch Settings (57600 baud rate)

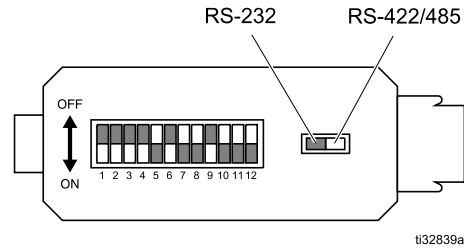



Figure 30 DIP Switch Settings (38400 baud rate)



### Connect DC Power to the Fiber Optic Converters

				
All electrical wiring must be done by a qualified electrician and comply with all local codes and regulations.				

<b>NOTICE</b>
If power and grounding connections are not done properly, the equipment will be damaged and the warranty voided.

**Supervisor Box:** Each Supervisor Box (A) is shipped with one fiber optic converter installed and connected to the 24 VDC power supply. If multiple converters are installed in the box, connect them to the Supervisor Box power supply as shown in the following figure, [Connect 24 VDC Power Supply to Fiber Optic Converters](#). When installing wires, torque terminals to 4.4 – 5.3 in-lb (0.5 – 0.6 N•m).

**Expansion Boxes:** If used, Expansion Boxes are shipped with one fiber optic converters installed. After installing more fiber optic converters if needed, connect each one to the power supply.

Wire	Color
	Red
	Black

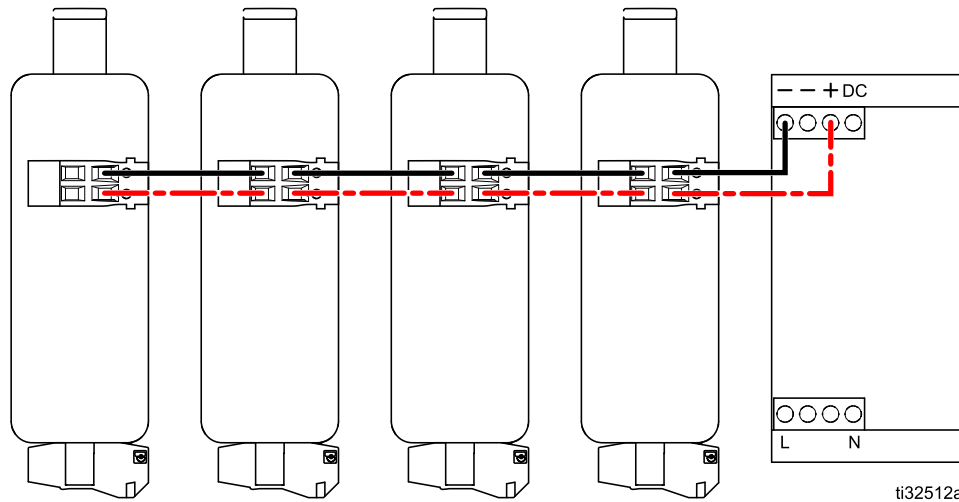

Figure 31 Connect 24 VDC Power Supply to Fiber Optic Converters

ti32512a

## Label the Fiber Optic Converters

For Intelligent Paint Kitchen maintenance and troubleshooting purposes, it is important to know which station is connected to each fiber optic converter.

If your Intelligent Paint Kitchen system controls multiple stations, it is recommended to mark each fiber optic converter with a label (for example, 3), clearly indicating the station connected to that fiber optic converter.

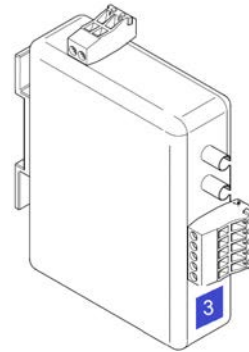

Figure 32 Fiber Optic Converter with Identifying Label

## Modbus (RS-485) Wiring

If a Supervisor Box (A) contains more than one fiber optic converter, the converters must be wired in series and the first converter connected to the Supervisor Module (36).

Use solid blue and white/blue RS-485 data communication rated cables.

On the final fiber optic converter in the series, install a 120 ohm resistor to terminate the series.

**NOTE:** Remember to set the DIP switches located on the bottom of each fiber optic converter. See [Set DIP Switches on the Fiber Optic Converters, page 33](#). When installing wires, torque terminals to 4.4 – 5.3 in-lb (0.5 – 0.6 N•m).

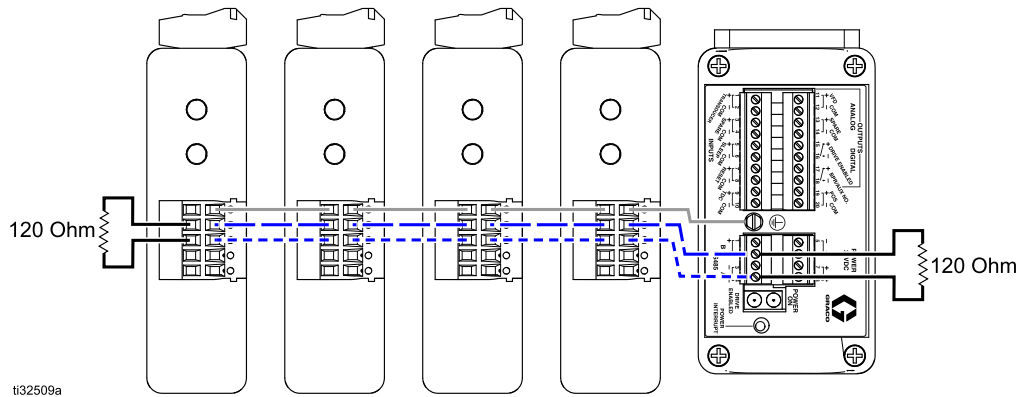



Figure 33 Four Fiber Optic Converters Wired in Series to the Supervisor Module

Installation and Wiring

Wire	Color
	White/Blue
	Blue

If an Expansion Box is used with the Supervisor Box (A), continue the series so that all fiber optic converters are connected to the Supervisor Module (36) in one long series.

NOTE: The Modbus (RS-485) shield wire is intended to be connected to the EMC ground terminal (7a) in the Supervisor Box (A) only.

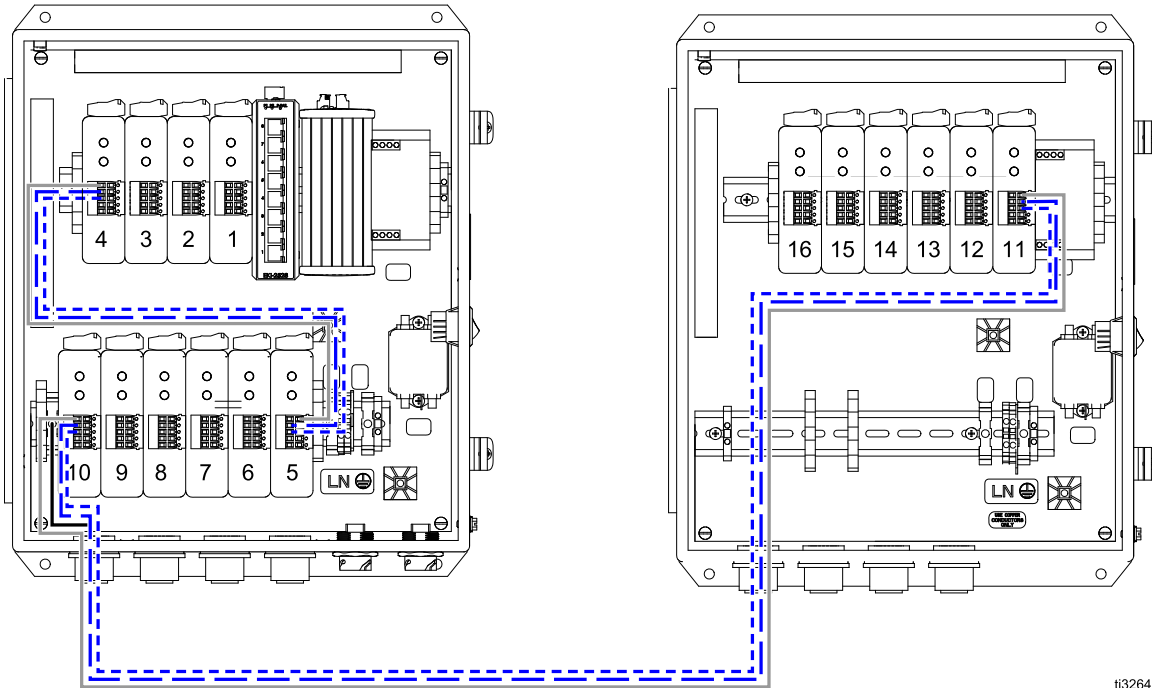

ti32643a

Figure 34 Fiber Optic Converters in an Supervisor Box (shown at left) Wired in Series to the Expansion Box (shown at right)

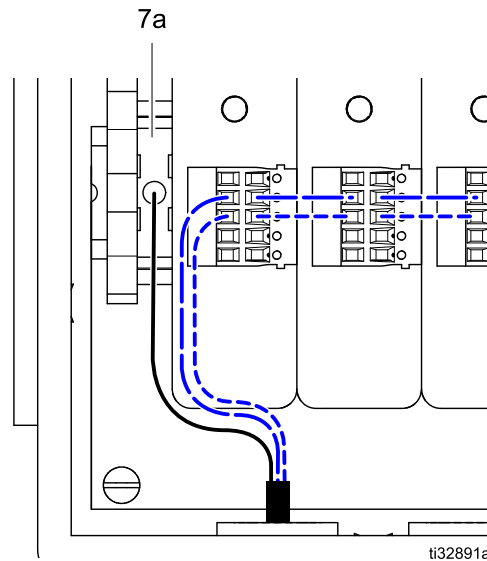

ti32891a

Figure 35 Detail – Ground the Wired Series at the Supervisor Box EMC Ground Terminal

## Wire the Variable Frequency Drive/Inverter to the Supervisor Module

Each electric agitator in the Intelligent Paint Kitchen system can be remotely controlled by a Variable Frequency Drive/ Inverter (B) installed in the non-hazardous location.

Every Variable Frequency Drive/Inverter must be connected to the Supervisor Module (36) inside a Supervisor Box (A), and to an agitator in a station.

If your system uses a Variable Frequency Drive/Inverter to control the agitator, connect a blue and white/blue twisted wire from the Variable Frequency Drive/Inverter to the last fiber optic converter in the wired series.

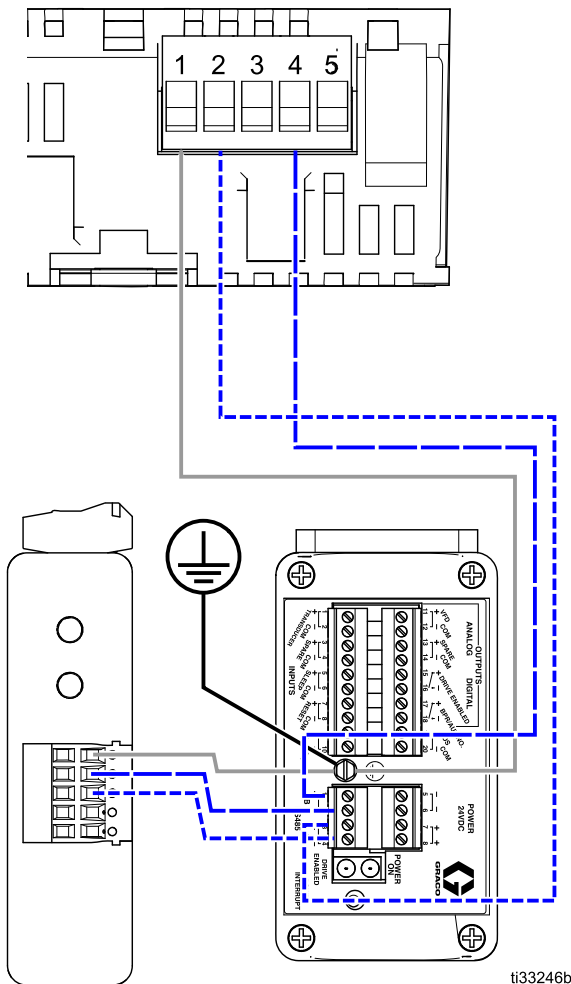

Figure 36 Connect a Variable Frequency Drive/Inverter (Lenze model shown, at top) to the Supervisor Module (shown at bottom)

If a station is connected to multiple Variable Frequency Drives/Inverters, wire the Variable Frequency Drives/Inverters together in series, using terminals 2 and 4 on the Modbus module installed inside the Variable Frequency Drive/Inverter as shown. On the final Variable Frequency Drive/Inverter in the series, install a 120 ohm resistor to terminate the series.

Wire	Color
-----	White/Blue
-----	Blue

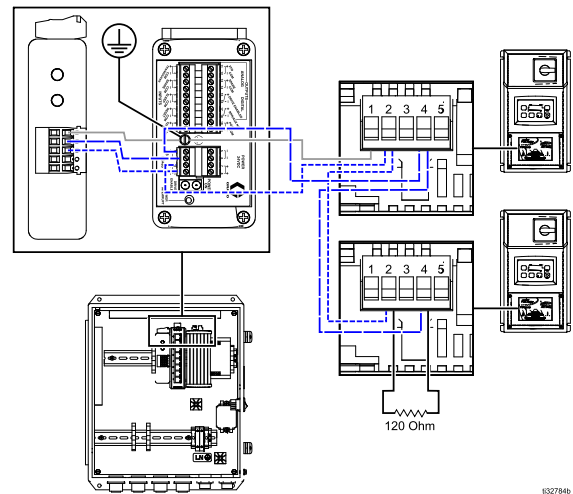





Figure 37 Wire the Variable Frequency Drives/Inverters Together in Series

## Expansion Box

### Connect Power to the Expansion Box

				
<p>Improper wiring may cause electric shock or other serious injury if work is not performed properly.</p> <ul style="list-style-type: none"> <li>This equipment must be grounded. Connect only to a grounded power source.</li> <li>All electrical wiring must be done by a qualified electrician and comply with all local codes and regulations.</li> </ul>				

### NOTICE

If power and grounding connections are not done properly, the equipment will be damaged and the warranty voided.

If your Intelligent Paint Kitchen system includes one or more Expansion Boxes, each must be wired to a 100–240 VAC, 50/60 Hz power source and has a maximum 1 amp current draw.

*Not included with the system:* Power disconnection, branch circuit protection, and power supply cord.

NOTE: A means of disconnect must be provided during installation. Branch circuit protection of 15 amp maximum must be provided during installation. Power lines must be made of copper and have a minimum temperature rating of 60°C (140°F). The wire gauge size must be 12–14 AWG.

1. Turn off power rocker switch (2) to ensure the Expansion Box is off.
2. Open the electrical enclosure door.
3. Route the power cable through the strain relief in the bottom of the box.

NOTE: Strain relief or conduit connection to the opening must be provided, according to electrical requirements.

4. Tighten the strain relief.
5. Connect the supply ground wire to the protective earth ground terminal (7b) provided in the enclosure.
6. Connect the incoming power wires to the terminal block (56) inside the Expansion Box. Gently pull on all connections to verify that they are properly secured.

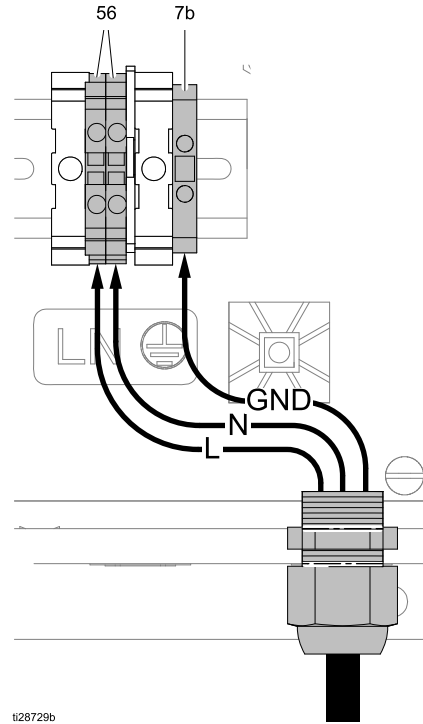

Figure 38 Connect Power to an Expansion Box



7. Torque terminals to 5.3 - 7.0 in-lb (0.6 - 0.8 N•m).
8. Verify that all items are connected properly, then close the electrical enclosure door.

## Connect Pump and Tank Control Modules to the Supervisor Box

Use fiber optic cables to connect each fiber optic converter to a Pump Control Module (PD). If the paint kitchen contains both a Pump Control Module and a Tank Control Module (TD), connect them together using a fiber optic cable. See the [Cable Lengths](#) table.

1. Disconnect the power.
2. Connect the Tank Control Module (if used) in the hazardous location to the Pump Control Module, also in the hazardous location:
  - a. Plug the two connectors at one end of cable (FA) into Port 1 and Port 2 on the Tank Control Module.
  - b. Plug the two connectors at the other end of cable (FA) into Port 5 and Port 6 on the Pump Control Module.

3. Connect the Pump Control Module in the hazardous location to a fiber optic converter in the Supervisor Box in the non-hazardous location:
  - a. Plug the two connectors at one end of cable (FB) into Port 1 and Port 2 on the Pump Control Module.
  - b. Plug the two connectors into the RX and TX Ports on a fiber optic converter inside the Supervisor Box.

Wire	Color
	Orange with red ends
	Orange with black ends

**Hazardous Location**

**Non-hazardous Location**

Figure 39

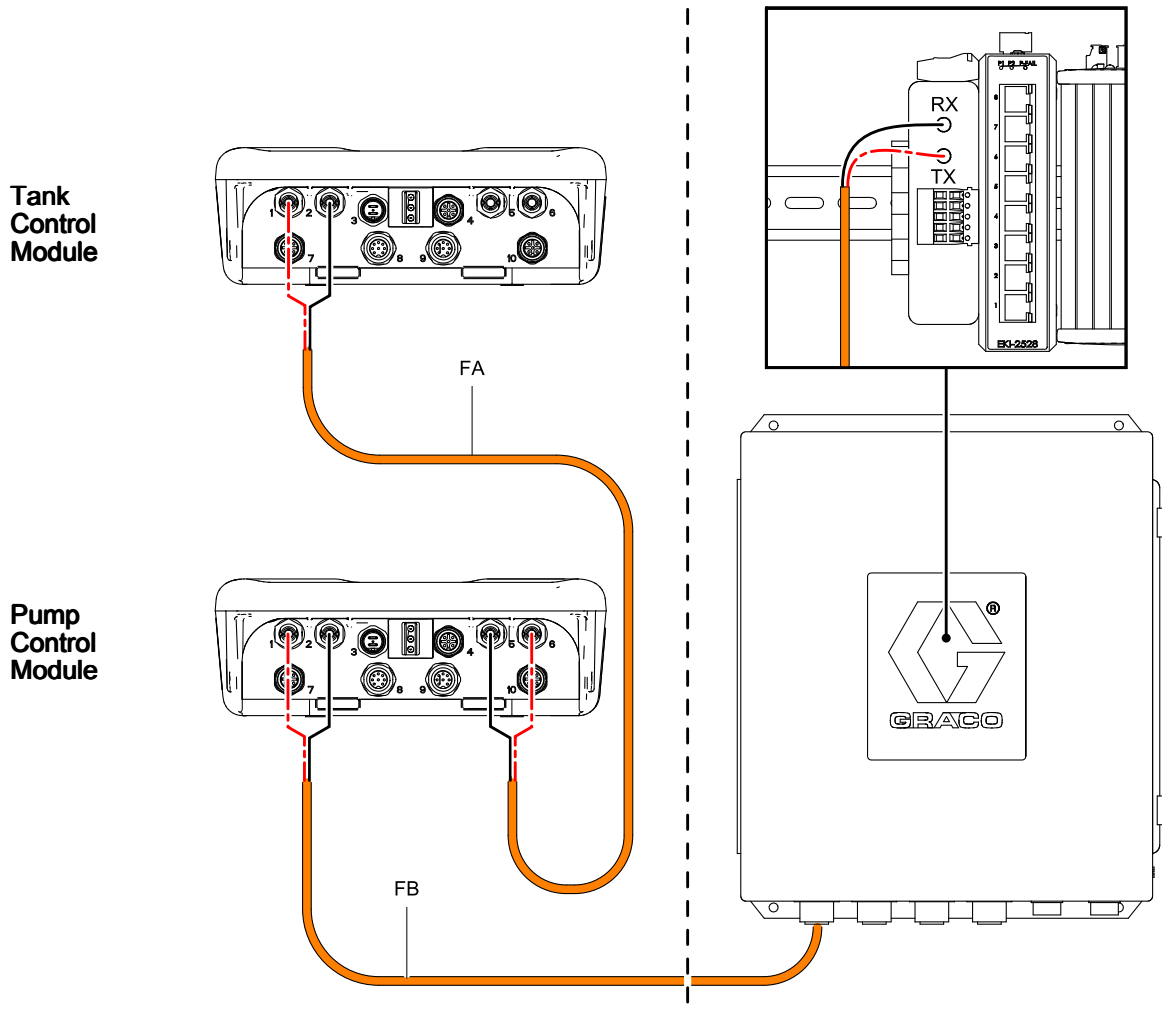

t132645a

**Cable Lengths**

Fiber Optic Cable No.	Cable Length
17T898	10 feet (3 m)
16M172	50 feet (16 m)
16M173	100 feet (30 m)
17B160	330 feet (100 m)

Use cables 17T898, 16M172, 16M173, or 17B160, depending on the length needed. Graco recommends using the shortest cable needed to make the fiber optic connections.

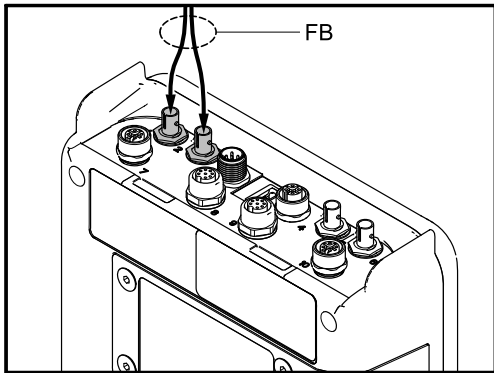
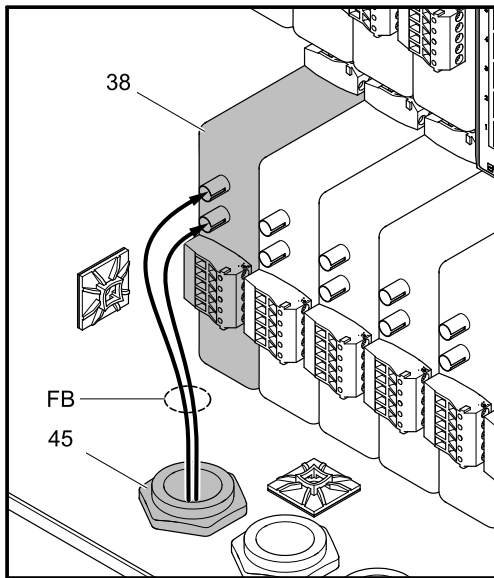





Figure 40 Connect Fiber Optic Converter to Pump or Tank Control Module



## Touchscreen Box

### Connect Power to the Touchscreen Box

				
<p>Improper wiring may cause electric shock or other serious injury if work is not performed properly.</p> <ul style="list-style-type: none"> <li>This equipment must be grounded. Connect only to a grounded power source.</li> <li>All electrical wiring must be done by a qualified electrician and comply with all local codes and regulations.</li> </ul>				

### NOTICE

If power and grounding connections are not done properly, the equipment will be damaged and the warranty voided.

The Touchscreen Box (J) is rated for 100–240 VAC, 50–60 Hz, with a maximum of 1 amp current draw.

*Not included with the system:* Power disconnection, branch circuit protection, and power supply cord.

NOTE: A means of disconnect must be provided during installation. Branch circuit protection of 15 amp maximum must be provided during installation. Power wires must be made of copper and have a minimum temperature rating of 60°C (140°F). The wire gauge size must be 12–14 AWG.

1. Turn off power rocker switch (2) to ensure the Touchscreen Box is off.
2. Open the electrical enclosure door.
3. Route the power cable through the strain relief in the bottom of the box.

NOTE: Strain relief or conduit connection to the opening must be provided, according to electrical requirements.

4. Tighten the strain relief.
5. Connect the supply ground wire to the protective earth ground terminal (7b) provided in the enclosure.
6. Connect the incoming power wires to the terminal block (56) inside the Touchscreen Box. Gently pull on all connections to verify that they are properly secured.

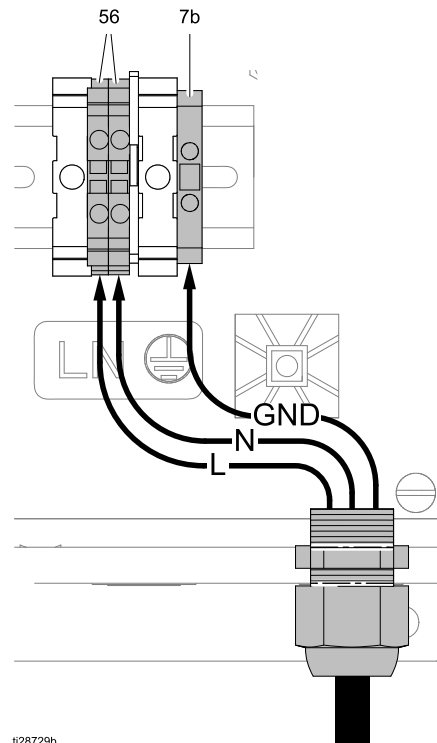

Figure 41 Connect Power to Touchscreen Box

7. Torque terminals to 5.3 – 7.0 in-lb (0.6 – 0.8 N•m).
8. Verify that all items are connected properly, then close the electrical enclosure door.

### Connect the Supervisor Box to the Touchscreen Box

The Touchscreen Box (J) requires a communication connection to the first Supervisor Box (A).

Connect a CAT5 Ethernet cable from Ethernet port 2 on the Touchscreen Box to either Ethernet port on the Supervisor Box.

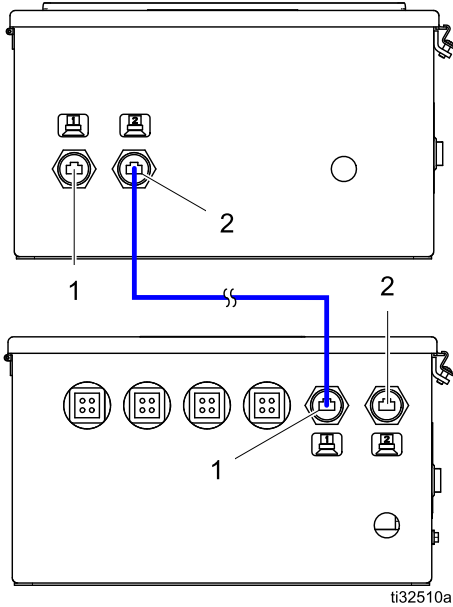

Figure 42 Connect the Supervisor Box (bottom) to the Touchscreen Box (top)

### I/O Module 17T198

The I/O module is part of the optional light tower kit 122193.

Indicator	Terminal
Common	1 and 4
Red light	2
Yellow light	3
Green light	5
Siren	6

## Connect the Light Tower to the Touchscreen Box

If the optional light tower accessory is used, mount and wire it to the Touchscreen Box (J).

1. Disconnect the power supply.
2. Remove the plug (12) on top of the Touchscreen Box. Feed the wires through the hole and secure the light tower (LT) with jam nuts (JN) on the inside and outside of the box.

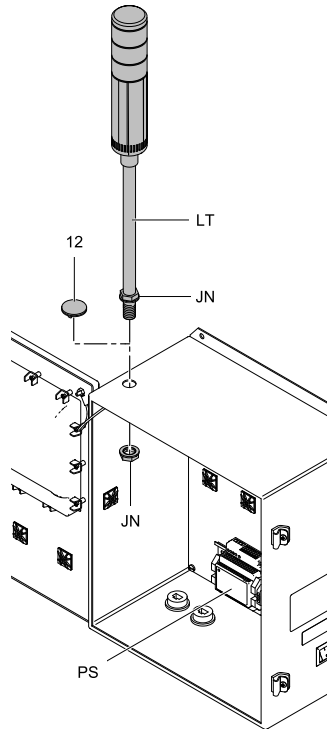

ti32468a

Figure 43 Connect the Light Tower

3. Mount the light tower I/O module (I/O) to the rear of the Touchscreen Box:
  - a. Remove the rubber module plug (PL).

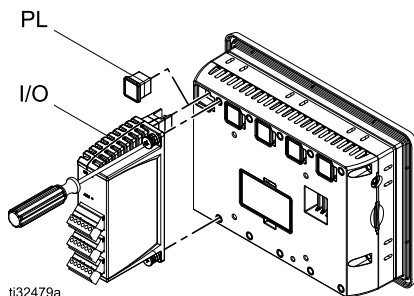

ti32479a

Figure 44 Attach the I/O Module

- b. Use two screws to secure the I/O module to the Touchscreen Module. Tighten to 6 in-lb (0.68 N·m).

4. Install a black jumper wire between terminals 1 and 4 on the I/O module.
5. Connect the light tower wires to the I/O module as follows:
  - Orange wire: Connect to terminal 3.
  - Green wire: Connect to terminal 5.
  - Red wire: Connect to terminal 2.
6. To enable the optional audible alarm, connect the violet wire to terminal 6. When enabled, the light tower sounds for all system alarms.
7. Run the common wire (black) from terminal 1 on the I/O module to the Power (-) port on the Touchscreen Box.
8. Connect the yellow wire from the light tower to the (+) terminal on the power supply (PS).

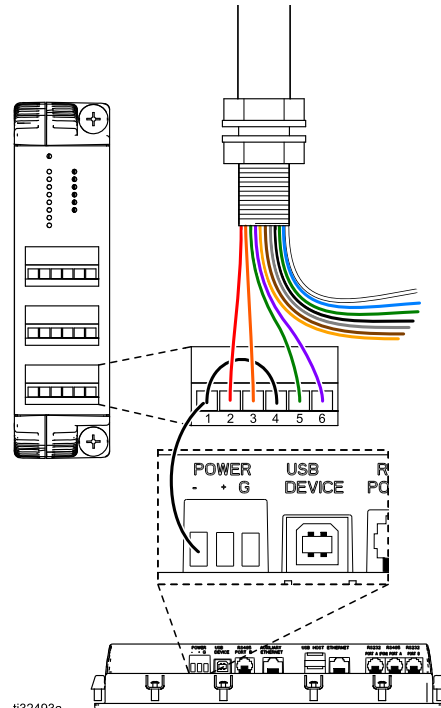

ti32493a

Figure 45 Connect the I/O Module

## Power Off

Turn the AC Power Switches (2) off (1 = ON, 0 = OFF) for each of the following Intelligent Paint Kitchen components:

- Touchscreen Box
- Supervisor Box or Boxes
- Expansion Box or Boxes

NOTE: If you turn the power off to the Touchscreen Box only, the system continues to operate.

## Power On

Turn the AC Power Switches (2) on (1 = ON, 0 = OFF) for each of the following Intelligent Paint Kitchen components:

- Touchscreen Box
- Supervisor Box or Boxes
- Expansion Box or Boxes

The Graco logo displays while the system initializes, followed by the Stations screen.

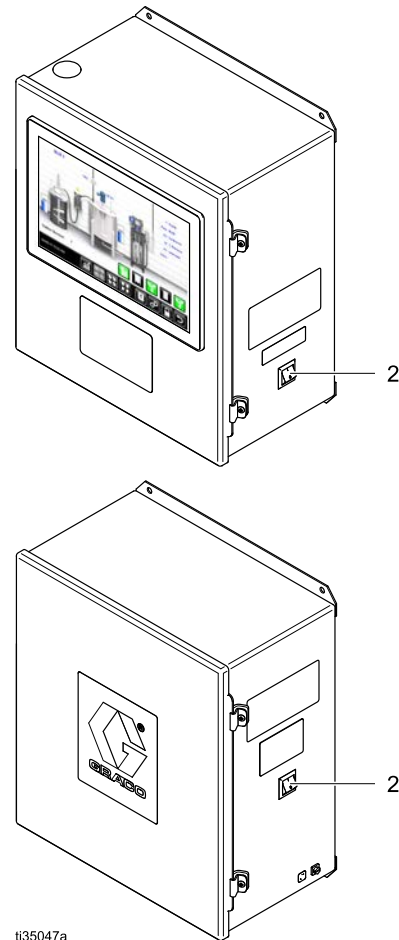

t135047a

Figure 46 Power Switches ("On" position shown)

# Software Setup

## Software Overview

The Intelligent Paint Kitchen uses software that allows the components to communicate with each other. The software is also used to set up the system and specify operating conditions.

The following Intelligent Paint Kitchen components contain their own embedded software:

- The Touchscreen software manages the interface between the user and the Intelligent Paint Kitchen. The software allows users to view current information on the Touchscreen Module (14), and to enter information and commands into the Touchscreen Module.
- The Supervisor software runs the Intelligent Paint Kitchen. Use it to configure the station components, to set up communication and operating parameters between the Supervisor Box (A) and the station components, to set up event handling, and to operate each station in the system.
- The Pump Control Module (PD) software provides the interface between the Intelligent Paint Kitchen software in the non-hazardous location and the following components in the hazardous location of the station:
  - Pump Run/Stop Switch (U)
  - Primary Tank Agitator (L)
  - Primary Tank Radar Level Sensor (M)
  - Back Pressure Regulator Controller (F)
  - Pressure Transducers (K)
  - Fill Pump Transfer Solenoid (P)
- The Tank Control Module (TD) software provides the interface between the Intelligent Paint Kitchen software in the non-hazardous location and the following components in the hazardous location of the station:

- Level Sensor for the Primary/Secondary Tank Agitators (M, T)
- Pneumatic Fill Pump Transfer Solenoid (P)

**NOTE:** When a station contains both a Pump Control Module and a Tank Control Module, some component connections move from the Pump Control Module to the Tank Control Module.

**NOTE:** Although the Pump Control Module and the Tank Control Module look identical, they each have their own specific software installed. They are not interchangeable components.

## Enter the Node IDs

A node ID is automatically generated for each paint kitchen component that communicates directly with the Intelligent Paint Kitchen software.

When the stations have been configured ([Configure Each Station, page 66](#)), each generated node ID must be entered into the corresponding paint kitchen component. Every Variable Frequency Drive/Inverter, every Pump Control Module, and every Tank Control Module must have its unique node ID programmed into it, in order for those devices to communicate with the rest of the system.

Each node ID generated by the Intelligent Paint Kitchen software must match the node ID for a specific component located in the station.

Matching component node IDs with the node IDs entered into the software allows the Intelligent Paint Kitchen software to communicate with and control the system.

See [Appendix E: Node ID Assignments, page 162](#) for a complete list of node ID assignments.

## Set Up Pump Controls

For complete warnings and operation instructions, see the E-Flo DC Control Module Kit manual 3A2527.

### Pump Control Module Nodes

Each station may have one pump that creates and maintains fluid pressure in that station's circulation system. A Pump Control Module (PD) provides the communication between each pump and the Intelligent Paint Kitchen software.

Use each Pump Control Module's keypad and display to enter the node ID that was generated when the station was configured.

Use the instructions in the E-Flo DC Control Module Kit manual 3A2527 to access the Setup screens and enter the correct node ID.

You must also use the Pump Control Module software to set the control module to Network mode and to set the baud rate.

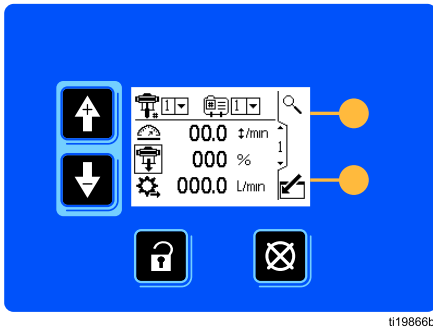

**NOTE:** Entering the correct node ID into each control module allows the Touchscreen Box (J) and Supervisor Box (A) to communicate with each pump. It does not set the speed or pressure of each pump. Later in this setup process, you can create pump profiles that determine pump operation under different conditions. See [Create Pump Profiles, page 87](#).

## Set Up Tank Controls

For complete warnings and operation instructions, see the Tank Control Module Kit manual 3A5991.

### Tank Control Module Nodes

Every station that has a Secondary Tank (H) with tank monitoring and an agitator must also have a Tank Control Module (TD). This control module looks identical to the Pump Control Module (PD), but it contains different software. It provides the communication between each Secondary Tank and the Intelligent Paint Kitchen software.

Use each control module's keypad and display to enter the node ID that was generated when the station was configured.

Use the instructions in the Tank Control Module Kit manual 3A5991 to access the Setup screens and enter the correct node ID.

When all node IDs have been entered into the Variable Frequency Drives/Inverters (B) and the Tank Control Modules, go to [Turn on Node Communication, page 69](#) to continue setting up the system.







## Control Module Software

Pump Control Modules and Tank Control Modules located in each hazardous location can be set up locally, using the keypad and display to access and change the software settings.

Use the control module software to:

- Place the control module in Remote Control mode. See [Set Up a Pump Control Module for Modbus Communication, page 48](#) and [Set Up a Tank Control Module for Modbus Communication, page 49](#).
- Set the baud rate for control module communication. The baud rate must match the baud rate of the Supervisor Module. See [Set Up a Pump Control Module for Modbus Communication, page 48](#) and [Set Up a Tank Control Module for Modbus Communication, page 49](#).
- Set up the Reed Switch, Agitator Halt Drum Cover Switch, Primary Tank High and Low Alarm Output, and Auxiliary Solenoid. See [Set Up Pump Control Module Configurable I/O, page 50](#) and [Set Up Tank Control Module Configurable I/O, page 52](#).
- Enter the unique node ID generated by the Intelligent Paint Kitchen software for the control module. See [Configure Each Station, page 66](#).

See the E-Flo DC Control Module Kit manual 3A2527 or the Tank Control Module Kit manual 3A5991 for complete warnings and operating instructions, including how to use the keypad to access and change the software settings.

Key	Name	Function
	Toggle	Toggle between Run screens and Setup screens.
	Error Reset	Clear alarm after cause has been fixed. When there is no alarm to clear, this key sets the active pump's profile to Stop. Also used to cancel data entered and return to original data.
 	Up Arrow- /Down Arrow	Move between screens or fields on a screen, highlight data to change, or to increase or decrease the digits in a field.
	Enter	Activate a field for editing or accept the highlighted selection on a menu.
	Enter Screen	Highlight data that can be edited. Also can change the function of the Up/Down arrows so they move between data fields on the screen, rather than between screens.
	Exit Screen	Exit data editing.

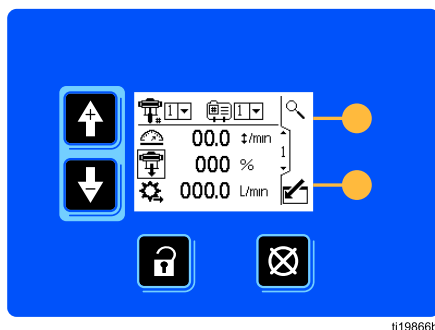

Figure 47 Control Module Keypad and Display

## Set Up a Pump Control Module for Modbus Communication

Follow these steps to set up a Pump Control Module (PD) using the keypad and display. For complete warnings and operation instructions, see the E-Flo DC Control Module Kit manual 3A2527.

- Press the Enter key to enter each setting.
  - Press the Up Arrow or Down Arrow key to select the settings for the pump.
  - Press the Enter key to enter the selection for the setting.
1. Press the Toggle key to enter the control module Setup screens.
  2. Use the Up Arrow and Down Arrow keys to navigate to Setup Screen 14.

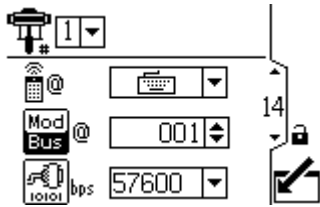

Figure 48 Setup Screen 14

3. Confirm that Pump 1 is displayed on the Pump No. menu . If not, highlight the menu and select 1.

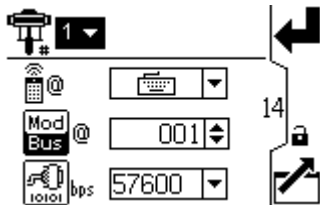

Figure 49 Setup Screen 14 Pump Menu

4. Select a control location (local or remote) from the menu.

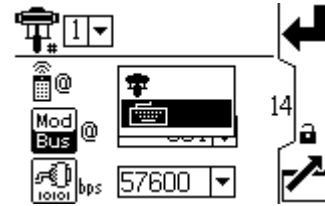

Figure 50 Setup Screen 14 Local or Remote Control Location Menu

5. Set the Modbus node ID from 1 to 247.

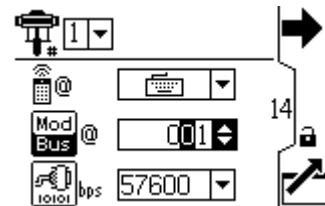

Figure 51 Setup Screen 14 Modbus Node ID Field

6. Select the serial port baud rate from the menu. 57600 bps is standard. 38400 is also available. Do not select 115200 because it is not compatible with the Supervisor Module.

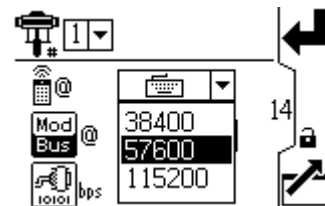

Figure 52 Setup Screen 14 Baud Rate Menu

7. When all control module settings are correct, press the Exit Screen key to exit setup mode.



## Set Up a Tank Control Module for Modbus Communication

Follow these steps to set up a Tank Control Module (TD) using the keypad and display. For complete warnings and operation instructions, see the Tank Control Module Kit manual 3A5991.

- Press the Up Arrow or Down Arrow key to select the settings for the tank
  - Press the Enter key to enter the selection.
1. Press the Toggle key to enter the control module Setup screens.
  2. Use the Up Arrow and Down Arrow keys to navigate to Setup Screen 5.

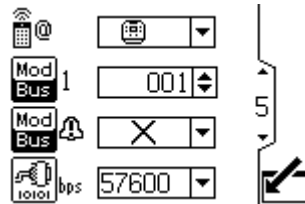



Figure 53 Setup Screen 5

3. Select a control location (local  or remote ) from the menu.

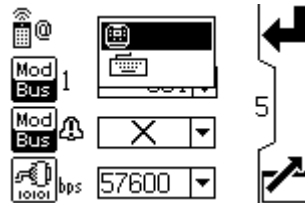

Figure 54 Setup Screen 5 Local or Remote Control Location Menu

4. Set the Modbus node ID from 1 to 247.

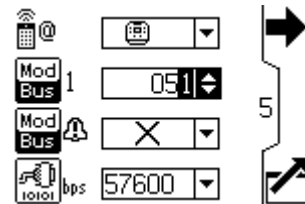

Figure 55 Setup Screen 5 Modbus Node ID Field

5. Select a Modbus communications failure notification type from the menu. Select X for disabled or  for deviation.



Figure 56 Setup Screen 5 Failure Notification Type Menu

6. Select the serial port baud rate from the menu. 57600 bps is standard. 38400 is also available. Do not select 115200 because it is not compatible with the Supervisor Module.





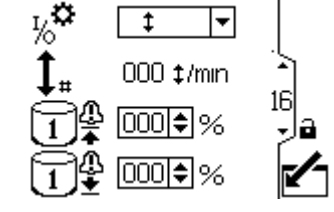

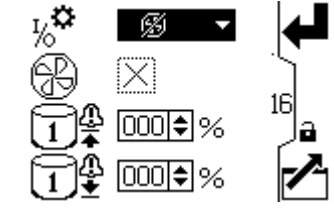



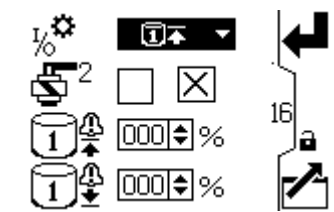



Figure 57 Setup Screen 5 Baud Rate Menu







7. When all control module settings are correct, press the Exit Screen key to exit setup mode.

### Set Up Pump Control Module Configurable I/O

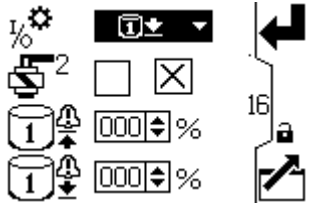
Use the Pump Control Module (PD) keypad and display to set up configurable inputs and outputs.

1. Press the Toggle key to enter the Setup screens of the Pump Control Module.
2. Use the Up Arrow and Down Arrow keys to navigate to Setup Screen 16.
3. Press the Enter Screen key to enter the screen and edit the settings.
4. Use the menu next to the I/O icon  to select the option for the connected peripheral.

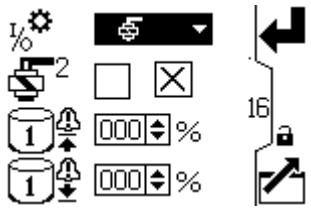

Option	Icon	Screen	Function
Reed Switch			Configures Port 4 pin 4 as an input to allow a reed switch to be connected.  The current reed switch cycle rate appears next to the cycle rate icon  in cycles per minute.
Agitator Halt Drum Cover Switch			Configures Port 4 pin 4 as an input to allow a pressure switch to be connected. If the drum cover is lifted while this configuration is properly connected, the agitator shuts down.  The current input status appears in the agitator status field   . A Supervisor Module is required for this function.
Primary Tank High Alarm Output			Configures Port 4 pin 4 as an output to allow for the connected device to receive an alarm when the volume of the Primary Tank is above the value that is defined in the Primary Tank High field   . This value is a percentage of the total volume of the Primary Tank.  Select the manual output box   and hold the button to control the output manually. After you release the button, the manual activation is terminated.

Option	Icon	Screen	Function
Primary Tank Low Alarm Output			<p>Configures Port 4 pin 4 as an output to allow for the connected device to receive an alarm when the volume of the Primary Tank is below the value that is defined in the Primary Tank Low field  %. This value is a percentage of the total volume of the Primary Tank.</p> <p>Select the manual output box  <input type="checkbox"/> <input checked="" type="checkbox"/> and hold the button to control the output manually. After you release the button, the manual activation is terminated.</p>
Auxiliary Solenoid			<p>Configures Port 4 pin 4 as an output to allow for another solenoid to be connected and controlled from the device.</p> <p>Select the manual output box  <input type="checkbox"/> <input checked="" type="checkbox"/> and hold the button to control the auxiliary solenoid manually. After you release the button, the manual activation is terminated.</p>

- When all control module settings are correct, press the Exit Screen key to exit setup mode.

### Set Up Tank Control Module Configurable I/O

Use the Tank Control Module (TD) keypad and display to set up configurable inputs and outputs.

1. Press the Toggle key to enter the Setup screens of the Tank Control Module.
2. Use the Up Arrow and Down Arrow keys to navigate to Setup Screen 3.
3. Press the Enter Screen key to enter the screen and edit the settings.
4. Use the menu next to the I/O icons  and  to select the option for the connected peripheral. Control the auxiliary solenoid by updating the information next to the icon .

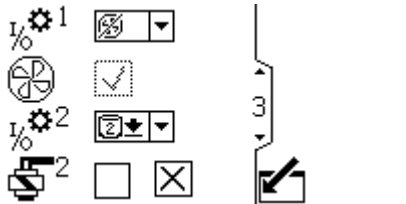















Figure 58 Setup Screen 3 (Agitator Halt and Secondary Tank Low Alarm Output Shown)

Setup Screen 3 Key	
	Select reed switch input  or agitator halt  to configure digital input for Port 4, Pin 2.
 	Agitator halt status or Reed switch cycle rate
	Select one of the following to configure digital input/output for Port 4, Pin 4 :   Reed Switch Input  Primary Agitator Halt Input  Primary Tank High Alarm Output  Primary Tank Low Alarm Output  Secondary Tank Low Alarm Output  General Purpose Output
	Select the manual output box  and hold the button to control the auxiliary solenoid manually. After you release the button, the manual activation is terminated.

5. When all control module settings are correct, press the Exit Screen key to exit setup mode.

### Set Up a Radar Level Sensor Using the Keypad

Use this procedure to connect a Radar Level Sensor (M, T) to a Pump Control Module (PD) or Tank Control Module (TD) using the keypad.

**NOTE:** The following steps describe connections to a Graco-approved Radar Level Sensor. If you are not using a Graco-approved Radar Level Sensor, contact your distributor.

1. Set up the primary Pump Control Module and primary Tank Control Module.
  - a. For the primary Pump Control Module, turn on power to Port 9 using setup screen 17.

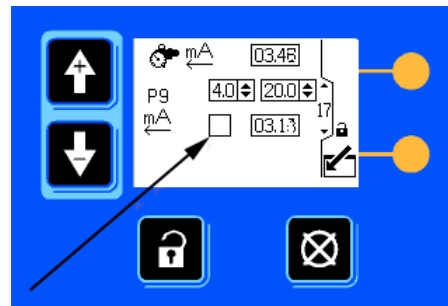

Figure 59 Turn on Power for the Primary Pump Control Module

- b. For the primary Tank Control Module, turn on power to Port 8 using setup screen 1.

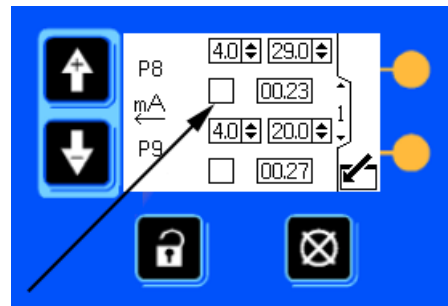

Figure 60 Turn on Power for the Primary Tank Control Module

2. Set up the secondary Tank Control Module. Turn on power to Port 9 using setup screen 1.

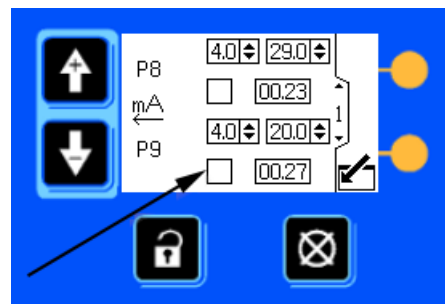

Figure 61 Turn on Power for the Secondary Tank Control Module

## Configure the Radar Level Sensor

**NOTE:** See [Appendix I: VEGAPULS 64 Tank Level Sensor Menu, page 170](#), for information about the VEGAPULS 64 Sensor.

Use this procedure to configure Graco part numbers 25D298 and 25D294 (Endress+Hauser FMP50 Radar Level Sensors).

**NOTE:** For complete warnings and operation instructions, see the manufacturer’s manual that is shipped with the product.

Key	Name	Function
-	Minus key	For menus and submenus, press this key to move the selection bar up in a list.  For text and numeric fields, press this key to move the selection bar to the left (backward).
+	Plus key	For menus and submenus, press this key to move the selection bar down in a list.  For text and numeric fields, press this key to move the selection bar to the right (forward).

Key	Name	Function
E	Enter key	Press this key to enter the setup screen (main menu).  Press this key for two seconds to open the context menu.  Press this key to open the selected menu, submenu, or parameter. Press the key for two seconds to open the help text for the selected parameter.  For text and numeric fields, press this key to open the selected group or perform the selected action. Press the key for two seconds on a selected parameter to confirm and enter the edited parameter value.
- and +	Es-cape key	For menus and submenus, press these two keys to exit the current menu level and go to the next higher level.  For help text, press these two keys to close the help text for a parameter.  Press these two keys for two seconds to return to the home screen.  For text and numeric fields, press these two keys to close the editor without applying changes.

Press E to enter the setup screen, press + to highlight the setup menu, and then press E to enter the setup menu. Enter the setup information for each screen.

Setup Screen	Function
Device tag	Enter a unique name for the measuring point.
Distance unit	Select the distance unit for calibration: <ul style="list-style-type: none"> <li>• Meters (default)</li> <li>• Millimeters</li> <li>• Feet</li> <li>• Inches</li> </ul>
Tank type	Select the tank type: <ul style="list-style-type: none"> <li>• Metallic</li> <li>• Bypass/pipe</li> <li>• Non-metallic</li> <li>• Mounted outside</li> <li>• Coaxial</li> </ul> NOTES: The <b>Medium type</b> must be <b>Liquid</b> for these options to be available. Depending on the probe, some options might not be available or additional options might appear. For coax probes and probes with a metallic center washer, the tank type corresponds to the type of probe and cannot be changed.
Medium group	Select the medium group to specify the dielectric constant (DC) of the medium: <ul style="list-style-type: none"> <li>• Water based (DC &gt;=4)</li> <li>• Others</li> </ul> NOTES: The <b>Medium type</b> must be <b>Liquid</b> for these options to be available. The <b>Medium property</b> can be changed later; however, the <b>Medium group</b> remains the same. The measuring range can be reduced for small dielectric constants.
Empty calibration	Enter the distance (LN) between the process connection (LR) and the minimum level (0%).

Setup Screen	Function
Full calibration	Enter the distance (LF) between the minimum (0%) and the maximum level (0%). The minimum is the bottom of the probe and the maximum is the "full" level.
Level	Displays the measured level (LL) of the material before linearization. The unit is defined in the Level unit setting.
Distance	Displays the distance (LD) between the lower edge of the flange or threaded connection (LR) and the level (LL).
Signal quality	Displays the signal quality of the evaluated echo. <ul style="list-style-type: none"> <li>• Strong: Exceeds the threshold by 10 mV or more.</li> <li>• Medium: Exceeds the threshold by 5 mV or more.</li> <li>• Weak: Exceeds the threshold by less than 5 mV.</li> <li>• No signal: The device cannot find a usable echo. The system displays an error message for output echo lost.</li> </ul> NOTE: The signal quality refers to the level/interface echo or the end-of-probe echo. The quality of the end-of-probe echo is displayed in brackets.
Confirm distance	Specify whether the measured distance matches the actual distance. <ul style="list-style-type: none"> <li>• Manual map: The range of mapping is defined manually in the <b>Mapping end point</b> parameter.</li> <li>• Distance OK: The measured distance matches the actual distance.</li> <li>• Distance unknown: The actual distance is unknown.</li> <li>• Distance too small: The measured distance is less than the actual distance.</li> <li>• Distance too big: The measured distance is more than the actual distance.</li> <li>• Tank empty: The tank is completely empty.</li> <li>• Delete map: Delete the present mapping curve.</li> </ul>

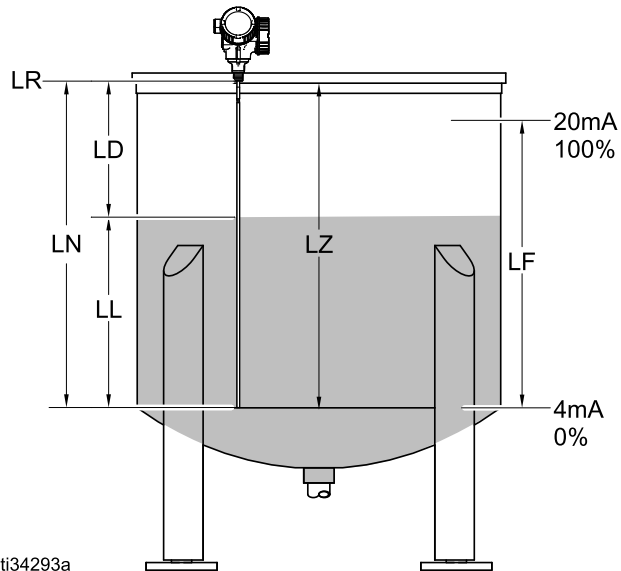

ti34293a

Figure 62 Configuration Parameters

Ref.	Description
LD	Distance
LF	Full calibration (span)

Ref.	Description
LL	Level
LN	Length of probe
LR	Reference point of the measurement
LZ	Empty calibration (zero point)

## Map an Empty Tank

**NOTE:** You must map the tank when it is empty to ensure that it functions properly.

Use this procedure to map an empty tank.

1. Press **E** to enter the setup screen.
2. Press **+** to highlight **Confirm distance** and then press **E** to enter the **Confirm distance** screen.
3. Press **+** to highlight **Delete map** and then press **E**.
4. Press **+** to highlight **Tank empty** and then press **E**.
5. Press **+** and **-** until you reach the main menu.

## Set Up a Lenze Variable Frequency Drive/Inverter for Modbus Communication

**NOTE:** This procedure is only for setting up a Variable Frequency Drive/Inverter manufactured by Lenze (Graco part numbers 17N041, 17N042, and 17N043). For Variable Frequency Drives/Inverters made by a different company, see their documentation for complete warnings and operation instructions.





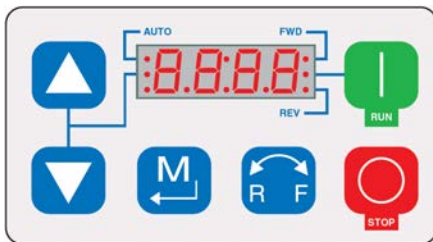

Use this procedure to enter the node ID that the Intelligent Paint Kitchen software assigned for each Variable Frequency Drive/Inverter (B) in the system. In addition to setting the node ID, each Variable Frequency Drive/Inverter must be individually configured to take the Variable Frequency Drive/Inverter out of Local mode and set it to communicate with the Intelligent Paint Kitchen software.

When this procedure has been completed, Variable Frequency Drive/Inverter settings and operation are controlled from the Intelligent Paint Kitchen software, with no local control at the Variable Frequency Drive/Inverter display and keypad.



### Operating the Variable Frequency Drive/Inverter Keypad

The following steps require you to program information directly into a Lenze Variable Frequency Drive/Inverter. Use these guidelines to operate the Variable Frequency Drive/Inverter keypad:

1. Press  to put the Variable Frequency Drive/Inverter in Program mode.
2. Use the  and  keys to navigate to each P-code, as instructed.
3. When the P-code appears, press  to go into that P-code.
4. Use the  and  keys to set that P-code as instructed.
5. When the P-code has been set, press  again to return to the P-code screen. Then continue to the next P-code to be set.



### Using the Lenze Keypad and Display

1. On the Lenze Variable Frequency Drive/Inverter keypad, press  to go into Program mode.
2. Set the P-codes to the following (**NOTE:** all P-code settings must be entered for the frequency drive/inverter to operate correctly):

P-code	Setting	Description
P100 Start Control Source	03	Network Only
P101 Standard Reference Source	06	Network
P102 Minimum Frequency	0.0	Hertz
P103 Maximum Frequency	60.0	Hertz
P121 TB-13A Digital Input	09	Network Enable
P122 TB-13B Digital Input	21	External Fault  <b>NOTE:</b> Wire in a motor thermal overload switch. The Variable Frequency Drive/Inverter will error out if the thermal overload switch from the agitator is not wired in.  <b>NOTE:</b> If no thermal overload switch is used, set the value to 0 to prevent External Fault.
P194 Password	0	Allows the Supervisor Module to control the Variable Frequency Drive/Inverter.
P400 Network Protocol	02	Modbus RTU
P410 Network Address	101–120 for a primary agitator 121–140 for a secondary agitator	Set to the node ID generated by the Intelligent Paint Kitchen for this Variable Frequency Drive/Inverter.
P411 Network Baud Rate	05	57600 bps
P412 Network Data Format	0.0	8 data bits, no parity, 2 stop bits
P425 Network Message Time Out	10.0	Generate an Intelligent Paint Kitchen error after 10 seconds of no data.
P426 Network Message Time Out Action	1.0	If a timeout occurs, Variable Frequency Drive/Inverter halts the motor it controls.

## Variable Frequency Drive/Inverter Nodes

On each primary Variable Frequency Drive/Inverter and secondary Variable Frequency Drive/Inverter, use the control panel to enter the node ID that was assigned when the station was configured.

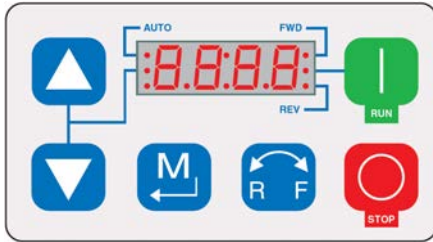

Example: Lenze Variable Frequency Drive/Inverter control panel shown.

Press  to access the Variable Frequency Drive/Inverter menu. See [Set Up a Lenze Variable Frequency Drive/Inverter for Modbus Communication, page 56](#) to set the Variable Frequency Drive/Inverter parameters as required for use with the Intelligent Paint Kitchen. See the manufacturer's instructions for complete menu descriptions and information.

**NOTE:** Entering the correct node ID into each Variable Frequency Drive/Inverter allows the Intelligent Paint Kitchen software to communicate with each Variable Frequency Drive/Inverter. It does not tell the Variable Frequency Drive/Inverter the speed of each agitator motor during operation. You can use the Intelligent Paint Kitchen software to enable or disable each agitator in a station and to set its operating speed.

**NOTE:** Each Lenze Variable Frequency Drive/Inverter must have a jumper installed. For connection information, see [Variable Frequency Drive/Inverter Connections, page 29](#). If the Variable Frequency Drive/Inverter was purchased from Graco, the jump is pre-installed. But if the Variable Frequency Drive/Inverter was purchased from a different supplier, you must install the jumper.

# Touchscreen Software

Use the Touchscreen software to enter information and display software settings and current conditions in the Intelligent Paint Kitchen system. The software is located in the Supervisor Box (A), but the data input and readout is displayed on the Touchscreen Box (J).











- Use the Setup screens to configure the Intelligent Paint Kitchen system and its components.
- Use the Run screens to control the system and view current system information.

## Touchscreen Icons

The following icons appear along the bottom of the Stations screen and other Run screens.

<b>NOTICE</b>
To prevent damage to the Touchscreen interface, do not press the screens with sharp objects such as pens, plastic cards, or fingernails.

**Table 2 : Touchscreen Icon Functions**

Icon	Screen	Function
	Production Schedule Screen	Displays the current production schedule for the system. See <a href="#">Manage Production Schedule, page 100</a> .
	Graphs Screen	Displays live and historical operational data for station components. See <a href="#">View the Graphs Screen, page 102</a> .
	Stations Screen	Displays an overview of station component status. Use this screen to navigate to detailed screens for each component. See <a href="#">View the Stations Screen, page 104</a> .
	Pumps Screen	Displays the status of every pump in the system. Current pressure, flow and speed data can be viewed for each pump. See <a href="#">View the Pumps Screen, page 118</a> .
	Tanks Screen	Displays the current fluid level and agitator speed for every Primary Tank and fill drum in the system. See <a href="#">View the Tanks Screen, page 120</a> .
	Event Log	Displays Intelligent Paint Kitchen advisories, deviations, and alarms. See <a href="#">View the Event Log, page 124</a> .
	Setup Menu	Creates and configures stations and components. See <a href="#">Using the Setup Screens, page 63</a> .
	Return	Return to the previous screen.
	Locked	Indicates whether the currently displayed screen is locked or unlocked. Locked screens require password entry to access or change settings.
	Unlocked	Use these icons to lock or unlock the software screens, depending if you want to require a password to access the screen. See <a href="#">Lock or Unlock Setup Screens, page 90</a> .

## Onscreen Controls

When you power up, the Graco logo displays for approximately five seconds, followed by the Stations screen. To begin, press one of the icons along the bottom of the screen.









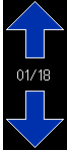

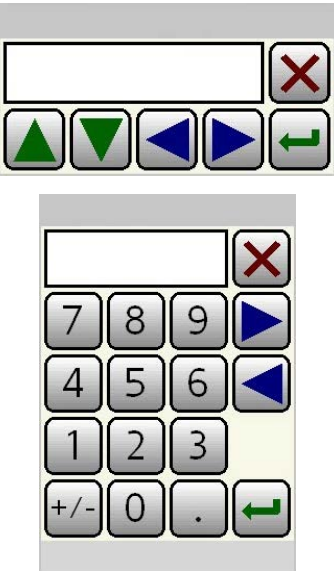
After five seconds of inactivity, the screensaver causes the Touchscreen interface to appear dark when no actions are being performed. To activate the Touchscreen interface again, press anywhere on the screen. You can adjust the number of seconds on the Screensaver Configuration screen, accessed through the Settings menu.

Navigate through the software by pressing buttons, keys, fields, and icons with your finger. Pressing any of the controls on the screen brings you to another screen or displays a popup screen that requires your input.

**NOTE:** Selection fields and buttons that are grayed out on the screens are not currently active.

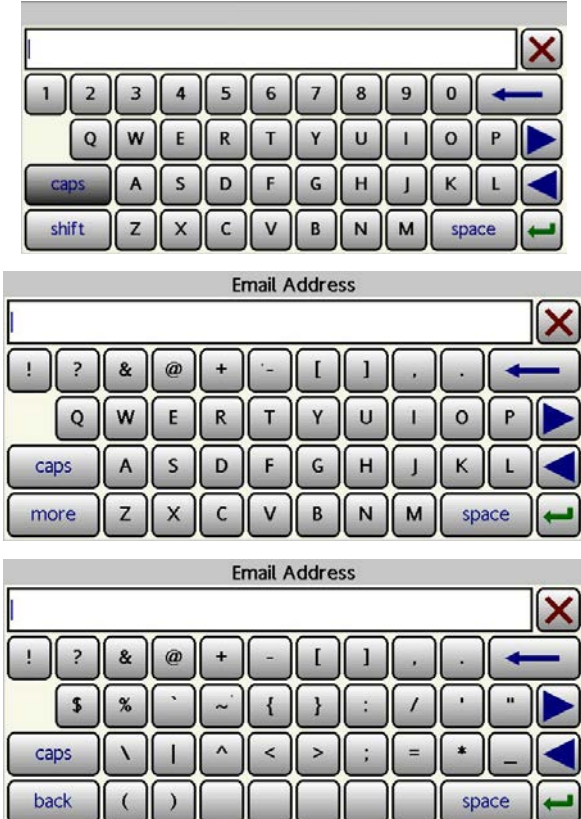
**Table 3 Touchscreen Controls**

Ref.	Description
	<p>Located below the Touchscreen:</p> <p>— indicates that an SD card is inserted into the Touchscreen.</p> <p>Press 🏠 to return to the Stations screen.</p>
	<p>Screens whose content does not fit on the Touchscreen interface have up and down arrow icons. Press an arrow to page up or page down within the screen.</p>

Ref.	Description
	<p>Popup screens appear when you need to select a command, enter a numerical value, or specify whether a condition exists. For example, selecting <b>Yes</b> or <b>No</b>, and turning a component on or off. When a number is required, the popup has a numerical keypad.</p> <p>Popup screens have the following controls:</p> <ul style="list-style-type: none"> <li>• Press the green up and down arrows   to move to the previous or next editable field on the current screen.</li> <li>• Press the blue left and right arrows   to move through the available choices for the current field.</li> <li>• Press Cancel  once to return to the previous value in the field. Press Cancel twice to close the popup screen without changing any values.</li> <li>• Press Return  to keep the entered values and close the popup screen.</li> <li>• Numeric keypads display the range of valid entries. Only valid entries are accepted when you press Return.</li> </ul>
	<p>An onscreen keyboard displays when text input is needed (for example, when entering a name for each station in your system). Press the keys to enter text in the popup window.</p> <ul style="list-style-type: none"> <li>• Use the blue left and right arrows   to move to the previous or next editable field on the current screen.</li> <li>• Use Backspace  to move the cursor backward and edit the displayed text as needed.</li> <li>• Press Return  to select the displayed text and enter it into the software.</li> </ul> <p><b>NOTE:</b> Press Shift to type capital letters. The Shift key changes into a More key, which you can press to view and type special characters.</p>

## Viewing the Navigation Path

You can access many of the Intelligent Paint Kitchen software screens using many different navigation paths. You can generally start by pressing one of the Run screen icons along the bottom of the Touchscreen interface.

For example, you could navigate to the Primary Agitator Status screen either from the Stations screen

or from the Station Status screen. Depending on which Run screen icon is highlighted in green, you know the path you took to get there.

For ease of navigation, the Run screen icon that you pressed is highlighted in green.

Press  one or more times to return to the Run screen.

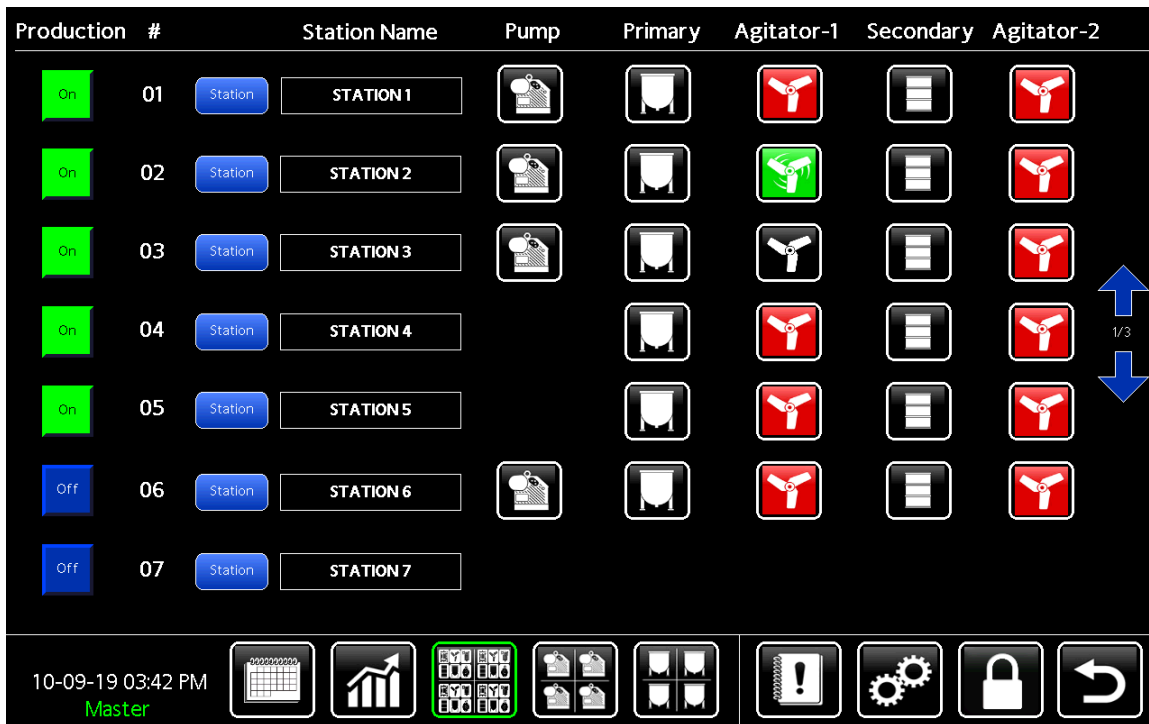

Figure 63 Screen Navigation Path

# Using the Setup Screens

Initial setup of an Intelligent Paint Kitchen requires you to enter the physical specifications of your stations and their components into the Intelligent Paint Kitchen software:

- Create and name each station (required).
- Enter specifications of every component of each station (required).
- Create and enter node IDs to allow the Intelligent Paint Kitchen software to communicate with the station components (required).
- Enter operating specifications for each pump and agitator (required).
- Create profiles for every pump, Variable Frequency Drive/Inverter, and agitator in the system (required). Multiple profiles allow the Intelligent Paint Kitchen software to select the profile that causes a component to operate as needed for current conditions.
- Lock or unlock access to the setup parameters (optional).
- Set a password (optional).

## Using the Setup Menu

Most system setup tasks are accessed through the Setup Menu screen.



Press  on any Run screen to enter the Setup menu screen.

If the system has a password lock, the Password screen displays. See [Enter Password, page 97](#).

Use instructions on the following pages to access and perform setup functions from the Setup Menu. In general, a new Intelligent Paint Kitchen system is set up by clicking the Setup Menu buttons. Start at the upper left with Station Configuration and complete each row, working from left to right.

Button	Description
Station Configuration	Press to display the Station Configuration screen, used to set up each station in the Intelligent Paint Kitchen installation. Use this screen to specify the components that are installed, and node IDs where needed. Follow the procedure in <a href="#">Configure Each Station, page 66</a> .
Node Communication	Press to display the Node Communication screen, used to perform these functions: <ul style="list-style-type: none"> <li>• Set up pump control nodes. See <a href="#">Pump Control Module Nodes, page 46</a>.</li> <li>• Set up tank control nodes. See <a href="#">Tank Control Module Nodes, page 46</a>.</li> <li>• Set up Variable Frequency Drive/Inverter nodes. See <a href="#">Variable Frequency Drive/Inverter Nodes, page 58</a>.</li> </ul>
E-Flo DC	Press to display the Pump Setup screen, used to set up each pump's specifications and units of measure, and those of the agitator and back pressure regulator associated with each pump. Also, use to specify whether each pump is controlled locally or remotely. Follow the procedure in <a href="#">Create Pump Profiles, page 87</a> .
Tank Control	Press to display the Pumpless Setup screen, used to set up units of measure for each Secondary Tank and its associated agitator. Also, use to specify whether each pneumatic remote transfer pump is controlled locally or remotely. Follow the procedure in <a href="#">Set Up Tank Control Modules, page 73</a> .
Primary Tank	Press to display the Primary Tank Control Setup screen, used to set operating units and parameters for supplying fluid from the Secondary Tank to the Primary Tank. Follow the procedure in <a href="#">Set Up Tank Control Modules, page 73</a> .
Secondary Tank	Press to display the Secondary Tank Control Setup screen, used to set operating units and parameters for supplying fluid from the Primary Tank to the Secondary Tank. Follow the procedure in <a href="#">Set Up Tank Control Modules, page 73</a> .
Profiles	Press to display the Profiles screen, used to create multiple profiles that specify operating parameters for each pump in the system. See <a href="#">Create Pump Profiles, page 87</a> .
Scheduler	Press to display the Production Scheduler screen, used to create production schedules for the system. See <a href="#">Set Up Production Schedule, page 91</a> .

Button	Description
Supervisor Configuration	<p>Press to display the Supervisor Configuration screen, used to access these Intelligent Paint Kitchen software functions:</p> <ul style="list-style-type: none"> <li>• View the status of each Supervisor Box in the system.</li> <li>• View or edit the IP address and the subnet mask, and the gateway used by the Supervisor network.</li> <li>• Ping the Supervisor network to confirm communication.</li> </ul> <p>For more information, see <a href="#">Configure the Supervisor Module, page 95</a>.</p>
HMI Configuration	<p>Press to display the Display Configuration screen, used to view or edit the Modbus/TCP network configuration for port 1 and port 2. Follow the procedure in <a href="#">Configure the Display, page 94</a>.</p>
Email	<p>Press to display the Email Setup screen, used to specify email addresses to which notification of system events are sent. Follow the procedure in <a href="#">Set Up Notifications, page 92</a>.</p>
Expansion I/O	
Settings	<p>Press to set the language, screen saver, time format, and time settings; and to access the Utilities, Versions, and Diagnostic menus.</p> <ul style="list-style-type: none"> <li>• Press <b>Screen Saver</b> to set up the screen saver on the Touchscreen interface. Use this feature to set the inactive time after which the screen saver is displayed.</li> <li>• Set the time and the date. See <a href="#">Set the Time and Date, page 139</a>.</li> <li>• Press <b>Utilities</b> to display the Utilities Menu screen, used to access these Intelligent Paint Kitchen software functions: <ul style="list-style-type: none"> <li>– Format and use an SD card in the Touchscreen Module. See <a href="#">Use an SD Card, page 138</a>.</li> <li>– Format and use a USB drive in the Touchscreen Module. See <a href="#">Use a USB Drive, page 138</a>.</li> <li>– Test the Touchscreen interface to see if calibration is needed. Format and use an SD card in the Touchscreen Module. See <a href="#">Test the Touchscreen Interface, page 136</a>.</li> <li>– Calibrate the Touchscreen interface. See <a href="#">Calibrate the Touchscreen Interface, page 137</a>.</li> </ul> </li> <li>• Press <b>Versions</b> to display the Versions screen, used to view the current version numbers of the software used by the Intelligent Paint Kitchen, the Pump Control Modules, and the Tank Control Modules. Follow the procedure in <a href="#">View Software Versions, page 136</a>.</li> <li>• Press <b>Diagnostic</b> to display the Diagnostic Menu screen, used to view and check diagnostic information for a selected station.</li> </ul>
Password	<p>Press to create a password to prevent unauthorized users from changing Intelligent Paint Kitchen settings. See <a href="#">Create a Password, page 97</a> to set up or change the password. See <a href="#">Enter Password, page 97</a> to access password-protected screens.</p>



## Setup Prerequisites

Before beginning these setup procedures, all paint kitchen components must meet these conditions:

- All components must be installed, both in the non-hazardous location and in the hazardous location.
- Communication must be established between components.
- Software must be installed in the control modules.
- You must know and understand how each station is configured and exactly what components are installed in each station.



## Create the Stations

Begin the setup process by entering the number of stations in the system.

The system creates each station and assigns a number (1–20) that corresponds to each station.

1. Press  on any Run screen to enter the Setup Menu screen.

The **Number of Stations** field indicates the number of stations that currently exist.

2. Press inside the  area of the screen.
3. On the Number of Stations popup screen, use the keypad to enter the number of stations in the Intelligent Paint Kitchen installation (1–20), then press the Return key .
4. If stations are added later, repeat steps 1–3, entering the total number of stations in the system.

## Configure Each Station

When the stations have been created ( [Create the Stations, page 65](#) ), each station must be individually configured.

Use this procedure to specify the equipment installed in one specific station. If the system contains multiple stations, use this procedure separately for each station.

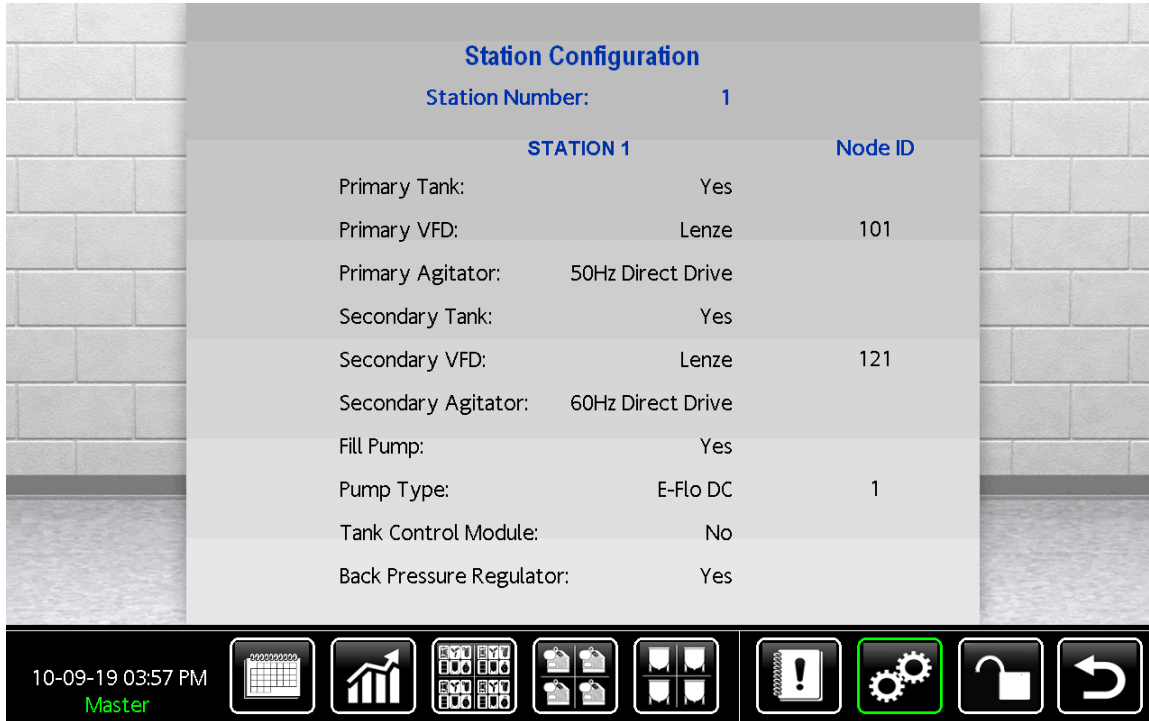



Figure 64 Station Configuration Screen

1. Press  on any Run screen to enter the Setup menu screen.
2. Press **Station Configuration**.
3. On the Station Configuration screen, press the **Station Number** field.  
NOTE: For a newly created station, all fields on the Station Configuration screen contain **No** or **None**.
4. On the **Station Number** keypad, enter the number of the station to be configured.

5. One at a time, press each item's response field and use the keypad to specify the equipment used in the selected station.  
For a list of field descriptions, see [Fields on the Station Configuration Screen](#).
6. A node ID is automatically generated for each paint kitchen component that communicates directly with the Intelligent Paint Kitchen software.  
Make a note of each node ID and the component for which it was created. Enter each ID its component, following the instructions in [Enter the Node IDs, page 45](#).
7. Repeat steps 3–6 for each additional station in the system.

Table 4 Fields on the Station Configuration Screen

Field	Description
Primary Tank	Select <b>Yes</b> if the station has a Primary Tank. Select <b>No</b> if there is no Primary Tank installed.
Primary VFD	Select the manufacturer of the Variable Frequency Drive/Inverter used to control the agitator installed on the Primary Tank: <b>Lenze</b> or <b>PowerFlex 4M</b> . See <a href="#">Variable Frequency Drive/Inverter (B) 17N041, 17N042, 17N043, page 17</a> for supported Variable Frequency Drives/Inverters. Select <b>None</b> if there is no Variable Frequency Drive/Inverter for the Primary Tank.
Primary Agitator	Select the type of agitator installed on the Primary Tank: <ul style="list-style-type: none"> <li>• <b>60 Hz Direct Drive</b></li> <li>• <b>60 Hz Back Gear</b></li> <li>• <b>50 Hz Direct Drive</b></li> <li>• <b>50 Hz Back Gear</b></li> <li>• <b>60 Hz Custom</b></li> <li>• <b>50 Hz Custom</b></li> </ul> For part numbers, see <a href="#">Appendix F: Agitator Part Numbers, page 163</a> . Select <b>None</b> if no agitator is installed.
Secondary Tank	Select <b>Yes</b> if the station has a Secondary Tank. Select <b>No</b> if there is no Secondary Tank installed.
Secondary VFD	Select the manufacturer of the Variable Frequency Drive/Inverter used to control the agitator installed on the Secondary Tank: <b>Lenze</b> or <b>PowerFlex 4M</b> . See <a href="#">Variable Frequency Drive/Inverter (B) 17N041, 17N042, 17N043, page 17</a> for supported Variable Frequency Drives/Inverters. Select <b>None</b> if there is no Variable Frequency Drive/Inverter for the Secondary Tank.
Secondary Agitator	Select the type of agitator installed on the Secondary Tank: <ul style="list-style-type: none"> <li>• <b>60 Hz Direct Drive</b></li> <li>• <b>60 Hz Back Gear</b></li> <li>• <b>50 Hz Direct Drive</b></li> <li>• <b>50 Hz Back Gear</b></li> <li>• <b>60 Hz Custom</b></li> <li>• <b>50 Hz Custom</b></li> </ul> For part numbers, see <a href="#">Appendix F: Agitator Part Numbers, page 163</a> . Select <b>None</b> if no agitator is installed.
Fill Pump	Select <b>Yes</b> if a pneumatic remote transfer pump is used to fill the Primary Tank from the Secondary Tank. Select <b>No</b> if there is no transfer pump installed.
Pump Type	Select the type of pump used to circulate fluid through the station: <b>None</b> , <b>E-Flo DC</b> , or <b>E-Flo DC x 2</b>
Tank Control Module	Select <b>Yes</b> if the Secondary Tank has a Tank Control Module. Select <b>No</b> if there is no Tank Control Module.
Back Pressure Regulator (BPR)	Select <b>Yes</b> if the station has an installed back pressure regulator. Select <b>No</b> if there is no back pressure regulator installed.

## Name Each Station

When the stations were created using the Intelligent Paint Kitchen software ( [Create the Stations, page 65](#)), each station was given a unique number. For example, if your installation contains ten stations, the stations are numbered 1 through 10.

Give each station a descriptive name. Typically, each station's name is that of the paint color or fluid used at that station (Red, Blue, Light Grey, and so on).

Be certain that you know which physical station is represented by each station number. This is determined by which Supervisor Box (A) and which fiber optic converter each station is physically connected to.

For example, if your system has 14 paint kitchens, stations 1–10 might be connected to the Supervisor Box, and stations 12–14 might be connected to the Expansion Box.

**NOTE:** These instructions assume that you have connected a fiber optic cable from each station to a fiber optic converter before creating and naming the stations. You could also do this in the opposite order by first creating the stations in the Intelligent Paint Kitchen software, then naming each station, and then connecting each fiber optic converter to the corresponding station. Each physical station must be connected to the one fiber optic converter that matches the station number generated by the software.

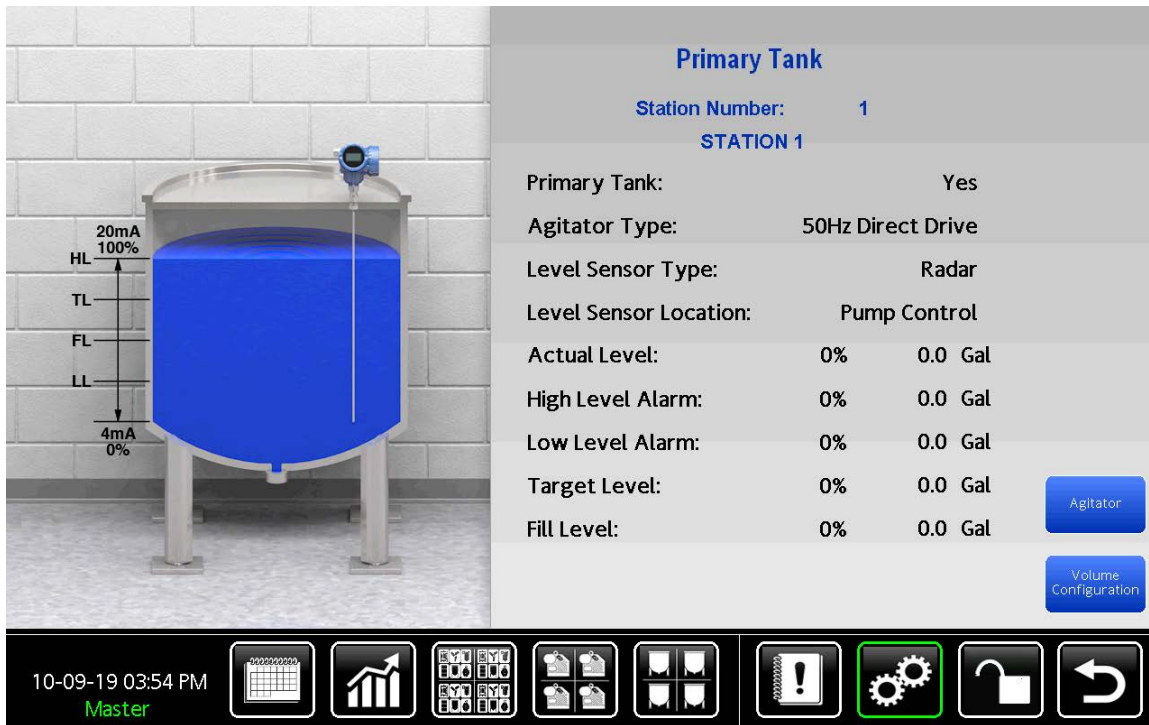



Figure 65 Primary Tank Screen

1. Press  on any Run screen to enter the Setup menu screen.
2. Press the **Station Name** field. **NOTE:** The screen must be unlocked for you to enter the station name.
3. Use the **Station Name** keyboard to enter a name for the selected station.

**NOTE:** Station names can include upper-case and lower-case letters, spaces, numerals, and special characters. Press Shift to access upper-case letters, then press More to access special characters.

4. When you have finished typing the station name, press Return .
5. Repeat steps 3–6 for each station that has been created.
6. After naming all the stations, go to [Configure Each Station, page 66](#) to continue setting up the system.

## Turn on Node Communication

After entering the generated node IDs into each Variable Frequency Drive/Inverter, each Pump Control Module, and each Tank Control Module, turn on communication between the Intelligent Paint Kitchen software and each of those components.

Each component having a node ID must be powered up and communication cables must be connected between each component and the Supervisor Box.

1. Press  on any Run screen.
2. On the Setup menu screen, press **Node Communication**.
3. On the Node Communication screen, set each of the following items:
  - Press **Pump Control Nodes** to turn on communication to the Pump Control Modules.
  - Press **Tank Control Nodes** to turn on communication to the Tank Control Modules.
  - Press **VFD Nodes** to turn on communication to each Variable Frequency Drive/Inverter in the system.
    - Each primary Variable Frequency Drive/Inverter controls the speed of a Primary Tank agitator.
    - Each secondary Variable Frequency Drive/Inverter controls the speed of a Secondary Tank agitator.

4. Initially, the blue **Off** button indicates that all communication is turned off between the Intelligent Paint Kitchen software and the component (pump, Tank Control Module, or Variable Frequency Drive [Inverter]). Press the button to toggle it to **On** for the following:
  - Each station (#1–#20) in your system that has a pump
  - Each tank in your system
  - Each Variable Frequency Drive/Inverter in your system

The button turns green and the Intelligent Paint Kitchen software sends a signal to the pump to test the communication. If the button returns to blue (Off), the test signal failed and the connection could not be made. See [Troubleshooting, page 134](#) to find possible reasons and solve the problem.

**NOTE:** Buttons exist for all possible stations (20 total).

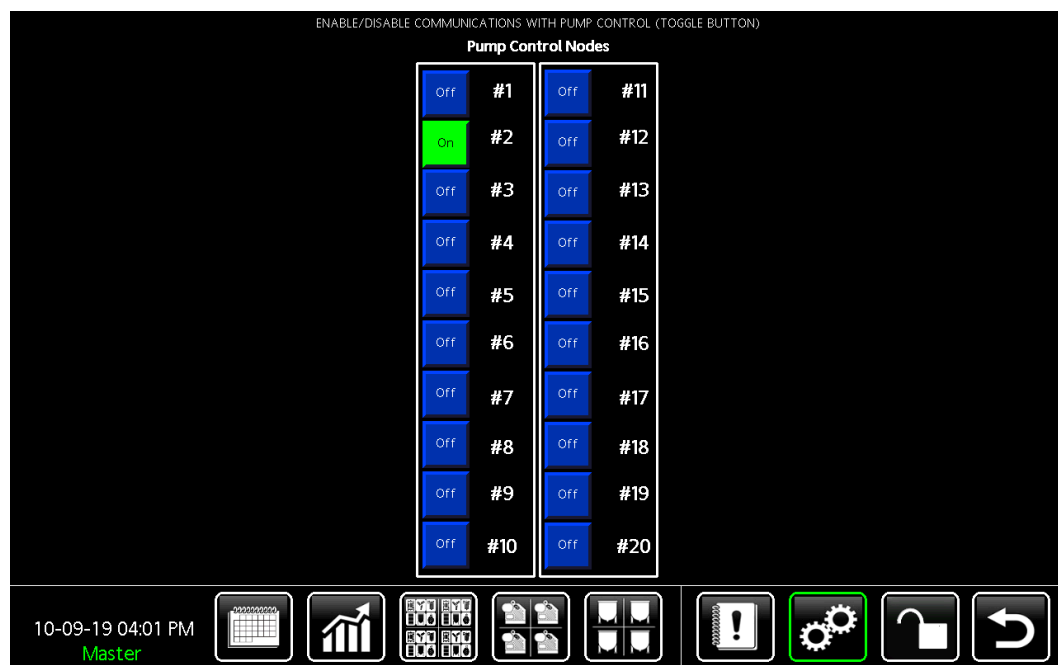

Figure 66 E-Flo DC Nodes Screen

## Set Up E-Flo DC Pumps

After turning on node communication to each component, each pump in the system must be individually configured. (Typically, each station contains one pump used to circulate fluid throughout that station.)

Use this procedure to specify the pump installed in one specific station. If the system contains multiple stations, use this procedure separately for the pump in each station.

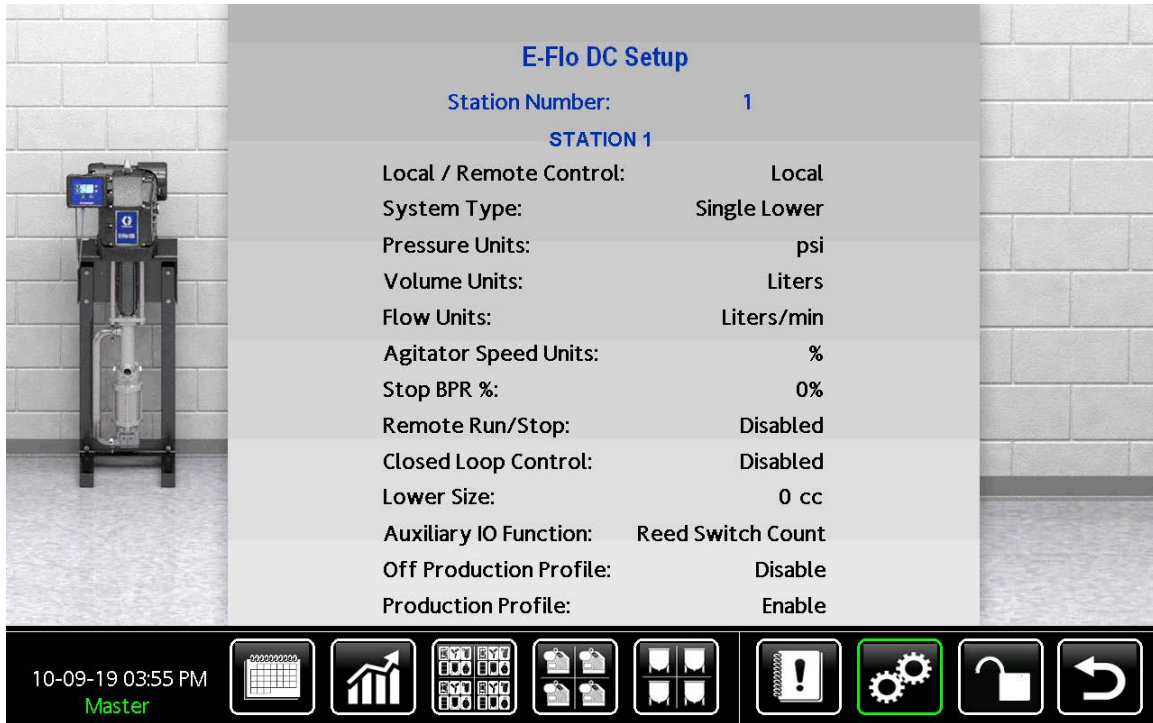



Figure 67 E-Flo DC Setup Screen

1. Press  on any Run screen to enter the Setup menu screen.
2. Press **E-Flo DC**.
3. On the E-Flo DC Setup screen, press the **Station Number** field.
4. On the **Station Number** keypad, enter the number of the station to be configured.

The number in the field is the station that is being configured in the following steps. The station name is displayed directly below the station number.

5. Press each item's response field and use the keypad that displays to specify the equipment used in the selected station. For a list of fields, see [Fields on the E-Flo DC Setup Screen](#).  
  
NOTE: For a newly-created station, all fields read **No** or **None**.
6. Repeat steps 3–5 for each additional pump in the system.

Table 5 Fields on the E-Flo DC Setup Screen

Field	Description
Station Number	The current station number being displayed: <ul style="list-style-type: none"> <li>• 1–Maximum number of stations</li> </ul>
Station Name	The alphanumeric name of the current station being displayed: <ul style="list-style-type: none"> <li>• 0–20 characters</li> </ul>
Local / Remote Control	Select <b>Local</b> to control the selected pump from the Pump Control Module in the hazardous location.  Select <b>Remote</b> to control the selected pump from the Intelligent Paint Kitchen software in the non-hazardous location.
System Type	Pump type is automatically detected and displayed: Single Lower or Dual Lower.
Pressure Units	Select the units for the pressure of the pump: <ul style="list-style-type: none"> <li>• <b>psi</b></li> <li>• <b>Bar</b></li> <li>• <b>MPa</b></li> </ul>
Volume Units	Select the units for the volume data of the pump: <ul style="list-style-type: none"> <li>• <b>Liters</b></li> <li>• <b>Gallons</b></li> <li>• <b>cc</b></li> </ul>
Flow Units	Select the units for the pressure flow data of the pump: <ul style="list-style-type: none"> <li>• <b>Liters/min</b>: Liters per minute</li> <li>• <b>Gallons/min</b>: Gallons per minute</li> <li>• <b>cc/min</b>: Cubic centimeters per minute</li> <li>• <b>oz/min</b>: Ounces per minute</li> <li>• <b>Cycles/min</b>: Cycles per minute</li> </ul>
Agitator Speed Units	Select the units for the agitator speed of the pump or tank: <ul style="list-style-type: none"> <li>• <b>%</b></li> <li>• <b>Hz</b></li> <li>• <b>RPM</b></li> </ul>
Stop BPR %	Enter a number (0–100) to specify the percentage of back pressure regulation to hold fluid line pressure when the pump is stopped.
Remote Run/Stop	Enable/Disable the Remote Run/Stop function.
Closed Loop Control	Enable/Disable the Closed Loop Control.
Lower Size	The pump lower size is automatically detected and displayed in cubic centimeters: 220 cc, 290 cc, 750 cc, 1000 cc, 1500 cc, 2000 cc, 3000 cc, or 4000 cc
Auxiliary I/O Function	Select the function: <ul style="list-style-type: none"> <li>• <b>Reed Switch Count</b>: Used to count the cycle rate of the fill pump.</li> <li>• <b>Agitator Halt</b>: When the pressure switch attached to the tank cover elevator closes, the pump control automatically disables the primary agitator.</li> <li>• <b>High Level Primary</b>: Enables output when the Primary Tank level is greater than the high level setting in percent.</li> <li>• <b>Low Level Primary</b>: Enables output when the Primary Tank level is less than the low level setting in percent.</li> <li>• <b>PLC</b>: Output control by a remote source.</li> </ul>

*Using the Setup Screens*

<b>Field</b>	<b>Description</b>
Off Production Profile	Enable/Disable Off Production mode on pump. <ul style="list-style-type: none"><li>• Profile 4 indicates Off Production station with no tank control</li><li>• Tank Fill is disabled</li><li>• Tank Freeze alarm is enabled</li></ul>
Production Profile	Enable/Disable Production profile. <ul style="list-style-type: none"><li>• Profile 1 becomes the production profile.</li></ul>



## Set Up Tank Control Modules

Each station may contain a Secondary Tank (H), used to provide fluid to the Primary Tank (G). Secondary Tanks may have any or all of a Radar Level Sensor (T), Agitator (R), and Pneumatic Remote Transfer Fill Pump (N) used to control the fluid supply operation. That set of components must be configured for each station.

Use this procedure to specify the Secondary Tank components installed in one specific station. If the system contains multiple stations, use this procedure separately for each station.



Figure 68 Tank Control Setup Screen

1. Press  on any Run screen to enter the Setup menu screen.
2. Press **Tank Control Module**.
3. On the Tank Control Setup screen, press the **Station Number** field.
4. On the **Station Number** keypad, enter the number of the station to be configured.

The number in the field is the station that is being configured in the following steps. The station name is displayed directly below the Station Number.

5. Press each item's response field and use the keypad that displays to specify the equipment used in the selected station. For a list of fields, see [Fields on the Tank Control Setup Screen](#).  
NOTE: For a newly-created station, all fields read **No** or **None**.
6. Repeat steps 3–6 for each additional station in the system.

**Table 6 Fields on the Tank Control Setup Screen**

Item	Description
Station Number	The current station number being displayed: <ul style="list-style-type: none"> <li>• 1–Maximum number of stations</li> </ul>
Station Name	The alphanumeric name of the current station being displayed: <ul style="list-style-type: none"> <li>• 0–20 characters</li> </ul>
Local / Remote Control	Select <b>Local</b> to control the selected agitator and tank fill logic from the Tank Control Module in the hazardous location.  Select <b>Remote</b> to control the selected agitator and tank fill logic from the Intelligent Paint Kitchen software in the non-hazardous location.
Pressure Units	Select the units for this remote transfer pump’s pressure to be displayed in: <ul style="list-style-type: none"> <li>• <b>psi</b></li> <li>• <b>Bar</b></li> <li>• <b>MPa</b></li> </ul>
Agitator Speed Units	Select the units for this Secondary Tank’s agitator speed to be displayed in: <ul style="list-style-type: none"> <li>• <b>%</b></li> <li>• <b>Hz</b></li> <li>• <b>RPM</b></li> </ul>
Flow Units	Select the units for this remote transfer pump’s flow data to be displayed in: <ul style="list-style-type: none"> <li>• <b>Liters/min</b></li> <li>• <b>Gallons/min</b></li> <li>• <b>cc/min</b></li> <li>• <b>oz/min</b></li> <li>• <b>Cycles/min</b></li> </ul>
Auxiliary Input Function	Select the function: <ul style="list-style-type: none"> <li>• <b>Reed Switch Count:</b> Used to count the cycle rate of the fill pump.</li> <li>• <b>Agitator Halt:</b> When the pressure switch attached to the tank cover elevator closes, the pump control automatically disables the primary agitator.</li> </ul>
Auxiliary IO Function	Select the function: <ul style="list-style-type: none"> <li>• <b>Reed Switch Count Input:</b> Used to count the cycle rate of the fill pump.</li> <li>• <b>Primary Agitator Halt Input:</b> When the pressure switch attached to the tank cover elevator closes, the pump control automatically disables the primary agitator.</li> <li>• <b>Primary Tank High Alarm Output:</b> Enables an alarm when the Primary Tank level is more than the high level setting.</li> <li>• <b>Primary Tank Low Alarm Output:</b> Enables an alarm when the Primary Tank level is less than the low level setting.</li> <li>• <b>PLC General Output:</b> Output control by a remote source.</li> </ul>

## Set Up Primary Tanks

Each station contains one Primary Tank (G) , which provides the fluid that is pumped throughout the circulation system. Every Primary Tank must be individually configured.

Use this procedure to specify the Primary Tank installed in one specific station. If the system contains multiple stations, use this procedure separately for the Primary Tank in each station.

**NOTE:** When Tank Volume is configured (see [Configure Primary Tank Volume, page 79](#)), the screen displays the estimated volume with the tank level percentage. When the Tank Volume is not configured, only the tank level percentage is displayed.

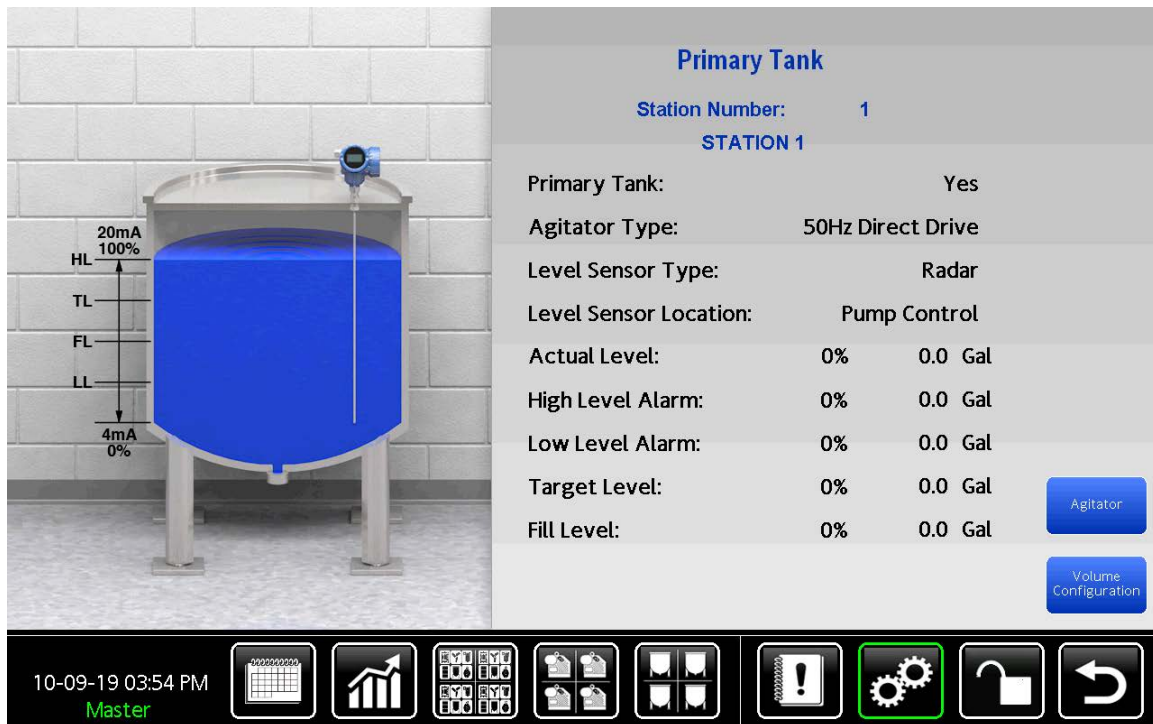



Figure 69 Primary Tank Screen

1. Press  on any Run screen to enter the Setup menu screen.
2. Press **Primary Tank**.
3. On the Primary Tank screen, press the **Station Number** field.
4. On the **Station Number** keypad, enter the number of the station to be configured.

The number in the field is the station that is being configured. The station name is displayed directly below the Station Number.

5. Press each item's data field and use the keypad that displays to specify the equipment used in the selected station. For a list of fields, see [Fields on the Primary Tank Setup Screen](#).

**NOTE:** For a newly-created station, all fields read **No** or **None**.

6. Repeat steps 3–6 for each additional station in the system.

**Table 7 Fields on the Primary Tank Setup Screen**

Item	Description
Station Number	The current station number being displayed: <ul style="list-style-type: none"> <li>• 1–Maximum number of stations</li> </ul>
Station Name	The alphanumeric name of the current station being displayed: <ul style="list-style-type: none"> <li>• 0–20 characters</li> </ul>
Primary Tank	Select <b>Yes</b> if the selected station has a Primary Tank. Select <b>No</b> if there is no Primary Tank installed.
Agitator Type	Select the type of agitator installed on the Primary Tank: <ul style="list-style-type: none"> <li>• <b>None</b> (Default)</li> <li>• <b>60 Hz Direct Drive</b> (Maximum frequency of 18 Hz)</li> <li>• <b>60 Hz Back Gear</b> (Maximum frequency of 43 Hz)</li> <li>• <b>50 Hz Direct Drive</b> (Maximum frequency of 18 Hz)</li> <li>• <b>50 Hz Back Gear</b> (Maximum frequency of 43 Hz)</li> <li>• <b>60 Hz Custom</b> (Maximum frequency of 60 Hz)</li> <li>• <b>50 Hz Custom</b> (Maximum frequency of 50 Hz)</li> </ul> For part numbers, see <a href="#">Appendix F: Agitator Part Numbers, page 163</a> . <b>NOTE:</b> When an Agitator Type is configured, the “Agitator” button appears. Use this button to navigate to the Primary Tank Agitator setup.
Level Sensor Type	Select the type of level sensor installed on this Primary Tank: <ul style="list-style-type: none"> <li>• <b>None</b> (Default)</li> <li>• <b>Radar</b></li> </ul> <b>NOTE:</b> When a Level Sensor Type is configured, the “Volume Configuration” button appears. Use this button to navigate to the Primary Tank Volume Configuration setup.
Level Sensor Location	Select the location where the Primary Tank radar sensor is plugged in: <ul style="list-style-type: none"> <li>• <b>None</b> (Default)</li> <li>• <b>Pump Control</b></li> <li>• <b>Tank Control</b></li> <li>• <b>Lenze</b></li> </ul>
Actual Tank Level	Displays the current fluid level in the Primary Tank. (Read Only)
High Level Alarm	Enter a number to specify the tank level (0–100%) at which a Tank Level High alarm is generated. <b>NOTE:</b> 0% disables the Tank Level High alarm.
Low Level Alarm	Enter a number to specify the tank level (0–100%) at which a Tank Level Low alarm is generated. <b>NOTE:</b> 0% disables the Tank Level Low alarm.
Target Level	When using a fill pump, enter a number to specify the fluid level at which the fill pump will turn off. <b>NOTE:</b> The Target Level must be less than the High Level Alarm and greater than the Fill Level.
Fill Level	Enter a tank level (0–100%) to trigger the fill pump to turn on.

## Set Up Primary Agitator



Figure 70 Primary Agitator Screen

1. Press  on any Run screen to enter the Setup menu screen.
2. Press **Primary Agitator**.
3. On the Primary Agitator screen, press the **Station Number** field.
4. On the **Station Number** keypad, enter the number of the station to be configured.

The number in the field is the station that is being configured. The station name is displayed directly below the Station Number.

5. Press each item's data field and use the keypad that displays to specify the equipment used in the selected station.

**NOTE:** For a newly-created station, all fields read **No** or **None**.

6. Repeat steps 3–6 for each additional station in the system.

**Table 8 Fields on the Primary Agitator Setup Screen**

Item	Description
Station Number	The current station number being displayed: <ul style="list-style-type: none"> <li>• 1–Maximum number of stations</li> </ul>
Station Name	The alphanumeric name of the current station being displayed: <ul style="list-style-type: none"> <li>• 0–20 characters</li> </ul>
Variable Frequency Drive	Select the manufacturer of the Variable Frequency Drive/Inverter used to control the agitator in the Primary Tank: <ul style="list-style-type: none"> <li>• <b>None</b> (Default)</li> <li>• <b>Lenze</b> (Lenze SMVector)</li> <li>• <b>AB PowerFlex 4M</b> (Allen Bradley PowerFlex 4M)</li> <li>• <b>AB PowerFlex 525</b> (Allen Bradley PowerFlex 525)</li> <li>• <b>Mitsubishi</b> (FR-F800 and FR-E700 series)</li> </ul> For Lenze part numbers, see <a href="#">Variable Frequency Drive/Inverter (B) 17N041, 17N042, 17N043, page 17</a> .
Agitator Profile	Select <b>Enable</b> to allow the primary tank agitator to be controlled by agitator profiles. Select <b>Disable</b> to disable agitator profiles. See <a href="#">Set Up Agitator Profile, page 89</a> , for more information about setting up agitator profiles.
Production Enable	Select <b>Enable</b> to enable the following features: <ul style="list-style-type: none"> <li>• When the system goes into production, it will monitor agitator status and trigger event if the agitator is idle for xx amount of time. (See the Idle Timer field below.)</li> <li>• If Agitator Profile is enabled, the agitator will automatically be pushed into profile 1 when in production, and profile 2 when not in production.</li> </ul> Select <b>Disable</b> to disable tracking of agitator idle time and scheduled control of profiles.
Idle Timer	Enter the number of minutes the agitator has not been running before a Primary Agitator Stopped (H1A0) event is triggered. Production Enable for this station has to be enabled for an event to trigger. <ul style="list-style-type: none"> <li>• 0–999 minutes</li> </ul> <b>NOTE:</b> When Idle Timer is set to 0, systems will not monitor agitator idle time while in production.

## Configure Primary Tank Volume



Figure 71 Primary Tank Configuration Screen

1. Press  on any Run screen to enter the Setup menu screen.
2. Press **Primary Agitator**.
3. On the Primary Agitator screen, press the **Station Number** field.
4. On the **Station Number** keypad, enter the number of the station to be configured.

The number in the field is the station that is being configured. The station name is displayed directly below the Station Number.

5. Press each item's data field and use the keypad that displays to specify the equipment used in the selected station.

**NOTE:** For a newly-created station, all fields read **No** or **None**.

6. Repeat steps 3–6 for each additional station in the system.

**Table 9 Fields on the Primary Tank Configuration Screen**

Item	Description
Station Number	The current station number being displayed: <ul style="list-style-type: none"> <li>• 1–Maximum number of stations</li> </ul>
Station Name	The alphanumeric name of the current station being displayed: <ul style="list-style-type: none"> <li>• 0–20 characters</li> </ul>
Tank Type	Select the primary tank type: <ul style="list-style-type: none"> <li>• <b>Unknown</b> (Default)</li> <li>• <b>Cylinder</b></li> </ul>
Volume Units	Select the unit to display the primary tank volume: <ul style="list-style-type: none"> <li>• <b>Gallons</b> (Default)</li> <li>• <b>Liters</b></li> </ul>
Length Units	Select the unit used to specify tank dimensions: <ul style="list-style-type: none"> <li>• <b>in</b> (Default)</li> <li>• <b>cm</b></li> <li>• <b>mm</b></li> </ul>
Diameter (D)	Enter the primary tank diameter: <ul style="list-style-type: none"> <li>• 0.0–999.9</li> </ul>
Full Height (F)	Enter the fluid height from the bottom of the tank to the maximum level that will indicate 100% on the level sensor: <ul style="list-style-type: none"> <li>• 0.0–999.9</li> </ul>
Empty Height (E)	Specify the fluid height from the bottom of the tank to the minimum level that will indicate 0% on the level sensor: <ul style="list-style-type: none"> <li>• 0.0–999.9</li> </ul>



## Set Up Secondary Tanks

Every Secondary Tank must be individually configured.

Use this procedure to specify the Secondary Tank installed in one specific station. If the system contains multiple stations, use this procedure separately for the drum in each station.



Figure 72 Secondary Tank Screen

1. Press  on any Run screen to enter the Setup menu screen.
2. Press **Secondary Tank**.
3. On the Secondary Tank screen, press the **Station Number** field.
4. On the **Station Number** keypad, enter the number of the station to be configured.

The number in the field is the station that is being configured. The station name is displayed directly below the Station Number.

5. Press each item's data field and use the keypad that displays to specify the equipment used in the selected station. For a list of fields, see [Fields on the Secondary Tank Setup Screen](#).

**NOTE:** For a newly-created station, all fields read **No** or **None**.

6. Repeat steps 3–6 for each additional station in the system.

**Table 10 Fields on the Secondary Tank Setup Screen**

Item	Description
Station Number	The current station number being displayed: <ul style="list-style-type: none"> <li>• 1–Maximum number of stations</li> </ul>
Station Name	The alphanumeric name of the current station being displayed: <ul style="list-style-type: none"> <li>• 0–20 characters</li> </ul>
Secondary Tank	Select <b>Yes</b> if the selected station has a Primary Tank. Select <b>No</b> if there is no Primary Tank installed.
Agitator Type	Select the type of agitator installed on the Secondary Tank: <ul style="list-style-type: none"> <li>• <b>None</b> (Default)</li> <li>• <b>60 Hz Direct Drive</b> (Maximum frequency of 18 Hz)</li> <li>• <b>60 Hz Back Gear</b> (Maximum frequency of 43 Hz)</li> <li>• <b>50 Hz Direct Drive</b> (Maximum frequency of 18 Hz)</li> <li>• <b>50 Hz Back Gear</b> (Maximum frequency of 43 Hz)</li> <li>• <b>60 Hz Custom</b> (Maximum frequency of 60 Hz)</li> <li>• <b>50 Hz Custom</b> (Maximum frequency of 50 Hz)</li> </ul> For part numbers, see <a href="#">Appendix F: Agitator Part Numbers, page 163</a> . <b>NOTE:</b> When an Agitator Type is configured, the “Agitator” button appears. Use this button to navigate to the Secondary Tank Agitator setup.
Level Sensor Type	Select the type of level sensor installed on this Secondary Tank: <ul style="list-style-type: none"> <li>• <b>None</b> (Default)</li> <li>• <b>Radar</b></li> </ul> <b>NOTE:</b> When a Level Sensor Type is configured, the “Volume Configuration” button appears. Use this button to navigate to the Secondary Tank Volume Configuration setup.
Level Sensor Location	Select the level sensor: <ul style="list-style-type: none"> <li>• <b>None</b></li> <li>• <b>Tank Control</b></li> <li>• <b>Lenze</b></li> </ul>
Actual Level	Displays the current fluid level in the Secondary Tank. (Read Only)
Low Level Deviation	Enter a number to specify the tank level (0-100%) at which a Tank Level Low deviation is generated. <b>NOTE:</b> 0% disables the low tank deviation.
Low Level Alarm	Enter a number to specify the tank level (0-100%) at which a Tank Level Low alarm is generated. <b>NOTE:</b> 0% disables the low tank deviation.

## Set Up Secondary Agitator



Figure 73 Secondary Agitator Screen

1. Press  on any Run screen to enter the Setup menu screen.
2. Press **Secondary Agitator**.
3. On the Secondary Agitator screen, press the **Station Number** field.
4. On the **Station Number** keypad, enter the number of the station to be configured.

The number in the field is the station that is being configured. The station name is displayed directly below the Station Number.

5. Press each item's data field and use the keypad that displays to specify the equipment used in the selected station. For a list of fields, see [Fields on the Secondary Agitator Setup Screen](#).

NOTE: For a newly-created station, all fields read **No** or **None**.

6. Repeat steps 3–6 for each additional station in the system.

**Table 11 Fields on the Secondary Agitator Setup Screen**

Item	Description
Station Number	The current station number being displayed: <ul style="list-style-type: none"> <li>• 1–Maximum number of stations</li> </ul>
Station Name	The alphanumeric name of the current station being displayed: <ul style="list-style-type: none"> <li>• 0–20 characters</li> </ul>
Variable Frequency Drive	Select the manufacturer of the Variable Frequency Drive/Inverter used to control the agitator in the Secondary Tank: <ul style="list-style-type: none"> <li>• <b>None</b> (Default)</li> <li>• <b>Lenze</b> (Lenze SMVector)</li> <li>• <b>AB PowerFlex 4M</b> (Allen Bradley PowerFlex 4M)</li> <li>• <b>AB PowerFlex 525</b> (Allen Bradley PowerFlex 525)</li> <li>• <b>Mitsubishi</b> (FR-F800 and FR-E700 series)</li> </ul> For Lenze part numbers, see <a href="#">Variable Frequency Drive/Inverter (B) 17N041, 17N042, 17N043, page 17</a> .
Agitator Profile	Select <b>Enable</b> to allow the secondary tank agitator to be controlled by agitator profiles. Select <b>Disable</b> to disable agitator profiles. See <a href="#">Set Up Agitator Profile, page 89</a> , for more information about setting up agitator profiles.
Production Enable	Select <b>Enable</b> to enable the following features: <ul style="list-style-type: none"> <li>• When the system goes into production, it will monitor agitator status and trigger event if the agitator is idle for xx amount of time. (See the Idle Timer field below.)</li> <li>• If Agitator Profile is enabled, the agitator will automatically be pushed into profile 1 when in production, and profile 2 when not in production.</li> </ul> Select <b>Disable</b> to disable tracking of agitator status and scheduled control of profiles.
Idle Timer	Enter the number of minutes the agitator has not been running before a Secondary Agitator Stopped (H1B0) event is triggered. Production Enable for this station has to be enabled for an event to trigger. <ul style="list-style-type: none"> <li>• 0–999 minutes</li> </ul> <p><b>NOTE:</b> When Idle Timer is set to 0, systems will not monitor agitator status while in production.</p>

## Configure Secondary Tank Volume



Figure 74 Secondary Tank Configuration Screen

1. Press  on any Run screen to enter the Setup menu screen.
2. Press **Secondary Agitator**.
3. On the Primary Agitator screen, press the **Station Number** field.
4. On the **Station Number** keypad, enter the number of the station to be configured.

The number in the field is the station that is being configured. The station name is displayed directly below the Station Number.

5. Press each item's data field and use the keypad that displays to specify the equipment used in the selected station. For a list of fields, see .

**NOTE:** For a newly-created station, all fields read **No** or **None**.

6. Repeat steps 3–6 for each additional station in the system.

**Table 12 Fields on the Secondary Tank Configuration Screen**

Item	Description
Station Number	The current station number being displayed: <ul style="list-style-type: none"> <li>• 1–Maximum number of stations</li> </ul>
Station Name	The alphanumeric name of the current station being displayed: <ul style="list-style-type: none"> <li>• 0–20 characters</li> </ul>
Tank Type	Select the secondary tank type: <ul style="list-style-type: none"> <li>• <b>Unknown</b> (Default)</li> <li>• <b>Cylinder</b></li> </ul>
Volume Units	Select the unit to display the secondary tank volume: <ul style="list-style-type: none"> <li>• <b>Gallons</b> (Default)</li> <li>• <b>Liters</b></li> </ul>
Length Units	Select the unit used to specify tank dimensions: <ul style="list-style-type: none"> <li>• <b>in</b> (Default)</li> <li>• <b>cm</b></li> <li>• <b>mm</b></li> </ul>
Diameter (D)	Enter the secondary tank diameter: <ul style="list-style-type: none"> <li>• 0.0–999.9</li> </ul>
Full Height (F)	Enter the fluid height from the bottom of the tank to the maximum level that will indicate 100% on the level sensor: <ul style="list-style-type: none"> <li>• 0.0–999.9</li> </ul>
Empty Height (E)	Enter the fluid height from the bottom of the tank to the minimum level that will indicate 0% on the level sensor: <ul style="list-style-type: none"> <li>• 0.0–999.9</li> </ul>

## Create Pump Profiles

Every pump installed in a station is used to constantly circulate fluid through the paint kitchen. The pump speed or output pressure varies, depending on the conditions within the system or the current operational status of the station.

For example, one profile might be set up and used when the paint system is in production mode, where high flow rate or pressure is needed to accommodate one or more paint sprayers. A second profile might be created for use when the paint system is in non-production mode, where a low flow rate or pressure is needed to circulate paint through the system.

Use this procedure to create up to four profiles for each pump. Each profile determines how a pump performs under a set of specified conditions.

1. Press  on any Run screen to enter the Setup menu screen.
2. Press **Profiles**.
3. On the Profiles screen, press **Pump**.

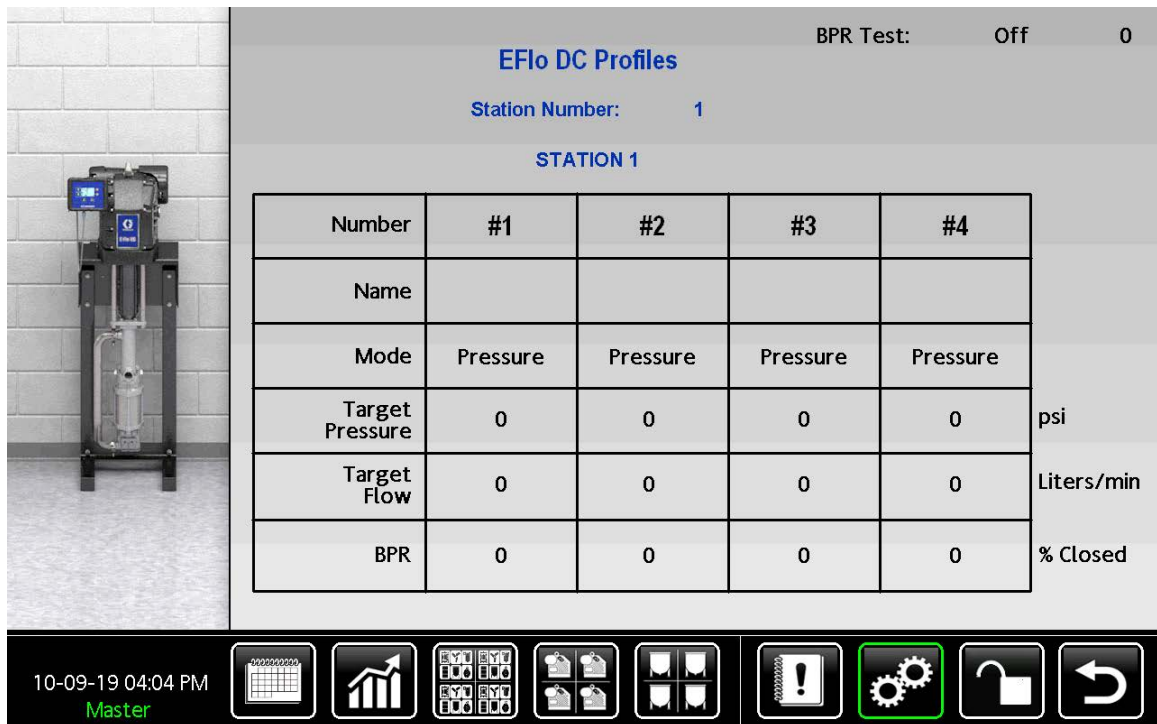

BPR Test: Off 0

### EFlo DC Profiles

Station Number: 1

#### STATION 1

Number	#1	#2	#3	#4	
Name					
Mode	Pressure	Pressure	Pressure	Pressure	
Target Pressure	0	0	0	0	psi
Target Flow	0	0	0	0	Liters/min
BPR	0	0	0	0	% Closed

10-09-19 04:04 PM  
Master

Figure 75 Profiles Screen

4. On the E-Flo DC Profiles screen, press the **Station Number** field.

5. On the **Station Number** keypad, enter the number of the station to be configured.

The number in the field is the station that is being configured. The station name is displayed directly below the station number.

*Using the Setup Screens*

6. Set up a profile for the pump located in the selected station.

Each column (#1, #2, #3, and #4) in the table contains the parameters for one profile. Press each item's data field and use the keypad that displays to create each pump profile.

Item	Description
Station Number	The current station number being displayed: <ul style="list-style-type: none"> <li>• 1–Maximum number of stations</li> </ul>
Station Name	The alphanumeric name of the current station being displayed: <ul style="list-style-type: none"> <li>• 0–20 characters</li> </ul>
Number	The number for each pump profile displayed: <ul style="list-style-type: none"> <li>• 1–4 profiles</li> </ul>
Name	The alphanumeric name for each pump profile displayed: <ul style="list-style-type: none"> <li>• 0–20 characters</li> </ul>
Mode	Use the keypad to select the method used to determine when this profile is used: <ul style="list-style-type: none"> <li>• <b>Flow:</b> The Intelligent Paint Kitchen uses flow output from the pump to decide if this profile should be used. In flow mode, the motor maintains a constant speed to maintain the target flow rate, regardless of the fluid pressure, up to the pump's maximum working pressure.</li> <li>• <b>Pressure:</b> The Intelligent Paint Kitchen uses output pressure from the pump to decide if this profile should be used. In pressure mode, the motor adjusts the pump speed to maintain the fluid pressure percentage. If the flow limit is reached before the target pressure, the unit stops driving to the pressure (if set as an alarm).</li> </ul>
Target Pressure	Use the keypad to enter the pump output pressure to be maintained when this profile is used. Units of measure (% , X, or Y) are the Pressure Units set up for this pump. See <a href="#">Set Up E-Flo DC Pumps, page 70</a> .
Target Flow	Use the keypad to enter the output flow to be maintained by the pump when this profile is used. Units of measure (liters, gallons, cc, or oz per minute) are the Volume Units set up for this pump. See <a href="#">Set Up E-Flo DC Pumps, page 70</a> .
BPR	Use the keypad to enter the setting of the back pressure regulator when this profile is used by the pump. Unit of measure is the percent (0 to 100%) open setting of the Back Pressure Regulator.

7. Repeat step 6 to create additional profiles (up to four maximum) for the selected pump.

If you do not need a profile, leave the column for the unused profile set to 0.



## Set Up Agitator Profile



Figure 76 Primary Agitator Profile Screen



Figure 77 Secondary Agitator Profile Screen

1. Press  on any Run screen to enter the Setup menu screen.
2. Press **Secondary Agitator**.
3. On the Primary Agitator screen, press the **Station Number** field.

4. On the **Station Number** keypad, enter the number of the station to be configured.

The number in the field is the station that is being configured. The station name is displayed directly below the Station Number.

5. Press each item's data field and use the keypad that displays to specify the equipment used in the selected station. For a list of fields, see .

**NOTE:** For a newly-created station, all fields read **No** or **None**.

- Repeat steps 3–6 for each additional station in the system.



**Table 13 Fields on the Agitator Profiles Screen**

Item	Description
Station Number	The current station number being displayed: • 1–Maximum number of stations
Station Name	The alphanumeric name of the current station being displayed: • 0–20 characters
Profile Number	The current agitator profile number being displayed: • 1–2
Profile Name	The alphanumeric name of the agitator profile being displayed: • 0–10 characters <b>NOTE:</b> The system supports two profiles per agitator.
Minimum Speed	Enter the minimum speed setpoint for the agitator at the minimum tank level. • 0–100%
Minimum Level (L)	Enter the minimum tank level. • 0–100%
Maximum Speed	Enter the maximum speed set point for the agitator at the maximum tank level. • 0–100%
Maximum Level (H)	Enter the maximum tank level. • 0–100%
On Time	Enter the On time when using agitator duty cycle. The agitator will cycle between the specified On time and Off time. • 0–59 minutes
Off Time	Enter the Off time when using agitator duty cycle. The agitator will cycle between the specified On time and Off time. • 0–59 minutes

## Lock or Unlock Setup Screens

At the bottom of each Run screen, an icon indicates whether access to that screen is locked or unlocked.

If the screen is locked and you press an onscreen control to enter or change settings, the Enter Password screen appears. Enter the password to continue. See [Enter Password, page 97](#).

- Press  to lock the screen.
- Press  and enter the password to unlock the screen.

## Set Up Production Schedule

Production Schedule

Preset: 1

Time	Monday	Tuesday	Wednesday	Thursday	Friday	Saturday	Sunday
#1	▶ 02:00	▶ 03:00	▶ 04:00	▶ 05:00	▶ 06:00	⏸ 00:00	⏸ 00:00
#2	⏸ 16:00	⏸ 17:00	⏸ 18:00	⏸ 19:00	⏸ 20:00	⏸ 00:00	⏸ 00:00
#3	▶ 00:00	▶ 00:00	▶ 00:00	▶ 00:00	▶ 00:00	⏸ 00:00	⏸ 00:00
#4	⏸ 00:00	⏸ 00:00	⏸ 00:00	⏸ 00:00	⏸ 00:00	⏸ 00:00	⏸ 00:00
#5	▶ 00:00	▶ 00:00	▶ 00:00	▶ 00:00	▶ 00:00	⏸ 00:00	⏸ 00:00
#6	⏸ 00:00	⏸ 00:00	⏸ 00:00	⏸ 00:00	⏸ 00:00	⏸ 00:00	⏸ 00:00

09-26-19 01:34 PM  
Master

Figure 78 Production Schedule Setup Screen

Ref.	Item	Description
1	Preset	Production schedule preset: <ul style="list-style-type: none"> <li>• 1–3</li> </ul>
2	Time	Each day offers up to 6 different times to toggle between production and off production: <ul style="list-style-type: none"> <li>• 00:00 – 23:59</li> </ul>
3	Day of Week	Day of the week to be configured: <ul style="list-style-type: none"> <li>• Monday – Sunday</li> </ul>
4	Production/Off-Production	<ul style="list-style-type: none"> <li>• ▶ - Production</li> <li>• ⏸ - Off Production</li> </ul>

## Set Up Notifications

When an alarm or event occurs, email notifications can be automatically sent by email or text message. Use this procedure to enter up to ten email addresses for up to ten users.

1. Press  on any Run screen.
2. On the Setup Menu screen, press **Email**.
3. On the Email Setup screen, press **Users**.

4. On the Email Address screen, press the data field for each column, then use the popup keypad to enter information for each person to receive Intelligent Paint Kitchen system notifications.

**NOTE:** Press Shift to type capital letters. The Shift key changes into a More key, which you can press to view and type special characters (for example @ or \_ symbols) that might be used in an email address.

Email Address				
#	User Name	Email Address	Event Type	Format
1			All Events	Email
2			All Events	Email
3			All Events	Email
4			All Events	Email
5			All Events	Email
6			All Events	Email
7			All Events	Email
8			All Events	Email
9			All Events	Email
10			All Events	Email

10-09-19 04:02 PM  
Master











Figure 79 Email Address Screen

Item	Description
User Name	Optional. Enter a name to identify the person who receives emails or text messages.
Email Address	Enter the complete email address of the user. The address must be in a format suitable for the required transport. For example, name@domain. To send a text message using email, see <a href="#">Optional Text Message Using Email</a> .
Event Type	Select the type of event that triggers an email or text message to this user: <ul style="list-style-type: none"> <li>• All Events</li> <li>• Alarms Only: Events that contain xxxx-A at the end of the error code</li> <li>• Alarms and Deviations: Events that contain xxxx-A or xxxx-D at the end of the error code</li> <li>• Tank Events: Events that pertain to tank level error codes beginning with Lxxx</li> <li>• Communication Alarms: Events that pertain to communication error codes starting with Cxxx</li> </ul>
Format	Select the method for notifying this person: <ul style="list-style-type: none"> <li>• Email</li> <li>• Text</li> </ul>

### Optional Text Message Using Email

When connected to an SMTP server, you can send SMS text messages using the email-to-text services provided by your carrier. For example, to send a message to a phone on AT&T with the number

555-555-5555, use 5555555555@txt.att.net as the address. The table lists formats for providers in North America. If you are outside North America, contact your provider for the correct format.

Provider	Email-to-SMS Address Format
AllTel	number@text.wireless.alltel.com
AT&T	number@txt.att.net
Boost Mobile	number@myboostmobile.com
Cricket	number@sms.mycricket.com
Sprint	number@messaging.sprintpcs.com
T-Mobile	number@tmomail.net
US Cellular	number@email.uscc.net
Verizon	number@vtext.com
Virgin Mobile	number@vmobl.com

#### Sample Text Notification

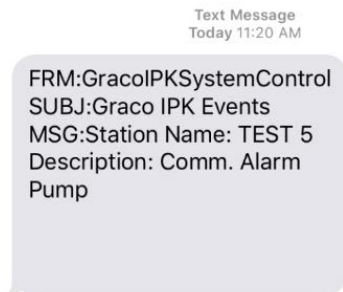

#### Sample Email Notification

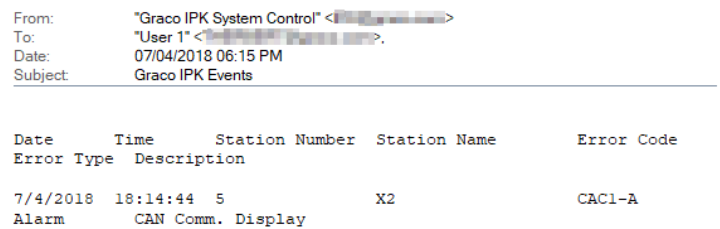

### Send a Test Email Message

Use this procedure to send a test email to an email address to verify SMTP configuration.

1. Press  on any Run screen.
2. On the Setup Menu screen, press **Email**.
3. On the Email Setup screen, press **SMTP**.
4. On the SMTP Server Configuration screen, press **Send Test Email**.
5. On the Test Email screen, press **Send Test Email**.
6. On the Test Email popup screen, press the data field to the right of **To Address:**, then use the keyboard to enter the email address or phone number of the intended recipient.

7. Press **Send Test Email** to send the email or test message to the recipient. A status message of Success or Fail appears.

If a Fail message appears, do the following:

- Verify Port 1 settings.
- Verify SMTP settings.
- Contact your IT team to verify settings.
- To troubleshoot failure using an SMTP log file stored locally on the Touchscreen SD card, follow the process in [Use a USB Drive, page 138](#) to connect by USB to the Touchscreen Module. In the root directory, open the **SMTP.log** file.

# Network Setup and Configuration

Use these procedures to configure network settings that determine how the Intelligent Paint Kitchen components communicate with each other.

## Configure the Display

Use this procedure to enter the network settings that allow the Touchscreen Module (14) to communicate with the Intelligent Paint Kitchen components.

1. Press  on any Run screen.
2. On the Setup Menu screen, press **HMI Configuration**.
3. On the Display Configuration screen, press **Port 1**. Port 1 is used to communicate with external Ethernet networks. Configure Port 1 if you want remote access or email.
4. On the read-only Network Configuration screen, press **Edit Config**.
5. On the editable Network Configuration screen, press the data fields to be changed. Use the popup screen to enter the network setting. Repeat as needed until all the Network Configuration settings are correct.

Field	Value
Port Mode	Manual or DHCP
IP Address	IP address provided by your IT team to connect to your facility network (for example, 10.20.156.34)
Subnet Mask	Subnet mask that matches your network settings
Gateway	Gateway that matches your network settings
DNS1	Your DNS1 setting
DNS2	Your DNS2 setting
MAC ID	MAC ID of your device

6. Press **Apply** to enter the changes and have them take effect . The Network Configuration screen appears again, showing the updated settings.

7. On the Display Configuration screen, press **Port 2**. Port 2 is used to communicate to the Supervisor Module using Modbus/TCP.
8. On the read-only Modbus/TCP Network Configuration screen, press **Edit Config**.

If the Modbus/TCP network has not been configured, the Modbus/TCP Network Not Configured screen displays. Press **Configure**.

9. On the editable Modbus/TCP Network Configuration screen, change the network configuration settings for Port 2.  
**NOTE:** Do not modify these settings from the default provided on this page without contacting Graco. Otherwise, the Touchscreen Module cannot control or monitor the system.

Field	Value
IP Address	192.168.1.99
Subnet Mask	255.255.255.0
Gateway	0.0.0.0
DNS1	0.0.0.0
DNS2	0.0.0.0

10. Press **Apply** to enter the changes and have them take effect .
11. Confirm that communication to the Touchscreen is working properly.

## Configure the Supervisor Module

Use this procedure to view current network status of each Supervisor Module (36) in the Intelligent Paint Kitchen system, to change the network IP configuration settings if necessary, and to confirm communication by pinging the system.

**NOTE:** Do not modify these settings unless instructed by Graco.

1. Press  on any Run screen to enter the Setup menu screen.
2. Press **Supervisor Configuration**.

On the Supervisor Configuration screen, do the following:

- Press **Status** to view the current network settings. The read-only Supervisor Status screen displays the current network settings. Each Supervisor Module in the Intelligent Paint Kitchen system is displayed as either **Online** or **Offline**.
- Press **IP Configuration** to change the IP configuration settings for the Supervisor Module.
  - a. On the read-only Supervisor Network Configuration screen, press **Edit Config**.
  - b. On the editable Supervisor Network Configuration screen, press one of the data fields to be changed. Use the popup screen to enter the network setting.

Field	Value
IP Address	192.168.1.201
Subnet Mask	255.255.255.0
Gateway	192.168.1.1



- c. Repeat as needed, until all the network configuration settings are correct.
  - d. To enter the changes and have them take effect, press **Apply**.
- Press **Baud Rate** to change the baud rate settings for the Supervisor Module. Press the **Supervisor Baud Rate** field and use the popup screen to enter the setting. The default is 57600. 38400 is also available. To enter the changes and have them take effect, press **Apply**.

Verify that the baud rate settings match the settings for the Pump Control Module and fiber optic converter. See [Set Up a Pump Control Module for Modbus Communication, page 48](#) and [Set DIP Switches on the Fiber Optic Converters, page 33](#).

3. To change the IP configuration settings, press **IP Configuration**. On the read-only Supervisor Network Configuration screen, press **Edit Config**.
4. Confirm that communication to the Supervisor Box is working properly.

## Set Up the Email Server

Use the Email Setup Screen to access the screens used to configure the SMTP server, and to enter email addresses to which notifications of Intelligent Paint Kitchen events are sent. The Intelligent Paint Kitchen must be connected to a network to send notifications to users, and Port 1 must be configured for the office network.

1. Press  on any Run screen.
2. On the Setup Menu screen, press **Email**.
3. On the Email Setup screen, press **SMTP** to set up the SMTP (Simple Mail Transfer Protocol) server.
  - To edit the current configuration settings, press **Edit Config**.
    - a. Press the data field and use the popup screens to enter each of the SMTP settings. Press Return  after you enter each setting.
      - **SMTP Server Name:** Enter the name of the SMTP server.
      - **From Address:** Enter the email address of the Intelligent Paint Kitchen unit.
      - **SMTP Port:** Enter the SMTP port. The default value is 25. Use the default value for most applications. It only needs to be adjusted if the SMTP server has been reconfigured to use another port.

- b. To enter the changes and have them take effect, press **Apply**. The SMTP Server Configuration screen appears again, showing any updated settings.
  - To send a test email, press **Send Test Email**. In the Test Email popup, press **Send Test Email**. For more information, see [Send a Test Email Message, page 93](#).
  - To check communication between the SMTP server and the Supervisor Module, on the SMTP Server Configuration screen, press **Ping**. The “Ping Status: Success” message appears if the connection is working.
4. On the Email Setup screen, press **Users** to enter contact information for users to receive email or text message notifications of Intelligent Paint Kitchen events.

Follow the procedure in [Set Up Notifications, page 92](#).

### Common Email Provider SMTP Settings







Email Provider	Setting
Gmail	<b>Server Address:</b> smtp.gmail.com <b>Username:</b> Your full Gmail address (for example, username@gmail.com) <b>Password:</b> Your Gmail password <b>Port (TLS):</b> 587 <b>Port (SSL):</b> 465 <b>TLS/SSL required:</b> Yes
Yahoo	<b>Server Address:</b> smtp.mail.yahoo.com <b>Username:</b> Your full Yahoo address (for example, username@yahoo.com) <b>Password:</b> Your Yahoo password <b>Port:</b> 465 or 587 <b>Requires SSL:</b> Yes <b>Requires TLS:</b> Yes (if available)
Outlook.com	<b>Server Address:</b> smtp-mail.outlook.com <b>Username:</b> Your full Outlook.com address (for example, username@outlook.com) <b>Password:</b> Your Outlook.com password <b>Port:</b> 587 <b>Requires STARTTLS:</b> Yes



## Create a Password

Create a numeric password when you want to limit the ability to change Intelligent Paint Kitchen settings.





If a password has been created, you are prompted to enter that password at the following times:

- When you press the setup  icon.
  - When you press an onscreen control to enter or change Intelligent Paint Kitchen software settings.
  - When you press the lock  or the unlock  icon.
1. Press  on any Run screen to enter the Setup menu screen.
  2. Press **Password**.
  3. On the Password screen, press the **Enter Password** field .
  4. On the Password popup screen, enter the password of your choice (000000 to 999999), then press Return .

**NOTE:** Question marks (??????) display in the **Password** field as you press the number keys. Make sure you know the password before you press Return.

## Change or Disable the Password

If a password is enabled for the Intelligent Paint Kitchen software, any user who knows the current password can change or disable (remove) that password.

1. Press  on any Run screen.
2. On the Enter Password screen, press  and log in using the current password.
3. On the Setup Menu screen, press **Password**.
4. On the Password screen, press the **Enter Password** field .
5. On the Password popup screen, enter a new password or disable the current password.
  - To enter a new password, enter the password (000000 to 999999), then press Return .
  - To disable the current password, press **0**, and then press Return .

**NOTE:** A password of 0 disables the password function. If the function is disabled, no password is required to access any Intelligent Paint Kitchen screen or to change any Intelligent Paint Kitchen software settings.

## Enter Password

The Enter Password screen appears when the system requires a password before you can change settings.

1. Press the **Enter Password** field .
2. On the Enter Password popup screen, enter the password (000000 to 999999), then press **OK**.

The Setup Menu screen opens, allowing access to the other Setup screens.

NOTES:

- Entering an incorrect password clears the field. Re-enter the correct password.
- To assign a password, see [Lock or Unlock Setup Screens, page 90](#).

## Security Levels

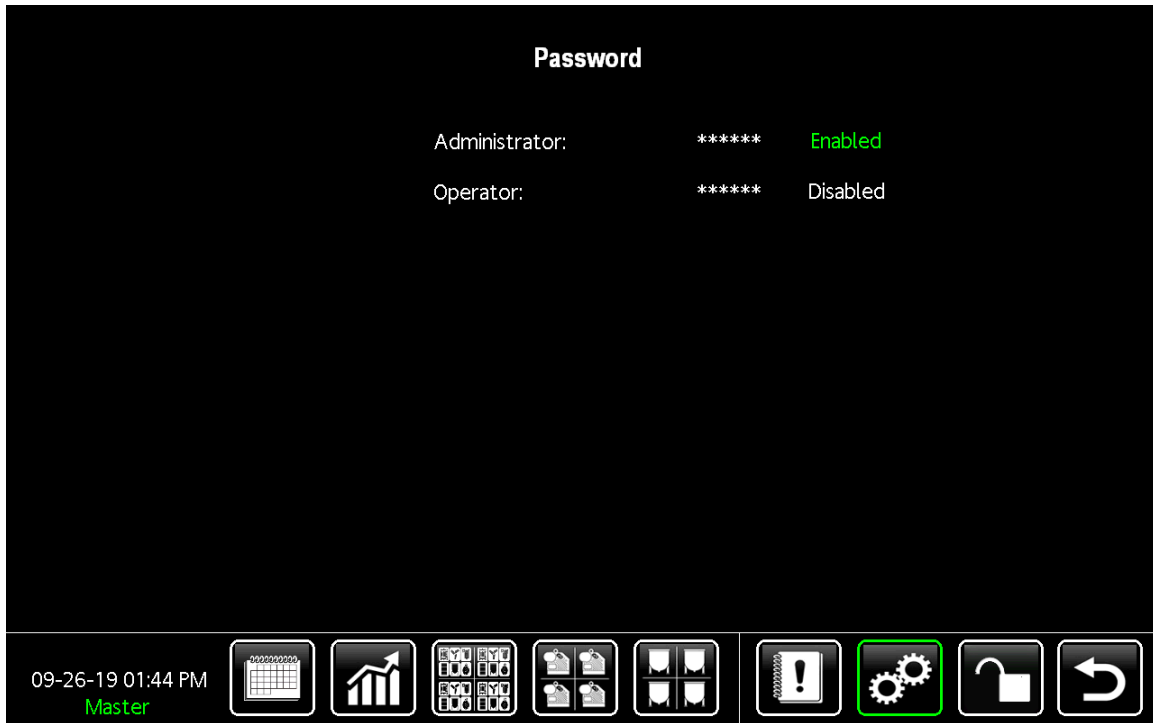

There are two levels of Administrator access:





- **Administrator:** Right to access and change all values
- **Operator:** Right to change E-Flo DC active profile

Figure 80 Security Levels Screen

# Operation

## Using the Run Screens

While the Intelligent Paint Kitchen is operating, use the top-level Run screens to control the system and view current operating conditions in each station. Access the Run screens by pressing the icon on the bottom of the Touchscreen interface.

	See <a href="#">Manage Production Schedule</a> , page 100.
	See <a href="#">View the Graphs Screen</a> , page 102.
	See <a href="#">View the Stations Screen</a> , page 104.
	See <a href="#">View the Pumps Screen</a> , page 118.
	See <a href="#">View the Tanks Screen</a> , page 120.

### Manage Production Schedule

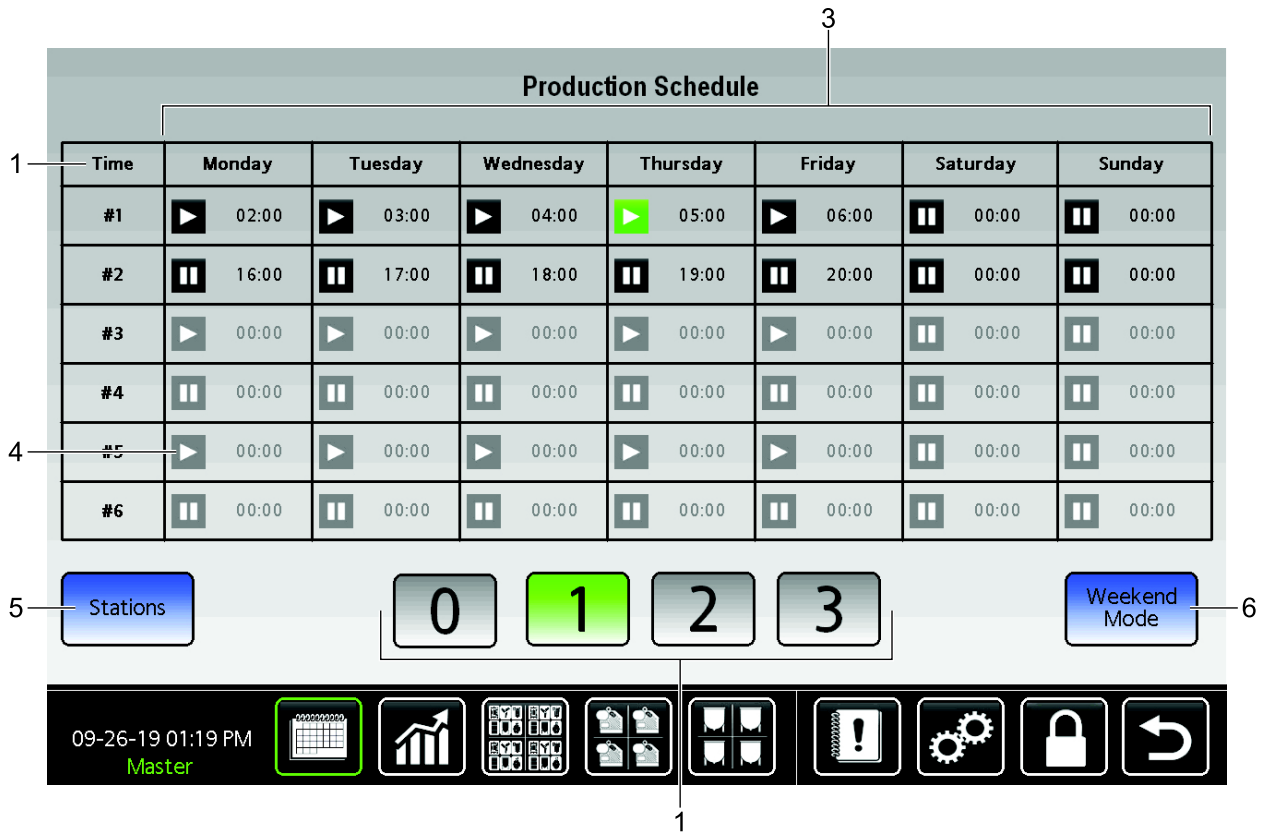





Figure 81 Production Schedule Setup Screen

Ref.	Item	Description
1	Preset	Current roduction schedule preset: <ul style="list-style-type: none"> <li>• 1-3</li> </ul>
2	Time	Each day offers up to 6 different times to toggle between production and off production: <ul style="list-style-type: none"> <li>• 00:00 – 23:59</li> </ul>
3	Day of Week	Day of the week to be configured: <ul style="list-style-type: none"> <li>• Monday – Sunday</li> </ul>
4	Current Production/Off-Production	<ul style="list-style-type: none"> <li>•  - Production</li> <li>•  - Off Production</li> </ul>

Ref.	Item	Description
5	Stations	<p>Allows grouping of stations that will be controlled by the production schedule.</p> 
6	Weekend Mode	Sets all current preset Saturday and Sunday times to off production.

## View the Graphs Screen

Use the graphs screen to display live or historical data for a selected component in a station or conditions in the station.

Use this procedure to first select the graph type, and then to view that graph for any station in the system.

The graph displays up to 48 hours of data. To obtain data up to the last seven days, use a USB to download the data.

1. Press  on any Run screen.
2. Press a button on the Graph Menu screen to select a graph for viewing.

Button	Description	Update Rate	Units
Flow Rate	Displays data on the flow rate of fluid through the pump in the selected station.	5 seconds	<ul style="list-style-type: none"> <li>• Liters/min</li> <li>• Gallons/min</li> <li>• cc/min</li> <li>• oz/min</li> <li>• Cycles/min</li> </ul>
Pump Speed	Displays data on actual operating speed of the pump in the selected station.	5 seconds	Cycles per minute
Transducer 1	Displays data obtained from pressure sensor #1 on the pump, if the sensor is installed.	5 seconds	<ul style="list-style-type: none"> <li>• psi</li> <li>• Bar</li> <li>• MPa</li> </ul>
Transducer 2	Displays data obtained from pressure sensor #2 on the pump, if the sensor is installed.	5 seconds	<ul style="list-style-type: none"> <li>• psi</li> <li>• Bar</li> <li>• MPa</li> </ul>
Pump Force	Displays data on the pressure generated by the pump in the selected station.	5 seconds	Percent
Primary Tank Level	Displays fluid level data for the Primary Tank.	60 seconds	Percent
Primary Agitator	Displays agitator speed for the agitator installed in the Primary Tank.	5 seconds	<ul style="list-style-type: none"> <li>• %</li> <li>• Hz</li> <li>• RPM</li> </ul>
Secondary Tank Level	Displays fluid level data in the Secondary Tank.	60 seconds	Percent
Secondary Agitator	Displays agitator speed for the agitator installed in the fluid supply.	5 seconds	<ul style="list-style-type: none"> <li>• %</li> <li>• Hz</li> <li>• RPM</li> </ul>

3. Use the controls on the graph to change the view or type of data displayed.

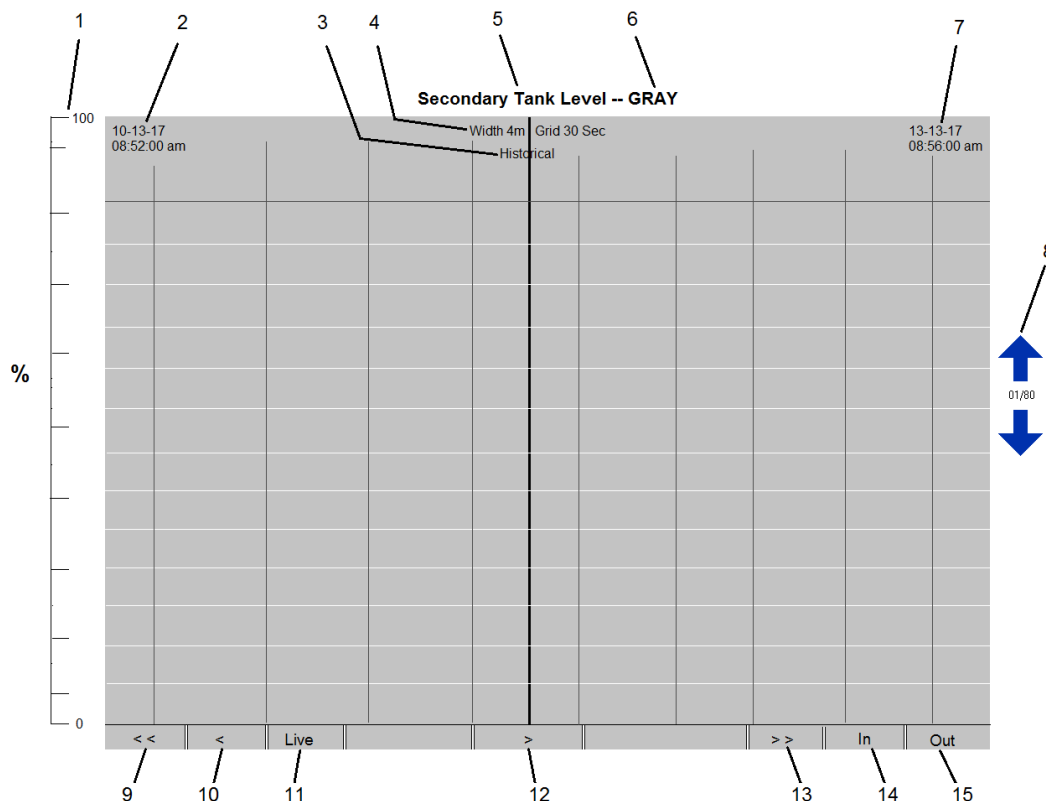

Figure 82 Example: Graph Screen

4. When finished, press  to return to the Graph Menu screen.

Item	Description
1	Shows the percent, pressure, or speed of the parameter being measured, e.g., tank level. Units of measure depends on the graph type.
2	Shows the date and time that data on the left edge of the screen was obtained.
3	Indicates whether the displayed data is <b>Live</b> or <b>Historical</b> .
4	Indicates the definition of the displayed column width: distance and time frame.
5	Shows the name of the displayed graph. Corresponds with the button pressed on the Graph Menu screen.
6	Shows the name of the currently selected station.
7	Shows the date and time that data on the right edge of the screen was obtained.
8	If the Intelligent Paint Kitchen controls multiple stations, press the up or down arrow to display the current graph for a different station.
9	Press << to scroll one screen to the left and view older data.
10	Press < to scroll slightly to the left and view older data.
11	Toggles between <b>Live</b> and <b>Historical</b> . Press to change the graph view. In the <b>Live</b> view, screen data scrolls to the left as time elapses.
12	Press > to scroll slightly to the right and view newer data.
13	Press >> to scroll one screen to the right and view newer data.
14	Press <b>In</b> to zoom in and view a detailed portion of the graph.
15	Press <b>Out</b> to zoom out and view a wider graph area.

### View the Stations Screen













The Stations screen displays component-level information for every component in the station. From this screen, you can quickly evaluate the status of your fluid. You can navigate directly to detail screens for any station, pump, tank, drum, or agitator in the system.



Press  on any Run screen to display the Stations screen. Each row of controls represents one station that has been created and configured through the Intelligent Paint Kitchen software.

Each control icon displayed in a row indicates a component that is physically installed in the station and has been configured to communicate with the Intelligent Paint Kitchen software. See [Configure Each Station, page 66](#).

Any space that is empty (does not contain an icon) indicates a component that is not installed in the station. For example, station 2 (TEST2) has two agitators installed: one in the Primary Tank, and one in the Secondary Tank. However, station 3 (TEST3) has no agitators installed.

Production #	Station Name	Pump	Primary	Agitator-1	Secondary	Agitator-2
 01	STATION 1					
 02	STATION 2					
 03	STATION 3					
 04	STATION 4					
 05	STATION 5					
 06	STATION 6					
 07	STATION 7					







10-09-19 03:42 PM  
Master



Figure 83 Stations Screen



You can perform any of the following tasks from the Stations screen:

Task	Action
Enable production on a station	<p>In the <b>Production</b> column for the station, press <b>Off</b>. The button changes to <b>On</b> and turns green to indicate that the station is successfully enabled.</p> <p>If the agitator idle time is set to 0, this feature is disabled.</p> <p>When production is enabled, the system generates an event in the following cases:</p> <ul style="list-style-type: none"> <li>• The pump transitions from the <b>On</b> to <b>Off</b> state.</li> <li>• The agitator transitions from the <b>On</b> to <b>Off</b> state.</li> </ul>
Disable a station	<p>In the <b>Production</b> column for the station, press <b>On</b>. The button changes to <b>Off</b> and turns blue to indicate that the station is disabled.</p>
View the Station Status screen for a station	<p>Press the <b>Station</b> button for the station. See <a href="#">Station Status Screen, page 106</a>.</p>
View the Pump Status screen for a station	<p>In the <b>Pump</b> column for the station, press the pump icon . See <a href="#">Pump Status Screen, page 109</a>.</p>
View the Primary Tank Status screen for a station	<p>In the <b>Primary</b> column for the station, press the tank icon . See <a href="#">Primary Tank Status Screen, page 111</a>.</p>
View the Secondary Tank Status screen for a station	<p>In the <b>Secondary</b> column for the station, press the tank icon . See <a href="#">Secondary Tank Status Screen, page 113</a>.</p>
View the Agitator Status screen for a station	<p>In an <b>Agitator</b> column for the station, press the agitator icon . See <a href="#">Agitator Run Screen, page 114</a>.</p>

### Station Status Screen

The Station Status screen is a visual representation of the components that are physically installed in a station. Access this screen from the Stations screen (see [View the Stations Screen, page 104](#)).



Only those components that have been created and configured using the Intelligent Paint Kitchen software are displayed on the screen. If you switch from one station to another, the displayed components may change, depending on each station's configuration.

Use this screen to view detailed operating conditions in the selected station and its components. Some component settings can be changed from this screen, as described in the table below. You can also navigate directly from this screen to the Pump Status screen, the Primary Tank Status screen, the Secondary Tank Status screen, and the Agitator Status screens, for any components present in the selected station.



Figure 84 Station Status Screen

Ref.	Item	Description
1	Station Number	Displays the number of the station for which information is displayed. Press to display a keypad and select a different station to view.
2	Secondary Agitator Speed	Displays the operating speed (in RPM, Hz, or %) of a secondary electric agitator installed in the Secondary Tank. Press to display a keypad and change the agitator speed.
3	Station Name	Displays the name of the currently selected station.
4	Enable Secondary Agitator	Press the image of a Secondary Tank to display the Secondary Agitator Enable popup screen. Use the popup to enable or disable the selected agitator.  If the agitator is operating, its blades are shown in motion on this screen.

Ref.	Item	Description
5	Pneumatic Remote Transfer Fill Pump Status	Indicates the current status of the pump.  indicates that the pump is stopped.  indicates that the pump is transferring fluid to the Primary Tank.
6	Back Pressure Regulator Status	Displays the current Back Pressure Regulator setting in %. Press to display a keypad and change the Back Pressure Regulator setting.
7	Primary Agitator Status	Displays the operating speed (in RPM, Hz, or %) of the primary electric agitator installed in the circulation. Press to display a keypad and change the agitator speed.
8	Enable Primary Agitator	Press the image of a Primary Tank to display the Primary Agitator Enable popup screen. Use the popup to enable or disable the selected agitator. If the agitator is operating, its blades are shown in motion on this screen.
—	Secondary Agitator Status	Displays the operating speed (in RPM, Hz, or %) of the secondary electric agitator installed in the circulation. Press to display a keypad and change the agitator speed.
—	Enable Secondary Agitator	Press the image of a Secondary Tank to display the Secondary Agitator Enable popup screen. Use the popup to enable or disable the selected agitator. If the agitator is operating, its blades are shown in motion on this screen.
9	Tank Status	Read only. Displays the level of fluid in the Primary Tank.
10	Select Pump Profile	Press the image of the pump to display the Profile Select popup screen. Use the popup to enable or disable a profile for the selected pump.
11	E-Flo DC Pump Status	Read only. Displays current operating conditions in the pump: <ul style="list-style-type: none"> <li>• Profile: Displays the profile (0–4) that is controlling the pump’s operation.</li> <li>• Mode: Off, Flow, or Pressure (If Off, the Profile is 0.)</li> <li>• Cycles/min: Current speed of the pump in cycles per minute.</li> <li>• Force: Current force that the pump is currently provided in a range of 0—100%</li> <li>• Flow Rate: Indicates the pump’s current flow rate in cycles/min, oz/min, cc/min, Gallons/min, or Liters/min, as chosen when the pump was set up.</li> <li>• Current Pressure for pressure transducer 1: Port 7 Pump Control Module</li> <li>• Current Pressure for pressure transducer 2: Port 10 Pump Control Module</li> </ul>
12	Pump Size	Read-only. Displays the configured pump size for that station on the Pump Control Module: 220 cc, 290 cc, 750 cc, 1000 cc, 1500 cc, 2000 cc, 3000 cc, 4000 cc See <a href="#">Set Up E-Flo DC Pumps, page 70</a> to change this setting if a different size pump is installed.
13	Arrow	Closed loop pressure has been assigned to that pressure transducer. Press  to view or change the pump output pressure. For more information, see Setup Screens 8 and 9 in the E-Flo DC Control Module Kit manual 3A2527.

Operation

Ref.	Item	Description
14	Pump icon	Press to display the Pump Status screen. The color of the icon indicates the status of the agitator.
15	Primary tank icon	Press to display the Primary Tank Status screen. The color of the icon indicates the status of the tank.
16	Primary agitator icon	Press to display the Primary Agitator Status screen. The color of the icon indicates the status of the agitator.
17	Secondary tank icon	Press to display the Secondary Tank Status screen. The color of the icon indicates the status of the tank.
18	Secondary agitator icon	Press to display the Secondary Agitator Status screen. The color of the icon indicates the status of the agitator.

Pump agitator icons:

- Green: Running
- Yellow: Running with deviations
- Red: Stopped with alarm

Tank icons:

- Green: Tank level is within the high and low alarm
- Yellow: Tank level is between the fill level and the low level alarm
- Red: Tank level is above high level or below low level

## Pump Status Screen

The Pump Status screen displays live operational data for the pump installed in the selected station.

Use this screen to view detailed and current information for the primary pump in any station.

Access this screen from the Stations screen (see [View the Stations Screen, page 104](#)).

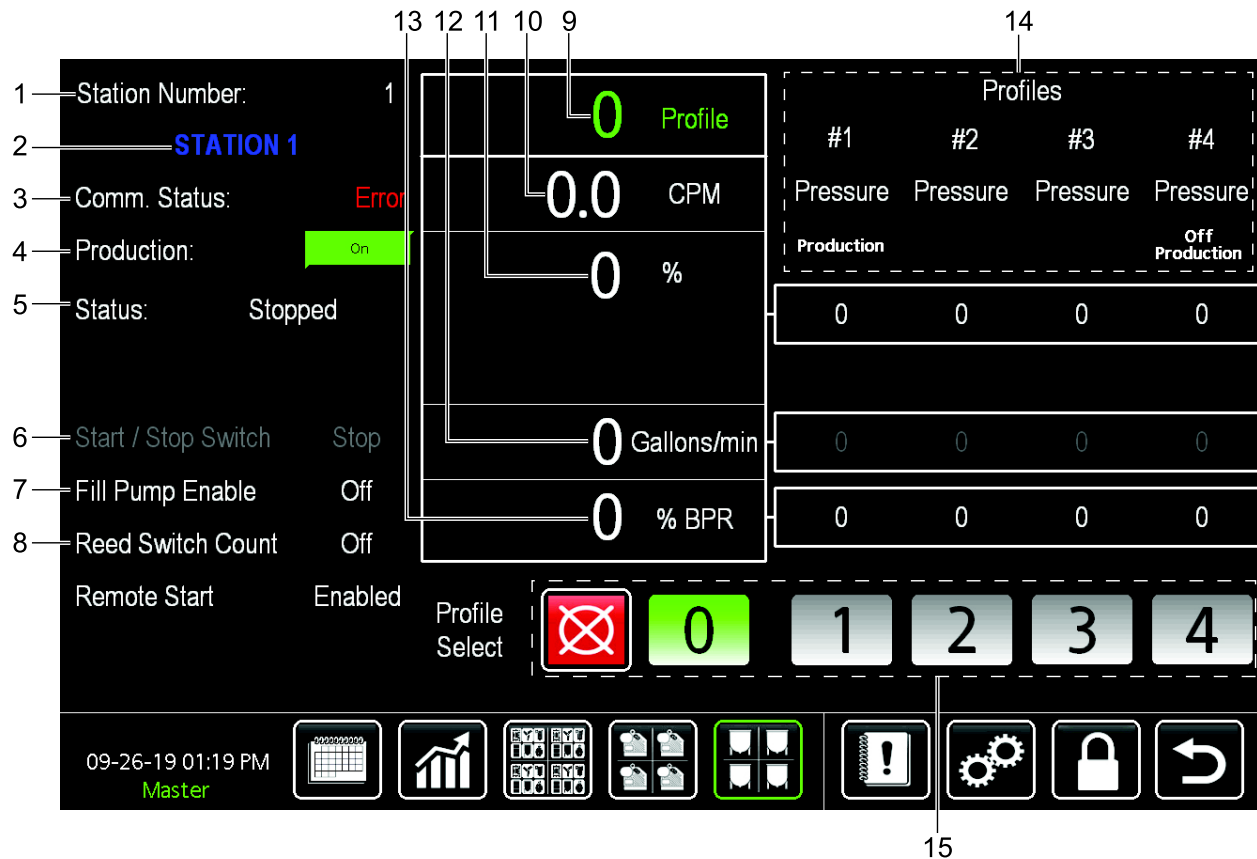









Figure 85 Pump Status Screen

Ref.	Item	Description
1	Station Number	Displays the number of the station. Press to display a keypad and select a different station to view.
2	Station Name	Displays the name of the currently selected station.
3	Comm. Status	Indicates the communication status between the pump and the Intelligent Paint Kitchen software: <ul style="list-style-type: none"> <li>• OK</li> <li>• Error</li> </ul>
4	Production	Press this button to turn Production on or off for the currently selected pump.

Ref.	Item	Description
5	Status	<p>Indicates whether the pump is stopped, stalled, or running.</p> <ul style="list-style-type: none"> <li>• Stopped</li> <li>• Stalled</li> <li>• Running</li> <li>• Stopped — Deviation</li> <li>• Stalled — Deviation</li> <li>• Running — Deviation</li> <li>• Stopped — Alarm</li> <li>• Stopped — Advisory</li> <li>• Stalled — Advisory</li> <li>• Running — Advisory</li> </ul>
6	Run/Stop Switch	Indicates whether the run/stop switch for the pump is on or off.
7	Fill Pump Enable	Indicates whether the remote transfer fill pump in this station is on (pumping), or off (not pumping).
8	Reed Switch Count	Auxiliary function. Indicates the cycle count.
9	Active Profile	Displays the profile (if one is selected) that is currently specifying pump performance.
10	CPM	Real time display of the pump operating speed in cycles per minute.
11	Pressure	<p>Real time display of the pump output pressure. Displayed in the units of measure chosen when the pump was set up.</p> <p>Press  to view or change the pump output pressure.</p>
12	Flow	Real time display of the pump flow rate. Displayed in the units of measure chosen when the pump was set up.
13	% BPR	<p>Real time display of the Back Pressure Regulator setting.</p> <ul style="list-style-type: none"> <li>• 0% = Open</li> <li>• 100% = Closed</li> </ul>
14	Profiles	Each column (#1–#4) displays the settings of a pump profile. When one of these profiles is selected, the chosen column is highlighted in green.
15	Profile Select	<p>Press one of the following to choose the profile and set operation parameters for the pump:</p> <p> Turn off the pump.</p> <p> Turn off the pump.</p> <p> Select Profile 1, if created.</p> <p> Select Profile 2, if created.</p> <p> Select Profile 3, if created.</p> <p> Select Profile 4, if created.</p>

## Primary Tank Status Screen

The Primary Tank Status screen displays live operational data for the Primary Tank installed in the selected station.

Use this screen to view current status and to view or change level settings for the Primary Tank in the selected station.

Press  to access this screen from the Stations screen. See [View the Stations Screen, page 104](#).



Figure 86 Primary Tank Status Screen

Item	Description
Primary Tank	Indicates that the information on this screen is for the Primary Tank installed in the selected station.
Station Number	Displays the number of the station for which information is displayed. Press to display a keypad and select a different station to view.
Station Name	Displays the name of the currently selected station. For example, TEST 1.
Status	
Actual Level	Read only. Displays the current fluid level in the Primary Tank.
Freeze Level	
High Level Alarm (HL)	Press to display a keypad used to set the fluid level (0–100%) at which a Primary Tank High alarm is triggered. The Primary Tank High alarm cannot be lower than the Primary Tank Low alarm.
Low Level Alarm (LL)	Press to display a keypad used to set the fluid level (0–100%) at which a Primary Tank Low alarm is triggered. The Primary Tank Low alarm cannot be higher than the Primary Tank High alarm.

*Operation*

<b>Item</b>	<b>Description</b>
Target Level (TL)	Press to display a keypad used to specify the fluid level in the tank. This level (0–100%) must be in-between the high level alarm setting and the low level alarm setting
Fill Level (FL)	Press to display a keypad used to specify the tank fill percentage that turns on the remote transfer pump.



## Secondary Tank Status Screen

The Secondary Tank Status screen displays live operational data for the Secondary Tank installed in the selected station.

Use this screen to view current status and to view or change level settings for the Secondary Tank in the selected station.

Press  to access this screen from the Stations screen. See [View the Stations Screen, page 104](#).



Figure 87 Secondary Tank Status Screen

Item	Description
Secondary Tank	Indicates that the information on this screen is for the Secondary Tank installed in the selected station.
Station Number	Displays the number of the station for which information is displayed. Press to display a keypad and select a different station to view.
Station Name	Displays the name of the currently selected station. For example, TEST1.
Actual Level	Read only. Displays the current fluid level in the Secondary Tank.
Low Level Deviation (LD)	Press to display a keypad used to set the fluid level (0–100%) at which a Secondary Tank Low Deviation is triggered.  The Secondary Tank Low Deviation cannot be lower than the Secondary Tank Low Alarm.  This event signals the user to refill or change the Secondary Tank before an alarm shuts down the system.
Low Level Alarm (LL)	Press to display a keypad used to set the fluid level (0–100%) at which a Secondary Tank Low Alarm is triggered.  The Secondary Tank Low Alarm cannot be higher than the Secondary Tank Low Deviation.

## Agitator Run Screen

Use this screen to view detailed and current information for the primary agitator in any station.

The Agitator Run screen displays live operational data for the agitator installed in the selected station.

Access this screen from the Stations screen (see [View the Stations Screen, page 104](#)).

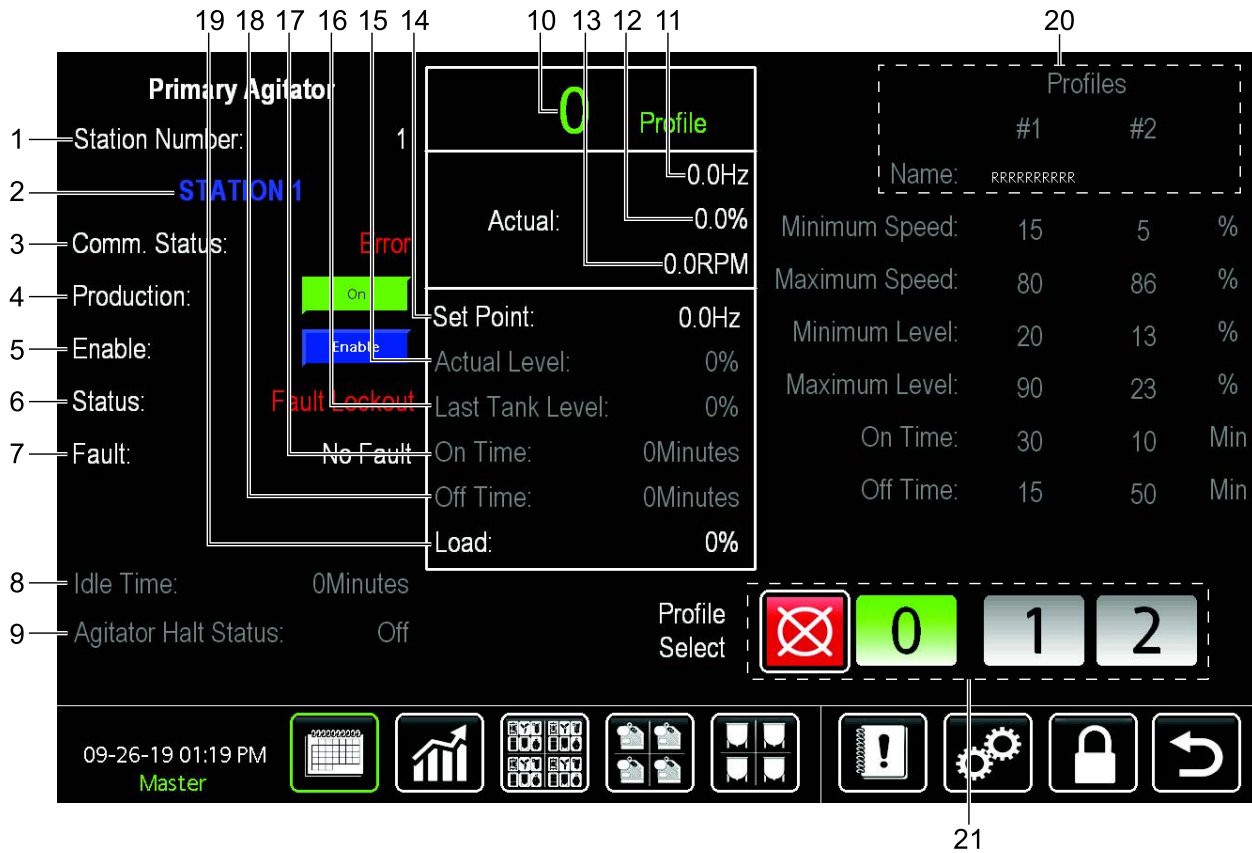





Figure 88 Primary Agitator Run Screen

Ref.	Item	Description
1	Station Number	Displays the number of the station. Press to display a keypad and select a different station to view.
2	Station Name	Displays the name of the currently selected station.
3	Comm. Status	Indicates the communication status between the variable frequency drive and the Intelligent Paint Kitchen software: <ul style="list-style-type: none"> <li>• OK</li> <li>• Error</li> </ul>
4	Production	In the Production column for the station, press Off. The button changes to On and turns green to indicate that the station is successfully enabled. <b>NOTE:</b> See “Production Enable” on <a href="#">Set Up Agitator Profile, page 89</a> .

Ref.	Item	Description
5	Enable	<p>The read-only part of the field (On or Off) indicates the current status of the Variable Frequency Drive/Inverter controlling the selected agitator.</p> <ul style="list-style-type: none"> <li>• If the Variable Frequency Drive/Inverter is Off, press Enable to start the Variable Frequency Drive/Inverter.</li> <li>• If the Variable Frequency Drive/Inverter is On, press Disable to stop the Variable Frequency Drive/Inverter.</li> </ul>
6	Status	<ul style="list-style-type: none"> <li>• Fault Lockout</li> <li>• Fault</li> <li>• Start Pending</li> <li>• IDE Not Done</li> <li>• Inhibit</li> <li>• Stop</li> <li>• Lower Transistor Switching On</li> <li>• Run IDE</li> <li>• Run</li> <li>• Accel</li> <li>• Decel</li> <li>• Decel Override</li> <li>• DC Brake</li> <li>• Flying Restart</li> <li>• Slow Current Limit</li> <li>• Fast Current Limit</li> <li>• Sleep</li> </ul>

Operation

Ref.	Item	Description
7	Fault	<ul style="list-style-type: none"> <li>• No Fault</li> <li>• TMP Output Fault</li> <li>• Output (Transistor) Fault</li> <li>• Ground Fault</li> <li>• High Drive Temperature</li> <li>• Flying Start Fault</li> <li>• High DC Bus Voltage</li> <li>• Low DC Bus Voltage</li> <li>• Thermal Overload</li> <li>• OEM Fault</li> <li>• Illegal Setup</li> <li>• Dynamic Brake Over Temperature</li> <li>• Single Phase Fault</li> <li>• External Fault</li> <li>• Control Fault</li> <li>• Start Error</li> <li>• Incompatibility Fault</li> <li>• Internal Fault 1 (EPM)</li> <li>• Internal Fault 2</li> <li>• Internal Fault 3</li> <li>• Internal Fault 4</li> <li>• Internal Fault 5</li> <li>• Internal Fault 6</li> <li>• Internal Fault 7</li> <li>• Internal Fault 8</li> <li>• Internal Fault 9</li> <li>• Internal Fault 0</li> <li>• Personality Fault</li> <li>• AD Offset Fault</li> <li>• Remote Keypad Lost</li> <li>• Assertion Level Fault</li> <li>• Follower Lost</li> <li>• ISO Comm Fault</li> <li>• SPI Timeout</li> <li>• Invalid Message Received</li> <li>• Network Timeout</li> </ul>
8	Idle Time	Current amount of time that the agitator has been off while the agitator is in production.
9	Agitator Halt Status	If the auxiliary input on the pump control or tank control is set up for Agitator Halt, this field displays the current status.
10	Active Profile	Current agitator profile. <ul style="list-style-type: none"> <li>• 0–2</li> </ul>
11	Actual Hertz	Current variable frequency drive/inverter operating frequency.
12	Actual Percent	Current variable frequency drive/inverter operating percentage. <ul style="list-style-type: none"> <li>• Direct Drive: 100% = 18 Hz</li> <li>• Back Gear: 100% = 43 Hz</li> </ul>

Ref.	Item	Description
13	Actual RPM	Current agitator blade speed. <ul style="list-style-type: none"> <li>• Direct Drive: 0-500 RPM</li> <li>• Back Gear: 0-50 RPM</li> </ul>
14	Set Point	Set point for agitator: <ul style="list-style-type: none"> <li>• Percentage: 0 -100%</li> <li>• Hertz: <ul style="list-style-type: none"> <li>– Direct Drive: 2-18 Hz</li> <li>– Back Gear: 2-43 Hz</li> </ul> </li> <li>• RPM: <ul style="list-style-type: none"> <li>– Direct Drive: 55-500 RPM</li> <li>– Back Gear: 2.4-50 RPM</li> </ul> </li> </ul>
15	Actual Level	Current tank level percentage.
16	Last Tank Level	Last tank level at which the agitator speed was updated when using agitator profiles.
17	On Time	Current on time for the agitator in minutes when using agitator profiles.
18	Off Time	Current off time for the agitator in minutes when using agitator profiles.
19	Load	Current agitator load as a percentage of the drivers output current rating.
20	Profiles	Each column (#1-#2) displays the settings of an agitator profile. When one of these profiles is selected, the chosen column is highlighted in green.
21	Profile Select	Press one of the following to choose the profile and set operation parameters for the agitator:  Turn off the pump.  Turn off the pump.  Select Profile 1, if created.  Select Profile 2, if created.

### View the Pumps Screen

The Pumps screen displays component-level information for the pump in each station. From this screen, you can navigate directly to any Station screen and you can view current operational data for any selected pump in the system.



Press  on any Run screen to display the Pumps screen. Each row of controls represents one station that has been created and configured through the Intelligent Paint Kitchen software.



Figure 89 Pumps Screen

You can perform any of the following tasks from the Pumps screen:

Task	Action
Enable a station	In the <b>Production</b> column for the station, press <b>Off</b> . The button changes to <b>On</b> and turns green to indicate that the station is successfully enabled.
Disable a station	In the <b>Production</b> column for the station, press <b>On</b> . The button changes to <b>Off</b> and turns blue to indicate that the station is disabled.
View the Station Status screen for a station	Press the <b>Station</b> button for the station. See <a href="#">Station Status Screen, page 106</a> .

You can view the following information for each pump in the Intelligent Paint Kitchen system:

Item	Description
Pressure	<p>Read-only. Indicates the current pressure at the outlet of the pump.</p> <p>Depending on the configuration, this column displays the following:</p> <ul style="list-style-type: none"> <li>• For pumps without a pressure sensor, this column displays percentage of force.</li> <li>• For pumps with a pressure sensor, this column displays pressure in psi, bar, or MPa.</li> <li>• If the system has two pressure transducers, only the pressure on Port 7 is displayed.</li> </ul> <p>To change the units of measure for the pump, see <a href="#">Set Up Tank Control Modules, page 73</a>.</p>
Flow	<p>Read-only. Indicates the output of the pump in liters per minute, gallons per minute, cubic centimeters (cc) per minute, ounces (oz) per minute, or cycles per minute, as chosen when the pump was set up.</p>
Speed	<p>Read-only. Indicates the current operating speed of the pump in cycles per minute.</p>
Status	<p>Read-only. Indicates the current operating condition of the pump:</p> <ul style="list-style-type: none"> <li>• Stopped</li> <li>• Stalled</li> <li>• Running</li> <li>• Stopped—Deviation</li> <li>• Stopped—Alarm</li> <li>• Stopped—Advisory</li> <li>• Stalled—Deviation</li> <li>• Stalled—Advisory</li> <li>• Running—Deviation</li> <li>• Running—Advisory</li> </ul>

## View the Tanks Screen

The Tanks screen displays fluid level and agitator speed information for every Primary Tank and Secondary Tank in the Intelligent Paint Kitchen system. From this screen, you can navigate directly to any Station screen and you can view current operational data for the Primary Tank or Secondary Tank in the system.

Each row on the screen represents one station that has been created and configured using the Intelligent Paint Kitchen software.



Press  on any Run screen to display the Tanks screen. Each row of controls represents one station that has been created and configured through the Intelligent Paint Kitchen software.

Production	#	Station Name	Primary	Speed	Secondary	Speed
On	01	Station STATION 1	0% 0.0 Gal	0.0 Hz	0%	0.0 L
On	02	Station STATION 2	0%	30.00 %	0%	0.0 %
On	03	Station STATION 3	0%	0.00 Hz	0%	0.0 Hz
On	04	Station STATION 4	0%	0.0 Hz	0%	0.0 Hz
On	05	Station STATION 5	0%	0.0 Hz	0%	0.0 Hz
Off	06	Station STATION 6	0%	0.0 Hz	0%	0.0 Hz
Off	07	Station STATION 7	0%	0.0 Hz	0%	0.0 Hz
Off	08	Station STATION 8	0%	0.0 Hz	0%	0.0 Hz
Off	09	Station STATION 9	0%	0.0 Hz	0%	0.0 Hz
Off	10	Station STATION 10	0%	0.0 Hz	0%	0.0 Hz

 1/2 

10-09-19 03:43 PM  
Master









Figure 90 Tanks Screen



You can perform any of the following tasks from the Tanks screen:

Task	Action
Enable a station	In the <b>Production</b> column for the station, press <b>Off</b> . The button changes to <b>On</b> and turns green to indicate that the station is successfully enabled.
Disable a station	In the <b>Production</b> column for the station, press <b>On</b> . The button changes to <b>Off</b> and turns blue to indicate that the station is disabled.
View the Station Status screen for a station	Press a <b>Station</b> button for the station. See <a href="#">Station Status Screen, page 106</a> .

You can view the following information for each tank or drum in the Intelligent Paint Kitchen system.

Item	Description
Primary	Read-only. Indicates the current level (0–100%) of the Primary Tank in the selected station.
Speed	Read-only. Indicates the current speed of the agitator (if present) in the Primary Tank. Each agitator's speed is displayed using the units (RPM, Hz, or %) specified during setup. See <a href="#">Set Up Tank Control Modules, page 73</a> .
Secondary	Read-only. Indicates the current level (0–100%) of the Secondary Tank in the selected station.
Speed	Read-only. Indicates the current speed of the agitator (if present) in the Secondary Tank.

## View System and Component Status

The color of a component's icon (green, red, yellow, no color) indicates its current status.

If the light tower kit is installed, the lights indicate the system status as follows:

Color	Meaning
Green	Operation is normal.
Yellow	A deviation has occurred. The system continues to run.
Red	An alarm has occurred. System has stopped.
No color	The system is not operating.

## Remote Operation Using the Touchscreen Box

The Touchscreen Box (J) allows users to view logs and software screens from a remote device.

### Setup

To remotely access the Touchscreen Box, configure Port 1 and connect it to the facility network.

- To configure Port 1, see [Network Setup and Configuration, page 94](#).
- Connect an Ethernet cable to Port 1 on the bottom of the Touchscreen Box. See the Touchscreen Connections section in [Touchscreen Box \(J\) 25A693, page 21](#).

### Access

After an IP address is established and connected, open a web browser. In the address bar, type the IP address assigned to the Touchscreen Box. If the connection is successful, the following screen appears:

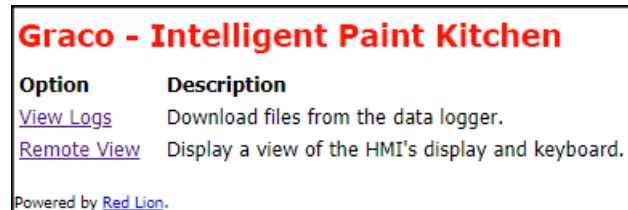

Figure 91 Removable Disk

Click **View Logs** or **Remote View** to display information from the connected Intelligent Paint Kitchen system.

- **View Logs:** Use this function to access all log files on the unit in CSV format. Logs can only be viewed; they cannot be downloaded. The following data is available for stations 1–20:
    - Pump Flow Rate: Recorded 5-second intervals
    - Pump Cycle Per Minute: Recorded 5-second intervals
    - Pump Force: Recorded 5-second intervals
    - Pump Pressure 1: Recorded 5-second intervals
    - Pump Pressure 2: Recorded 5-second intervals
    - Primary Agitator Frequency: Recorded 5-second intervals
    - Secondary Agitator Frequency: Recorded 5-second intervals
    - Primary Tank Level: Recorded 60-second intervals
    - Secondary Tank Level: Recorded 60-second intervals
  - **Remote View:** Use this function to navigate all screens on the Touchscreen interface. You can only view current information on the Touchscreen interface; you cannot control the Intelligent Paint Kitchen system. For more information, including screen graphics, see [Touchscreen Software, page 59](#).
- NOTE:** Navigating on the web browser causes the screens to change on the Touchscreen interface. If others are accessing the Touchscreen interface, they will see the remote navigation. Make sure the remote and local operations do not conflict with each other.

# Events and Logs

System errors alert you of a problem and help prevent failures in the Intelligent Paint Kitchen from occurring. There are three types of events: Advisory, Deviation, and Alarm.

An **Advisory** records an event in the system and clears itself after 60 seconds. The four digit code is followed by “-V”.

A **Deviation** records an error in the system but does not shut down the equipment. The deviation must be acknowledged by the user. The four digit code is followed by “-D”.

If an **Alarm** occurs, operation of the affected station stops. The four digit code is followed by “-A”.

If any of the system error types occur:

- Alarm buzzer sounds (unless in silent mode).
- Alarm popup screen shows the active alarm code (see [Error Codes, page 125](#)).
- Status bar on the Advanced Display Module shows the active alarm code.
- Alarm is saved in the date/time stamped log.

A **Record** saves relevant system events in the background. These are informational only and can be reviewed on the Events screen, which displays the 200 most recent events, with date, time, and description.

Use the following procedures to set up and specify how events are generated and responded to.

## Set Up Events

Use this procedure to specify how Intelligent Paint Kitchen events are handled by the system. You can specify how events are handled for different parts of the pump system from the Pump Events screen.

- Press **IO Status** to set up I/O status events.
- Press **Display** to set up events as they display onscreen.
- Press **Pump 1** to set up event handling for the first pump in the system.
- Press **Pump 2** to set up event handling for the second pump in the system.

## Respond to Events

**NOTE:** When a deviation or alarm occurs, be sure to determine the error code before resetting it. If you forget which code occurred, go to the [View the Event Log, page 124](#), to view the last 200 errors, with date and time stamps.

If an alarm has occurred, correct the cause before resuming operation.

On the Event screen, do one of the following:

- Press **Acknowledge** to reset the displayed event.
- Press **Acknowledge All** to reset all current Intelligent Paint Kitchen events.

## View the Event Log

The Event Log contains a record of all advisories, deviations, and alarms that have occurred in the system. Events are listed sequentially, with the most recent event appearing at the top of the screen.

This screen is read-only. It provides the following information about each recorded event:

- Date and time the event occurred.
- Station number where the event occurred.
- The error code that was detected. Go to the [Error Codes, page 125](#) to view a full description of each error code,
- A brief description of the event.

Event Log							Clear Log
#	Date	Time	Station #	Station Name	Error Code	Description	
1	10-09-19	03:29:37 PM	2	STATION 2	CAG2-A	Comm. Alarm Pump	 01/17 
2	10-09-19	03:29:26 PM	2	STATION 2	CAG2-A	Comm. Alarm Pump	
3	10-09-19	03:29:19 PM	2	STATION 2	CAG2-A	Comm. Alarm Pump	
4	10-09-19	03:28:14 PM	2	STATION 2	CAG2-A	Komm. Alarmpumpe	
5	10-07-19	09:31:52 AM	2	STATION 2	CAG2-A	Comm. Alarm Pump	
6	10-03-19	12:12:45 PM	0		CAG6-A	Comm. Alarm Supervisor 1	
7	10-01-19	12:55:20 PM	2	STATION 2	CAG2-A	Comm. Alarm Pump	
8	10-01-19	12:54:14 PM	2	STATION 2	CAG2-A	Comm. Alarm Pump	
9	09-30-19	05:02:25 PM	3	STATION 3	F_81-A	DSI-Kommunikation Verlust	
10	09-30-19	05:00:18 PM	3	STATION 3	F_81-A	DSI-Kommunikation Verlust	
11	09-30-19	04:37:16 PM	0			Event Log File couldn't be created	
12	09-30-19	04:37:09 PM	3	STATION 3	F_81-A	DSI Comm. Loss	

10-09-19 03:33 PM  
Master













Figure 92 Event Log Screen

1. Press  on any Run screen to enter the Event Log screen.
2. Press  or  to scroll through the event log.

## Error Codes

**NOTE:** When an error occurs be sure to determine the code before resetting it. If you forget which code occurred, see [View the Event Log, page 124](#) to view the last 200 errors, with date, time, station number, and description.

### Allen Bradley PowerFlex 4M Errors

Code	Fault	Problem	Solution
F2	Auxiliary Input	Auxiliary input interlock is open.	<ul style="list-style-type: none"> <li>Check the remote wiring.</li> <li>Verify communications programming for intentional fault.</li> </ul>
F3	Power Loss	Excessive DC Bus voltage ripple.	<ul style="list-style-type: none"> <li>Monitor the incoming line for phase loss or line imbalance.</li> <li>Check the input line fuse.</li> </ul>
F4	Undervoltage	DC bus voltage fell below the minimum value.	Monitor the incoming AC line for low voltage or line power interruption.
F5	Overvoltage	DC bus voltage exceeded the maximum value.	Monitor the AC line for high line voltage or transient conditions. Bus overvoltage can also be caused by motor regeneration. Extend the decel time install a dynamic brake option.
F6	Motor Stalled	The drive is unable to accelerate the motor.	Increase P109 and/or A402 (accel time) or reduce the load so the drive output current does not exceed the current set by the Current Limit parameter (A441).
F7	Motor Overload	Internal electronic overload trip.	<ul style="list-style-type: none"> <li>An excessive motor load exists. Reduce the load so the drive output current does not exceed the current set by the Motor OL Current parameter (P103).</li> <li>Verify the Boost Select setting (A453).</li> </ul>
F8	Heatsink Overtemperature	Heatsink temperature exceeds a predefined value.	<ul style="list-style-type: none"> <li>Check for blocked or dirty heat sink fins. Verify that the ambient temperature has not exceeded 40° C (104° F) for IP 30/NEMA 1/UL Type 1 installations or 50° C (122° F) for IP10/Open type installations.</li> <li>Check the fan.</li> </ul>
F12	HW Overcurrent (300%)	The drive output current has exceeded the hardware current limit.	Check the programming. Check for excess load, an improper Boost Select setting (A453), DC brake volts set too high, or other causes of excess current.
F13	Ground Fault	A current path to the earth ground has been detected at one or more of the drive output terminals.	Check the motor and external wiring to the drive output terminals for a grounded condition.
F33	Auto Restart Tries	The drive unsuccessfully attempted to reset a fault and resume running for the programmed number of auto restart tries (A451).	Correct the cause of the fault and manually clear.

Events and Logs

Code	Fault	Problem	Solution
F38	Phase U to Ground Short	A phase to ground fault has been detected between the drive and motor in this phase.	<ul style="list-style-type: none"> <li>• Check the wiring between the drive and motor.</li> <li>• Check the motor for a grounded phase. Replace the drive if the fault cannot be cleared.</li> </ul>
F39	Phase V to Ground Short		
F40	Phase W to Ground Short		
F41	Phase UV Short	Excessive current has been detected between these two output terminals.	<ul style="list-style-type: none"> <li>• Check the motor and drive output terminal wiring for a shorted condition.</li> <li>• Replace the drive if the fault cannot be cleared.</li> </ul>
F42	Phase UW Short		
F43	Phase VW Short		
F48	Parameters Defaulted	The drive was commanded to write default values to EEPROM.	<ul style="list-style-type: none"> <li>• Clear the fault or cycle power to the drive.</li> <li>• Program the drive parameters as needed.</li> </ul>
F63	Software Overcurrent	The programmed SW Current Trip (A448) has been exceeded.	Check the load requirements and the SW Current Trip setting (A448).
F64	Drive Overload	A drive rating of 150% for one minute or 200% for three seconds has been exceeded.	Reduce the load or extend accel time.
F70	Power Unit	Failure has been detected in the drive power section.	<ul style="list-style-type: none"> <li>• Cycle power.</li> <li>• Replace the drive if the fault cannot be cleared.</li> </ul>
F71	Net Loss	The communication network has faulted.	<ul style="list-style-type: none"> <li>• Cycle power.</li> <li>• Check the communications cabling.</li> <li>• Check the network adapter setting.</li> <li>• Check the external network status.</li> </ul>
F81	Communication Loss	The RS-485 (DSI) port stopped communicating.	<ul style="list-style-type: none"> <li>• If the adapter was not intentionally disconnected, check the wiring to the port. Replace the wiring, port expander, adapters, or the complete drive as required.</li> <li>• Check the connection.</li> <li>• Determine if an adapter was intentionally disconnected.</li> <li>• Turn off using Comm Loss Action (C304).</li> </ul>
F100	Parameter Checksum Error	The checksum read from the board does not match the checksum calculated.	Set the Reset To Defaults parameter (P112) to option 1 (reset defaults).
F122	I/O Board Fail	Failure has been detected in the drive control and I/O section.	<ul style="list-style-type: none"> <li>• Cycle power.</li> <li>• Replace the drive if the fault cannot be cleared.</li> </ul>

## Lenze Errors



Code	Fault	Problem	Solution
F_AF	High Temperature	The drive is too hot inside.	<ul style="list-style-type: none"> <li>Reduce the drive load.</li> <li>Improve cooling.</li> </ul>
F_AL	Assertion Level	<ul style="list-style-type: none"> <li>The Assertion Level switch is changed during operation.</li> <li>P120 is changed during operation.</li> <li>P100 or P121–P124 are set to a value other than 0, and P120 does not match the Assertion Level switch.</li> </ul>	Before setting P199 or P121–P124, make sure the Assertion Level switch and P120 are both set for the type of input devices.
F_bF	Personality	Drive Hardware	<ul style="list-style-type: none"> <li>Cycle power.</li> </ul>
F_CF	Control	An EPM has been installed that is either blank or corrupted.	<ul style="list-style-type: none"> <li>Power down and install an EPM with valid data.</li> </ul>
F_cF	Incompatible EPM	An EPM has been installed that contains data from an incompatible parameter version.	<ul style="list-style-type: none"> <li>Reset the drive back to the defaults (3,4 for P199) and then reprogram.</li> </ul>
F_cFt	Forced Translation	An EPM from an old drive put in the new drive causes the drive to trip this fault.	Press M (the mode button) twice to reset.
F_dbF	Dynamic Braking	Dynamic braking resistors are overheating.	<ul style="list-style-type: none"> <li>Increase active decel time (P105, P126, P127).</li> <li>Check mains voltage and P107.</li> </ul>
F_EF	External	<ul style="list-style-type: none"> <li>P121–P124 = 21 and that digital input has been opened.</li> <li>P121–P124 = 22 and that digital input has been closed.</li> </ul>	<ul style="list-style-type: none"> <li>Correct the external fault condition.</li> <li>Make sure digital input is set properly for NC or NO circuit.</li> </ul>
F_F1	EPM	EPM is missing or defective.	Power down and replace the EPM.
F_F2 through F_F12	Internal	Contact technical support.	
F_Fnr	Control Configuration	The drive is set up for Remote Keypad control (P100=2 or 5), but is not set up to communicate with a remote keypad.	Set P400=1 or P600=1.
		The drive is set up for Network Only control (P100=3), but is not set up for network communications.	Set P400 or P600 to a valid network communications protocol selection.
F_FoL	TB25 (4–20 mA signal) Threshold	4–20 mA signal (at TB-25) drops below the value set in P164.	<ul style="list-style-type: none"> <li>Check the signal and signal wire.</li> <li>Refer to parameters P163 and P164.</li> </ul>
F_GF	OEM Defaults Data	The drive is powered up with P199=1 and OEM settings in the EPM are not valid.	Install an EPM containing valid OEM defaults data or change P199 to 0.
F_HF	High DC Bus Voltage	Mains voltage is too high.	Check mains voltage and P107.
		Decel time is too short, or there is too much regen from the motor.	Increase the active decel time (P105, P126, P127) or install a Dynamic Braking option.

Code	Fault	Problem	Solution
F_IL	Digital Input Configuration (P121–P124)	More than one digital input is set for the same function.	Each setting can be used once (except settings 0 and 3).
		Only one digital input is configured for the MOP function (Up, Down).	One input must be set to MOP Up, and another must be set to MOP Down.
		PID mode is entered with the setpoint reference and feedback source set to the same analog signal.	Change the PID setpoint reference (P121–P124) or feedback source (P201).
		One of the digital inputs (P121–P124) is set to 10 and another is set to 11–14.	Reconfigure the digital inputs.
		One of the digital inputs (P121–P124) is set to 11 or 12 and another is set to 13 or 14.	Reconfigure the digital inputs.
		PID is enabled in Vector Torque mode (P200=1 or 2 and P300=5).	PID cannot be used in Vector Torque mode.
F_JF	Remote Keypad	The remote keypad is disconnected.	Check the remote keypad connections.
F_LF	Low DC Bus Voltage	The mains voltage is too low.	Check the mains voltage.
F_nId	No Motor ID	An attempt was made to start the drive in Vector or Enhanced V/Hz mode before performing the Motor Auto-calibration.	Refer to parameters P300–P399 for Drive Mode setup and calibration.
F_ntF	Module Communication	Communication failure between the drive and the network module.	Check the module connections.
F_nF1 through F_nF9	Network	Refer to the module documentation for causes and remedies.	
F_OF	Output fault: Transistor fault	Output short circuit.	Check the motor and motor cable.
		Acceleration time was too short.	Increase P104 and P125.
		Severe motorload due to a mechanical problem or the drive/motor is too small for the application.	<ul style="list-style-type: none"> <li>Check the machine and the system.</li> <li>Verify that the drive and motor are the proper size for the application.</li> </ul>
		Boost values are too high.	Decrease P168 and P169.
		Excessive capacitive charging current of the motor cable.	<ul style="list-style-type: none"> <li>Use shorter motor cables with lower charging current.</li> <li>Use low capacitance motor cables.</li> <li>Install a reactor between the motor and the drive.</li> </ul>
		Failed output transistor.	Contact technical support.
F_OF1	Output fault: Ground fault	Grounded motor phase.	Check the motor and motor cable.
		Excessive capacitive charging current of the motor cable.	Use shorter motor cables with a lower charging current.



Code	Fault	Problem	Solution
F_PF	Motor Overload	Excessive motor load for too long.	<ul style="list-style-type: none"> <li>• Verify that P108 is set properly.</li> <li>• Verify that the drive and motor are the proper size for the application.</li> </ul>
F_rF	Flying Restart	The controller was unable to synchronize with the motor during a restart attempt (P110=5 or 6).	Check the motor and load.
F_SF	Single-Phase	A mains phase has been lost.	Check the mains voltage.
F_UF	Start	The Start command was present when power was applied (P110=0 or 2).	<ul style="list-style-type: none"> <li>• Wait at least two seconds after powering up to apply the Start command.</li> <li>• Consider an alternate starting method (P110).</li> </ul>
F_FAU	TB5 (0–10V signal) Threshold	0–10V signal at TB5 drops below the value set in P158.	<ul style="list-style-type: none"> <li>• Check the signal and signal wire.</li> <li>• Refer to parameters P157 and P158.</li> </ul>

E-Flo DC Errors

Display Code	Applicable Motor	Blink Code	Type	Description
None	Basic	6	Alarm	The Mode Select knob is set between Pressure  and Flow  . Set the knob to the mode you want.
None	Basic and Advanced	9	None	A blink code of 9 is not an error code, but an indicator of which pump is active.
A4N_	Basic and Advanced	6	Alarm	The motor current exceeded 13A or the hardware overcurrent tripped at 20A.
CAC_	Advanced	None	Alarm	The display detects a loss of CAN communication. Flashing alarm appears on the display, and the blink code occurs.
CAD_	Advanced	2–3	Alarm	Unit detects a loss of CAN communication. This alarm is only logged. No flashing alarm appears on the display, but the blink code does occur.
CAG_	Advanced	2–3	Deviation	The PLC has stopped pinging the register for the solenoid.
C3G_	Advanced	None	Deviation	The display detects a loss of Modbus communication when Modbus deviation is enabled on Setup Screen 16.
C4G_	Advanced	None	Alarm	The display detects a loss of Modbus communication when Modbus alarm is enabled on Setup Screen 16.
CBN_	Basic and Advanced	2–4	Deviation	Temporary circuit board communication failure.
CCN_	Basic and Advanced	3–6	Alarm	Circuit board communication failure.
END_	Basic and Advanced	5–6	Advisory	A calibration of the encoder and stroke range is in progress.
ENN_	Advanced	None	Advisory	Dual lower system calibration completed successfully.
E5F_	Advanced	None	Advisory	Dual lower system calibration error. System running too rapidly to perform calibration.
E5S_	Advanced	None	Advisory	Dual lower system calibration stopped or interrupted.
E5U_	Advanced	None	Advisory	Dual lower system calibration unsteady. System could not determine optimum setting.
EBC_	Advanced	None	Advisory	Run/Stop switch in Stop position (closed).
F1F0	Advanced	None	Alarm	Fill pump flow not detected. The Primary Tank level has not increased with the no flow timeout window and the no flow timeout event is set to alarm.
F2F0	Advanced	None	Deviation	Fill pump flow not detected. The Primary Tank level has not increased with the no flow timeout window and the no flow timeout event is set to deviation.
K1D_	Advanced	1–2	Alarm	Flow is below minimum limit.
K2D_	Advanced	None	Deviation	Flow is below minimum limit.
K3D_	Advanced	None	Deviation	Flow exceeds maximum target; also indicates pump runaway condition exists.
K4D_	Basic and Advanced	1	Alarm	Flow exceeds maximum target; also indicates pump runaway condition exists.

Display Code	Applicable Motor	Blink Code	Type	Description
L1A0	Advanced	None	Alarm	The flow rate is above the current profile flow limit set on Profile Screen 3.
L2A0	Advanced	None	Deviation	The Primary Tank level is below the Primary Tank level low deviation set point.
L3A0	Advanced	None	Deviation	The primary tank current level is above the primary tank deviation set point.
L4A0	Advanced	None	Alarm	The Primary Tank level is above the Primary Tank level high alarm set point.
L6CA	Advanced	None	Deviation	Port 8 is enabled and the current draw is less than 4 mA. The Back Pressure Regulator is requesting a value greater than 0%.
L6CB	Advanced	None	Deviation	Port 9 is enabled and the current draw is less than 4 mA.
MND_	Advanced	None	Advisory	Maintenance counter is enabled and countdown reached zero (0).
P1D_	Advanced	None	Deviation	Unbalanced load. Dual Lower system — P1D1 = Motor 1 is requiring less force to hold speed; pump lower may need service. P1D2 = Motor 2 is requiring less force than motor 1 to hold speed.
P9D_	Advanced	None	Deviation	Major unbalanced load — see P1D_ (P9D_ is higher magnitude)
P1I_	Advanced	1–3	Alarm	Pressure is below minimum limit.
P2I_	Advanced	None	Deviation	Pressure is below minimum limit.
P3I_	Advanced	None	Deviation	Pressure exceeds maximum target.
P4I_	Advanced	1–4	Alarm	Pressure exceeds maximum target.
P5DX	Advanced	None	Deviation	More than one pump is assigned to a transducer. The assignment for that transducer is automatically cleared under this condition. User must reassign.
P6CA or P6CB	Advanced	None	Deviation	For units without closed loop pressure control: Transducer (A or B) is enabled but not detected.
P6D_	Advanced	1–6	Alarm	For units with closed loop pressure control: Transducer is enabled but not detected.
T2D_	Basic and Advanced	3–5	Alarm	Internal thermistor disconnected or motor temperature is below 0° C (32° F).
T3D_	Basic and Advanced	5	Deviation	Motor over temperature. Motor will throttle itself to stay below 85° C (185° F) internally.
T4D_	Basic and Advanced	4–6	Alarm	Motor over temperature. Motor will throttle itself to stay below 85° C (185° F) internally.
V1I_	Basic and Advanced	2	Alarm	Brown out; voltage supplied to motor is too low.
V2I_	Basic and Advanced	None	Deviation	Brown out; voltage supplied to motor is too low.
V1M_	Basic and Advanced	2–6	Alarm	AC power is lost.

Events and Logs

Display Code	Applicable Motor	Blink Code	Type	Description
V3I_	Basic and Advanced	None	Deviation	Voltage supplied to motor is too high.
V4I_	Basic and Advanced	3	Alarm	Voltage supplied to motor is too high.
V9M_	Basic and Advanced	7	Alarm	Low supply voltage detected at start up.
WCW_	Advanced	None	Alarm	System type mismatch; motor is an E-Flo DC dual lower system and the display configuration does not match. Change the display's system type on the Setup Units screen (screen 15).
WMC_	Basic and Advanced	4-5	Alarm	Internal software error.
WNC_	Basic and Advanced	3-4	Alarm	Software versions do not match.
WNN_	Advanced	None	Alarm	System type mismatch; motor is an E-Flo DC single lower system and the display configuration does not match. Change the display's system type on the Setup Units screen (screen 12 in dual lower mode).
WSC_	Advanced	None	Deviation	Profile is set to 0 pressure or 0 flow.
WSD_	Advanced	1-5	Alarm	Invalid lower size; occurs if the unit is operated before setting up the lower size.
WXD_	Basic and Advanced	4	Alarm	An internal circuit board hardware failure is detected.

## Tank Control Errors

Display Code	Type	Description
L4A0	Alarm	Primary tank high
L1A0	Alarm	Primary tank low
L2A0	Deviation	Primary tank low
L1B0	Alarm	Secondary tank low
F2F0	Alarm or Deviation	No or low flow with fill pump on No tank level change detected
CAGX	Deviation	PLC handshake dropped while solenoid output on
C3GX	Deviation	Modbus communication is down
L6CA	Alarm	Radar level sensor A (Port 8) not detected
L6CB	Alarm	Radar level sensor A (Port 7) not detected
P6CA	Deviation	Pressure sensor A (Port 7) not detected
P6CB	Deviation	Pressure sensor B (Port 10) not detected

## Touchscreen Events

Display Code	Type	Description
DLD0	Advisory	Pump that is intended to be pumping during production has stopped. See the Production column at <a href="#">View the Stations Screen, page 104</a> .
H1A0	Advisory	Primary Agitator that is intended to be in production has been idle for longer than the timeout period. See the Idle Timer field at <a href="#">Set Up Primary Agitator, page 77</a> , and the Production column at <a href="#">View the Stations Screen, page 104</a> .
H1B0	Advisory	Secondary Agitator that is intended to be in production has been idle for longer than the timeout period. See the Idle Timer field at <a href="#">Set Up Secondary Agitator, page 83</a> , and the Production column at <a href="#">View the Stations Screen, page 104</a> .

# Troubleshooting

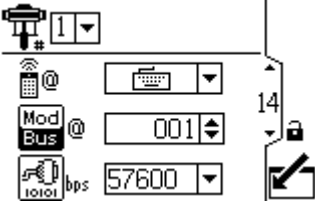
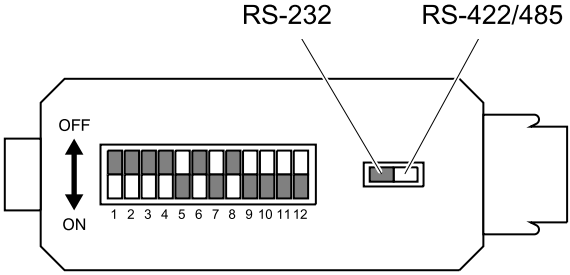

**NOTE:** Check all possible remedies before disassembling the system.

Problem	Cause	Solution
The Supervisor Box (A) cannot communicate with the Pump Control Module (PD) or the Tank Control Module (TD).	The Modbus settings are incorrect.	Make sure node communication is turned on. Verify the Modbus settings on the Pump Control Module. <ul style="list-style-type: none"> <li>• The control location is set to remote.</li> <li>• The Modbus node ID is set for the correct pump.</li> <li>• The serial port baud rate is set to 57600.</li> </ul>  <p>See <a href="#">Enter the Node IDs, page 45</a>.</p>
	The dip switch settings are incorrect.	Verify the dip switch settings on the fiber to serial converter. See <a href="#">Set DIP Switches on the Fiber Optic Converters, page 33</a> . <ul style="list-style-type: none"> <li>• Switch 1: On</li> <li>• Switch 2: On</li> <li>• Switch 3: On</li> <li>• Switch 4: On</li> <li>• Switch 5: Off</li> <li>• Switch 6: On</li> <li>• Switch 7: Off</li> <li>• Switch 8: On</li> <li>• Switch 9: Off</li> <li>• Switch 10: Off</li> <li>• Switch 11: Off</li> <li>• Switch 12: Off</li> <li>• Main Switch: Set to RS-422/485</li> </ul>  <p style="text-align: right;">ti23083b</p>

Problem	Cause	Solution
	The wiring is incorrect.	Check the Modbus wiring between the Supervisor Module and the fiber to serial converter. <ul style="list-style-type: none"> <li>• A = GND</li> <li>• B = Data B(+) – Blue/White</li> <li>• C = Data A(-) – White/Blue</li> </ul>
	Fiber ports are backwards.	Verify the fiber port setup. See <a href="#">Modbus (RS-485) Wiring, page 35</a> . <ul style="list-style-type: none"> <li>• RX from ADCM Port 1 is connected to Fiber to Serial Converter TX.</li> <li>• TX from ADCM Port 2 is connected to Fiber to serial Converter RX.</li> </ul>
	The fiber cable is set up incorrectly.	Verify the fiber cable setup. See <a href="#">Connect Pump and Tank Control Modules to the Supervisor Box, page 39</a> .
The Variable Frequency Drive/ Inverter (B) cannot communicate with the electric agitator.	The parameters are set up incorrectly.	Check all parameters for your version (Lenze SMVector or Allen Bradley PowerFlex 4M). See <a href="#">Digital Input Configuration, page 29</a> .
	The wiring is set up incorrectly.	Verify the wiring. See <a href="#">Wire the Variable Frequency Drive/Inverter to the Supervisor Module, page 37</a> .
The Radar Level Sensor (M, T) will not power on.	Node communication is not enabled.	Turn on node communication. See <a href="#">Turn on Node Communication, page 69</a> .
	The Radar Level Sensor is not connected to the correct port.	Verify that the Radar Level Sensor (M, T) is connected to the correct port. See <a href="#">Connect a Radar Level Sensor to a Pump Control Module or Tank Control Module, page 28</a> .
	The power is not turned on.	Make sure the box is enabled to turn on power in the setup screens. See <a href="#">Connect a Radar Level Sensor to a Pump Control Module or Tank Control Module, page 28</a> .
The Touchscreen Box (J) cannot communicate with the Supervisor Box (A).	The IP settings are incorrect.	Verify that the IP address settings for Port 2 are correct. See <a href="#">Network Setup and Configuration, page 94</a> .
	The Ethernet cables are plugged into the wrong port.	Verify that the Ethernet connection between the Supervisor Box and the Touchscreen Box. See <a href="#">Connect the Supervisor Box to the Touchscreen Box, page 42</a> .

# System Software Tasks

## View Software Versions

Use these steps to display the currently installed versions of software in your Intelligent Paint Kitchen components.

1. Press  on any Run screen to enter the Setup menu screen.

2. Press **Versions**.
3. On the Versions screen, press **IPK**, **EFlo-DC**, or **Tank Control** to view the installed software version for the selected components.

## Utilities Menu Structure

Button	Description
SD Card	Press to format, use, or eject an SD card in the Touchscreen Box. Follow the procedure in <a href="#">Use an SD Card, page 138</a> .
USB	Press to format, use, or eject an USB drive in the Touchscreen Box. A USB device may be used to update the Intelligent Paint Kitchen firmware. Follow the procedure in <a href="#">Use a USB Drive, page 138</a> .
Touch Calibration	Press to calibrate the Touchscreen interface. Follow the procedure in <a href="#">Calibrate the Touchscreen Interface, page 137</a> .
Touch Tester	Press to test the Touchscreen interface and determine whether calibration is needed. Follow the procedure in <a href="#">Test the Touchscreen Interface, page 136</a> .

## Test the Touchscreen Interface

Use these steps to test the Touchscreen interface. This test ensures that the onscreen buttons and controls display in the correct locations and can be engaged by pressing on the screen.

1. Press  on any Run screen.
2. On the Setup Menu screen, press **Utilities**.

3. On the Utilities Menu screen, press **Touch Tester**.
4. On the Test Calibration screen, follow the instructions to test the Touchscreen interface.
5. If needed, see [Calibrate the Touchscreen Interface, page 137](#) to recalibrate the Touchscreen interface.
6. Press the home icon  to return to the Stations screen.



## Calibrate the Touchscreen Interface

If pressing a control on the Touchscreen interface does not display the screen, calibrate the Touchscreen interface.

Proper calibration helps ensure that the displayed button, field, key, or icon corresponds to the location to press to select that control.

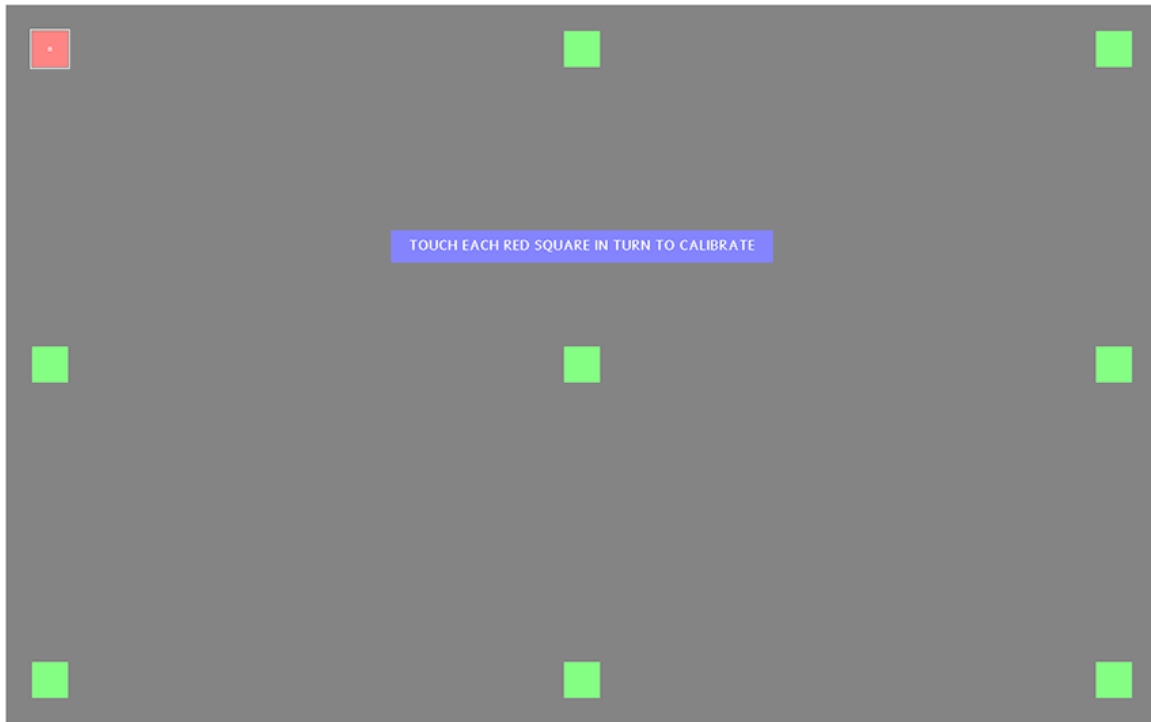



Figure 93 Touchscreen Calibration Screen

1. Press  on any Run screen.
2. On the Setup Menu screen, press **Utilities**.
3. On the Utilities Menu screen, press **Touch Calibration**.
4. On the Touch Calibration screen, follow the prompts. The green squares turn red, one at a time. Press each red square as it appears.
5. When finished, the “Calibration Was Successful” message displays. The screen has been recalibrated.
6. Press the home icon  to return to the Stations screen.

## Use an SD Card

An SD flash card can be inserted into a slot on the left side of the Touchscreen Module (14).

The SD card contains the Intelligent Paint Kitchen software and the user-defined settings needed to run the system. Use a 2GB SD card.

Use this procedure to insert, eject, or format an SD card.

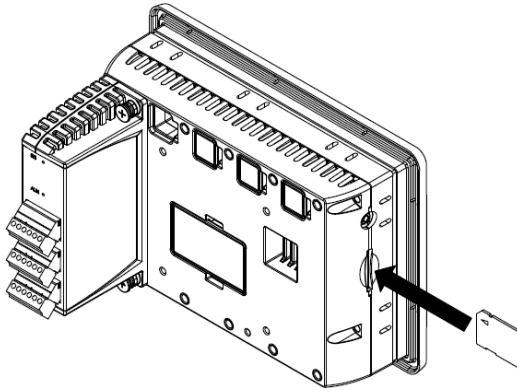



Figure 94 Insert an SD Card

1. Press  on any Run screen to enter the Setup menu screen.
2. Press **Utilities**.
3. On the Utilities Menu screen, press **SD Card**.
4. On the SD Card screen, press one of the following buttons to perform a task with the SD card:

Press **Eject** to eject the SD card from the Touchscreen Module. Physically remove the SD card from its slot on the rear of the Touchscreen Module.

Press **Format** to format a new SD card that has been inserted into the Touchscreen Module.

Press **Mount** to begin using an SD card that has been inserted and formatted.

## Use a USB Drive

A USB drive can be inserted into the designated port on the bottom of the Touchscreen Module (14).

A USB device is used to store the log files generated by the Intelligent Paint Kitchen system. You can

remove the USB device and use to copy log files onto a computer. When you insert a correctly formatted USB device into the computer, the log files start to copy automatically.

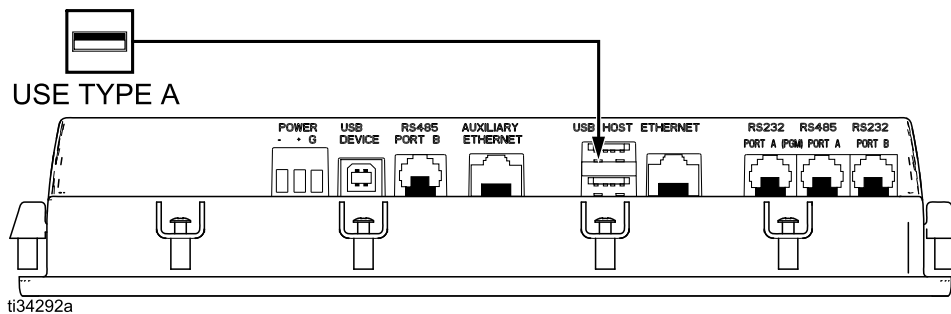



Figure 95 USB Port on the Bottom of the Touchscreen Module

1. Press  on any Run screen to enter the Setup menu screen.
2. Press **Utilities**.
3. On The Utilities Menu screen, press **USB**.

4. On the USB screen, press one of the following buttons to perform a task with the USB drive:



Press **Eject** to eject the USB drive from the Touchscreen Module.

Press **Format** to format a new USB drive that has been inserted into the Touchscreen Module.

Press **Firmware Update** to use the USB drive to update the firmware.



## Set the Time and Date

Set the correct time and date so the event log registers events as they occur.

1. Press  on any Run screen.
2. On the Setup Menu screen, press **Utilities**.
3. On the Utilities Menu screen, press **Time**.
4. On the Time screen, press the current date and time displayed on the screen.
5. Use the **Label** popup to enter the current time and date. Use mm/dd/yyyy hh:mm format.
6. Press Return  to enter the changes.

# Repair

Individual items used in the Supervisor Box (A) and Touchscreen Box (J) are not repairable. If they fail, they must be replaced.

				
<ul style="list-style-type: none"><li>• To avoid electric shock, remove power from the system before servicing.</li><li>• All electrical wiring must be done by a qualified electrician and comply with all local codes and regulations.</li><li>• Do not substitute or modify system components.</li></ul>				

## Replace the Battery on the Touchscreen Module

The Touchscreen Module (14) uses a 3-volt lithium battery to run the internal clock during times when the system is not powered.

1. Disconnect the power to the Touchscreen Box.
2. Remove the battery cover on the rear of the Touchscreen Module.
3. Grasp the top edge of the battery and push to the left to remove the battery from the holder.
4. Lift the battery out and replace with a new battery. Observe the battery orientation in the figure below.
5. Replace the battery cover.
6. Reset the time and date, if necessary. See [Set the Time and Date, page 139](#).

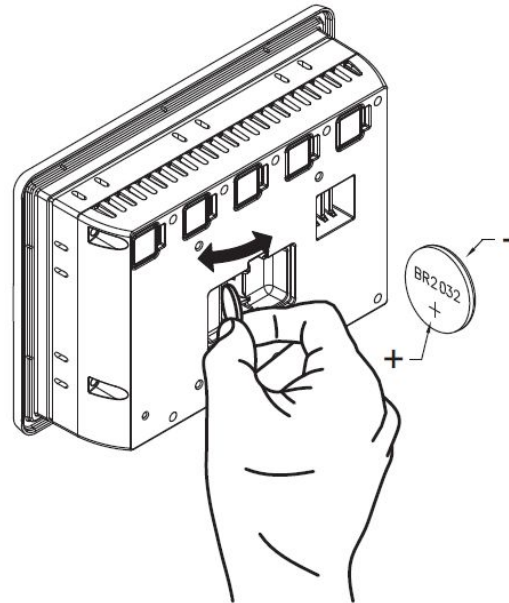



Figure 96 Insert the Battery

NOTE: Recycle batteries according to all applicable regulations. Do not dispose of batteries with household or commercial waste.

## Replace a Fiber Optic Converter

1. Disconnect the power.
2. Disconnect the + (white/blue) and – (blue) electrical wires.
3. Remove the fiber optic converter (38) from the DIN rail.
4. Attach the new fiber optic converter (38) to the DIN rail.
5. Connect the + (white/blue) wire to terminal C. Connect the – (blue) wire to terminal B.

**NOTE:** In the Supervisor Box, the wires originate from the Supervisor Module. In the Expansion Box, the wires originate from the power supply.

Wire	Terminal	Color
	B	White/Blue
	C	Blue/White

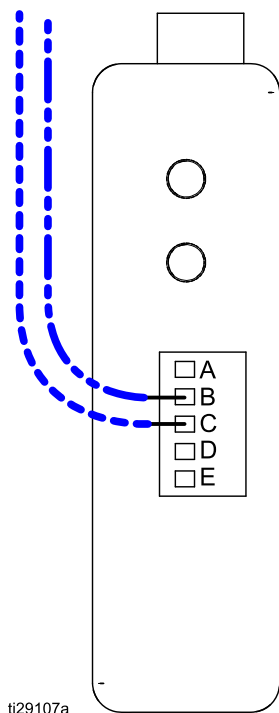







Figure 97 Connecting Fiber Optic Converter Wires

## Replace the Supervisor Module

1. Disconnect the power.
2. Disconnect + (red, white/blue) wires from connectors B, 7, and 8. Disconnect – (blue, black) wires from connectors A, 5, and 6.
3. Remove the Supervisor Module (36) from the DIN rail.
4. Install the new Supervisor Module onto the DIN rail.
5. Connect the + (white/blue) wire from the fiber optic converter (38) to terminal A on the ACS. Connect the – (blue/white) wire from the fiber optic converter to terminal B.
6. Connect the + (red) wire from the power supply (35) to terminal 8 on the ACS. Connect the – (black) wire from the power supply to terminal 6.
7. Connect the + (red) wire from terminal 6 on the Ethernet switch (37) to terminal 6 on the ACS. Connect the – (black) wire from terminal 5 on the Ethernet switch to terminal 5 on the ACS.

Wire	Color
	Red
	Blue
	Black
	White/Blue
	Blue/White

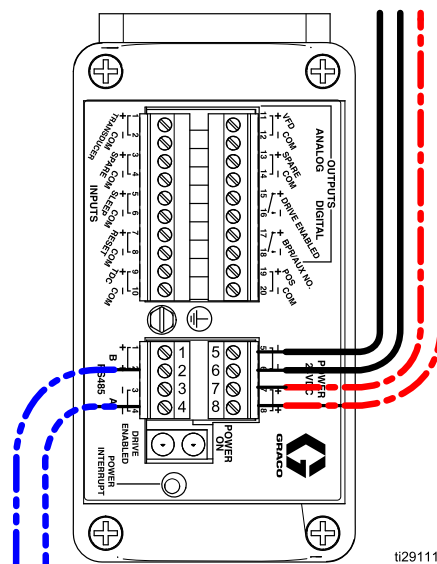

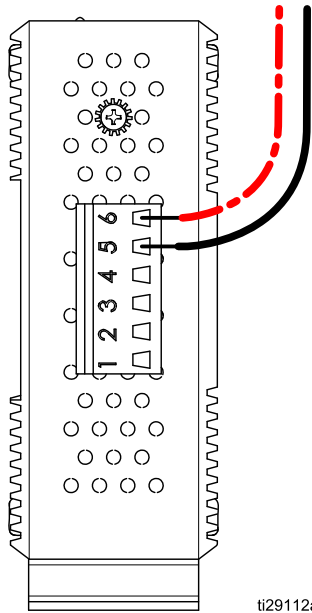

Figure 98 Connecting the Supervisor Module Wires

## Replace the Ethernet Switch for the Supervisor Module

1. Disconnect the power.
2. Disconnect the + (red) wire from connector 6. Disconnect the – (black) wire from connector 5.
3. Remove the Ethernet switch (37) from the DIN rail.
4. Install a new Ethernet switch (37) on the DIN rail.
5. Reconnect the + (red) wire from the Supervisor Module terminal 6 to terminal 6 on the Ethernet switch. Reconnect the – (black) wire from the Supervisor Module terminal 5 to terminal 5 on the Ethernet switch.

Wire	Color
	Red (24 VDC)
	Black (100–240 VAC)







ti29112a

Figure 99 Connecting the Ethernet Switch Wires

## Replace the Power Supply for the Supervisor Module

1. Disconnect the power.
2. Disconnect the + (red) wire and the – (black) wire. Also disconnect the Line (L) power wire and the Neutral (N) wire.
3. Remove the power supply (35) from the DIN rail.
4. Install a new power supply (35) onto the DIN rail.
5. Reconnect line power (L) from terminal 1 on the power switch (2) to terminal L on the power supply. Reconnect the neutral (N) wire from terminal 4 on the power switch to terminal N on the power supply.
6. Connect the + (red) wire from terminal 8 on the Supervisor Module to the + terminal on the power supply. Connect the – (black) wire from terminal 7 on the ACS module to the - terminal on the power supply.

**NOTE:** If you are replacing the power supply in the Expansion Box, the + (blue) wire connects from terminal B on the fiber optic converter to the + terminal on the power supply. The – (black) wire connects terminal A on the fiber optic converter to the – terminal on the power supply.

Wire	Color
	White (Neutral)
	Black (100–240 VAC)
	Red (24 VDC)
	Black (24 COM)

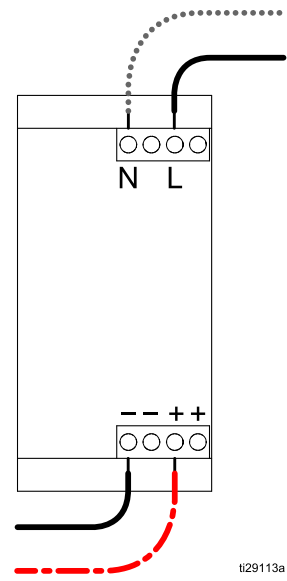

ti29113a

Figure 100 Connecting the Power Supply Wires

# Parts

## Touchscreen Box, 25A693

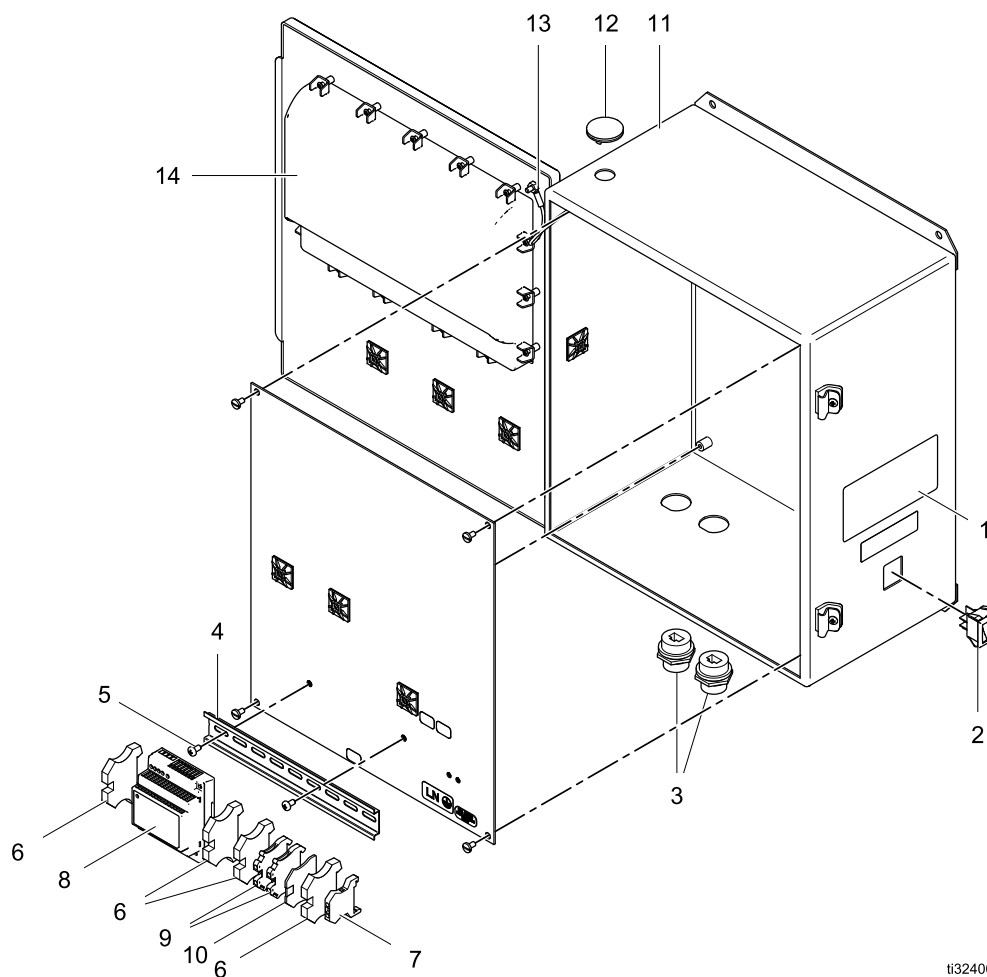

ti32400a

Ref	Part	Description	Qty
1 <sup>▲</sup>	15W776	LABEL, warning	1
2	116320	SWITCH, rocker, power	1
3	-----	CONNECTOR, Ethernet, RJ45	2
4	-----	RAIL, mounting	1
5	-----	SCREW, pan head, #10-32 x 3/8 in.	2
6	-----	BLOCK, clamp end	4
7	-----	BLOCK, terminal ground	2
8	17K909	POWER SUPPLY, 24 VDC	1

Ref	Part	Description	Qty
9	-----	BLOCK, terminal	2
10	-----	COVER, end	1
11	-----	ENCLOSURE	1
12	-----	PLUG	1
13	-----	WIRE, grounding, door	1
14	17K908	MODULE, Touchscreen control	1

<sup>▲</sup> Replacement safety labels, tags, and cards are available at no cost.

# Supervisor Box, 25A830

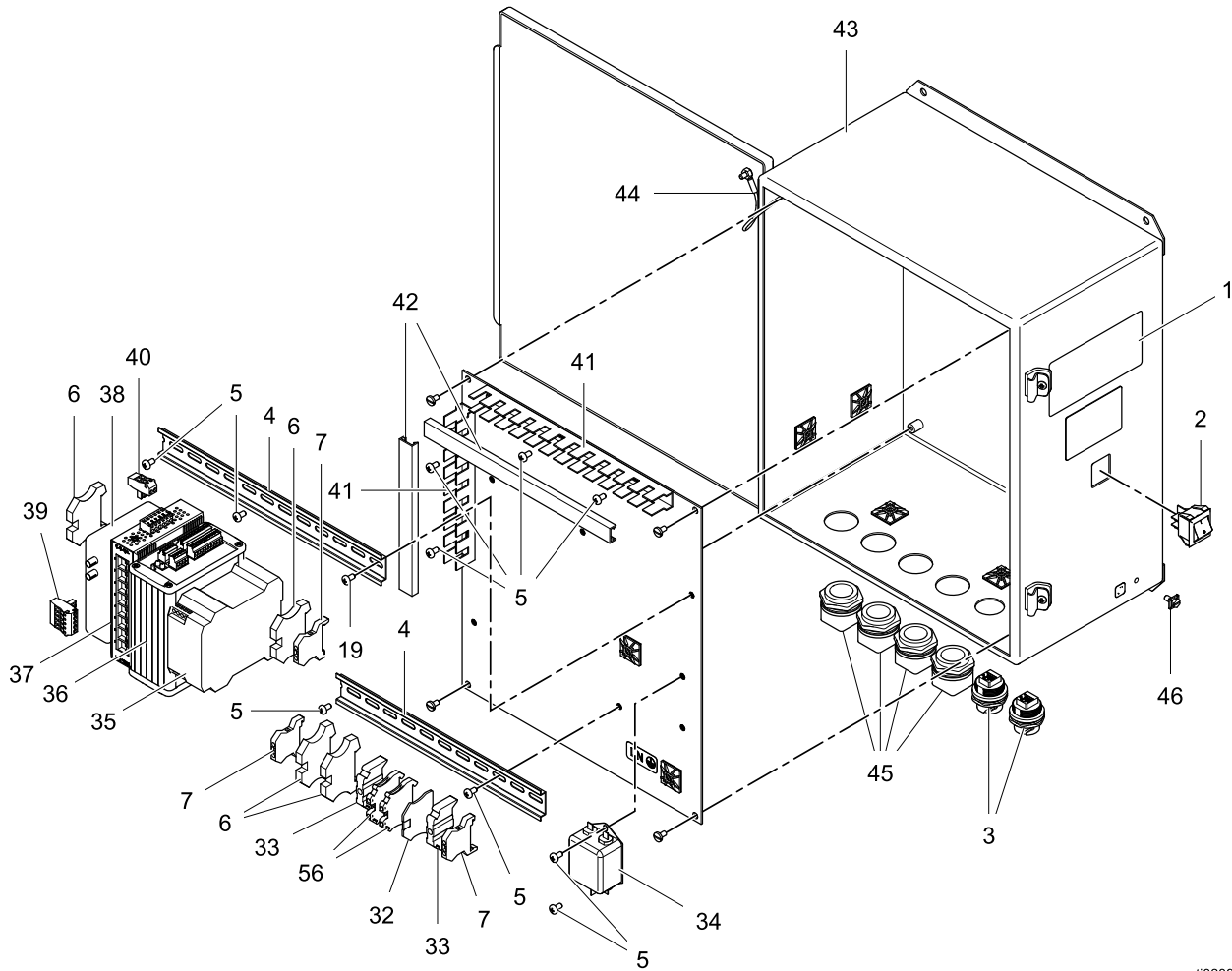

t132396a

Ref	Part	Description	Qty
1▲	15W776	LABEL, warning	1
2	116320	SWITCH, rocker, power	1
3	-----	CONNECTOR, Ethernet, RJ45	2
4	-----	RAIL, mounting	1
5	-----	SCREW, pan head, #10-32 x 3/8 in.	11
6	-----	BLOCK, clamp end	4
7	-----	BLOCK, terminal ground	2
30	-----	HOLDER, fuse, terminal block	2
32	-----	COVER, end	1
33	-----	CLAMP, end	2
34	115306	FILTER, power line	1
35	121314	POWER SUPPLY, 2 A	1
36	17R317	MODULE, Supervisor	1

Ref	Part	Description	Qty
37	15V342	SWITCH, Ethernet, 8-port	1
38	24N978	CONVERTER, serial to fiber optic	1
39	-----	CONNECTOR, circuit board, 5 position	1
40	-----	CONNECTOR, circuit board, 2 position	1
41	-----	WIREWAY, base	1
42	-----	COVER, wireway	1
43	-----	ENCLOSURE	1
44	194337	WIRE, grounding, door	1
45	-----	GROMMET, cable entry	4
46	116343	SCREW, ground	1
56	-----	BLOCK, terminal	2

▲ Replacement safety labels, tags, and cards are available at no cost.



## Expansion Box, 25A843

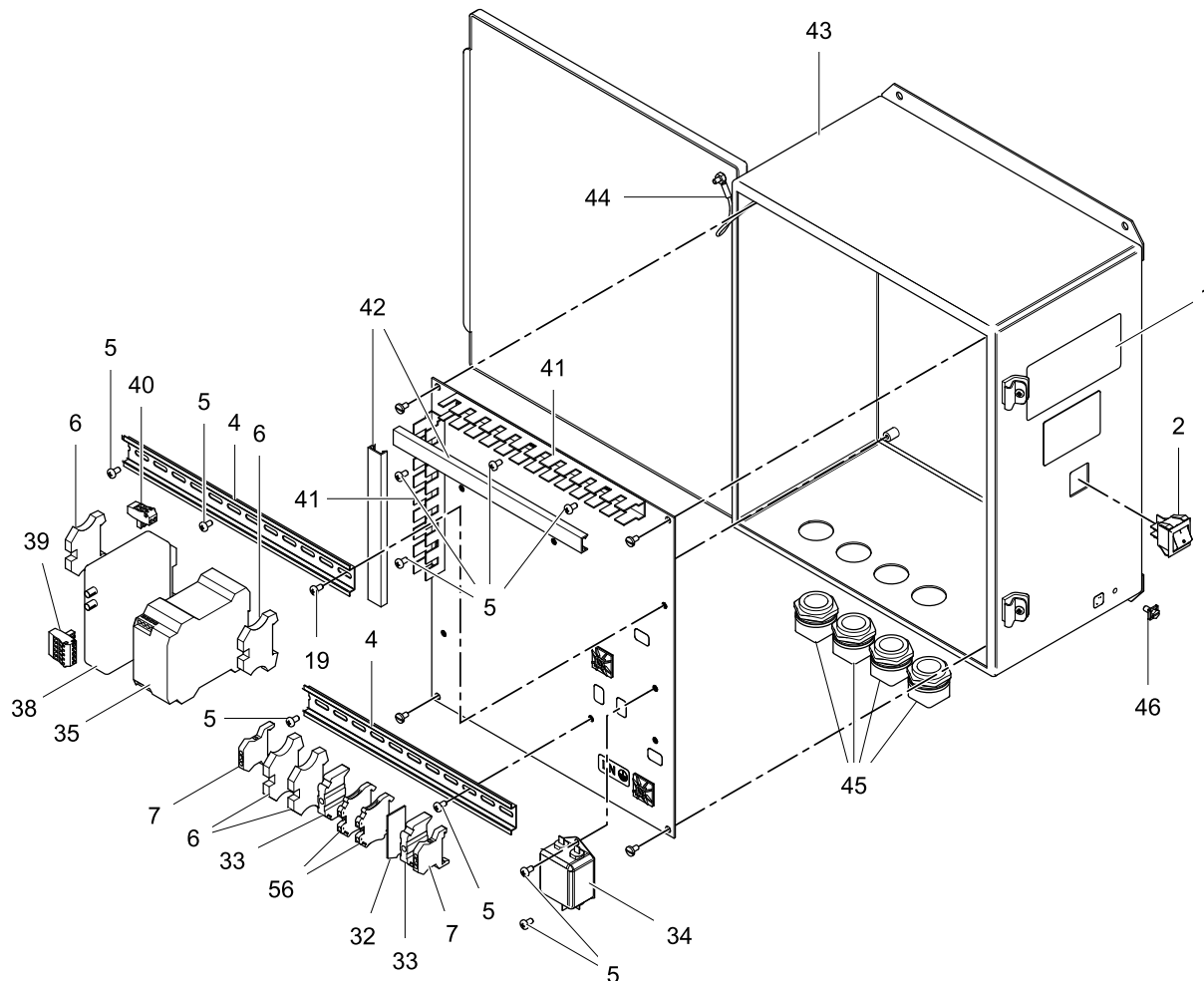

ti32410a

Ref	Part	Description	Qty
1▲	15W776	LABEL, warning	1
2	116320	SWITCH, rocker, power	1
4	-----	RAIL, mounting	1
5	-----	SCREW, pan head, #10-32 x 3/8 in.	11
6	-----	BLOCK, clamp end	4
7	-----	BLOCK, terminal ground	1
30	-----	HOLDER, fuse, terminal block	2
32	-----	COVER, end	1
33	-----	CLAMP, end	2
34	115306	FILTER, power line	1
35	121314	POWER SUPPLY, 2 A	1
38	24N978	CONVERTER, serial to fiber optic	1

Ref	Part	Description	Qty
39	-----	CONNECTOR, circuit board, 5 position	1
40	-----	CONNECTOR, circuit board, 2 position	1
41	-----	WIREWAY, base	1
42	-----	COVER, wireway	1
43	-----	ENCLOSURE	1
44	194337	WIRE, grounding, door	1
45	-----	GROMMET, cable entry	4
46	116343	SCREW, ground	1
56	-----	BLOCK, terminal	2

▲ Replacement safety labels, tags, and cards are available at no cost.

# Kits and Accessories

## Light Tower, 122193 I/O Module, 17T198

Mount the light tower accessory 122193 on top of the Supervisor Box (A) to provide visual and audible indication of alarm conditions within the Intelligent Paint Kitchen.

The I/O module 17T198 plugs into the back of the Touchscreen Box (J). For complete warnings and operation instructions, see the Beacon Tower manual 313542

Multiple lights can appear at the same time.

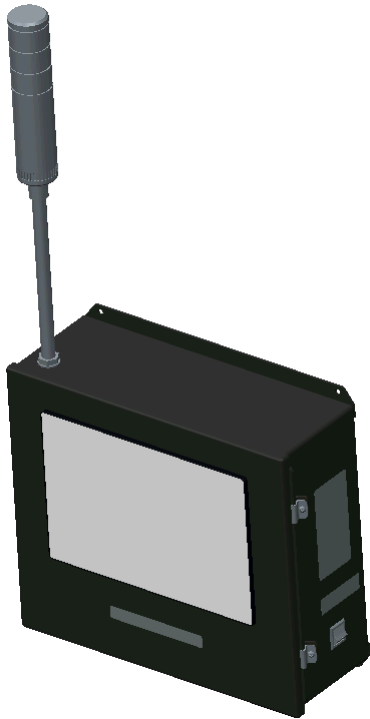

Light Signals

Signal	Description
Amber Light	The system has a deviation.
Red Light	An alarm exists. The system goes to Standby.
Green Light	Not used.
Audible Buzzer	A system warning is active. Verify the alarm. To adjust the buzzer volume, see the vendor manual.

## Transfer Pump Mounting Kit, 17S959

Install this kit to transfer fluid from the Secondary Tank (H) to the Primary Tank (G) in the hazardous location of a station. Kit includes mounting hardware for the Pneumatic Remote Transfer Fill Pump (N).

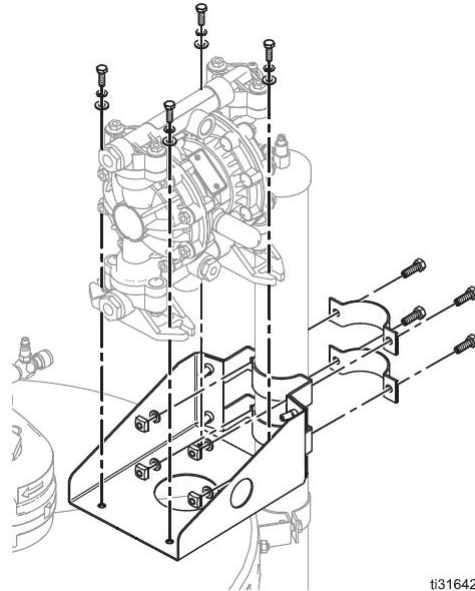

t31642a

## Cable Splitter, 17R629

Use the cable splitter to connect multiple paint kitchen components to Port 4 of the Pump Control Module (PD) or to the Tank Control Module (TD).



# Dimensions

## Touchscreen Box Dimensions

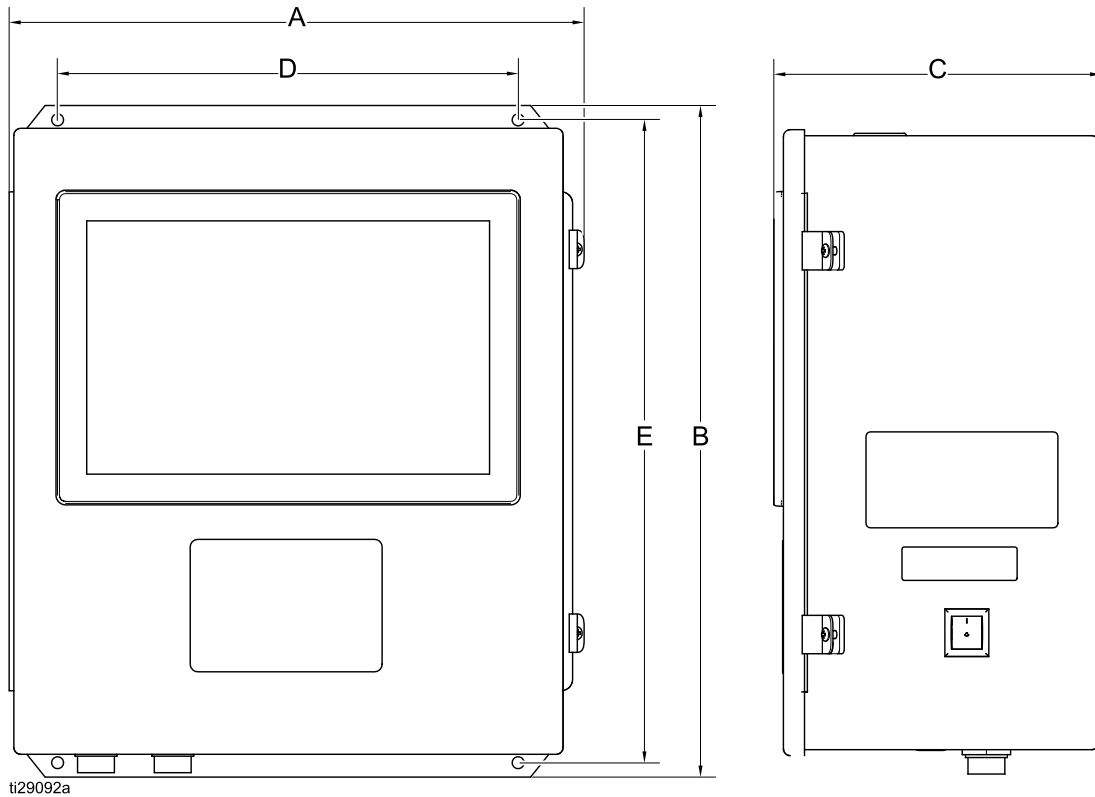

Reference	U.S.	Metric
A	15.00 in.	381.0 mm
B	17.50 in.	444.5 mm
C	8.51 in.	216.2 mm
D	12.00 in.	304.8 mm
E	16.75 in.	425.5 mm

### Supervisor Box and Expansion Box Dimensions

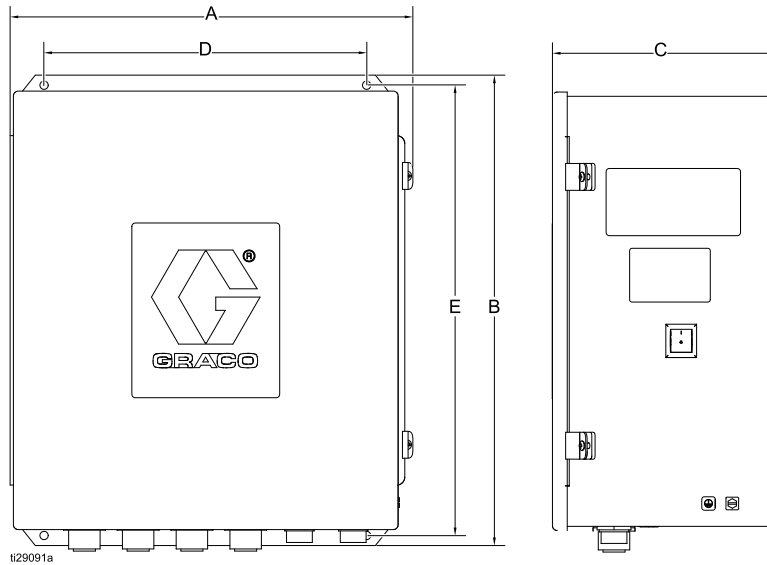

Figure 101 Supervisor Box

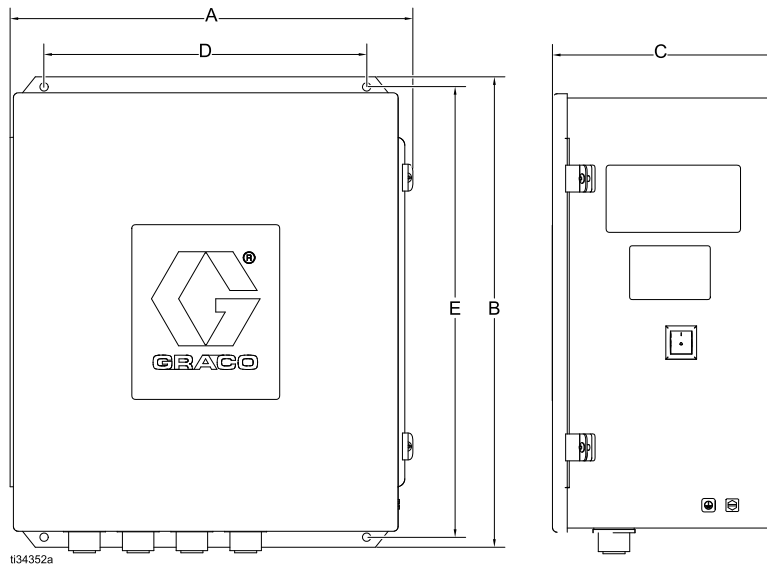

Figure 102 Expansion Box

Reference	U.S.	Metric
A	15.00 in.	381.0 mm
B	17.50 in.	444.5 mm
C	8.25 in.	209.6 mm
D	12.00 in.	304.8 mm
E	16.75 in.	425.5 mm

# Technical Specifications for the Touchscreen Box, Supervisor Box, and Expansion Box

NOTE: For components not listed in the following table, see the specific component manuals for technical specifications.

	US	Metric
<b>Electrical Power Requirements:</b>	100–240 VAC, 1.0 amp maximum, 50 or 60 Hz, single phase	
<b>Weight:</b>		
Touchscreen Box, 25A693	41 lb	18.6kg
Supervisor Box, 25A830 (as shipped)	43 lb	19.5 kg
Expansion Box, 25A843 (as shipped)	39 lb	17.7 kg
<b>Operating Temperature Range:</b>	40–120°F 41–104°F (ETL)	4–50°C 5–40°C (ETL)

## California Proposition 65

### CALIFORNIA RESIDENTS

**WARNING:** Cancer and reproductive harm — [www.P65warnings.ca.gov](http://www.P65warnings.ca.gov).

## Appendix A: System Design

If a station contains a Secondary Tank (H), a Tank Control Module (TD) is needed to provide control over the tank's agitator (R), Radar Level Sensor (M, T), and the Fill Pump Transfer Solenoid (P). Each of those devices is normally connected directly to the secondary Tank Control Module.

**NOTE:** It is possible to have a Secondary Tank without installing a Tank Control Module, but all Secondary Tank processes would then have to be controlled outside of the Intelligent Paint Kitchen system.

An Intelligent Paint Kitchen system can be set up without using a Supervisor Box (A), although doing so takes a lot of extra work.

### Select Your Paint Kitchen Components

The Intelligent Paint Kitchen system is designed for tremendous flexibility. The Intelligent Paint Kitchen software can control up to 20 stations. The components in each station can be selected specifically to meet the requirements for that specific station. That is, the components in one station do not need to match the components in any other station in the system.

For example, one station may require higher pressure operation, or one station may use greater volumes of fluid than other stations in the same system. Design your system so that each station contains pumps, tanks, and other components that specifically address the size of that station and its fluid usage requirements.

You may want to control different elements within some stations. The components you choose determine how the Intelligent Paint Kitchen interacts with each station.

Design your own Intelligent Paint Kitchen by following these general steps:

1. Specify the number of stations to be connected to the Intelligent Paint Kitchen.
2. For each station, choose the components to build that station's fluid circulation system:
  - a. One pump with a Pump Control Module (PD), sized according to output volume and pressure requirements.
  - b. One Run/Stop Switch (U), used to turn the pump on and off.
  - c. One Primary Tank (G), constructed of suitable material and with capacity to handle the required fluid volume.
  - d. One electric agitator (L), sized to fit the Primary Tank depth and to properly mix the volume of fluid inside the tank.
  - e. One Radar Level Sensor (M), used to monitor the fluid level in the Primary Tank.
  - f. One Back Pressure Regulator (E) and Back Pressure Regulator Controller (F), used to control the pressure of the fluid in the circulation lines.
  - g. One or two Pressure Transducers (K, optional) to monitor system pressure from the non-hazardous location.
  - h. Filters, shutoff valves, pressure gauges, drain ports, as required.
3. If the station is to include an automated process for keeping the Primary Tank filled, add the following components:
  - a. One Secondary Tank (H), typically a 55-gallon fluid drum, that can be manually refilled or replaced as needed.
  - b. One Pneumatic Remote Transfer Fill Pump (N), used to move fluid from the Secondary Tank to the Primary Tank.
  - c. One electric or pneumatic agitator (R), properly sized to fit the Secondary Tank and used to mix the fluid.
  - d. One Radar Level Sensor (M), used to monitor the fluid level in the Secondary Tank.
  - e. One Fill Pump Transfer Solenoid (P), used to turn the pneumatic remote transfer pump on and off as needed.
  - f. One Tank Control Module (TD), used to provide power and communication connection to the Secondary Tank components.

4. Determine the type and number of paint kitchen components to be installed in the non-hazardous location, needed to control the number of stations:
  - a. One Touchscreen Box (J), if used.

**NOTE:** Remember that it is possible for an Intelligent Paint Kitchen system to use both a Touchscreen Box and a PLC or network connection for additional control and component visibility.
  - b. One Supervisor Box (A) to control the first 10 stations.
  - c. One Expansion Box, if the system contains more stations than can be connected to the Supervisor Box.
  - d. More Supervisor Boxes and Expansion Boxes, if needed to accommodate up to 20 stations in the Intelligent Paint Kitchen system. See [Scaling Up the System, page 152](#).
  - e. One DC Power Supply with Barrier (S), to provide power to the Tank Control Module (when used) in each station.
  - f. One Variable Frequency Drive/Inverter (B) to individually control each Radar Level Sensor (M) in the system.
5. Determine the type, length, and number of cables needed to connect the paint kitchen components together:
  - a. Power cables
  - b. Fiber optic cables
  - c. Ethernet cables
  - d. CAN communication cables
  - e. RS-485 twisted two-wire communication cables

**NOTE:** For a detailed list of available cables, see [Appendix B: Cables, page 153](#).

## Scaling Up the System

Every Intelligent Paint Kitchen system has at least one Supervisor Box containing at least one fiber optic converter. As more stations are added to the system, Expansion Boxes and Supervisor Boxes may be required.

One Supervisor Box can hold up to 10 fiber optic converters. Each fiber optic converter represents a connection to exactly one station. If your system has more than 10 stations, add an Expansion Box as shown below.

An Intelligent Paint Kitchen with one Supervisor Box and one Expansion Box can accommodate a maximum of 20 fiber optic converters, controlling up to 20 stations.

**NOTE:** One Supervisor Box can hold up to 10 fiber optic converters, and one Expansion Box can hold up to 12 fiber optic converters, making a total of 22 fiber optic converters. However, only 20 connections can actually be made from one Supervisor Box/Expansion Box pair to the stations.

Number of Stations	Required Number of Supervisor Boxes	Required Number of Expansion Boxes
1-10	One Supervisor Box	—
11-20	One Supervisor Box	One Expansion Box

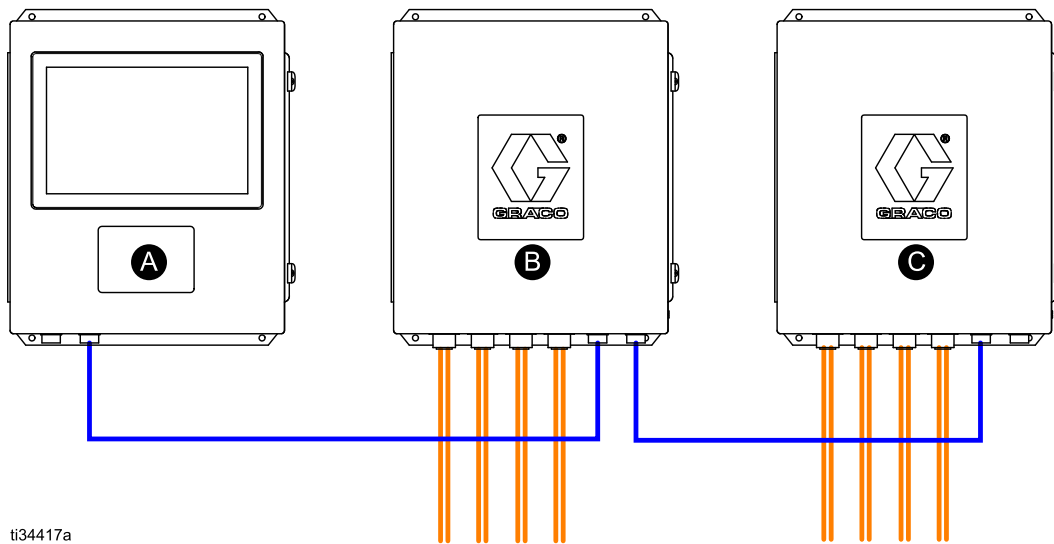

ti34417a

Figure 103 Intelligent Paint Kitchen System with Supervisor Box and Expansion Box



## Appendix B: Cables

The following cables are typically used to connect the components in an Intelligent Paint Kitchen system.

Cable Type	Length	Part No.	Use
Ethernet Cable	1 foot (0.3 m)	121994	<ol style="list-style-type: none"> <li>Use to connect the Touchscreen Box (J) to the Supervisor Box (A).</li> <li>Use to connect multiple Supervisor Boxes together.</li> </ol>
	25 feet (8 m)	121998	
	50 feet (16 m)	121999	
	100 feet (30 m)	15V842	
	200 feet (60 m)	15V843	
RS-485 Communication (Twisted Two-Wire Shielded Cable)	50 feet (16 m)	121700	<ol style="list-style-type: none"> <li>Use for Variable Frequency Drive/Inverter (B) communication.</li> <li>Use to connect each Expansion Box to a Supervisor Box.</li> <li>Use to connect each Variable Frequency Drive/Inverter to a Supervisor Box.</li> </ol>
	500 feet (152 m)	115769	
	1000 feet (305 m)	115770	
IS CAN Cable (Female-Female)	3 feet (1 m)	16P911	Use to connect a Pump Control Module (PD) to a pump.
	25 feet (8 m)	16P912	
Fiber Optic Cable	10 feet (3 m)	17T898	<ol style="list-style-type: none"> <li>Use to connect each Pump Control Module to a fiber optic converter inside the Supervisor Box.</li> <li>Use to connect a Tank Control Module (TD) to a Pump Control Module.</li> </ol>
	50 feet (16 m)	16M172	
	100 feet (30 m)	16M173	
	330 feet (100 m)	17B160	
I/O Cable	25 feet (8 m)	16Y911	Use to connect a Back Pressure Regulator Controller (F) or Radar Level Sensor (M, T) to the pump or Tank Control Module. NOTE: This cable comes installed from the factory on the Back Pressure Regulator Controller and Radar Level Sensor.
IS Power Cable	52 feet (16 m)	16K509	Use to connect each Tank Control Module to the DC Power Supply with Barrier (S) installed in the non-hazardous location.
	105 feet (32 m)	16K615	

*Appendix B: Cables*

<b>Cable Type</b>	<b>Length</b>	<b>Part No.</b>	<b>Use</b>
Power Transducer Extension	6 feet (2 m)	16V103	Use to extend cable length of pressure transducers.
	50 feet (16 m)	16V381	

# Appendix C: Electrical Schematics

## Touchscreen Box Schematic

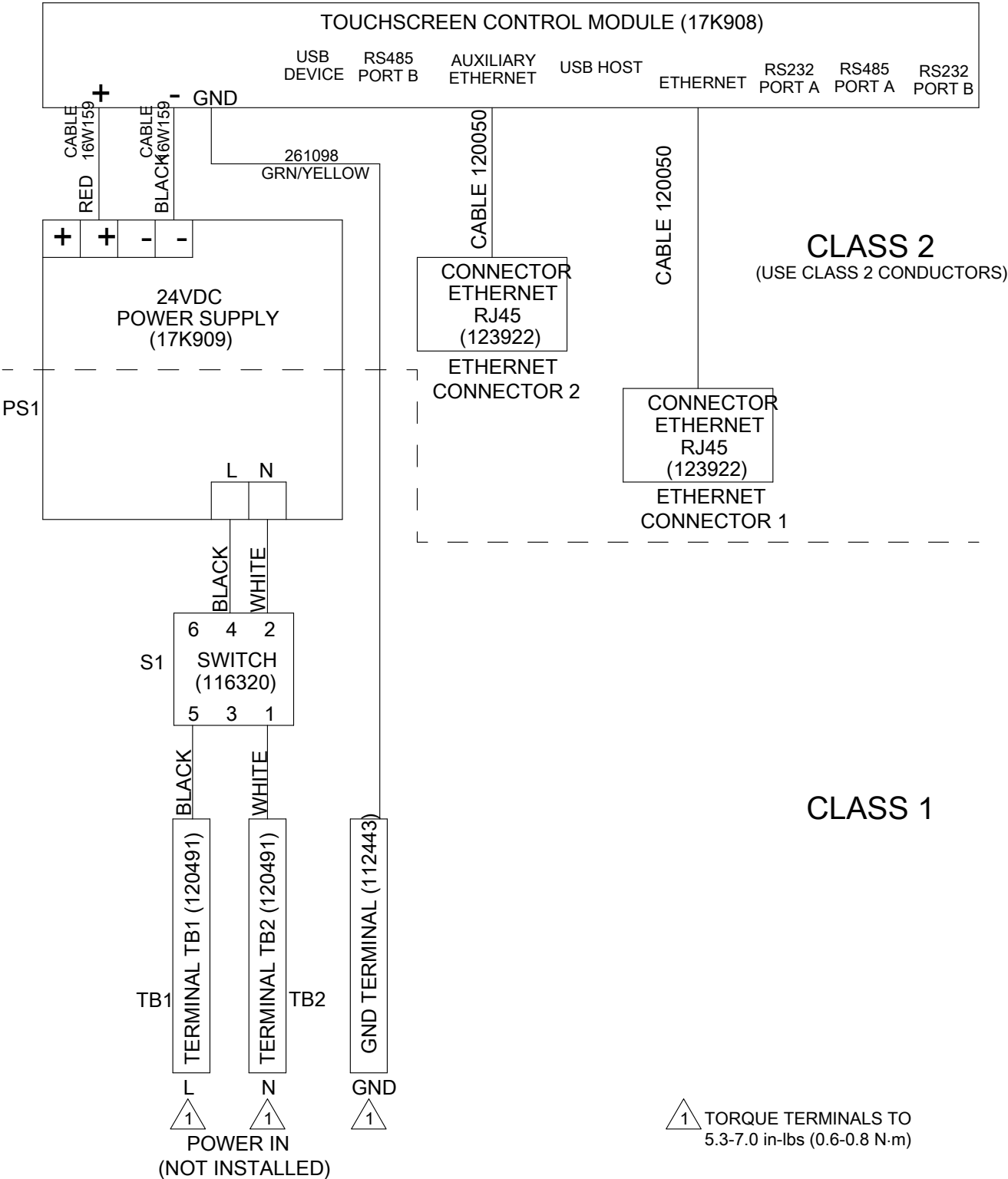

Figure 104 Touchscreen Box Schematic

### Supervisor Box Schematic

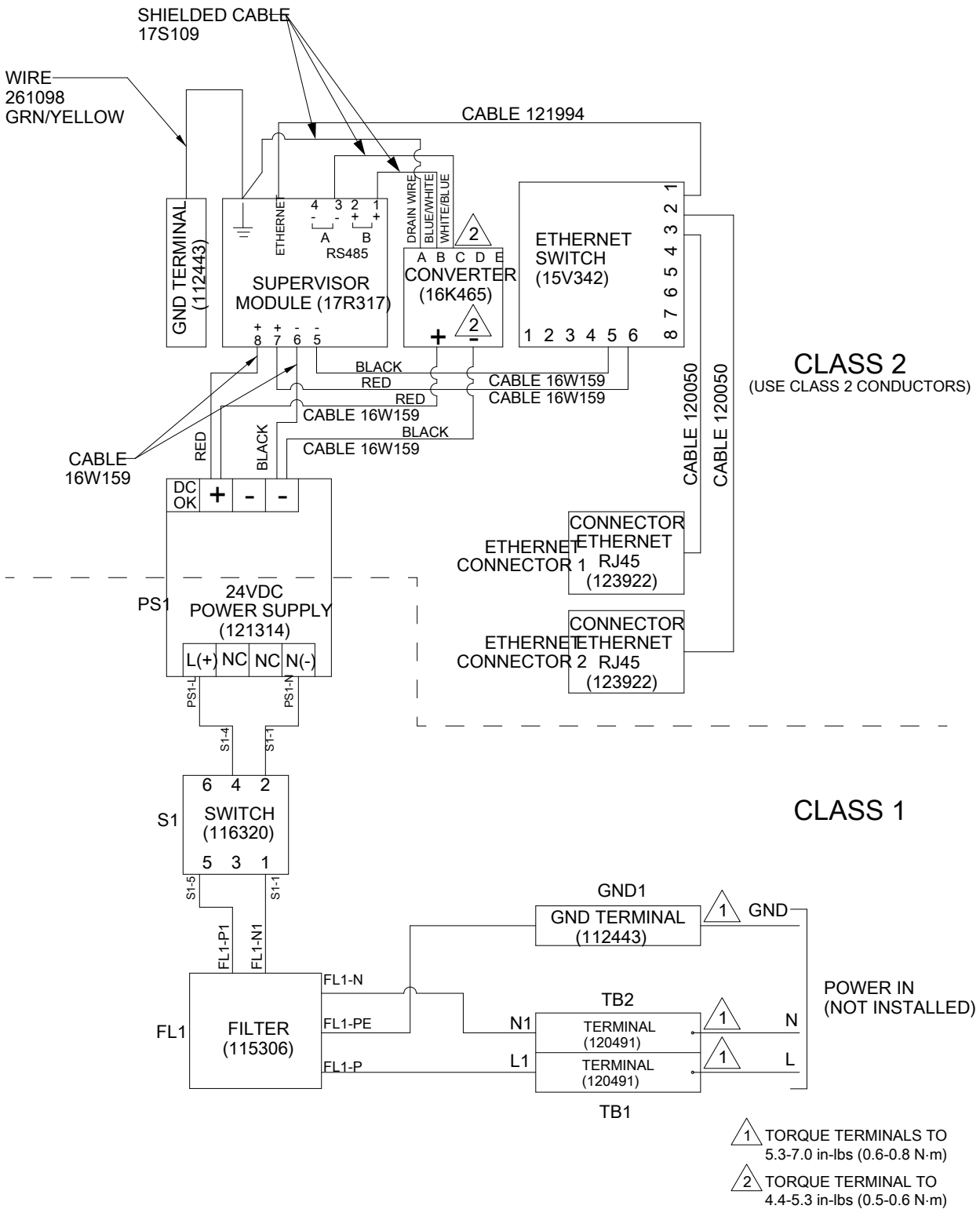

Figure 105 Supervisor Box Schematic

**Expansion Box Schematic**

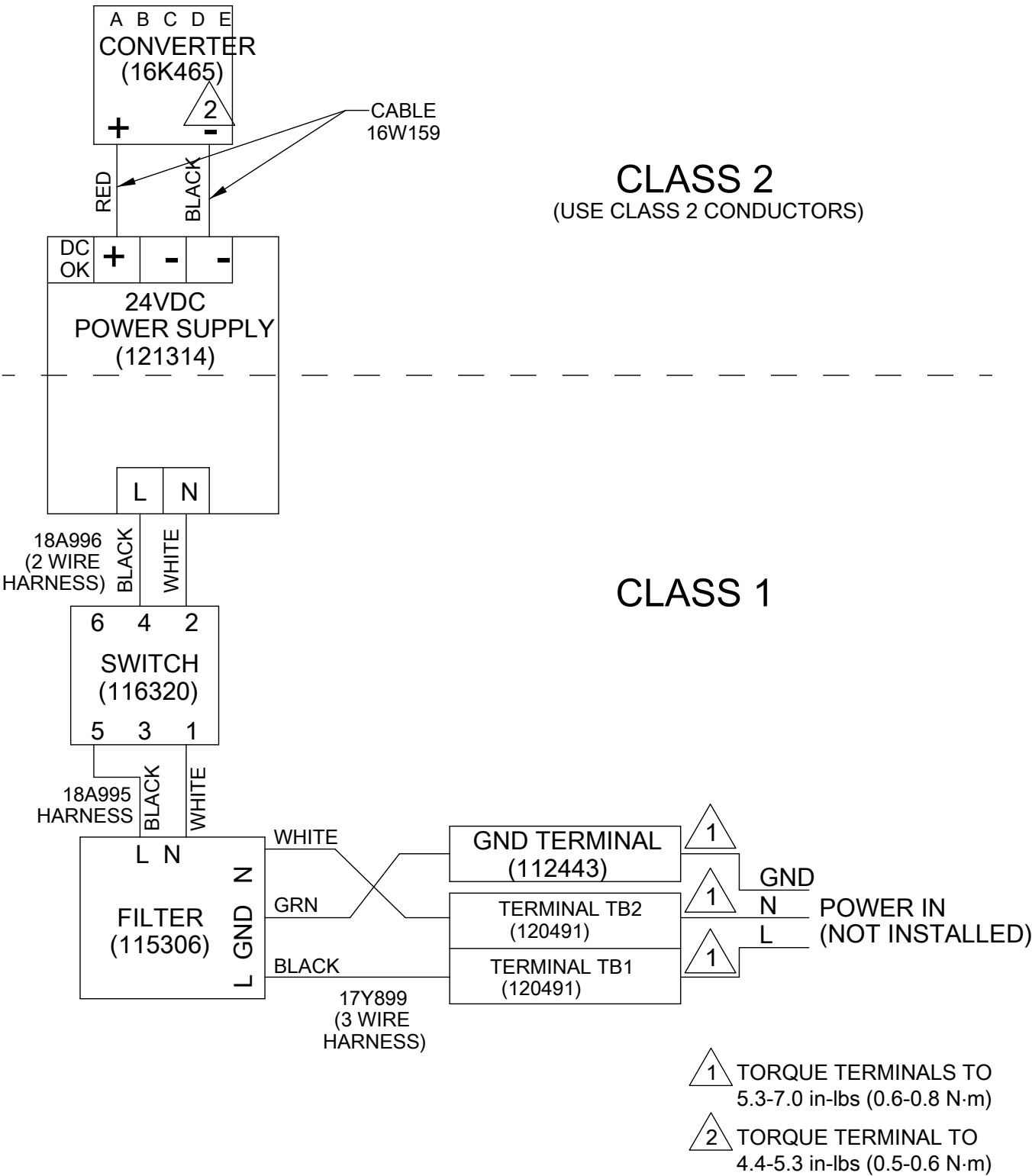

Figure 106 Expansion Box Schematic

# Appendix D: Communication Configuration

When installing a system, each component requires communication cables. See the diagram below for sample configurations.

**NOTE:** The last fiber optic converter in the system must have the RS-485 termination resistor installed on the uncabled connector to properly terminate the circuit. The termination resistor is installed on the fiber optic converter in the Supervisor Box in the factory. Relocate it if additional fiber optic converters are installed in the system.

## Allen Bradley PowerFlex

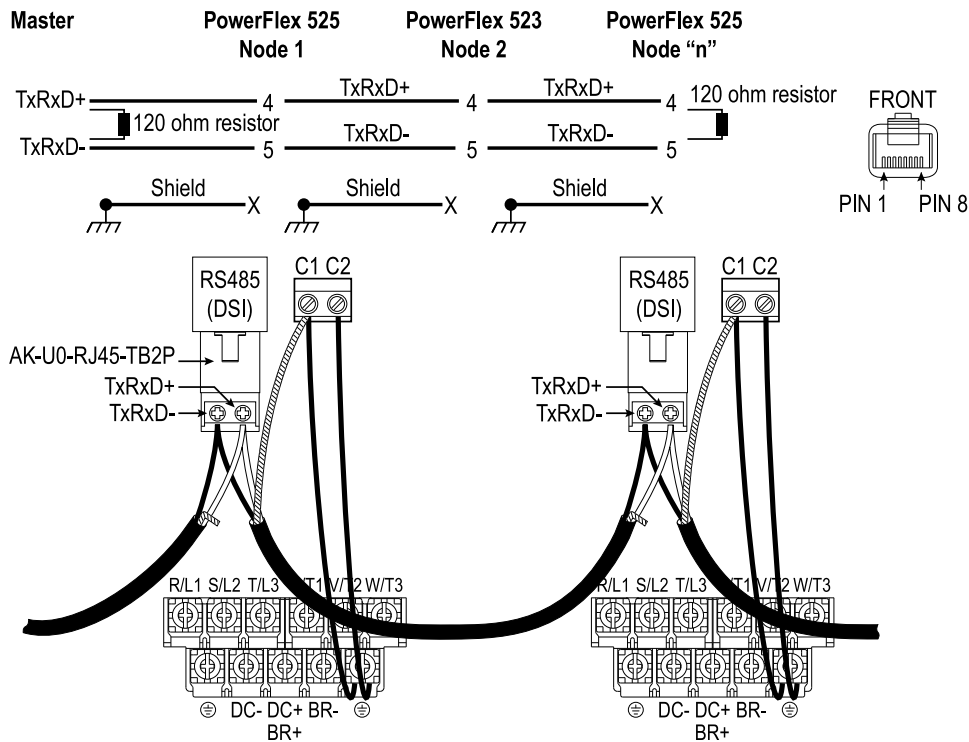

Figure 107 Modbus Wiring Diagram

TxRxD- = A(-)

TxRxD+ = B(+)

## Parameters

Parameter	Value	Description
P046	1 = Keypad 2 = DigInTrmBlk <b>3 = Serial/DSI</b> 4 = Network Opt 5 = EtherNet/IP	Start Source
P047	1 = Drive Pot 2 = Keypad Freq <b>3 = Serial/DSI</b> 4 = Network Opt 5 = 0-10V Input 6 = 4-20mA Input 7 = Preset Freq 8 = Anlg In Mult 9 = MOP 10 = Pulse Input 11 = PID1 Output 12 = PID2 Output 13 = Step Logic 14 = Encoder 15 = EtherNet/IP 16 = Positioning	Speed Source
C123	0 = 1200 1 = 2400 2 = 4800 3 = 9600 4 = 19200 <b>5 = 38400</b>	RS-485 Data Rate
C124	101-120 = Primary 121-140 = Secondary	RS-485 Node Address
C125	0 = Fault 1 = Coast Stop 2 = Stop 3 = Continu Last	Communication Loss Action

*Appendix D: Communication Configuration*

<b>Parameter</b>	<b>Value</b>	<b>Description</b>
C126	0.1 – 60 seconds	Communication Loss Time
C127	0 = RTU 8-N-1 1 = RTU 8-E-1 2 = RTU 8-O-1 <b>4 = RTU 8-N-2</b> 5 = RTU 8-E-2 6 = RTU 8-O-2	RS-485 Format



Mitsubishi

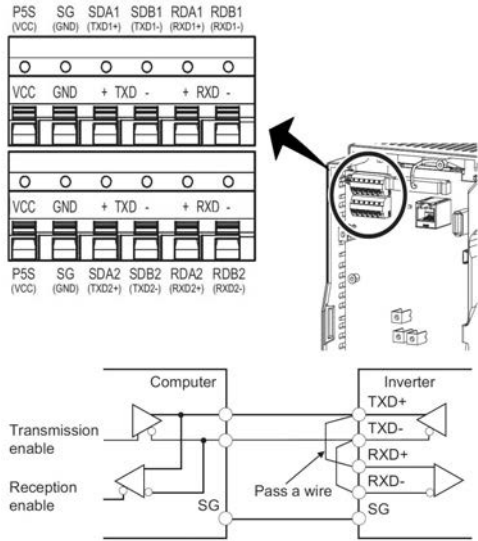

Figure 108 Wiring Diagram

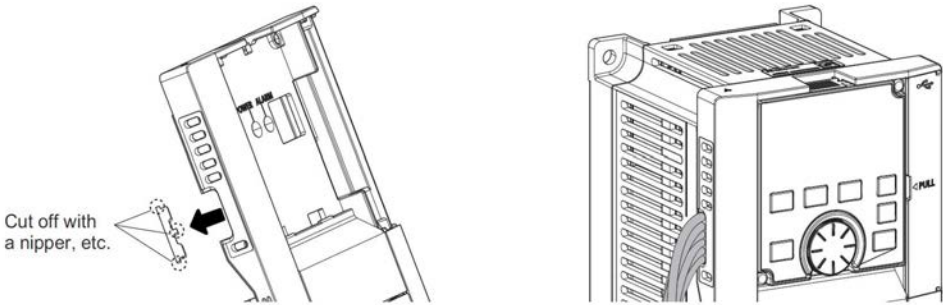

Figure 109 Wiring Routing

**Parameters**

Parameter	Description	Setting
P75	Reset Selection	14 = Reset command input always enabled.
P77	Parameter Write Selection	2 = Parameter writing is enabled in any operation mode regardless of operation status.
P79	Operation Mode Selection	2 = Fixed at External operation mode. However, the inverter operation mode can also be changed to the Network operation mode.
P331	RS-485 Communication Station Number	101–120 = Primary Agitator 121–140 = Secondary Agitator
P332	RS-485 Communication Baud Rate	576 = 57.6 K
P333	RS-485 Communication Config	1 = 8 Data Bits, 2 stop bits, no parity
P334	RS-485 Communication Parity	0 = None
P335	RS-485 Retry Count	1
P336	RS-485 Communication Check Time Interval	10
P338	Communication Operation Command Source	0 = Start command source is communication.
P339	Communication Speed Command Source	0 = Frequency command source is communication.
P340	Communication Startup Mode Selection	10 = The inverter starts up in the Network operation mode.  The operation mode can be changed between the PU operation mode and the Network operation mode from the operation panel. If an instantaneous power failure occurs when “12” is set, running is continued at the condition before the instantaneous power failure.
P549	Protocol Selection	1 = Modbus RTU
P550	NET mode operation command source selection	1 = The communication options is the command source when in the NET operation mode.
P551	PU mode operation command source selection	9999 = USB automatic recognition.  Normally, the PU connector is the command source. When the USB is connected, the USB connector is the command source.

## Appendix E: Node ID Assignments

Node ID numbers are generated as follows:

Node ID	Assignment
1–20	Pump control modules
51–70	Tank control modules
101–120	Primary agitators
121–140	Secondary agitators

## Appendix F: Agitator Part Numbers

### 60 Hz Direct Drive

Part No.	Description
25C453	3" Quick-clamp Flange Mount Agitator Motor
25C575	4" Quick-clamp Flange Mount Agitator Motor
25C454	7.5" OD flange Mount Agitator Motor (3" 150# ANSI Flange Mounting Holes)
25C462	Pressure Tank Agitator Assembly (5 Gallon)
25C470	Pressure Tank Agitator Assembly (10 Gallon)
25C471	Pressure Tank Agitator Assembly (15 Gallon)

### 60 Hz Back Gear

Part No.	Description
25C483	Back-Gear, Drive Only, with Ground Wire Kit
25C485	Back-Gear, Agitator
25C486	Back-Gear, Agitator with Siphon
25C374	Back-Gear, Agitator with Drum Cover and Elevator
25C451	Back-Gear, Agitator with Drum Cover, Elevator and Siphon

### 50 Hz Direct Drive

Part No.	Description
25C464	3" Quick-clamp Flange Mount Agitator Motor
25C576	4" Quick-clamp Flange Mount Agitator Motor
25C463	7.5" OD flange Mount Agitator Motor (3" 150# ANSI Flange Mounting Holes)
25C465	Pressure Tank Agitator Assembly (5 Gallon)
25C472	Pressure Tank Agitator Assembly (10 Gallon)
25C473	Pressure Tank Agitator Assembly (15 Gallon)

### 50 Hz Back Gear

Part No.	Description
25C484	Back-Gear, Drive Only, with Ground Wire Kit
25C487	Back-Gear, Agitator
25C488	Back-Gear, Agitator with Siphon
25C481	Back-Gear, Agitator with Drum Cover and Elevator
25C480	Back-Gear, Agitator with Drum Cover, Elevator and Siphon

# Appendix G: Update the Intelligent Paint Kitchen Software

The Intelligent Paint Kitchen software can be updated when a new version is available from Graco. A USB A to USB B cable is needed for this procedure.

1. Download the new software onto your computer.
2. Connect the A to B USB cable to your computer, and to the USB Device Port (DP) on the bottom of the Touchscreen Module (14).

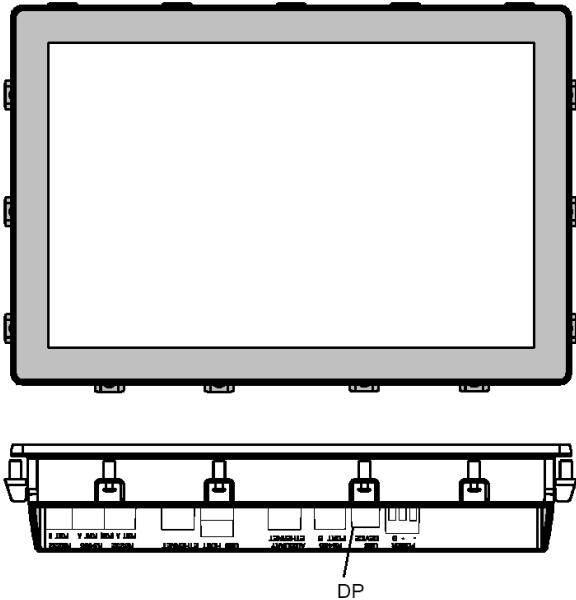

Figure 110 USB Connection on the Bottom of the Touchscreen Module

When connected, the Intelligent Paint Kitchen system displays as a Removable Disk on your computer.

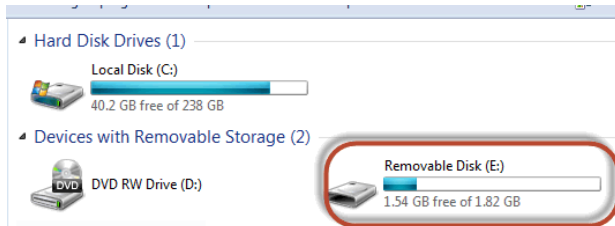

Figure 111 Removable Disk

3. Double click to open the removable disk.
4. Replace the **image.ci3** file with the updated file.

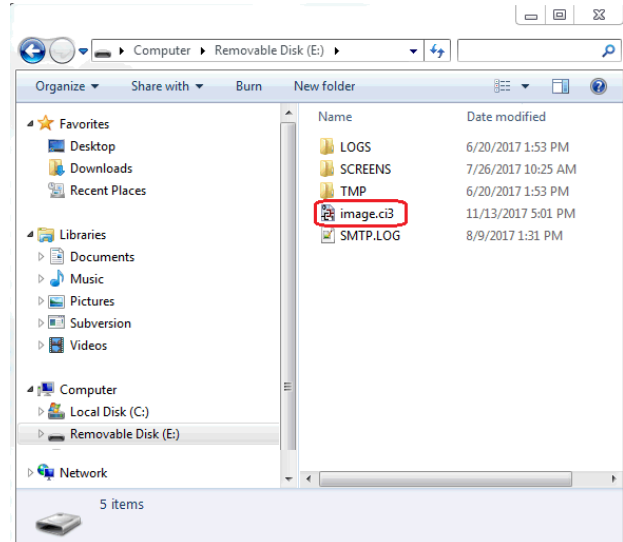

Figure 112 Replacing the image.ci3 File

NOTE: If no removable disk displays after connecting the A to B USB cable, install the updated software using an SD card. See [Use an SD Card](#), page 138.

## Appendix H: Master/Client Setup

The intelligent paint kitchen offers a two screen solution where the user can view information from displays at two different locations. When using this feature, only one display can be in control of the system. While the Master display has full control, the Client display can only display information or submit requests to become the Master display.

In order to use this feature, the two displays must have unique Port 2 IP addresses on the network. The IP addresses are assigned independently from each display. (See [Network Setup and Configuration, page 94.](#))

- The default Master display should have a Port 2 IP address of “192.168.1.50”.

**Note**

The display with this IP address is always recognized as the Master if both displays are detected during power up.

- The default Client display should have a Port 2 IP address of “192.168.1.51”.

**Note**

The display with this IP address is always recognized as the Client if both displays are detected during power up. If the default Master is not detected during power up, the default Client display will automatically become the Master.

## Configure Multiple Displays

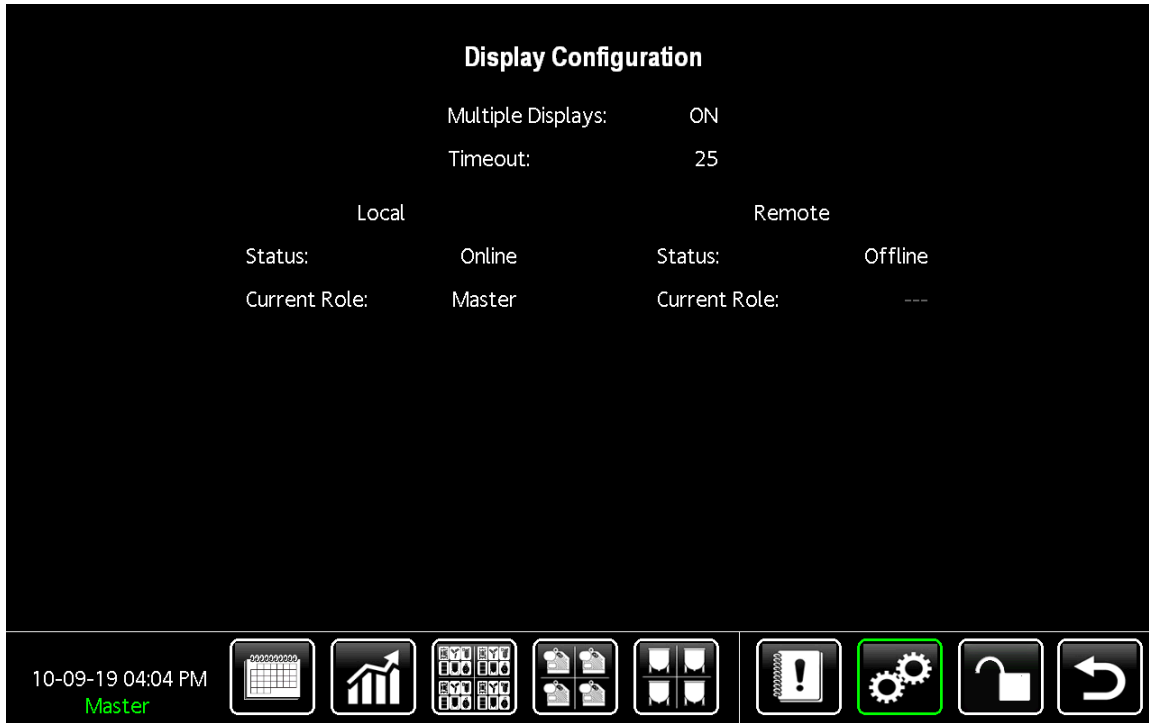

Figure 113 Multiple Display Configuration Screen

1. Press  on any Run screen to enter the Setup menu screen.
2. Press **HMI Configuration**.
3. Press **Multiple Displays**.
4. Press each field to enter or select configuration settings. For a list of fields, see [Fields on the Multiple Display Configuration Screen](#).

Table 14 Fields on the Multiple Display Configuration Screen

Item	Description
Multiple Displays	Select <b>ON</b> to enable the Master/Client feature. Select <b>OFF</b> to disable the Master/Client feature.
Timeout	Specify the number of seconds the Client display will wait before taking control as the Master display. When the Client display sends a request, the Master display has a specified amount of time to reject the request before the Client display will take control and become the Master.
Local Status	Displays the current status of the local display as Online or Offline.
Local Current Role	Displays the current status of the local display as Master or Client.
Remote Status	Displays the current status of the remote display as Online or Offline.
Remote Current Role	Displays the current status of the remote display as Master or Client.

### At Power Up

During power up, the HMIs will try to establish communication. If one of the HMIs can't be detected, the other HMI will establish itself as the Master. In the case that the default Client HMI doesn't detect the Master HMI, it will make itself "Master"; and when the default Master HMI eventually comes online, it will automatically request to become "Master".

### During Normal Operation

The current role of the display is always reported in the bottom left corner of the display. The following screen shot is an example of a Master display.

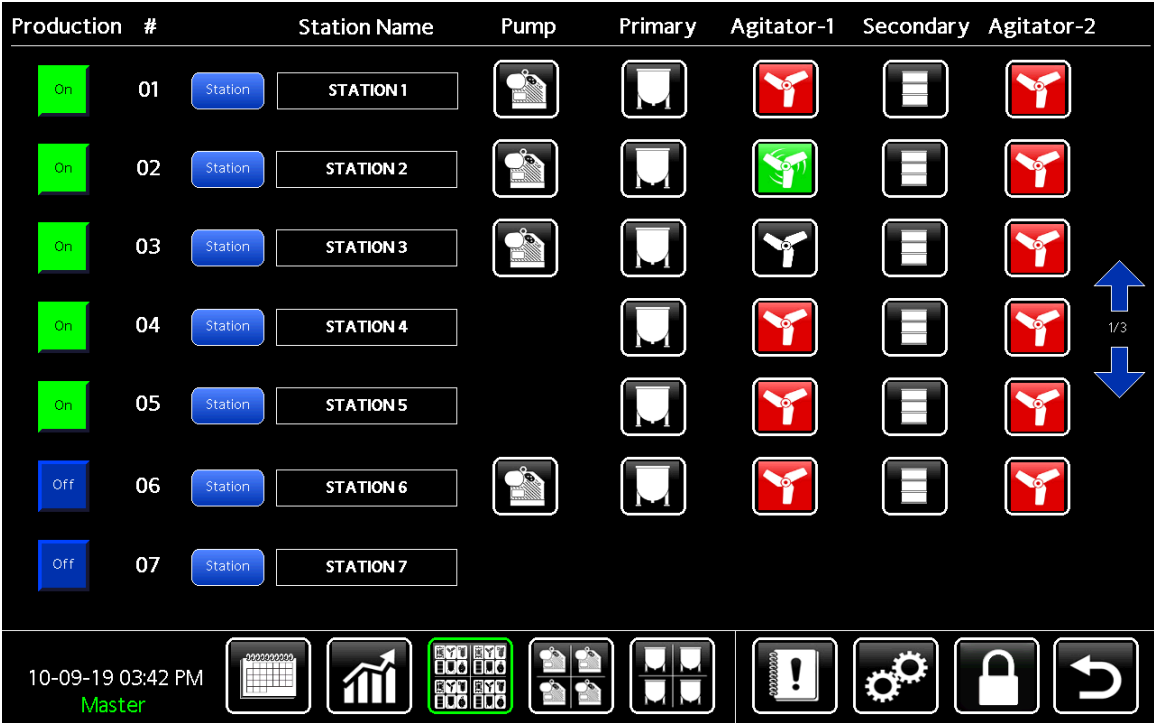
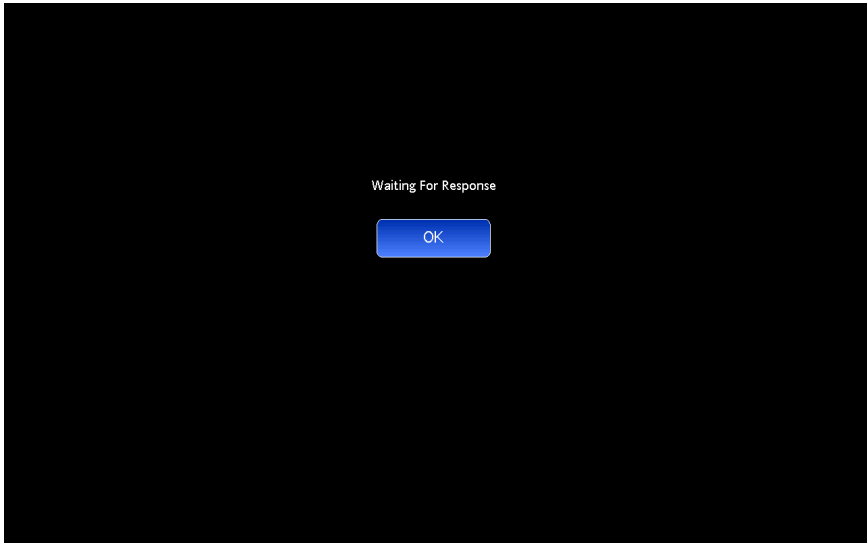
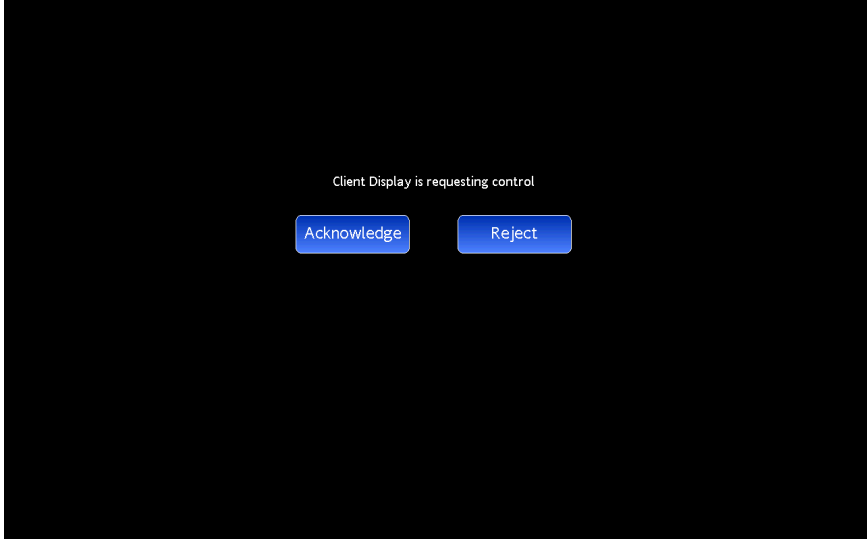

Figure 114 Example of a Master Display

*Appendix H: Master/Client Setup*

If the local display shows a role of “Client”, the user can press on “Client” to send a request to the Master to gain control. The following messages appear simultaneously on the local and remote HMIs.

<p><b>Local HMI</b> “Waiting for Response”</p>	 <p>Waiting For Response</p> <p>OK</p>
<p><b>Remote HMI</b> “Client Display is requesting control”</p>	 <p>Client Display is requesting control</p> <p>Acknowledge Reject</p>

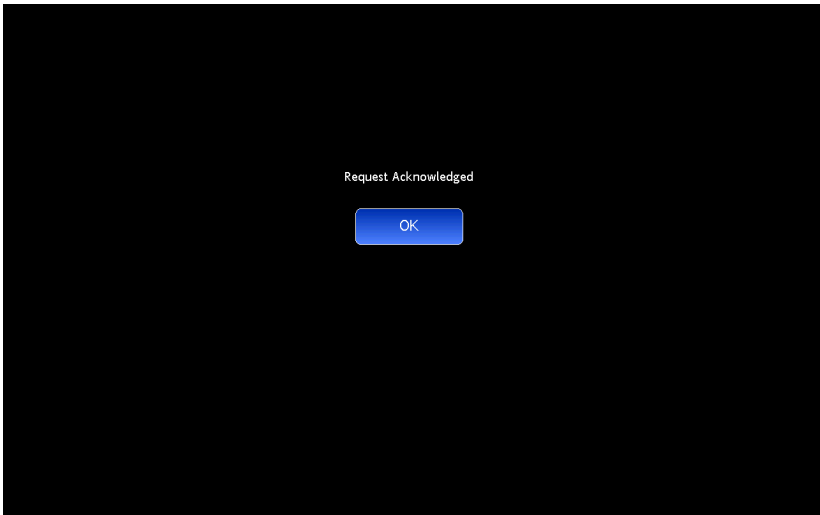
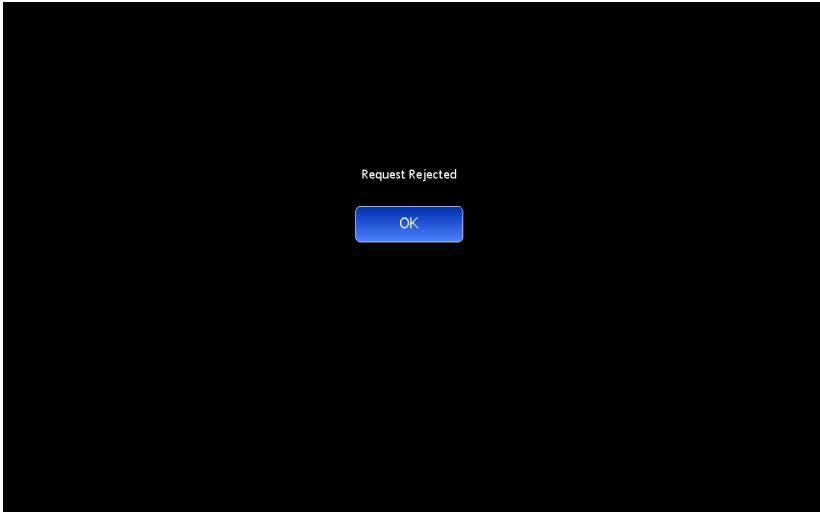
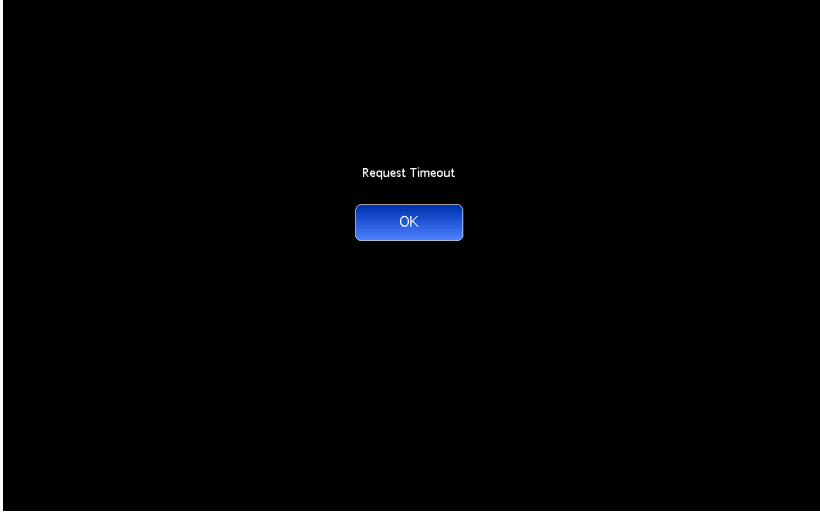

The following messages will appear on the local HMI depending on action from the remote HMI:

Remote HMI Action	Local HMI Message
<p><b>“Request Acknowledged”</b></p> <p>The remote HMI user acknowledged the request; the local HMI becomes the Master and the remote HMI becomes the Client.</p>	 <p>The screenshot shows a black background with the text "Request Acknowledged" centered at the top. Below the text is a blue rectangular button with the text "OK" in white.</p>
<p><b>“Request Rejected”</b></p> <p>The remote HMI user rejected the request and the roles remain unchanged.</p>	 <p>The screenshot shows a black background with the text "Request Rejected" centered at the top. Below the text is a blue rectangular button with the text "OK" in white.</p>
<p><b>“Request Timeout”</b></p> <p>The request was neither “Acknowledged” nor “Rejected” by remote HMI user, and the Timeout (see <a href="#">Configure Multiple Displays, page 166</a>) has expired. The local HMI becomes the Master and the remote HMI becomes the Client.</p>	 <p>The screenshot shows a black background with the text "Request Timeout" centered at the top. Below the text is a blue rectangular button with the text "OK" in white.</p>

# Appendix I: VEGAPULS 64 Tank Level Sensor Menu

## Setup

Menu Item	Setup
<b>Units</b>	<p>In this menu item you select the distance unit and the temperature unit. For distance units you can choose between m, in, and ft; and for temperature units °C, °F, and K.</p> <p><b>Default Values:</b></p> <p>Distance: m</p> <p>Temperature: °C</p>
<b>Application / Medium</b>	<p>You can choose between Solvents (oil, LPG), Chemical mixtures, and Water based.</p> <p><b>Default Values:</b></p> <p>Medium: Water Solution</p>
<b>Application / Application / Storage Tank</b>	<p><b>Storage Tank</b></p> <ul style="list-style-type: none"> <li>• Vessel <ul style="list-style-type: none"> <li>– Large Volume</li> <li>– Upright cylindrical, horizontal round</li> </ul> </li> <li>• Process/measurement conditions: <ul style="list-style-type: none"> <li>– Condensation</li> <li>– Smooth medium surface</li> <li>– High requirements on measurement accuracy</li> <li>– Slow filling and emptying</li> </ul> </li> <li>• Properties, sensor: <ul style="list-style-type: none"> <li>– Low sensitivity to sporadic false echoes</li> <li>– Stable and reliable measured values through averaging</li> <li>– High measurement accuracy</li> <li>– No short reaction time of the sensor required</li> </ul> </li> </ul>

Menu Item	Setup
<p><b>Application / Application / Storage tank with product circulation</b></p>	<p><b>Storage tank with product circulation</b></p> <ul style="list-style-type: none"> <li>• Setup: large-volumed, upright cylindrical, spherical</li> <li>• Medium speed: show filling and emptying</li> <li>• Installations: small, laterally mounted or large, top mounted stirrer</li> <li>• Process/measurement conditions:               <ul style="list-style-type: none"> <li>– Relatively smooth medium surface</li> <li>– High requirements on measurement accuracy</li> <li>– Condensation</li> <li>– Slight foam generation</li> <li>– Overfilling possible</li> </ul> </li> <li>• Properties, sensor:               <ul style="list-style-type: none"> <li>– Low sensitivity to sporadic false echoes</li> <li>– Stable and reliable measured values through averaging</li> <li>– High measurement accuracy, because not set for max. speed</li> <li>– False signal suppression recommended</li> </ul> </li> </ul>
<p><b>Application / Application / Storage tank on ships (Cargo Tank)</b></p>	<p><b>Storage tank on ships (Cargo Tank)</b></p> <ul style="list-style-type: none"> <li>• Medium speed: slow filling, emptying</li> <li>• Vessel:               <ul style="list-style-type: none"> <li>– Installations in the bottom section (bracers, heating spirals)</li> <li>– High sockets 200 ... 500 mm, also with large diameters</li> </ul> </li> <li>• Process/measurement conditions:               <ul style="list-style-type: none"> <li>– Condensation, buildup by movement</li> <li>– Max. requirement on measurement accuracy from 95%</li> </ul> </li> <li>• Properties, sensor:               <ul style="list-style-type: none"> <li>– Low sensitivity to sporadic false echoes</li> <li>– Stable and reliable measured values through averaging</li> <li>– High measurement accuracy</li> <li>– False signal suppression required</li> </ul> </li> </ul>

Menu Item	Setup
<b>Application / Application / Stirrer Vessel (reactor)</b>	<b>Stirrer vessel (reactor)</b> <ul style="list-style-type: none"> <li>• Vessel:                             <ul style="list-style-type: none"> <li>– Mounting socket</li> <li>– Large agitator blades of metal</li> <li>– Vortex breakers, heating spirals</li> </ul> </li> <li>• Process/measurement conditions:                             <ul style="list-style-type: none"> <li>– Condensation, buildup by movement</li> <li>– Strong vortex generation</li> <li>– Very agitated surface, foam generation</li> <li>– Fast to slow filling and emptying</li> <li>– Vessel is filled and emptied very often</li> </ul> </li> <li>• Properties, sensor:                             <ul style="list-style-type: none"> <li>– Higher measurement speed through less averaging</li> <li>– Sporadic false echoes are suppressed</li> </ul> </li> </ul>
<b>Application / Application / Dosing Vessel</b>	<b>Dosing vessel</b> <ul style="list-style-type: none"> <li>• Setup: all vessel sizes possible</li> <li>• Medium speed:                             <ul style="list-style-type: none"> <li>– Fast filling and emptying</li> <li>– Vessel is filled and emptied very often</li> </ul> </li> <li>• Vessel: tight installation situation</li> <li>• Process/measurement conditions:                             <ul style="list-style-type: none"> <li>– Condensation, buildup on the antenna</li> <li>– Foam generation</li> </ul> </li> <li>• Properties, sensor:                             <ul style="list-style-type: none"> <li>– Measurement speed optimized by virtually no averaging</li> <li>– Sporadic false echoes are suppressed</li> <li>– False signal suppression recommended</li> </ul> </li> </ul>
<b>Application / Application / Plastic tank</b>	<b>Plastic tank</b> <ul style="list-style-type: none"> <li>• Process/measurement conditions:                             <ul style="list-style-type: none"> <li>– Condensation on the plastic ceiling</li> <li>– In outdoor facilities, water and snow on vessel top possible</li> <li>– Measurement through the vessel top, if appropriate to the application</li> </ul> </li> <li>• Properties, sensor:                             <ul style="list-style-type: none"> <li>– False signals outside the vessel are not taken into consideration</li> <li>– False signal suppression recommended</li> </ul> </li> </ul>

Menu Item	Setup
<b>Application / Application / Transportable Plastic tank</b>	<b>Transportable plastic tank</b> <ul style="list-style-type: none"> <li>• Process/measurement conditions:                             <ul style="list-style-type: none"> <li>– Material and thickness different</li> <li>– Measured value jump with vessel change</li> <li>– Measurement through the vessel top, if appropriate to the application</li> </ul> </li> <li>• Properties, sensor:                             <ul style="list-style-type: none"> <li>– Quick adaptation to changing reflection conditions due to vessel change required</li> <li>– False signal suppression required</li> </ul> </li> </ul>
<b>Application / Application / Open water (gauge measurement)</b>	<b>Open water (gauge measurement)</b> <ul style="list-style-type: none"> <li>• Process/measurement conditions:                             <ul style="list-style-type: none"> <li>– Slow gauge change</li> <li>– Extreme damping of output signal due to wave generation</li> <li>– Ice and condensation on the antenna possible</li> <li>– Floating debris sporadically on the water surface</li> </ul> </li> <li>• Properties, sensor:                             <ul style="list-style-type: none"> <li>– Stable and reliable measured values through frequent averaging</li> <li>– Insensitive in the close range</li> </ul> </li> </ul>
<b>Application / Application / Open flume (flow measurement)</b>	<b>Open flume (flow measurement)</b> <ul style="list-style-type: none"> <li>• Process/measurement conditions:                             <ul style="list-style-type: none"> <li>– Slow gauge change</li> <li>– Ice and condensation on the antenna possible</li> <li>– Smooth water surface</li> <li>– Exact measurement result required</li> </ul> </li> <li>• Properties, sensor:                             <ul style="list-style-type: none"> <li>– Stable and reliable measured values through frequent averaging</li> <li>– Insensitive in the close range</li> </ul> </li> </ul>
<b>Application / Application / Rain water spillover (weir)</b>	<b>Rain water spillover (weir)</b> <ul style="list-style-type: none"> <li>• Rate of level change: slow level change</li> <li>• Process/measurement conditions:                             <ul style="list-style-type: none"> <li>– Ice and condensation on the antenna possible</li> <li>– Spiders and insects build nests in the antennas</li> <li>– Turbulent water surface</li> <li>– Sensor flooding possible</li> </ul> </li> <li>• Properties, sensors:                             <ul style="list-style-type: none"> <li>– Stable and reliable measured values through frequent averaging</li> <li>– Insensitive in the close range</li> </ul> </li> </ul>

Menu Item	Setup
<b>Application / Application / Demonstration</b>	<b>Demonstration</b> <ul style="list-style-type: none"> <li>• Adjustment for all applications which are not typically level measurement                             <ul style="list-style-type: none"> <li>– Instrument demonstration</li> <li>– Object recognition/monitoring (additional settings required)</li> </ul> </li> <li>• Properties, sensor:                             <ul style="list-style-type: none"> <li>– Sensor accepts all measured value changes within the measuring range immediately</li> <li>– High sensitivity to interference, because virtually no averaging</li> </ul> </li> </ul>
<b>Application / Application / Vessel form</b>	<b>Vessel form</b> <p>Apart from the medium and the application, the vessel form itself can influence the measurement. To adapt the sensor to these measuring conditions, this menu item offers different options for vessel bottom and ceiling for certain applications.</p> <p>Enter the requested parameters via the appropriate keys, save your settings with OK and jump to the next item with ESC and the → key.</p>
<b>Application / Application / Vessel height/Measuring range</b>	<b>Vessel height/Measuring range</b> <p>Through this selection the operating range of the sensor is adapted to the vessel height, which considerably increases measurement reliability under different basic conditions.</p> <p>The min. adjustment must be carried out independently of this.</p> <p>Enter the requested parameters via the appropriate keys, save your settings with OK and jump to the next item with ESC and the → key.</p>

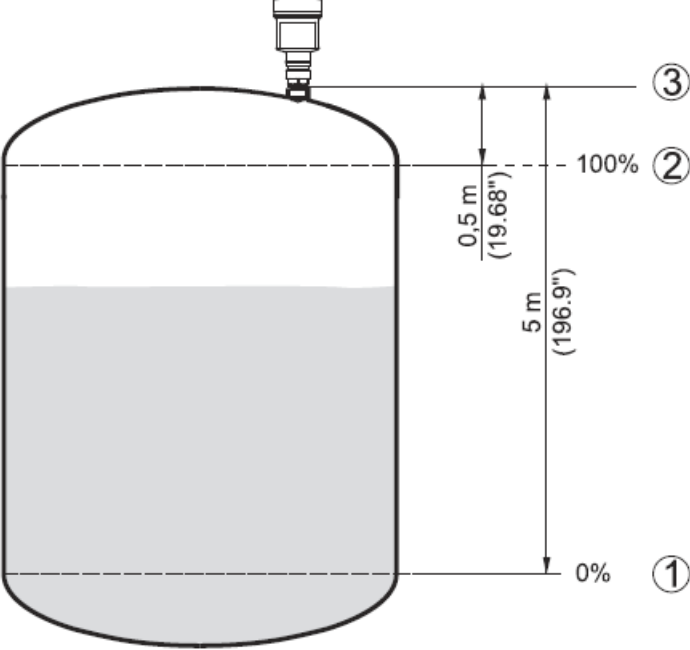
Menu Item	Setup
<p><b>Adjustment</b></p>	<p>Since the radar sensor is a distance measuring instrument, it is the distance from the sensor to the medium surface that is measured. To indicate the actual level, the measured distance must be assigned to a certain height percentage.</p> <p>To perform the adjustment, enter the distance with the full and empty vessel, see the following example:</p>  <ol style="list-style-type: none"> <li>1. Min. level = max. measuring distance</li> <li>2. Max. level = min. measuring distance</li> <li>3. Reference plane</li> </ol> <p>If these values are not known, an adjustment with the distances of e.g. 10% and 90% are possible. The starting point for these distance specifications is always the sealing surface of the thread or flange.</p> <p>The actual product level during this adjustment is not important, because the min./max. adjustment is always carried out without changing the product level. These settings can be made ahead of time without the instrument having to be installed.</p>
<p><b>Adjustment / Max. adjustment</b></p>	<p><b>Max. adjustment</b></p> <p>Proceed as follows:</p> <ol style="list-style-type: none"> <li>1. Select with the -&gt; key the menu item "Max. adjustment" and confirm with OK.</li> <li>2. Prepare the percentage value for editing with OK and set the cursor to the requested position with the -&gt; key.</li> <li>3. Set the requested percentage value with the + key and save with OK. The cursor jumps to the distance value.</li> <li>4. Enter the corresponding distance value in meters for the full vessel.</li> <li>5. Save settings with OK and move with ESC and the -&gt; to "Min. adjustment".</li> </ol>

Menu Item	Setup
<b>Adjustment / Min. adjustment</b>	<p><b>Min. adjustment</b></p> <p>Proceed as follows:</p> <ol style="list-style-type: none"> <li>1. Select with the -&gt; key the menu item "Min. adjustment" and confirm with OK.</li> <li>2. Prepare the percentage value for editing with OK and set the cursor to the requested position with the -&gt; key.</li> <li>3. Set the requested percentage value with the + key and save with OK. The cursor jumps to the distance value.</li> <li>4. Enter the suitable distance value in meters for the empty vessel (e.g. the distance from the sensor to the vessel bottom) corresponding to the percentage value.</li> </ol>
<b>Damping</b>	<p>To damp process-dependent measured value fluctuations, set an integration time of 0–999 seconds in this menu item.</p> <p>The default setting is 0 seconds.</p>
<b>Current Output</b>	<p><b>Current output mode</b></p> <p>You determine the output characteristics and reaction of the current output in case of fault.</p> <p>The default setting is output characteristics 4...20 mA, failure mode &lt;= 3.6 mA.</p> <p><b>Current output min./max.</b></p> <p>You determine the reaction of the current output during operation.</p> <p>The default setting is min. current 3.8 mA and max. current 20.5 mA.</p>

### Additional Adjustments

Menu Item	Setup
<b>Scaling</b>	<p>Define the scaling variable and the scaling format for the indication of the level measured value for 0% and 100% on the display.</p>
<b>Current Output</b>	<p><b>Current output variable</b></p> <p>Specify which measured variable the current output refers to.</p> <p><b>Current output, adjustment</b></p> <p>Assign a respective measured value to the current output.</p>



Menu Item	Setup
<p><b>False Signal Suppression</b></p>	<p>The following circumstances cause interfering reflections and can influence the measurement:</p> <ul style="list-style-type: none"> <li>• High mounting sockets</li> <li>• Vessel internals, such as struts</li> <li>• Agitators</li> <li>• Buildup or welded joints on vessel walls</li> </ul> <p><b>NOTE:</b> A false signal suppressions detects, marks, and saves these false signals to ensure that they are ignored in the level measurement.</p> <p>This should be done with the lowest possible level so that all potential interfering reflections can be detected.</p> <p>Proceed as follows:</p> <ol style="list-style-type: none"> <li>1. Select with the -&gt; key the menu item “False signal suppression” and confirm with OK.</li> <li>2. Confirm with OK three times and enter the actual distance from the sensor t the product surface.</li> <li>3. All interfering signals in this range are detected by the sensor and stored after being confirmed with OK.</li> </ol> <p><b>NOTE:</b> Check the distance to the product surface, because if an incorrect (too large) value is entered, the existing level will be saved as a false signal. The level would then no longer be detectable in this area.</p> <p>If false signal suppression has already been saved in the sensor, the a menu window appears with the following options:</p> <ul style="list-style-type: none"> <li>• <b>Delete:</b> An already created false signal suppression will be completely deleted. This is useful if the saved false signal suppression no longer matches the metrological conditions in the vessel.</li> <li>• <b>Extend:</b> Extends an already created false signal suppression. This is useful if a false signal suppression was carried out with too high a level and not all false signals could be detected. When selecting “Extend”, the distance to the product surface on the created false signal suppression is displayed. This value can now be changed and the false signal suppression can be extended to this range.</li> </ul>
<p><b>Linearization</b></p>	<p>Linearization is necessary for all vessels in which the vessel volume does not increase linearly with the level. corresponding linearization curves are preprogrammed for these vessels. They represent the correlation between the level percentage and vessel volume. The linearization applies to the measured value indication and the current output.</p>

# Appendix J: 25E861 - Expandable IO Module Kit

The expandable IO module kit offers the ability to integrate other paint kitchen IO that the user wants to log. The expansion IO module offers an additional 16 digital inputs. Inputs 0-7 are active low digital inputs, which mean the event will be triggered when the input

goes low. Inputs 8-15 are active high digital inputs, which mean the event will be triggered when the input goes high. The event names are configurable on the touch screen. The expandable IO module can only be used with systems that have a touch screen.

## Installation

1. Set up the IP Address.
  - a. Set rotary switches to the desired positions. The device needs the IP address of 192.168.1.100. The first three octets are set to 192.168.1.xxx. The last octet is set by the rotary switches. To set the last octet to 100, set the x100 switch to 1.

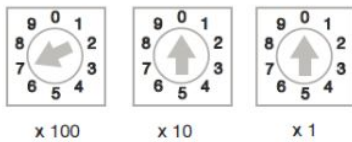

000: 192.168.1.254  
 1 - 254: static rotary  
 300: BootP  
 400: DHCP  
 500: PGM  
 600: PGM-DHCP  
 700: PROFINET

- b. Cycle (reset) the power to the station.
2. Connect the Ethernet cables to the Modbus TCP network. The Modbus TCP network is the network connected to the supervisor and touch screen.

3. Wire up the inputs.
  - a. Internal module electronics and the I/O channels 0 to 7 are supplied V1.
  - b. The I/O channels 8 to 13 are supplied via V2.
  - c. The I/O channels 14 and 15 are supplied via V3.
  - d. More devices can be supplied with 24 VDC, up to 0.7 A, via the terminals Vout1+ and Vout1.
  - e. Recommended torque for screw terminals: 4.43 in-lb (0.5 N•m).

### Terminal Connection

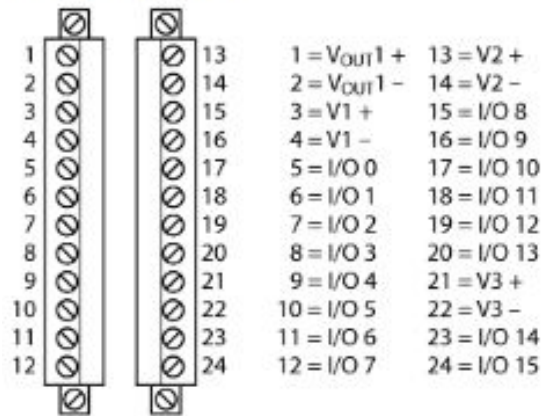

4. Enable the device on the touch screen setup screen.

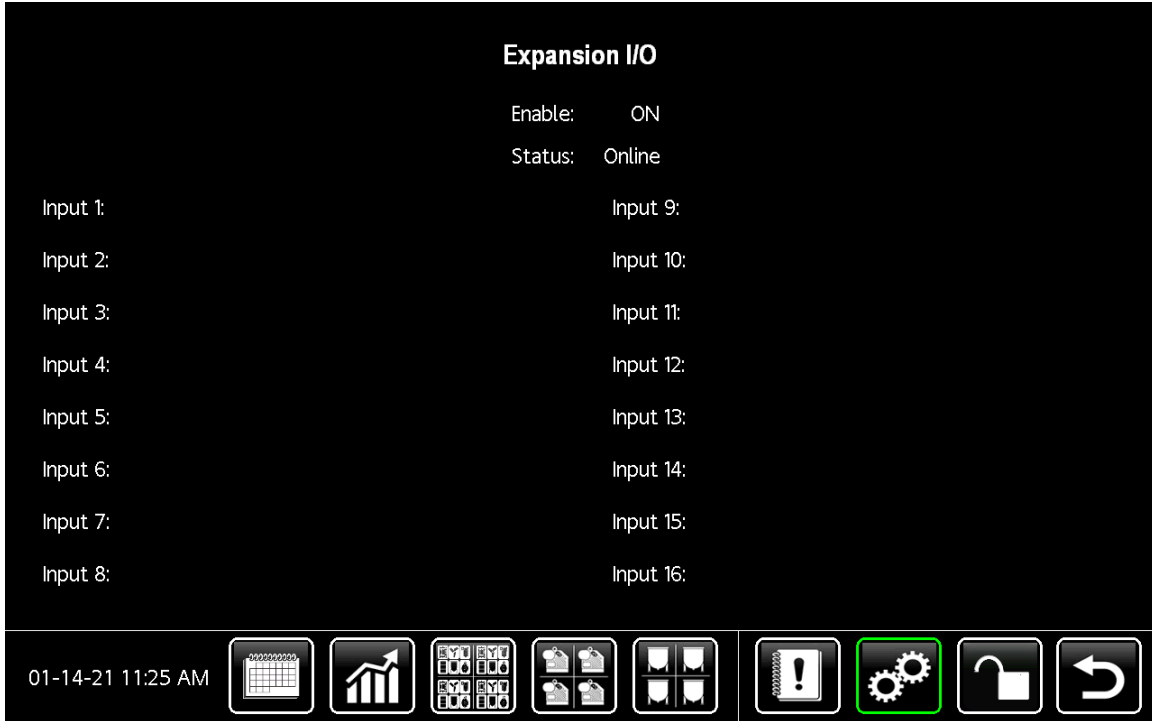

Figure 115 Expansion I/O Screen

## Troubleshooting

Table 15 Module LED Light Status

LED	Color	Status	Description
ETH1/E-TH2	Green	ON	Ethernet Link (100 Mbps)
		Flashing	Ethernet communication (100 Mbps)
	Yellow	ON	Ethernet Link (10 Mbps)
		Flashing	Ethernet communication (10 Mbps)
		OFF	No Ethernet link
BUS	Green	ON	Active connection to a master
		Flashing	Ready
	Red	ON	IP address conflict or status word is active
		Flashing	Blink/Wink command active
		OFF	Power off
ERR	Green	ON	Diagnostics disabled
	Red	ON	Short-circuit
I/O 0 – I/O 15	Green	ON	Input/Output: Active
		OFF	Input/Output: Inactive

# Graco Standard Warranty

Graco warrants all equipment referenced in this document which is manufactured by Graco and bearing its name to be free from defects in material and workmanship on the date of sale to the original purchaser for use. With the exception of any special, extended, or limited warranty published by Graco, Graco will, for a period of twelve months from the date of sale, repair or replace any part of the equipment determined by Graco to be defective. This warranty applies only when the equipment is installed, operated and maintained in accordance with Graco's written recommendations.

This warranty does not cover, and Graco shall not be liable for general wear and tear, or any malfunction, damage or wear caused by faulty installation, misapplication, abrasion, corrosion, inadequate or improper maintenance, negligence, accident, tampering, or substitution of non-Graco component parts. Nor shall Graco be liable for malfunction, damage or wear caused by the incompatibility of Graco equipment with structures, accessories, equipment or materials not supplied by Graco, or the improper design, manufacture, installation, operation or maintenance of structures, accessories, equipment or materials not supplied by Graco.

This warranty is conditioned upon the prepaid return of the equipment claimed to be defective to an authorized Graco distributor for verification of the claimed defect. If the claimed defect is verified, Graco will repair or replace free of charge any defective parts. The equipment will be returned to the original purchaser transportation prepaid. If inspection of the equipment does not disclose any defect in material or workmanship, repairs will be made at a reasonable charge, which charges may include the costs of parts, labor, and transportation.

**THIS WARRANTY IS EXCLUSIVE, AND IS IN LIEU OF ANY OTHER WARRANTIES, EXPRESS OR IMPLIED, INCLUDING BUT NOT LIMITED TO WARRANTY OF MERCHANTABILITY OR WARRANTY OF FITNESS FOR A PARTICULAR PURPOSE.**

Graco's sole obligation and buyer's sole remedy for any breach of warranty shall be as set forth above. The buyer agrees that no other remedy (including, but not limited to, incidental or consequential damages for lost profits, lost sales, injury to person or property, or any other incidental or consequential loss) shall be available. Any action for breach of warranty must be brought within two (2) years of the date of sale.

**GRACO MAKES NO WARRANTY, AND DISCLAIMS ALL IMPLIED WARRANTIES OF MERCHANTABILITY AND FITNESS FOR A PARTICULAR PURPOSE, IN CONNECTION WITH ACCESSORIES, EQUIPMENT, MATERIALS OR COMPONENTS SOLD BUT NOT MANUFACTURED BY GRACO.** These items sold, but not manufactured by Graco (such as electric motors, switches, hose, etc.), are subject to the warranty, if any, of their manufacturer. Graco will provide purchaser with reasonable assistance in making any claim for breach of these warranties.

In no event will Graco be liable for indirect, incidental, special or consequential damages resulting from Graco supplying equipment hereunder, or the furnishing, performance, or use of any products or other goods sold hereto, whether due to a breach of contract, breach of warranty, the negligence of Graco, or otherwise.

## FOR GRACO CANADA CUSTOMERS

The Parties acknowledge that they have required that the present document, as well as all documents, notices and legal proceedings entered into, given or instituted pursuant hereto or relating directly or indirectly hereto, be drawn up in English. Les parties reconnaissent avoir convenu que la rédaction du présente document sera en Anglais, ainsi que tous documents, avis et procédures judiciaires exécutés, donnés ou intentés, à la suite de ou en rapport, directement ou indirectement, avec les procédures concernées.

## Graco Information

For the latest information about Graco products, visit [www.graco.com](http://www.graco.com).

**To place an order**, contact your Graco Distributor or call to identify the nearest distributor.

**Phone:** 612-623-6921 **or Toll Free:** 1-800-328-0211 **Fax:** 612-378-3505

All written and visual data contained in this document reflects the latest product information available at the time of publication.

Graco reserves the right to make changes at any time without notice.

For patent information, see [www.graco.com/patents](http://www.graco.com/patents).

Original Instructions. This manual contains English. MM 3A4030

**Graco Headquarters:** Minneapolis

**International Offices:** Belgium, China, Japan, Korea

**GRACO INC. AND SUBSIDIARIES • P.O. BOX 1441 • MINNEAPOLIS MN 55440-1441 • USA**

**Copyright 2019, Graco Inc. All Graco manufacturing locations are registered to ISO 9001.**

[www.graco.com](http://www.graco.com)

Revision G, January 2023