

# SaniForce™ 12:1 Sanitary Pumps

3A0735P  
EN

**For use in sanitary applications to transfer medium to high viscosity fluids.  
For professional use only.**

*See page 2 for model information, including maximum fluid working pressure.*



### **Important Safety Instructions**

Read all warnings and instructions in this manual. Save these instructions.

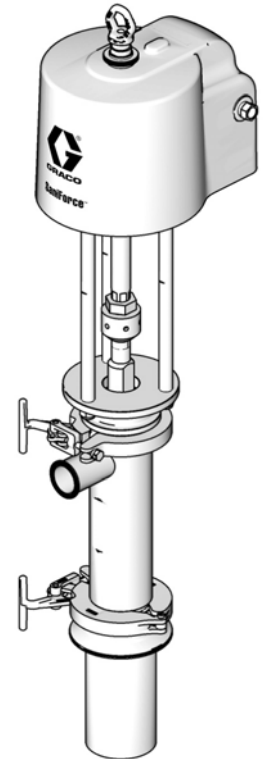

ti15718a

# Contents

<b>Models</b> .....	<b>2</b>	<b>Service</b> .....	<b>11</b>
<b>Warnings</b> .....	<b>4</b>	Disconnect the Pump .....	11
<b>Installation</b> .....	<b>6</b>	Disassemble the Pump .....	11
Grounding .....	6	Reassemble the Pump .....	13
Mounting .....	6	Reconnect the Pump .....	14
Setup .....	6	<b>Parts</b> .....	<b>16</b>
<b>Operation</b> .....	<b>8</b>	Complete Pump Models 24F625	
Pressure Relief Procedure .....	8	and 24F626 .....	16
Flush Before First Use .....	8	Kits .....	17
Adjusting the Pump Speed and Pressure .....	8	Displacement Pump Models 24G761	
Pump Shutdown .....	8	and 24G762 .....	18
<b>Maintenance</b> .....	<b>9</b>	Displacement Pump Models 24G761	
Flushing Procedure .....	9	and 24G762 .....	19
Cleaning Procedure .....	9	Kits .....	19
Tighten Connections .....	9	<b>Dimensions</b> .....	<b>21</b>
<b>Troubleshooting</b> .....	<b>10</b>	<b>Performance Chart</b> .....	<b>22</b>
		<b>Technical Data</b> .....	<b>23</b>
		<b>Graco Standard Warranty</b> .....	<b>24</b>

# Models

**Maximum Air Inlet Pressure: 100 psi (0.7 MPa, 6.9 bar)**

**Maximum Fluid Working Pressure: 1450 psi (10.1 MPa, 100.4 bar)**

Pump Model	Displacement Pump Model	Pump Type	Pump Description	Packings
24F625	24G761	Priming Piston	Stubby	Acetal, PTFE, Nitrile, and UHMWPE
24F626	24G762	Priming Piston	Stubby, with extra seal*	Acetal, PTFE, Nitrile, and UHMWPE
24Y567†	24G762	Priming Piston	Stubby, with extra seal*	Acetal, PTFE, Nitrile, and UHMWPE

All models are compliant with: 

EC 1935/2004 compliant pumps may be subject to individual national provisions in addition to those specified in the EC regulation. It is the users responsibility to know and follow local laws.





\* For use with viscous, sticky material.

† "Type 3.1" Certified per DS/EN 10204







# Warnings

The following warnings are for the setup, use, grounding, maintenance, and repair of this equipment. The exclamation point symbol alerts you to a general warning and the hazard symbols refer to procedure-specific risks. When these symbols appear in the body of this manual, refer back to these Warnings. Product-specific hazard symbols and warnings not covered in this section may appear throughout the body of this manual where applicable.



 <b>WARNING</b>	
	<p><b>SKIN INJECTION HAZARD</b></p> <p>High-pressure fluid from dispensing device, hose leaks, or ruptured components will pierce skin. This may look like just a cut, but it is a serious injury that can result in amputation. <b>Get immediate surgical treatment.</b></p> <ul style="list-style-type: none"> <li>• Do not point dispensing device at anyone or at any part of the body.</li> <li>• Do not put your hand over the fluid outlet.</li> <li>• Do not stop or deflect leaks with your hand, body, glove, or rag.</li> <li>• Follow the <b>Pressure Relief Procedure</b> when you stop dispensing and before cleaning, checking, or servicing equipment.</li> <li>• Tighten all fluid connections before operating the equipment.</li> <li>• Check hoses and couplings daily. Replace worn or damaged parts immediately.</li> </ul>
	<p><b>MOVING PARTS HAZARD</b></p> <p>Moving parts can pinch, cut or amputate fingers and other body parts.</p> <ul style="list-style-type: none"> <li>• Keep clear of moving parts.</li> <li>• Do not operate equipment with protective guards or covers removed.</li> <li>• Pressurized equipment can start without warning. Before checking, moving, or servicing equipment, follow the <b>Pressure Relief Procedure</b> and disconnect all power sources.</li> </ul>
	<p><b>FIRE AND EXPLOSION HAZARD</b></p> <p>Flammable fumes, such as solvent and paint fumes, in <b>work area</b> can ignite or explode. To help prevent fire and explosion:</p> <ul style="list-style-type: none"> <li>• Use equipment only in well ventilated area.</li> <li>• Eliminate all ignition sources; such as pilot lights, cigarettes, portable electric lamps, and plastic drop cloths (potential static arc).</li> <li>• Keep work area free of debris, including solvent, rags and gasoline.</li> <li>• Do not plug or unplug power cords, or turn power or light switches on or off when flammable fumes are present.</li> <li>• Ground all equipment in the work area. See <b>Grounding</b> instructions.</li> <li>• Use only grounded hoses.</li> <li>• Hold gun firmly to side of grounded pail when triggering into pail.</li> <li>• If there is static sparking or you feel a shock, <b>stop operation immediately</b>. Do not use equipment until you identify and correct the problem.</li> <li>• Keep a working fire extinguisher in the work area.</li> </ul>

# WARNING

 	<p><b>EQUIPMENT MISUSE HAZARD</b></p> <p>Misuse can cause death or serious injury.</p> <ul style="list-style-type: none"> <li>• Do not operate the unit when fatigued or under the influence of drugs or alcohol.</li> <li>• Do not exceed the maximum working pressure or temperature rating of the lowest rated system component. See <b>Technical Data</b> in all equipment manuals.</li> <li>• Use fluids and solvents that are compatible with equipment wetted parts. See <b>Technical Data</b> in all equipment manuals. Read fluid and solvent manufacturer's warnings. For complete information about your material, request MSDS from distributor or retailer.</li> <li>• Do not leave the work area while equipment is energized or under pressure. Turn off all equipment and follow the <b>Pressure Relief Procedure</b> when equipment is not in use.</li> <li>• Check equipment daily. Repair or replace worn or damaged parts immediately with genuine manufacturer's replacement parts only.</li> <li>• Do not alter or modify equipment.</li> <li>• Use equipment only for its intended purpose. Call your distributor for information.</li> <li>• Route hoses and cables away from traffic areas, sharp edges, moving parts, and hot surfaces.</li> <li>• Do not kink or over bend hoses or use hoses to pull equipment.</li> <li>• Keep children and animals away from work area.</li> <li>• Comply with all applicable safety regulations.</li> </ul>
	<p><b>SPLATTER HAZARD</b></p> <p>Hot or toxic fluid can cause serious injury if splashed in the eyes or on skin. During blow off of platen, splatter may occur.</p> <ul style="list-style-type: none"> <li>• Use minimum air pressure when removing platen from drum.</li> </ul>
	<p><b>TOXIC FLUID OR FUMES HAZARD</b></p> <p>Toxic fluids or fumes can cause serious injury or death if splashed in the eyes or on skin, inhaled, or swallowed.</p> <ul style="list-style-type: none"> <li>• Read MSDSs to know the specific hazards of the fluids you are using.</li> <li>• Store hazardous fluid in approved containers, and dispose of it according to applicable guidelines.</li> </ul>
	<p><b>PERSONAL PROTECTIVE EQUIPMENT</b></p> <p>You must wear appropriate protective equipment when operating, servicing, or when in the operating area of the equipment to help protect you from serious injury, including eye injury, hearing loss, inhalation of toxic fumes, and burns. This equipment includes but is not limited to:</p> <ul style="list-style-type: none"> <li>• Protective eyewear, and hearing protection.</li> <li>• Respirators, protective clothing, and gloves as recommended by the fluid and solvent manufacturer.</li> </ul>

# Installation

## Grounding

							
<p>The equipment must be grounded. Grounding reduces the risk of static and electric shock by providing an escape wire for the electrical current due to static build up or in the event of a short circuit.</p>							

**Pump:** Connect a ground wire (Graco PN 238909) to the ground screw on the bottom cover of the air motor, under the shroud. Connect the other end of the ground wire to a true earth ground.

**Air and fluid hoses:** use only electrically conductive hoses with a maximum of 500 ft. (150 m) combined hose length to ensure grounding continuity. Check electrical resistance of hoses. If total resistance to ground exceeds 25 megohms, replace hose immediately.

**Air compressors:** follow manufacturer's recommendations.

**Dispense valve:** ground through connection to a properly grounded fluid hose and pump.



**Material supply container:** follow local code.

**Container(s) that receive material:** follow local code.

**Solvent pails used when flushing:** follow local code. Use only conductive metal pails, placed on a grounded surface. Do not place the pail on a nonconductive surface, such as paper or cardboard, which interrupts grounding continuity.



**To maintain grounding continuity when flushing or relieving pressure:** hold metal part of the dispense valve firmly to the side of a grounded metal pail, then trigger the valve.

## Mounting

							
<p>To avoid injury from a falling pump, check the torque on the lift ring (16) and nut (15) before using the lift ring to lift the pump. Torque to 30-36 ft-lb (41-49 N•m).</p>							

Mount the pump on a surface than can support the weight of the pump and accessories, as well as the stress caused during operation. Do not use air or fluid lines to support the pump.

## Setup

							
<p>To avoid contaminating the fluid, pipe the exhaust air to vent outside of the fluid product area, away from people, animals, or food-handling areas.</p>							

**NOTE:** Reference numbers and letters in parentheses in the text refer to the callouts in the figures and the parts drawings.

Accessories are available from Graco. Make certain all accessories are sized and pressure-rated to meet your system requirements.

FIG. 1 is only a guide for selecting and installing system components and accessories. Contact your Graco distributor for assistance in designing a system to suit your particular needs.

Install a bleed-type master air valve (G) close to the pump air inlet (D), to relieve air trapped between it and the air motor.

Install an air filter/regulator (F) in the pump air line, *upstream from the bleed valve*, to control air inlet pressure and to remove harmful dirt and contaminants from your compressed air supply.

Install a pump runaway valve (S) in the pump air line to shut off air to the air motor automatically if the pump starts to run too fast.

Install another bleed-type master air valve (G) upstream from all air line accessories and use it to isolate the accessories during cleaning and repair.

On the air drop to the dispense valve (K), install an air regulator (M) to control air pressure to the valve. Install a bleed valve (G) to use as a shutoff when servicing the dispense valve.

Connect air solenoid valves (H) to a timer control (L), and set so the dispense valve (K) will dispense at proper intervals.

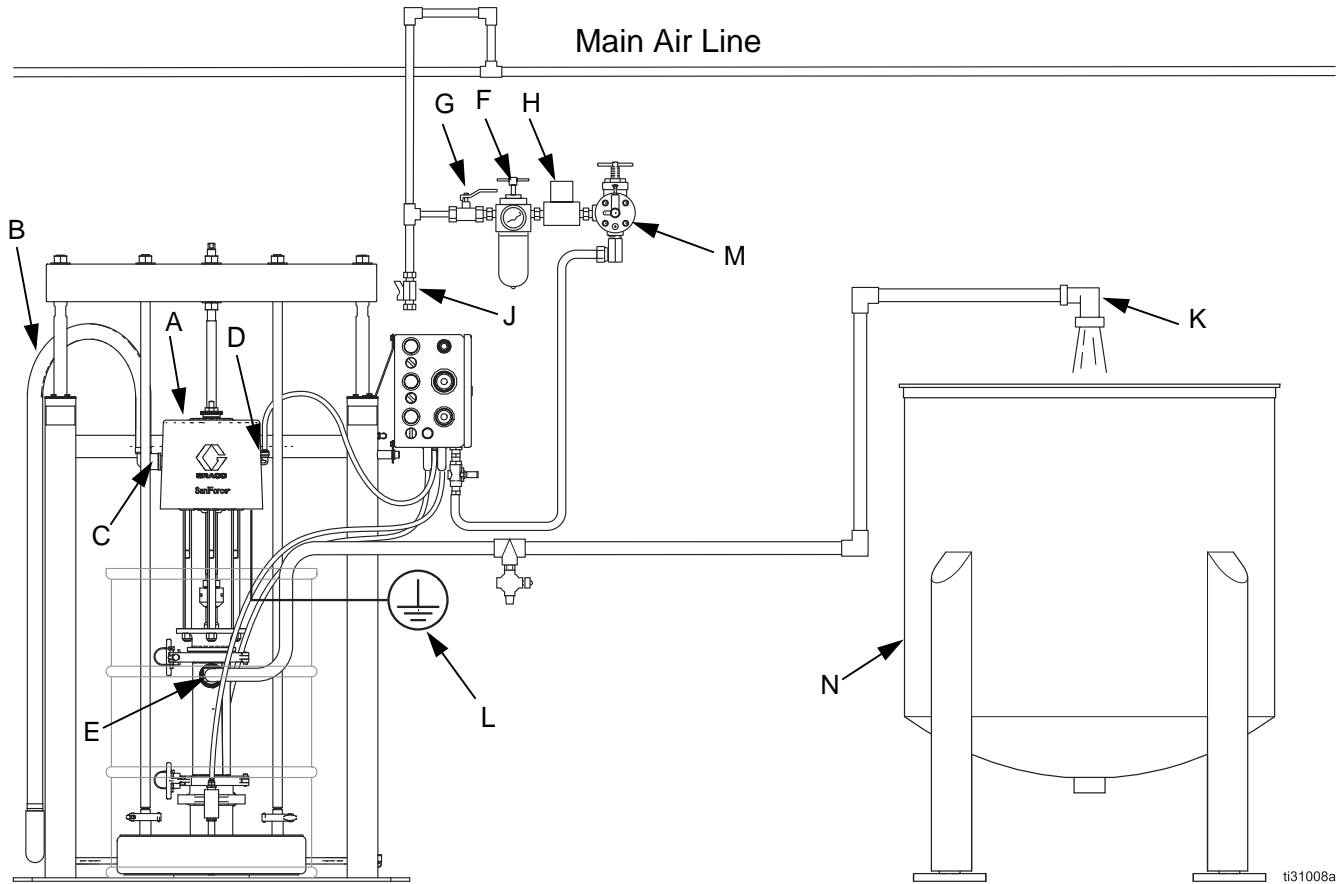

FIG. 1. Typical installation

**Key:**

**Pump Components (Included)**

- A Drum Unloader-Mounted Sanitary Pump
- B Air Exhaust Muffler (may alternately be mounted remotely, using exhaust hose)
- C 3/4 npt Exhaust Air Outlet
- D 1/2 npt Air Inlet
- E 2 in. Tube Size Flanged Fluid Outlet

**System Components/Accessories (sold separately)**

- F Air Line Filter/Regulator
- G Bleed-Type Master Air Valve (required)
- H Air Solenoid Valve
- J Air Line Drain Pipe and Valve
- K Dispensing Nozzle
- L Pump Ground Wire (required)
- M Pump Runaway Valve
- N Storage Vessel

# Operation

## NOTICE

Do not expose the air motor to temperatures higher than 120°F (49°C) or the immersed fluid pump to temperatures higher than 160°F (71°C). Excessive temperatures may damage the pump packings and seals.

## Pressure Relief Procedure



Trapped air can cause the pump to cycle unexpectedly, which could result in serious injury from injection, splashing, or moving parts. Relieve pressure when you stop pumping and before cleaning, checking, or servicing equipment.

1. Shut off the air supply to the pump.
2. Close the bleed-type master air valve (required in system).
3. Open the fluid ball valve and/or dispensing valve to relieve fluid pressure.

## Flush Before First Use

The sanitary pump was assembled using sanitary lubricant on moving parts and was tested in water. Flush the pump thoroughly with an appropriate cleaning solution, and disassemble and sanitize the parts before using the pump. See **Flushing Procedure**, page 9. Check national, state, and local codes for specific limitations.

## Adjusting the Pump Speed and Pressure

Set pressure regulator to 0 psi. Open the bleed-type master air valve. Adjust the pump air regulator until the pump is running smoothly.

Allow the pump to cycle slowly until all air is pushed out of the lines (the fluid will flow in a steady stream from the fluid outlet) and the pump is primed.

With the air supply turned on, the pump will start when the dispensing valve is opened and stall against pressure when the valve is closed. In a circulating system, the pump operates until the air supply is turned off.

## NOTICE

Never allow the pump to run dry of fluid. A dry pump will accelerate to a high speed, possibly damaging itself.

If the pump accelerates quickly, or is running too fast, stop the pump immediately and check the fluid supply. If the supply is empty and air has been pumped into the lines, refill the container and prime the pump and lines with fluid. Be sure to eliminate all air from the system.

## Pump Shutdown

Follow the **Pressure Relief Procedure**, page 8. Always stop the pump at the bottom of its stroke to prevent fluid from drying on the displacement rod. (The air motor will exhaust at the bottom and top of the stroke.)



# Maintenance

## Flushing Procedure



### NOTE:

- Flush before fluid can dry in the equipment, at the end of the day, before storing, and before repairing equipment.
  - Flush at the lowest pressure possible. Check connectors for leaks and tighten as necessary.
  - Flush with an appropriate cleaning solution.
1. Remove the pump from the fluid container. Operate it at a slow rate to pump out as much fluid as possible.
  2. Follow **Pressure Relief Procedure**, page 8.
  3. Place siphon tube in grounded metal pail containing an appropriate cleaning solution.
  4. Set pump air regulator to lowest possible fluid pressure, and start pump.
  5. Run the pump long enough to thoroughly clean the pump and hoses.
  6. Follow **Pressure Relief Procedure**, page 8.

## Cleaning Procedure

**NOTE:** The following instructions are a basic procedure for cleaning a sanitary pump.

- **Be sure** to follow your national and state sanitary standard codes and local regulations.
- Use appropriate cleaning and disinfecting agents, at intervals appropriate for product processed.
- Follow cleaning product manufacturer's instructions.

**NOTE:** The pump **must be disassembled** to clean it thoroughly.

1. Remove the pump from the fluid container. Operate it at a slow rate to pump out as much fluid as possible.

2. Flush the system thoroughly with an appropriate cleaning solution. See **Flushing Procedure**, page 9.
3. Follow the **Pressure Relief Procedure**, page 8.
4. Remove the air and fluid hoses and fittings from the pump.
5. **Ram-Mounted Pumps:** Loosen the hand screw and lift the upper shroud straight up on the rod. **Other Pumps:** Remove the upper shroud.
6. Clean thoroughly the surface between the upper and lower shrouds.
7. Disassemble the fluid pump and accessories. See **Disassemble the Pump**, page 11.
8. Wash all pump parts with an appropriate cleaning solution at the cleaning product manufacturer's recommended temperature and concentration.
9. Rinse all pump parts again with water and allow them to dry.
10. Inspect all pump parts and reclean if needed.

**NOTE:** Any damaged rubber parts **must** be replaced as they could harbor microorganisms that can contaminate the fluid.

11. Immerse all pump parts in an appropriate sanitizer before assembly. Take the pump parts out of the sanitizer one-by-one as needed.
12. Lubricate the moving pump parts and o-rings, packings, and seals with appropriate waterproof sanitary lubricant.
13. Circulate the sanitizing solution through the pump and the system prior to use.
14. **Ram-Mounted Pumps:** Clean all ram surfaces. Remove and clean the inflatable seal and ram plate. See Manual 3A0591.

## Tighten Connections

Before each use, check all hoses for wear or damage. Replace as necessary. Check that all connections are tight and leak-free.

# Troubleshooting



1. Follow **Pressure Relief Procedure**, page 8.
2. Check all possible remedies in the Troubleshooting Chart before disassembling the pump.

Problem	Cause	Solution
Pump fails to operate.	Restricted air line or inadequate air supply.	Clear air line or increase air supply.
	Insufficient air pressure; closed or clogged air valves, etc.	Open or clean air valves, etc.
	Exhausted fluid supply.	Refill fluid supply.
	Damaged air motor.	Service.
Pump operates, but output low on both strokes.	Restricted air line or inadequate air supply.	Clear air line or increase air supply.
	Insufficient air pressure; closed or clogged air valves, etc.	Open or clean air valves, etc.
	Exhausted fluid supply.	Refill fluid supply.
	Obstructed fluid line, valves, dispensing valve, etc.	Clear. Relieve pressure and disconnect fluid line. Turn on air. If pump starts, the fluid line is clogged.
	Worn throat packing (103).	Replace throat packing.
	Damaged cylinder o-ring (123).	Replace o-ring.
Pump operates, but output low on down stroke.	Held open or worn fluid inlet valve.	Clear or service fluid inlet valve.
	Damaged cylinder o-ring (123).	Replace o-ring.
Pump operates, but output low on up stroke.	Held open or worn fluid piston or seal (109, 110).	Clear or service fluid piston or seal.
Erratic or accelerated operation.	Exhausted fluid supply.	Refill fluid supply.
	Held open or worn fluid inlet valve.	Clear or service fluid inlet valve.
	Held open or worn fluid piston or seal (109, 110).	Clear or service fluid piston or seal.

# Service

## Disconnect the Pump



Moving parts can pinch, cut or amputate fingers and other body parts. Keep your hands and fingers away from the priming piston during operation and whenever the pump is charged with air.

1. Remove the pump from the fluid container. Operate it at a slow rate to pump out as much fluid as possible.
2. Follow the **Pressure Relief Procedure**, page 8.
3. Remove the air and fluid hoses from the pump. **Ram-mounted pumps:** leave ram air connected for now.

4. Hold the reducer fitting with a wrench. Use a spanner wrench (T)\* to loosen the coupling nut.  
\*A Graco spanner wrench (p/n 112887) is available.

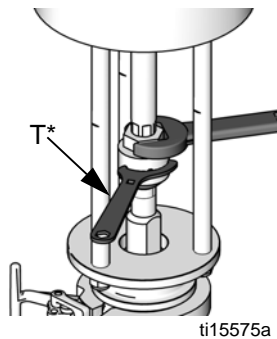

5. Lower the coupling nut enough to remove the coupling collars.

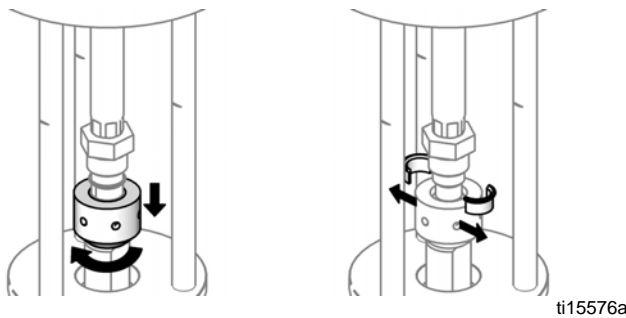

6. Remove the clamps holding the pump base to the ram or drum. **Ram-mounted pumps:** Use the ram to lift the air motor. Disconnect air lines.
7. Remove the clamp holding the displacement pump to the air motor. Carry the displacement pump to the bench for service.

## Disassemble the Pump

**NOTE:** Pump Repair Kits are available. Purchase the kit separately. See the Parts list on page 19 to select the correct kit for your pump. Kit parts are marked with an \*.

1. With the pump on its side, tap the displacement rod (105) with a rubber mallet to drive the priming piston assembly out of the base (102).
2. Hold the valve plate guide (119) with a wrench. Use another wrench to remove the priming piston nut (122).

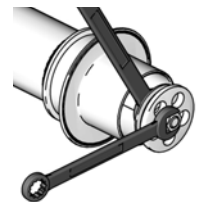

ti15565a

3. Remove the priming piston (121) and the valve plate (120).
4. Remove the clamp (118) from the base (102). Then remove the base (102). Tap with a rubber mallet to loosen, if needed.
5. Remove the o-ring (123) and the spacer (113). Tap the displacement rod again to drive the displacement rod/priming piston rod assembly (105/106) out of the cylinder (101).
6. Hold the rod (106) with a wrench and remove the priming piston guide (119).

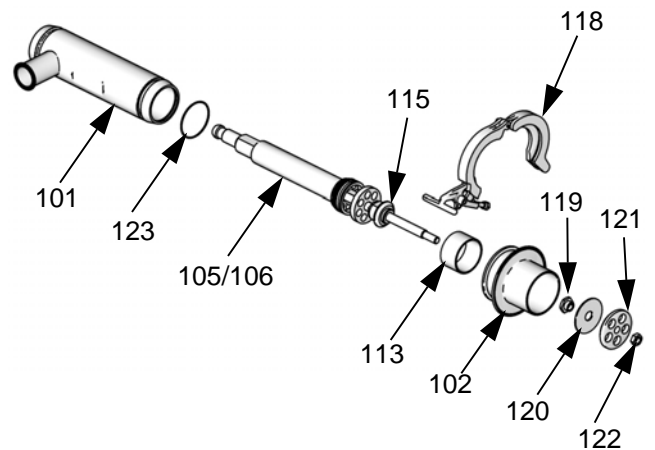

ti15566a

**FIG. 2. Remove piston rod**

7. Hold the piston rod (106) with a wrench. Use another wrench to loosen the intake valve housing (115), then remove it. If the intake valve housing (115) is stuck to the rod, tap with a plastic rod and mallet.
8. Screw out the packing nut (117) and remove the packing stack (116) from the intake valve housing (115).

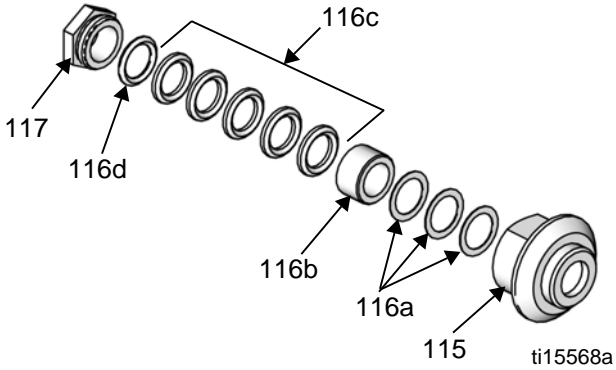

**FIG. 3. Intake valve housing**

9. Remove the valve plate (112). Use wrenches on the displacement rod flats (105) and the piston rod flats (106) to disconnect.



10. Remove the valve plate (108) and the piston (107). Remove the bearings (110) from the piston. (Model 24G761 has two bearings; Model 24G762 has three bearings.)

**NOTE: On Displacement Pump Model 24G761,** carefully remove the u-cup seal (109). Use a pick, not a screwdriver, as the packing may deform.

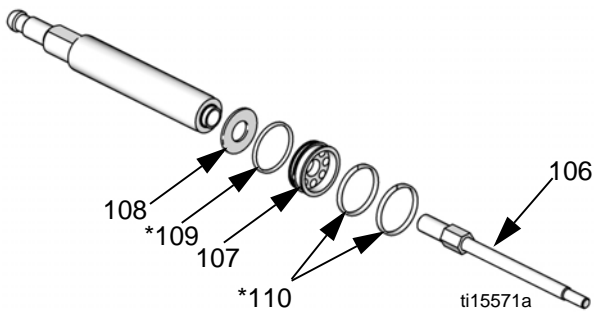

**FIG. 4. Remove piston and seals**

11. Stand cylinder upright. Remove the u-cup seal assembly, which includes the base (103a), insert (103b), o-ring (103d), and u-cup (103c).

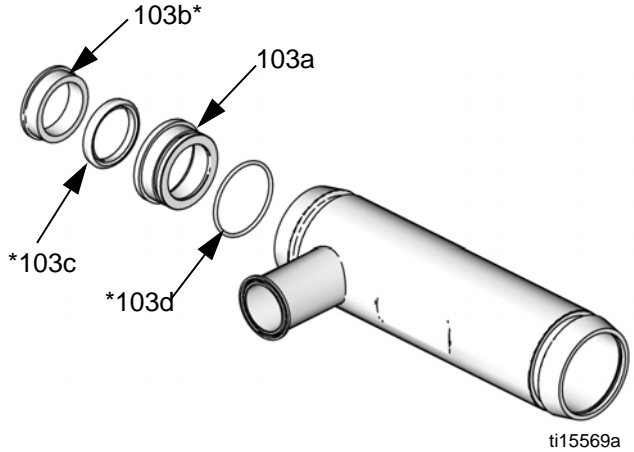

**FIG. 5. Remove u-cup seal assembly**

12. Refer to the **Cleaning Procedure** on page 9. Clean the parts and inspect them for wear or damage. Replace them as necessary.

## Reassemble the Pump

**NOTE:** Any damaged rubber parts **must** be replaced as they could harbor microorganisms that can contaminate the fluid.

**NOTE:** Lubricate the o-rings, throat packings, and piston seals with appropriate waterproof sanitary lubricant prior to installation.

1. Install the bearings (110\*) and the u-cup seal (109\*, 24G761 only) on the piston (107). The lips of the piston u-cup must face up. Install the valve plate (108) and piston assembly on the displacement rod (105). Cutout on piston must face down.
2. Use wrenches on the displacement rod flats and the piston rod flats to reconnect. Torque to 60-70 ft-lb (81-95 N•m).
3. Install the packing stack (116\*) into the intake valve housing (115). Maintain the following order: shims (116a), female gland (116b), five v-packings (116c) with the lips facing up, and male gland (116d). Loosely thread packing nut (117) into the valve housing (115).

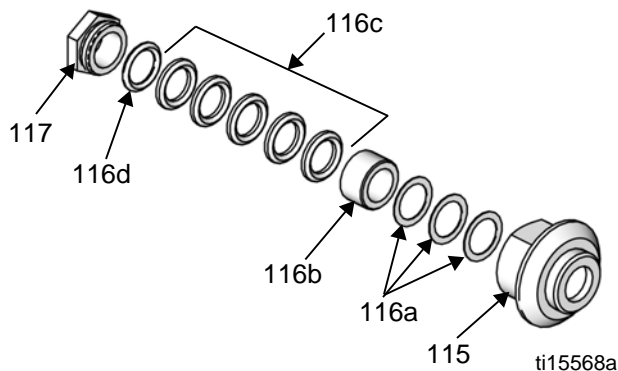

**FIG. 6. Intake valve housing**

4. Install the u-cup (103c\*) and insert (103b\*) into the u-cup seal assembly base (103a). Throat u-cup lips must face down. Then install the o-ring (103d\*).
5. Lubricate the displacement rod/piston rod assembly and slide into the cylinder from the top.
6. Install the u-cup assembly (103) in the top of the cylinder (101). Reassembly may be difficult. Use steady force until the assembly drops into place.

7. Turn the pump on its side. Use a rubber mallet to tap the displacement rod so the piston rod extends well out of the cylinder.
8. Install the valve plate (112) and the spacer (113) into the bottom of the cylinder. Install the cylinder o-ring (123\*).

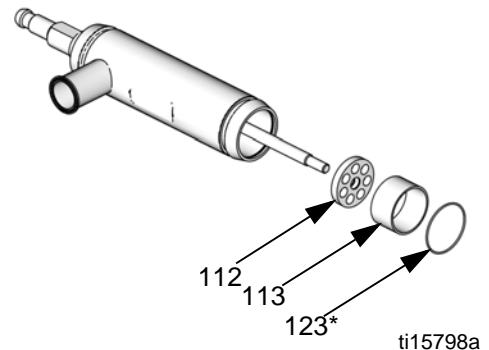

**FIG. 7. Valve plate**

9. Lubricate the piston rod and the inside of the packing nut (117) and intake valve housing (115). Slide the assembly onto the piston rod, then use two wrenches to tighten the valve housing.
10. Stand the pump upright, placing the cylinder (101) into the base (102). Reattach the clamp to hold the base (102) to the cylinder (101). Replace the pin (125).
11. Turn the pump on its side. Use a rubber mallet to tap the displacement rod so the piston rod extends well out of the cylinder.
12. Hold the displacement rod (105) with a wrench. Screw on the guide (119) and use another wrench to tighten.
13. Install the valve plate (120) and the priming piston (121). Hand tighten the priming piston nut (122).
14. Hold the displacement rod (105) with a wrench. Use another wrench to tighten the priming piston nut (122).

## Reconnect the Pump

1. **Ram-mounted pumps:** Set the displacement pump in place, then attach the clamp. Align the air motor and set it on top of the displacement pump. Attach the clamp. Replace the pin.
2. **Other pumps:** Slide the assembled displacement pump into position on the air motor pump adapter and reattach the clamp.
3. Hold the motor shaft up with one hand. With your other hand, put the coupling nut (5) on the rod.
4. Put the coupling collars (4) into the coupling nut so large flanges point upward.
5. Gently let the motor shaft drop onto the rod. Use a spanner wrench to tighten the coupling nut securely. A Graco spanner wrench tool (p/n 112887) is available.
6. Connect the remaining air and fluid hoses and the ground wire.



# Parts

## Complete Pump Models 24F625, 24Y567 and 24F626

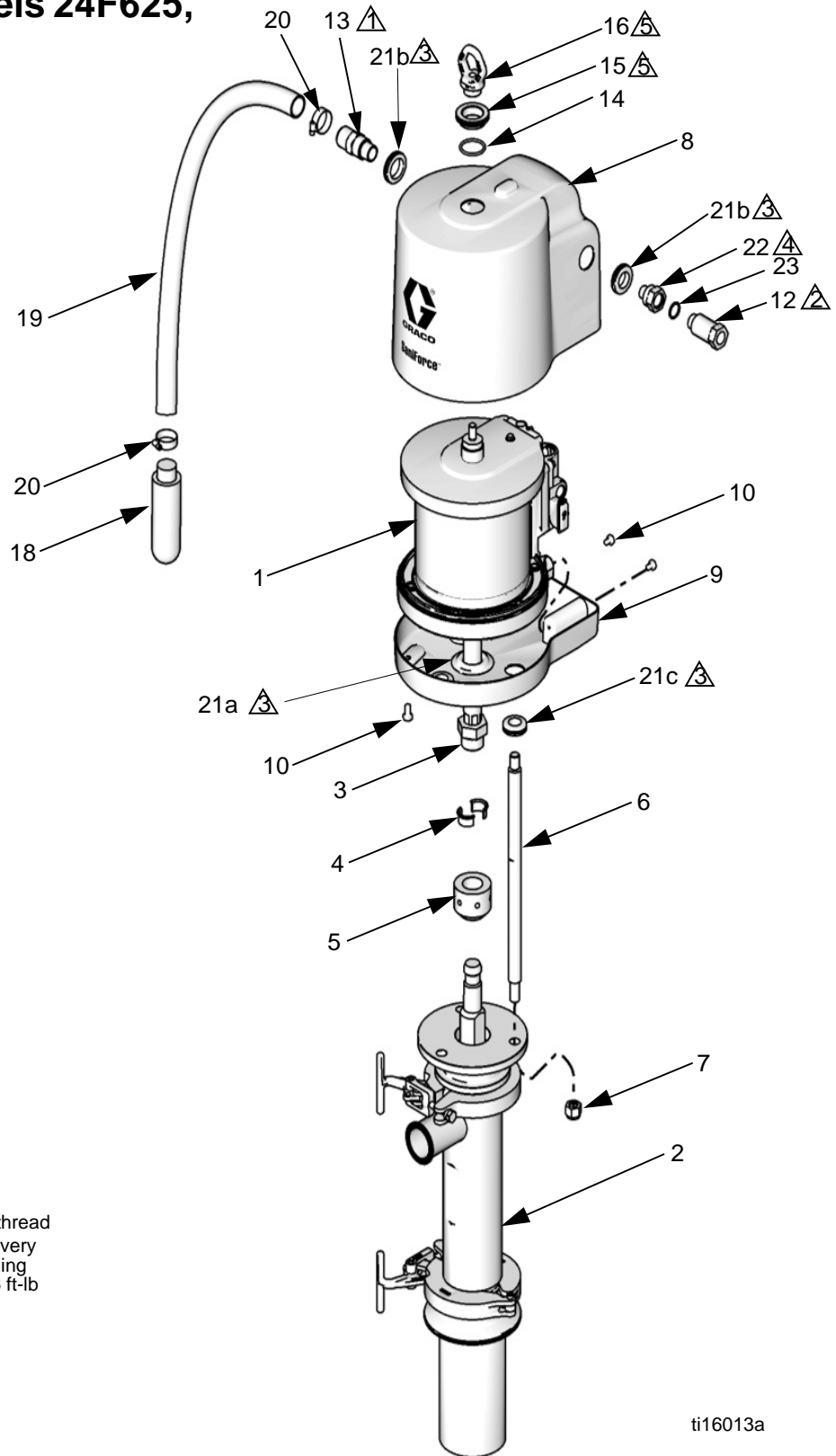

ti16013a



## Complete Pump Models 24F625, 24Y567 and 24F626

Ref	Part	Description	Qty	Ref	Part	Description	Qty
1	24G787	MOTOR, SaniForce; 7.5 in.; see manual 3A1211	1	10	118134	SCREW, cap, M8 x 1.25, sst; see <b>Kits</b>	4
2		DISPLACEMENT PUMP	1	12	24G862	FITTING, air inlet, 1/2 npt, Includes Ref. 23	1
	24G761	Model 24F625		13	16C946	FITTING, 3/4 npt	1
	24G762	Model 24F626		14	165053	O-RING, PTFE	1
3	16A939	COUPLER	1	15	16C306	NUT, hand	1
4	184130	COLLAR, coupling	2	16	16C009	RING, lift	1
5	626045	COUPLING	1	17▲	280574	LABEL, warning, not shown	1
6	16C010	TIE ROD, 13.3 in. (338 mm) between shoulders	3	18	512914	MUFFLER; see <b>Kits</b>	1
7	102216	NUT, lock, 5/8-11, sst	3	19	-----	HOSE, exhaust; see	1
8	16G380	SHROUD, upper; includes grommets (Ref. 21)	1	20	101818	CLAMP, hose; see <b>Kits</b>	2
9	16G382	SHROUD, lower; includes fasteners (Ref. 10) and grommets (Ref. 21)	1	21	-----	GROMMET; see <b>Kits</b>	6
				22	16G084	FITTING, air inlet, 1/2 npt	1
				23	166702	O-RING, air inlet, buna-n	1

▲ Replacement Danger and Warning labels, tags, and cards are available at no cost.

## Kits

### Muffler Kit 16G390

Ref.	Part	Description	Qty
18	512914	MUFFLER, polyethylene	2

### Exhaust Assembly Kit 16G389

Ref.	Part	Description	Qty
18	512914	MUFFLER, polyethylene	1
19	-----	HOSE, exhaust, 6 ft.	1
20	101818	CLAMP, hose	2

### Lower Shroud Fastener Kit 16G432

Ref.	Part	Description	Qty
10	118134	SCREW, cap, M8 x 1.25, sst	4

### Grommet Kit 16G385

Ref.	Part	Description	Qty
21a*	-----	GROMMET, air motor piston rod	1
21b	-----	GROMMET, air fitting	2
21c	-----	GROMMET, tie rod	3

\* Order Kit 16G384 for qty. 3 of the piston rod grommet.

### Spanner Wrench

Ref.	Part	Description	Qty
	112887	WRENCH, spanner	1

# Displacement Pump Models 24G761 and 24G762

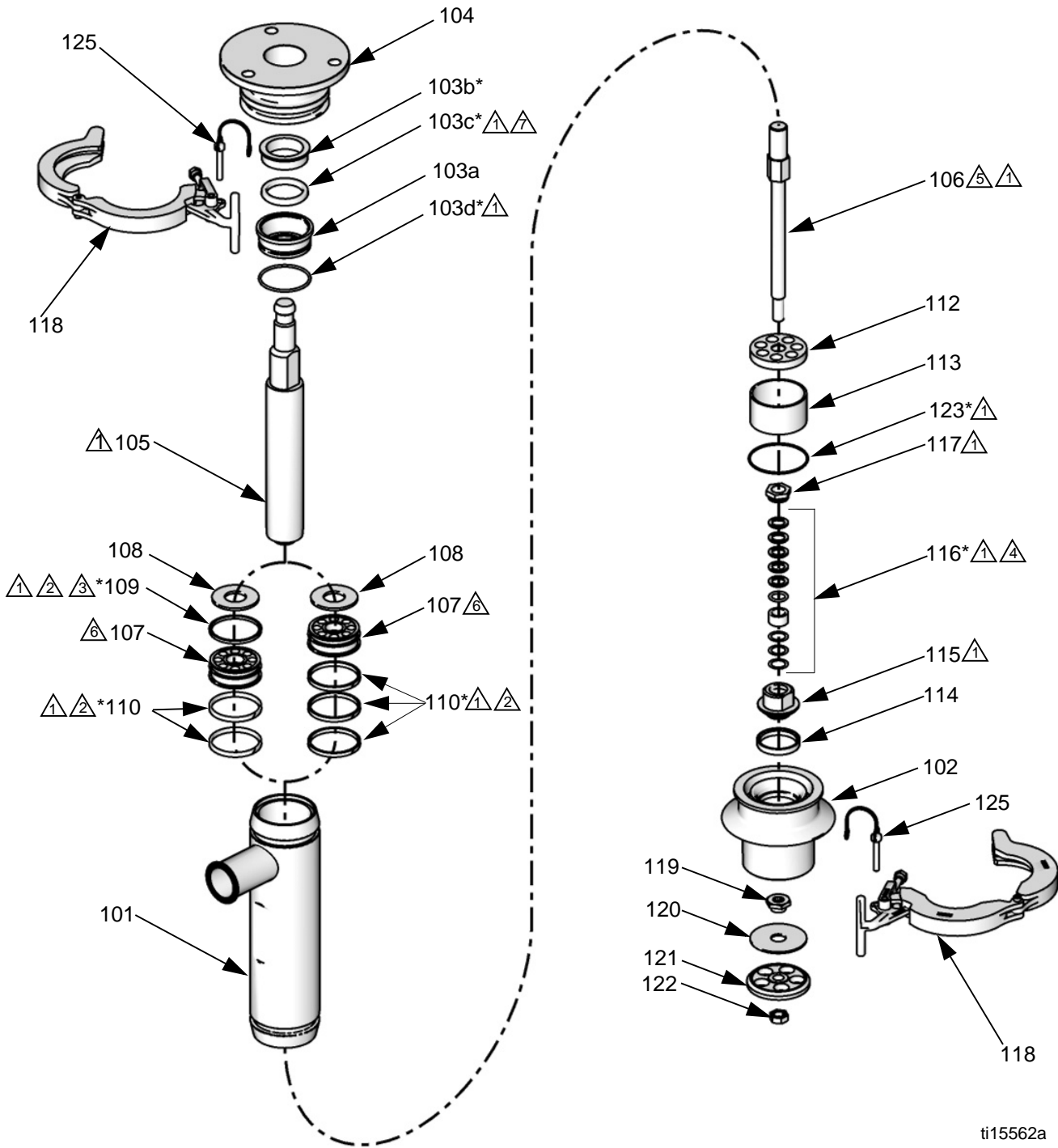

ti15562a

- △ Apply appropriate waterproof, sanitary lubricant.
- △ Model 24G761 has a u-cup (109) and two bearings (110). Model 24G762 has three bearings (110) and no u-cup (109).
- △ Piston u-cup lips must face UP.

- △ V-packing lips must face UP.
- △ Torque to 60-70 ft-lb (81-95 N•m).
- △ Cutout on piston must face DOWN.
- △ Throat u-cup lips must face DOWN.

## Displacement Pump Models 24G761 and 24G762

Ref	Part	Description	Qty	Ref	Part	Description	Qty
101	16G430	CYLINDER, pump	1	113	16A847	SPACER	1
102	16G431	BASE, pump, includes Part 114	1	114	167481	SEAT, valve	1
103a	-----	BASE, u-cup; see <b>Kits</b> for <i>U-Cup Seal Assembly</i>	1	115	167482	HOUSING, intake valve seal	1
103b*	-----	INSERT; see <b>Kits</b> for <i>U-Cup Seal Assembly</i>	1	116*	-----	STACK, gland/packing	1
103c*	-----	U-CUP; see <b>Kits</b> for package of <i>5 with o-ring (part 103d)</i>	1	117	167486	NUT, packing	1
103d*	-----	O-RING; see <b>Kits</b> for package <i>of 5 with u-cup (part 103c)</i>	1	118	16G386	CLAMP, assembly	2
104	16E465	ADAPTER, tie rod	1	119	167480	GUIDE, valve plate, pump	1
105	16G436	ROD, displacement	1	120	167479	PLATE, priming piston valve	1
106	16G437	ROD, priming piston	1	121	172200	PISTON, priming	1
107	181892	PISTON, cylinder	1	122	102533	NUT, plain hex	1
108	167493	PLATE, piston valve	1	123*	16D164	O-RING, 152, nitrile	1
109*	108543	U-CUP, UHMWPE, Model 24G761 only	1	125	16F603	PIN, locking, 5/16 in.	2
110*	181897	BEARING Model 24G761	2	* <i>Parts included in Repair Kit 24G555 (Displacement Pump Model 24G761) or Repair Kit 24G556 (Dis- placement Pump Model 24G762).</i>			
		Model 24G762	3				
112	16A846	PLATE, intake valve	1				

## Kits

### U-Cup Seal Assembly Kit 24C623

Ref.	Part	Description	Qty
			.
103a	-----	BASE	1
103b	-----	INSERT	1
103c	-----	U-CUP SEAL	1
103d	-----	O-RING	1

### U-Cup Seal/O-Ring Kit 24G858

Ref.	Part	Description	Qty
			.
103c	-----	U-CUP SEAL	4
103d	-----	O-RING	4

### Spanner Wrench

Ref.	Part	Description	Qty
			.
	112887	WRENCH, spanner	1



# Dimensions

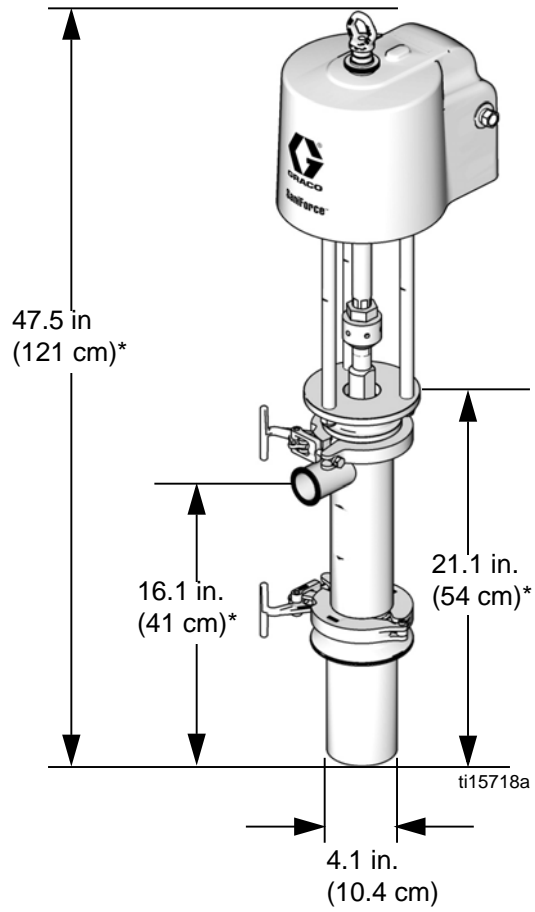

\* Add 4.7 in. (12 cm) to allow for full extension of the priming piston rod.

# Performance Chart

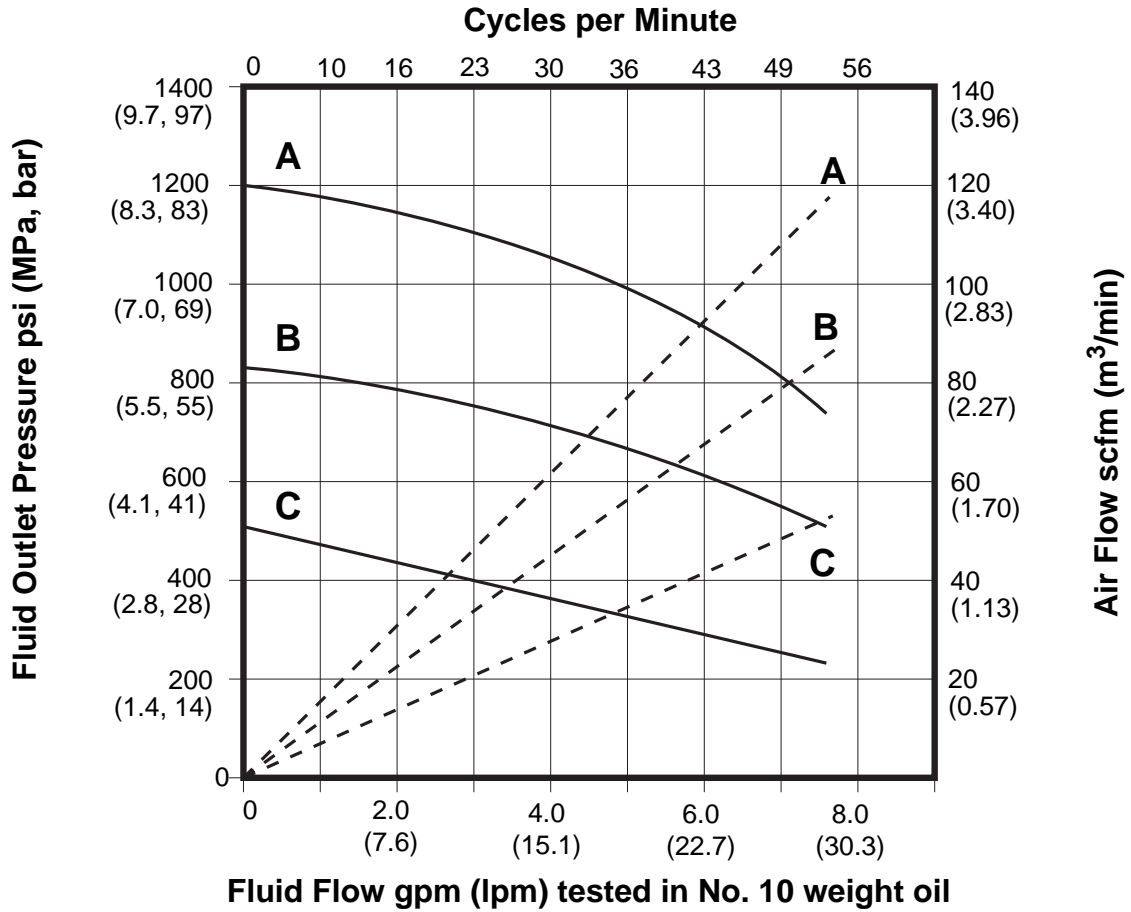

Fluid Flow gpm (lpm) tested in No. 10 weight oil

### KEY

- A** = 100 psi (0.7 MPa, 7 bar)
- B** = 70 psi (0.5 MPa, 5 bar)
- C** = 40 psi (0.3 MPa, 3 bar)
- = fluid flow
- - -** = air consumption

# Technical Data

Maximum Fluid Working Pressure . . . . .	1450 psi (10.1 MPa, 100.4 bar)
Maximum Air Inlet Pressure . . . . .	100 psi (0.7 MPa, 6.9 bar)
Maximum Recommended Pump Speed . . . . .	60 cycles/min, 8.5 gpm (32 liters/min) delivery
Maximum size pumpable solids	1/4 in. (6.4 mm)
Air Consumption . . . . .	See <b>Performance Chart</b> , page 22
Pump Cycles per Gallon (3.8 Liters) . . . . .	7.1
Ratio . . . . .	12:1
Maximum Operating Temperature . . . . .	160°F (71°C)
Maximum Ambient Temperature (air motor) . . . . .	120°F (49°C)
Air Inlet . . . . .	1/2 in. npt(f)
Air Exhaust . . . . .	3/4 in. npt(m)
Fluid Inlet Type . . . . .	4.1 in. (10.4 cm) tube with flange for 6 in. (15.2 cm) Tri-Clamp®
Fluid Outlet . . . . .	2 in. (5.1 cm) Tri-Clamp®
Weight . . . . .	122 lb (55.3 kg)
Wetted Parts . . . . .	stainless steel (300 series or other corrosion-resistant grades), Acetal, Buna-N, PTFE, UHMWPE
Sound data	
Sound power* . . . . .	77.2 dBA
Sound pressure** . . . . .	70.5 dBA

\* Sound power at 70 psi (0.48 MPa, 4.8 bar), 20 cpm. Sound power measured per ISO-9614-2.

\*\* Sound pressure was tested 3.28 feet (1 m) from equipment.

## California Proposition 65

### CALIFORNIA RESIDENTS

 **WARNING:** Cancer and reproductive harm – [www.P65warnings.ca.gov](http://www.P65warnings.ca.gov).

# Graco Standard Warranty

Graco warrants all equipment referenced in this document which is manufactured by Graco and bearing its name to be free from defects in material and workmanship on the date of sale to the original purchaser for use. With the exception of any special, extended, or limited warranty published by Graco, Graco will, for a period of twelve months from the date of sale, repair or replace any part of the equipment determined by Graco to be defective. This warranty applies only when the equipment is installed, operated and maintained in accordance with Graco's written recommendations.

This warranty does not cover, and Graco shall not be liable for general wear and tear, or any malfunction, damage or wear caused by faulty installation, misapplication, abrasion, corrosion, inadequate or improper maintenance, negligence, accident, tampering, or substitution of non-Graco component parts. Nor shall Graco be liable for malfunction, damage or wear caused by the incompatibility of Graco equipment with structures, accessories, equipment or materials not supplied by Graco, or the improper design, manufacture, installation, operation or maintenance of structures, accessories, equipment or materials not supplied by Graco.

This warranty is conditioned upon the prepaid return of the equipment claimed to be defective to an authorized Graco distributor for verification of the claimed defect. If the claimed defect is verified, Graco will repair or replace free of charge any defective parts. The equipment will be returned to the original purchaser transportation prepaid. If inspection of the equipment does not disclose any defect in material or workmanship, repairs will be made at a reasonable charge, which charges may include the costs of parts, labor, and transportation.

**THIS WARRANTY IS EXCLUSIVE, AND IS IN LIEU OF ANY OTHER WARRANTIES, EXPRESS OR IMPLIED, INCLUDING BUT NOT LIMITED TO WARRANTY OF MERCHANTABILITY OR WARRANTY OF FITNESS FOR A PARTICULAR PURPOSE.**

Graco's sole obligation and buyer's sole remedy for any breach of warranty shall be as set forth above. The buyer agrees that no other remedy (including, but not limited to, incidental or consequential damages for lost profits, lost sales, injury to person or property, or any other incidental or consequential loss) shall be available. Any action for breach of warranty must be brought within two (2) years of the date of sale.

**GRACO MAKES NO WARRANTY, AND DISCLAIMS ALL IMPLIED WARRANTIES OF MERCHANTABILITY AND FITNESS FOR A PARTICULAR PURPOSE, IN CONNECTION WITH ACCESSORIES, EQUIPMENT, MATERIALS OR COMPONENTS SOLD BUT NOT MANUFACTURED BY GRACO.** These items sold, but not manufactured by Graco (such as electric motors, switches, hose, etc.), are subject to the warranty, if any, of their manufacturer. Graco will provide purchaser with reasonable assistance in making any claim for breach of these warranties.

In no event will Graco be liable for indirect, incidental, special or consequential damages resulting from Graco supplying equipment hereunder, or the furnishing, performance, or use of any products or other goods sold hereto, whether due to a breach of contract, breach of warranty, the negligence of Graco, or otherwise.

## **FOR GRACO CANADA CUSTOMERS**

The Parties acknowledge that they have required that the present document, as well as all documents, notices and legal proceedings entered into, given or instituted pursuant hereto or relating directly or indirectly hereto, be drawn up in English. Les parties reconnaissent avoir convenu que la rédaction du présente document sera en Anglais, ainsi que tous documents, avis et procédures judiciaires exécutés, donnés ou intentés, à la suite de ou en rapport, directement ou indirectement, avec les procédures concernées.

# Graco Information

For the latest information about Graco products, visit [www.graco.com](http://www.graco.com).

For patent information, see [www.graco.com/patents](http://www.graco.com/patents).

**TO PLACE AN ORDER**, contact your Graco distributor or call to identify the nearest distributor.

**Phone:** 612-623-6921 **or Toll Free:** 1-800-328-0211 **Fax:** 612-378-3505

*All written and visual data contained in this document reflects the latest product information available at the time of publication. Graco reserves the right to make changes at any time without notice.*

Original instructions. This manual contains English. MM 3A0735

**Graco Headquarters:** Minneapolis

**International Offices:** Belgium, China, Japan, Korea

**GRACO INC. AND SUBSIDIARIES • P.O. BOX 1441 • MINNEAPOLIS MN 55440-1441 • USA**

**Copyright 2010, Graco Inc. All Graco manufacturing locations are registered to ISO 9001.**

[www.graco.com](http://www.graco.com)

Revision P, December 2021