

# PR70e<sup>TM</sup>

334135F

Compact Benchtop Meter, Mix and Dispense System

EN

Use for accurate metering, mixing and dispensing of two-component sealants and adhesives in fixed ratios. For professional use only.

Not approved for use in explosive atmospheres or hazardous locations.

Refer to **Models**, page 3, for maximum working pressures.



### Important Safety Instructions

Read all warnings and instructions in this manual. Save these instructions.

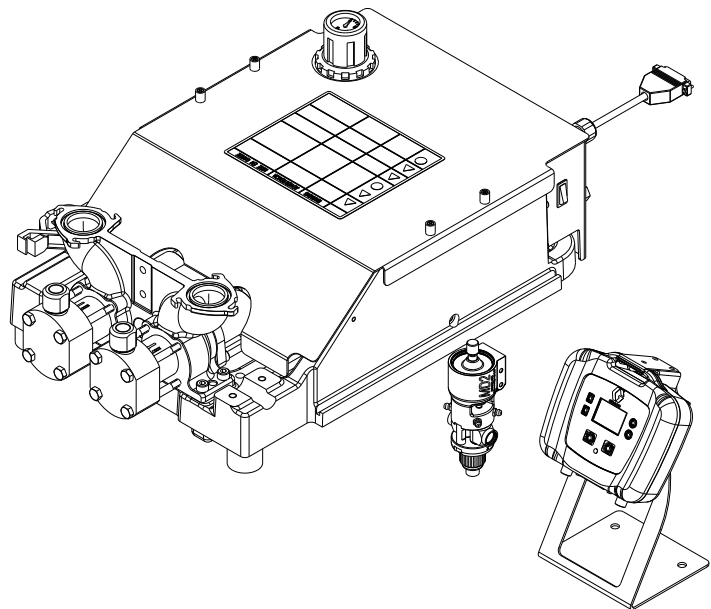

# Contents

<b>Models</b> .....	<b>3</b>	<b>Repair</b> .....	<b>40</b>
<b>Related Manuals</b> .....	<b>3</b>	HydraCheck Kit Installation, 24W336 .....	40
<b>Warnings</b> .....	<b>4</b>	Air Cylinder Rebuild Instructions .....	42
Moisture Sensitivity of Isocyanates .....	6	Rear Pump Rebuild Instructions .....	44
<b>Component Identification</b> .....	<b>7</b>	Piston/Cylinder Replacement Kit Installation ...	46
Machine .....	7	Check Valve Rebuild Kit Installation .....	47
Local Control Module (LCM) .....	8	<b>Parts</b> .....	<b>48</b>
LCM Screen Navigation .....	9	Fixed Ratio Base .....	48
<b>Recommended Parts</b> .....	<b>10</b>	Pump Sub-Assembly, 24S053 .....	50
Dispense Valve .....	10	Fixed Ratio Drive Block Assembly, LC0107 ...	52
Mixers .....	12	Air Cylinder, 24V933 and 24V934 .....	53
Applicator Mounting .....	14	Fixed Ratio Frame Sub-Assembly, LC0290 ...	54
Air Filter and Ball Valve, 24R707 .....	15	<b>Schematics</b> .....	<b>56</b>
High Temperature Grease, 115982 .....	15	Electrical Schematics .....	56
Footswitch, 255244 .....	15	Pneumatic Schematic .....	58
Tanks .....	16	<b>Appendix A - LCM Icon Overview</b> .....	<b>60</b>
Hose Packages .....	18	<b>Appendix B - LCM Run Screen Overview</b> .....	<b>62</b>
Piston Package .....	20	<b>Appendix C - LCM Setup Screen Overview</b> .....	<b>64</b>
<b>Pump Tube Combination Information</b> .....	<b>22</b>	<b>Kits</b> .....	<b>65</b>
<b>Installation</b> .....	<b>23</b>	Nylon and UHMW Piston Replacement Kits ...	65
Grounding .....	23	<b>Kits</b> .....	<b>66</b>
Machine Installation .....	23	<b>Dimensions</b> .....	<b>67</b>
<b>Setup</b> .....	<b>26</b>	<b>Technical Data</b> .....	<b>68</b>
Piston Position Calibration .....	26	<b>Graco Standard Warranty</b> .....	<b>70</b>
Prime the Dispense Head .....	28	<b>Graco Information</b> .....	<b>70</b>
Phasing Adjustment .....	29		
Adjust Dispense Valve Snuff Back .....	31		
Adjust Open Dispense Valve (ODV) Timing ...	32		
<b>Operation</b> .....	<b>33</b>		
Startup .....	33		
Pressure Relief			
Procedure .....	33		
Shutdown .....	34		
<b>Maintenance</b> .....	<b>35</b>		
Schedule .....	35		
Clean the Pump Shafts .....	35		
Disassemble and Clean the Dispense Head ...	35		
Install Upgrade Token .....	36		
<b>Troubleshooting</b> .....	<b>37</b>		
LCM Error Codes .....	39		

## Models









System	MD2 Valve Ratio	Air Motor in. (cm)	Required Line Voltage	Machine Operation Voltage	Maximum Working Pressure psi (MPa, bar)	Maximum Air Inlet Pressure psi (MPa, bar)
24S054	1:1	3 (7.6)	100-240 V 50/60 Hz, 1 phase - 50 Watts	24 VDC	3000 (21, 207)	100 (0.7, 7)
24S055	10:1					
24S056	1:1	4.5 (11.4)				
24S057	10:1					

## Related Manuals

MD2 Dispense Valve Manual	
Part	Description
312185	MD2 Valve, Instructions
312394	PR70™ and PR70v™ Feed Systems, Instructions-Parts
312761	PR70™ and PR70v™ Integrated Heat Instructions-Parts Manual
3A8824	PR70™ and PR70v™ ISO Lube Recirculation Kits Instructions-Parts Manual

# Warnings

The following warnings are for the setup, use, grounding, maintenance, and repair of this equipment. The exclamation point symbol alerts you to a general warning and the hazard symbols refer to procedure-specific risks. When these symbols appear in the body of this manual or on warning labels, refer back to these Warnings. Product-specific hazard symbols and warnings not covered in this section may appear throughout the body of this manual where applicable.

 <b>WARNING</b>	
 	<p><b>ELECTRIC SHOCK HAZARD</b></p> <p>This equipment must be grounded. Improper grounding, setup, or usage of the system can cause electric shock.</p> <ul style="list-style-type: none"> <li>• Turn off and disconnect power cord before servicing equipment.</li> <li>• Connect only to grounded electrical outlets.</li> <li>• Ensure ground prongs are intact on power and extension cords.</li> <li>• Do not expose to rain. Store indoors.</li> </ul>
  	<p><b>SKIN INJECTION HAZARD</b></p> <p>High-pressure fluid from dispensing device, hose leaks, or ruptured components will pierce skin. This may look like just a cut, but it is a serious injury that can result in amputation. <b>Get immediate surgical treatment.</b></p> <ul style="list-style-type: none"> <li>• Do not point dispensing device at anyone or at any part of the body.</li> <li>• Do not put your hand over the fluid outlet.</li> <li>• Do not stop or deflect leaks with your hand, body, glove, or rag.</li> <li>• Follow the <b>Pressure Relief Procedure</b> when you stop dispensing and before cleaning, checking, or servicing equipment.</li> <li>• Tighten all fluid connections before operating the equipment.</li> <li>• Check hoses and couplings daily. Replace worn or damaged parts immediately.</li> </ul>
	<p><b>TOXIC FLUID OR FUMES HAZARD</b></p> <p>Toxic fluids or fumes can cause serious injury or death if splashed in the eyes or on skin, inhaled, or swallowed.</p> <ul style="list-style-type: none"> <li>• Read MSDSs to know the specific hazards of the fluids you are using.</li> <li>• Store hazardous fluid in approved containers, and dispose of it according to applicable guidelines.</li> </ul>
	<p><b>PERSONAL PROTECTIVE EQUIPMENT</b></p> <p>Wear appropriate protective equipment when in the work area to help prevent serious injury, including eye injury, hearing loss, inhalation of toxic fumes, and burns. This protective equipment includes but is not limited to:</p> <ul style="list-style-type: none"> <li>• Protective eyewear, and hearing protection.</li> <li>• Respirators, protective clothing, and gloves as recommended by the fluid and solvent manufacturer.</li> </ul>

# ! WARNING



## FIRE AND EXPLOSION HAZARD

Flammable fumes, such as solvent and paint fumes, in **work area** can ignite or explode. To help prevent fire and explosion:

- Use equipment only in well ventilated area.
- Eliminate all ignition sources; such as pilot lights, cigarettes, portable electric lamps, and plastic drop cloths (potential static arc).
- Keep work area free of debris, including solvent, rags and gasoline.
- Do not plug or unplug power cords, or turn power or light switches on or off when flammable fumes are present.
- Ground all equipment in the work area. See **Grounding** instructions.
- Use only grounded hoses.
- Hold gun firmly to side of grounded pail when triggering into pail. Do not use pail liners unless they are antistatic or conductive.
- **Stop operation immediately** if static sparking occurs or you feel a shock. Do not use equipment until you identify and correct the problem.
- Keep a working fire extinguisher in the work area.



## EQUIPMENT MISUSE HAZARD

Misuse can cause death or serious injury.

- Do not operate the unit when fatigued or under the influence of drugs or alcohol.
- Do not exceed the maximum working pressure or temperature rating of the lowest rated system component. See **Technical Data** in all equipment manuals.
- Use fluids and solvents that are compatible with equipment wetted parts. See Technical Data in all equipment manuals. Read fluid and solvent manufacturer's warnings. For complete information about your material, request MSDS from distributor or retailer.
- Do not leave the work area while equipment is energized or under pressure.
- Turn off all equipment and follow the **Pressure Relief Procedure** when equipment is not in use.
- Check equipment daily. Repair or replace worn or damaged parts immediately with genuine manufacturer's replacement parts only.
- Do not alter or modify equipment. Alterations or modifications may void agency approvals and create safety hazards.
- Make sure all equipment is rated and approved for the environment in which you are using it.
- Use equipment only for its intended purpose. Call your distributor for information.
- Route hoses and cables away from traffic areas, sharp edges, moving parts, and hot surfaces.
- Do not kink or over bend hoses or use hoses to pull equipment.
- Keep children and animals away from work area.
- Comply with all applicable safety regulations.



## MOVING PARTS HAZARD

Moving parts can pinch, cut or amputate fingers and other body parts.

- Keep clear of moving parts.
- Do not operate equipment with protective guards or covers removed.
- Pressurized equipment can start without warning. Before checking, moving, or servicing equipment, follow the **Pressure Relief Procedure** and disconnect all power sources.

## Moisture Sensitivity of Isocyanates

Isocyanates (ISO) are catalysts used in two component foam and polyurea coatings. ISO will react with moisture (such as humidity) to form small, hard, abrasive crystals, which become suspended in the fluid. Eventually a film will form on the surface and the ISO will begin to gel, increasing in viscosity. If used, this partially cured ISO will reduce performance and the life of all wetted parts.

**NOTE:** The amount of film formation and rate of crystallization varies depending on the blend of ISO, the humidity, and the temperature.

To prevent exposing ISO to moisture:

- Always use a sealed container with a desiccant dryer in the vent, or a nitrogen atmosphere. **Never** store ISO in an open container.
- The PR70 has exposed shafts, so extra precautions must be taken when using ISO Materials. Make sure that the shafts are wiped clean and lubricated if sitting unused for any length of time, such as overnight shutdowns. The lubricant creates a barrier between the ISO and the atmosphere. Evaluate your system and follow this procedure more often if necessary.
- Use moisture-proof hoses specifically designed for ISO, such as those supplied with your system.
- Never use reclaimed solvents, which may contain moisture. Always keep solvent containers closed when not in use.
- Never use solvent on one side if it has been contaminated from the other side.
- Always lubricate threaded parts with ISO pump oil or grease when reassembling.

# Component Identification

## Machine

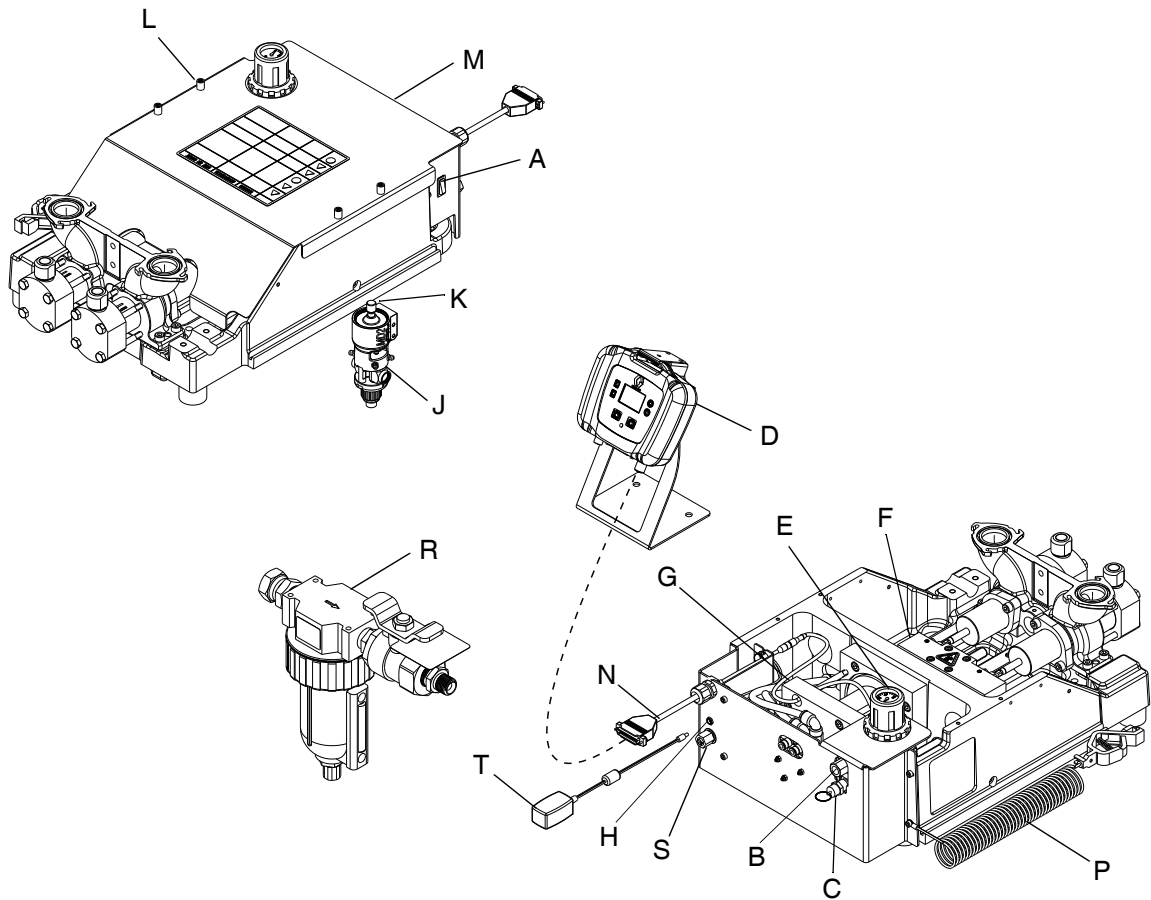

**FIG. 1: Machine**

**Key:**

A	Power Switch	N	Control Cable
B	Air Inlet	P	Ground Wire and Clamp
C	System Air Pressure Relief Valve	R	Air/Water Separator Assembly with Vented Ball Valve (Not Supplied - 24R707)
D	Local Control Module (LCM)	S	Footswitch Connection
E	Air Pressure Regulator	T	24V Power Supply
F	Drive Block		
G	Air Motor		
H	24V Power Input		
J	Dispense Head		
K	Snuff Back Adjustment Knob		
L	Machine Shield Screws		
M	Machine Shield		

## Local Control Module (LCM)

### NOTICE

To prevent damage to soft key buttons, do not press the buttons with sharp object such as pens, plastic cards, or fingernails.

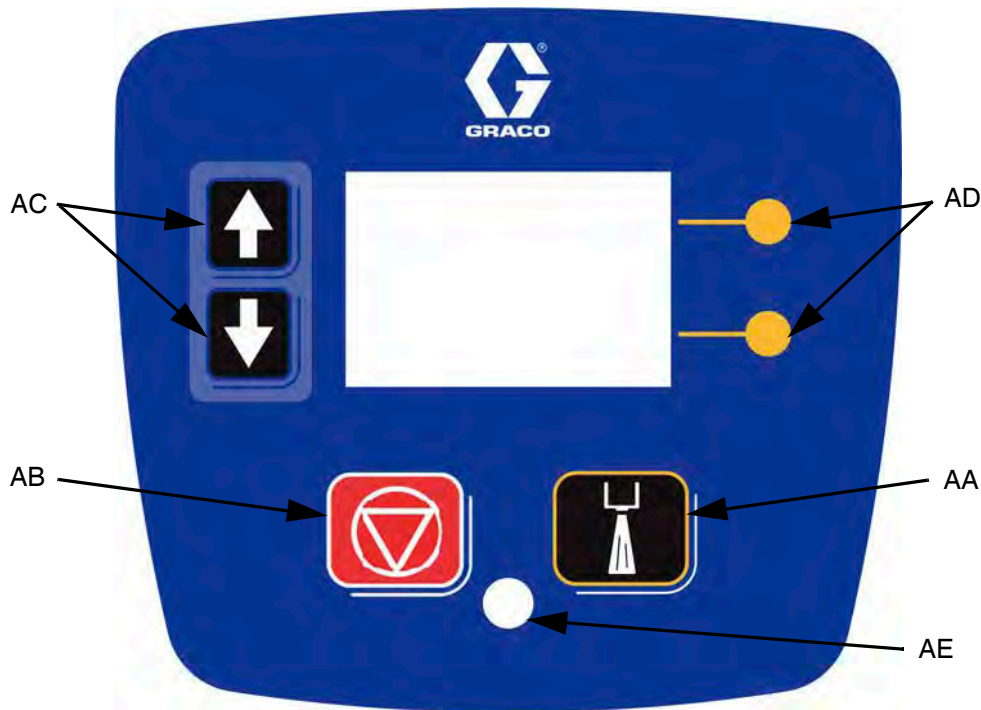

FIG. 2: LCM

### Key:

#### AA Dispense Request or “Go” key

This key will dispense material and can not be disabled by the user as a setup screen option.

#### AB System Shut-Down Key

This key will disable the machine (all outputs de-energized) and will place the machine in disable mode. This key is always active.

#### AC Up and Down Navigation Arrow Keys

Used to navigate between screens, navigate within a screen, used for numerical entry or used to select features.

#### AD Soft Key Inputs

Function of the keys will reflect the graphic provided to the left of the respective key.

#### AE Status LED

*Solid* - System is ready and operational.

*Continuous Flashing* - System is starting up or system is being programmed.

*Continuous Flashing with Pause* - Indicates an error is active. Refer to **LCM Error Codes**, page 39.

*Flash Once with Pause* - System is inactive.



# LCM Screen Navigation

For screen overview, refer to **Appendix B - LCM Run Screen Overview** and **Appendix C - LCM Setup Screen Overview** starting on page 62.

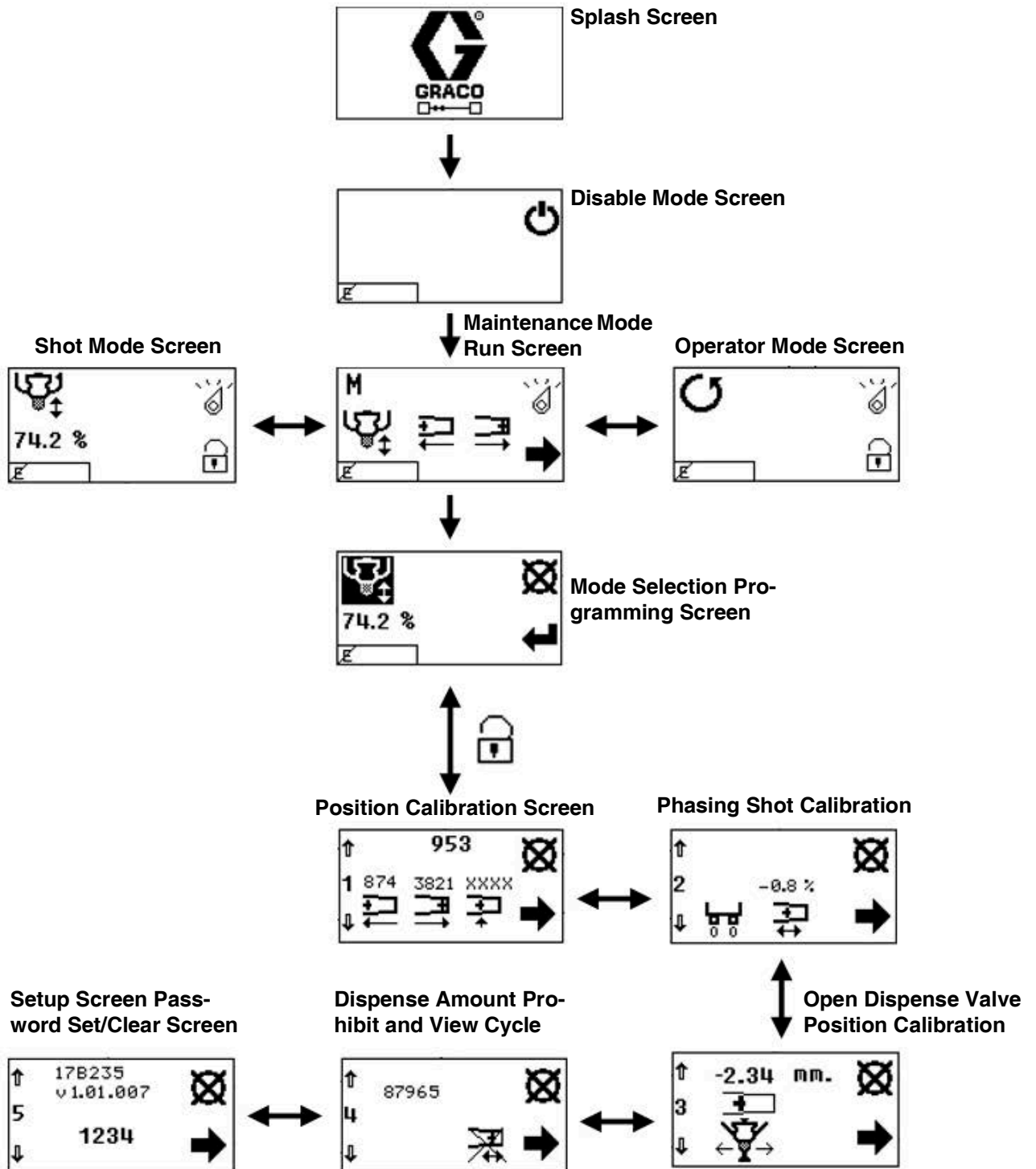

# Recommended Parts

## Dispense Valve

### Standard Dispense Valves, 255179 and 255181

See MD2 manual for parts information.

### Gun Mounted MD2 Valves, LC0120 and LC0122

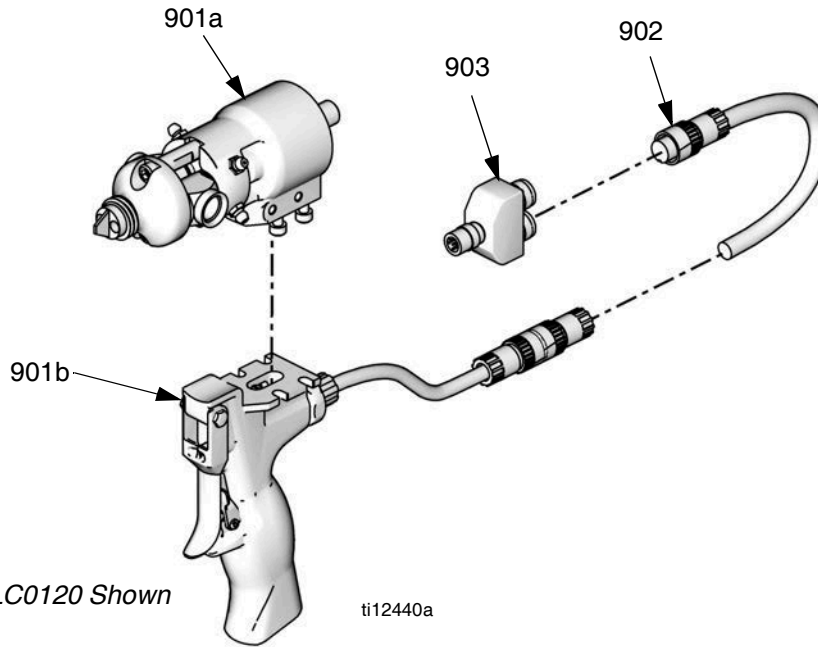

Ref	Part	Description	Quantity
901	LC0006	VALVE, assembly, 10:1, gun, electric (assembly LC0122 only)	1
	LC0004	VALVE, assembly, 1:1, gun, electric (assembly LC0120 only)	1
901a	255181 †	VALVE, dispense, 10:1, soft seats (assembly LC0122 only)	1
	255179 †	VALVE, dispense, 1:1, soft seats (assembly LC0120 only)	1
901b	255208	HANDLE, 2K dispense valve, electric	1
902	121198	CORD, euro, male, 4 pin, 3 wire, 6 m (Series A Handles only)	1
	123660	CORD, euro, male/female, 6 m (Series B Handles only)	1
903	120953	CONNECTOR, splitter	1

† See MD2 manual for dispense valve and dispense valve handle parts information.

## Lever Actuated MD2 Valves, LC0121 and LC0123

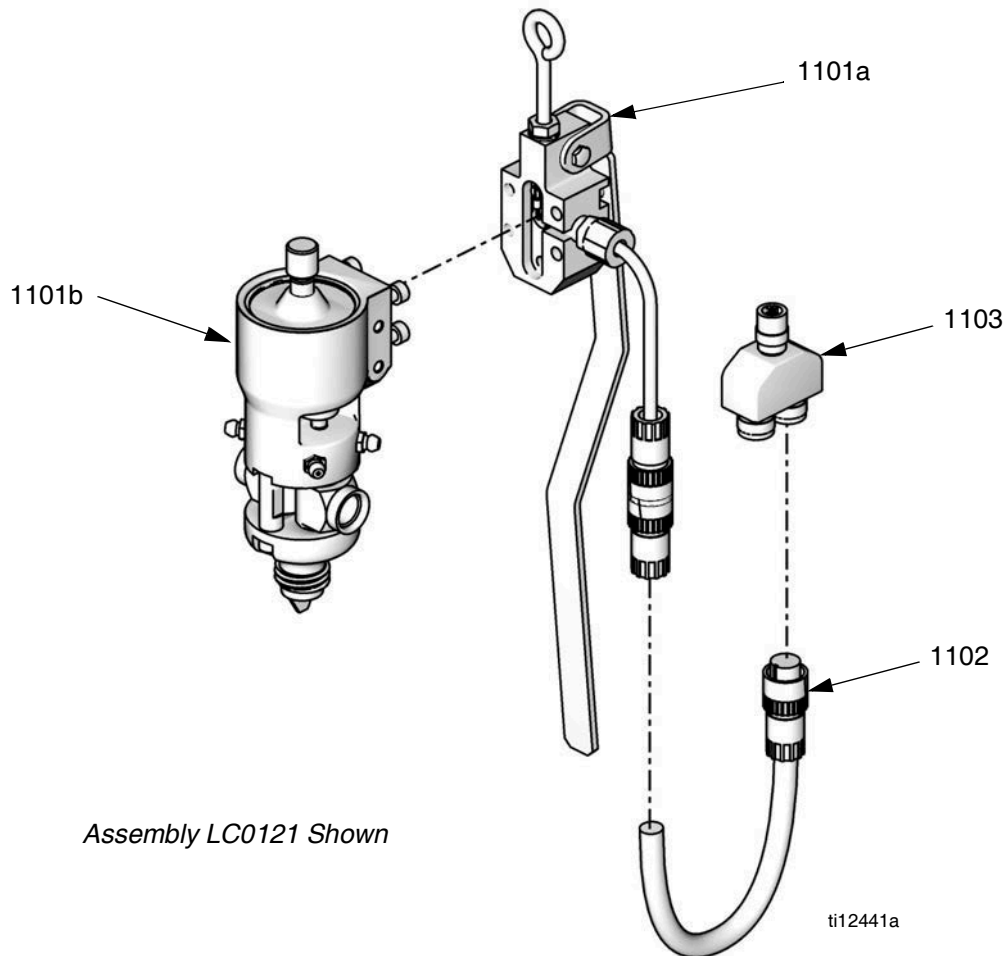

Ref	Part	Description	Quantity
1101	LC0005	VALVE, assembly, 1:1, lever, electric (assembly LC0121 only)	1
	LC0007	VALVE, assembly, 10:1, lever, electric (assembly LC0123 only)	1
1101a	255249	LEVER, 2K dispense valve	1
1101b	255181 †	VALVE, dispense, 10:1, soft seats (assembly LC0123 only)	1
	255179 †	VALVE, dispense, 1:1, soft seats (assembly LC0121 only)	1
1102	121198	CORD, euro, male, 4 pin, 3 wire, 6 m (Series A Handles only)	1
	123660	CORD, euro, male/female, 6 m (Series B Handles only)	1
1103	120953	CONNECTOR, splitter	1

† See MD2 manual for dispense valve and dispense valve lever parts information.

# Mixers

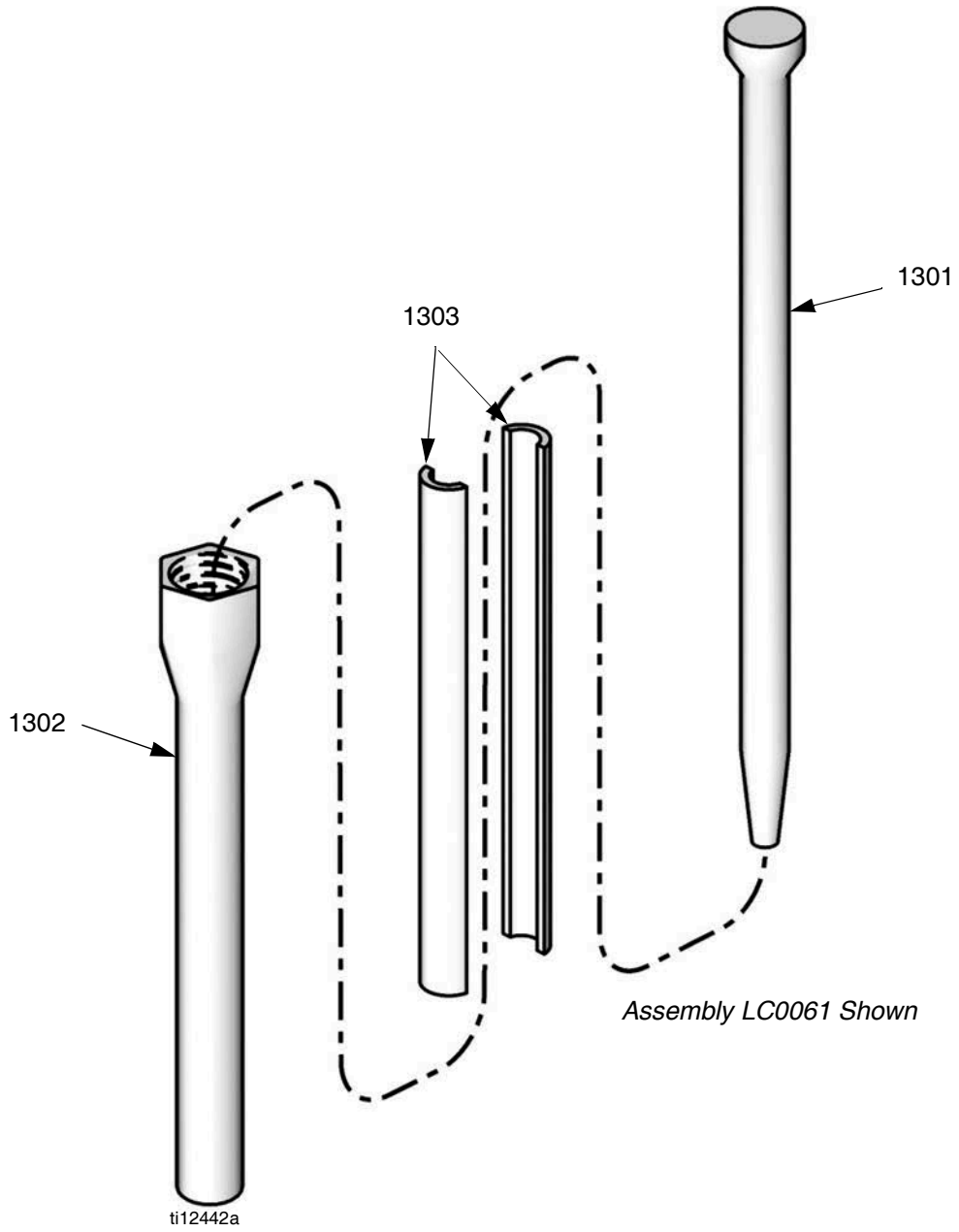

Mixer Package	Description	Reference Number and Description		
		1301	1302	1303
		Mixer Part No. (Quantity)	Shroud Part No. (Quantity 1)	Sleeve Part No. (Quantity 1)
LC0063	3/16 in. x 32	60/0206/50 (10)	94/0884-1/98	---
LC0077	3/16 in. x 32	60/0206/50 (50)	---	---
LC0084	3/16 in. x 32	60/0206/50 (250)	---	---
LC0061	3/16 in. x 32 Luer Lock	16D012 (10)	16P448	60/0313/97
LC0082	3/16 in. x 32 Luer Lock	16D012 (50)	---	---
LC0089	3/16 in. x 32 Luer Lock	16D012 (250)	---	---
LC0057	1/4 in. X 24	60/0204/50 (10)	16P445	---
LC0078	1/4 in. x 24	60/0204/50 (50)	---	---
LC0085	1/4 in. x 24	60/0204/50 (250)	---	---
LC0062	1/4 in. x 24 Luer Lock	60/0209/50 (10)	94/0883-M/98	60/0305/97
LC0083	1/4 in. x 24 Luer Lock	60/0209/50 (50)	---	---
LC0090	1/4 in. x 24 Luer Lock	60/0209/50 (250)	---	---
LC0058	3/8 in. x 24	60/0200/50 (10)	16P446	---
LC0079	3/8 in. x 24	60/0200/50 (50)	---	---
LC0086	3/8 in. x 24	60/0200/50 (250)	---	---
LC0059	3/8 in. x 36	60/0201/50 (10)	16P447	---
LC0080	3/8 in. x 36	60/0201/50 (50)	---	---
LC0087	3/8 in. x 36	60/0201/50 (250)	---	---
LC0060	3/8 in. combo	60/0202/50 (10)	16P447	---
LC0081	3/8 in. combo	60/0202/50 (50)	---	---
LC0088	3/8 in. combo	60/0202/50 (250)	---	---
LC0295	1/2 in. x 24	60/0111-1/50 (10)	94/0885-24/98	---
LC0296	1/2 in. x 36	60/0117-1/50 (10)	94/0885-36/98	---

# Applicator Mounting

**Mast Mount, Controls and MD2 Applicator, LC0292**  
**Mast Mount, Controls only, LC0293**

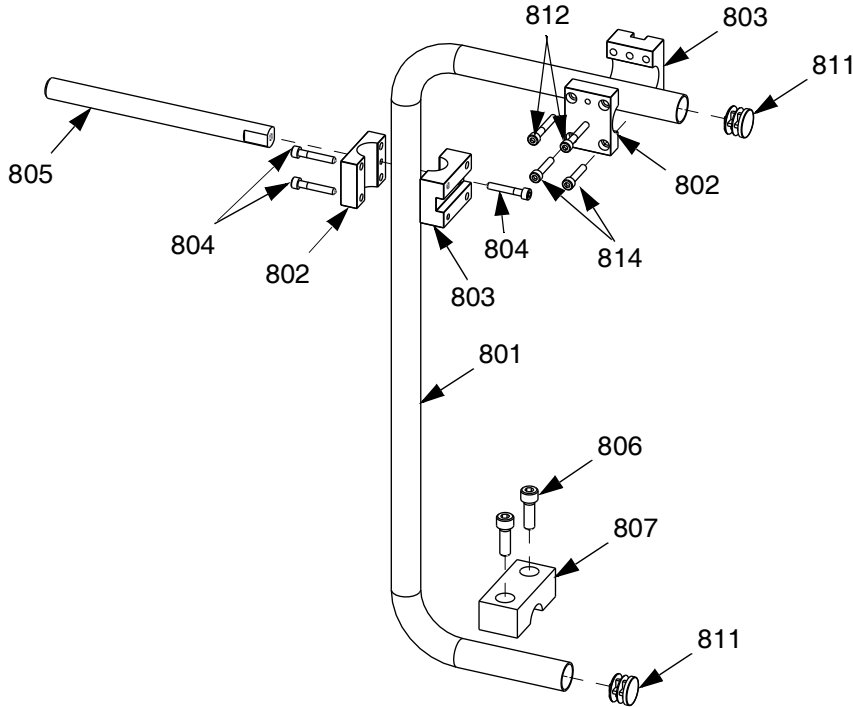

Ref	Part	Description	Quantity	
			LC0292, BRACKET, mounting, valve, HMI	LC0293, BRACKET, mounting, HMI
801	16P082	BASE, arm, mounting	1	1
802	16P409	BLOCK, mounting, front	2	1
803	16P550	BLOCK, mounting, rear	2	1
804	121194	SCREW	3	3
805	15K832	ARM, mounting, HMI	1	1
806	120913	SCREW	2	2
807	15M658	CLAMP	1	1
809*	121046	TUBE, 1/4 x 1/4 twin, polyurethane	6	6
810*	94/0705-1/96	FITTING, elbow, swivel	2	2
811	126510	PLUG, round, finishing	2	2
812	121273	SCREW, socket head	2	
814	121013	SCREW, socket head	2	

\* Not shown.

## Air Filter and Ball Valve, 24R707

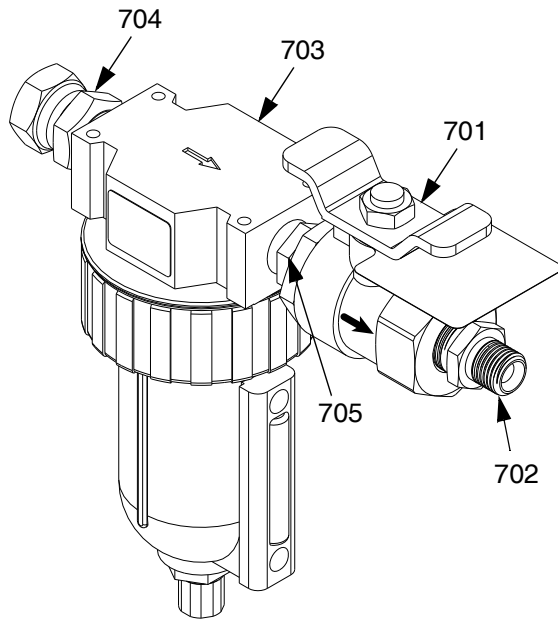

Ref	Part	Description	Quantity
701	---	VALVE, vented 2 way	1
702	157350	ADAPTER	1
703	106148	FILTER, air, 3/8 NPT	1
704	155665	UNION, adapter	1
705	---	NIPPLE, pipe	1

## High Temperature Grease, 115982

## Footswitch, 255244

## Tanks

1 1/2 in. NPT Flanges, 24W417

8 Liter, Twin Polyethylene Tanks and Lids, 24W415

8 Liter, Twin Polyethylene Tanks and Lids, with Shut-Off Valves, 24W416

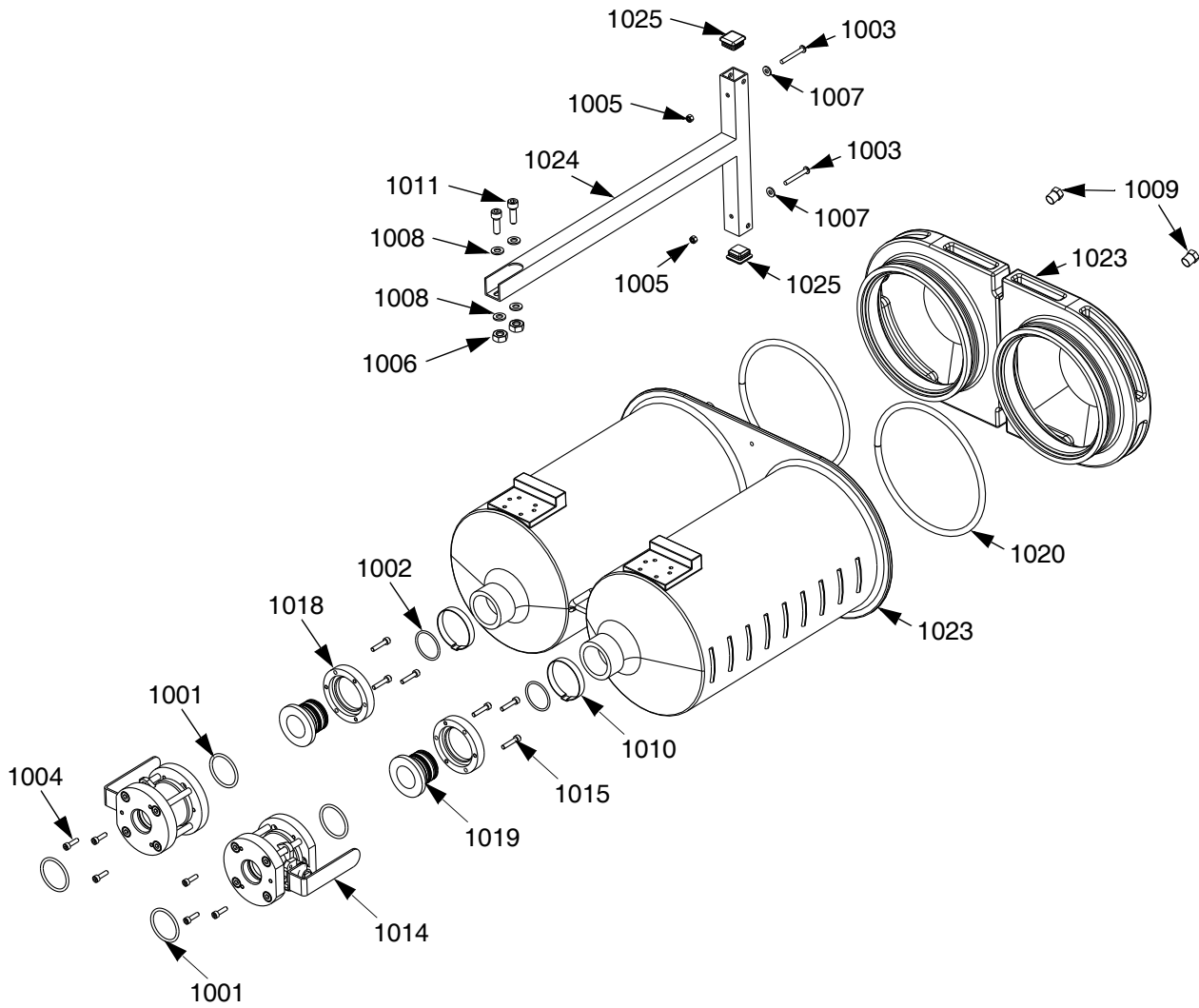



Ref	Part	Description	Quantity		
			24W415	24W416	24W417
1001	95/0223/00	O-RING	2	4	1
1002	120901	O-RING	4	4	
1003	120902	SCREW, M5x40mm	2	2	
1004	120904	SCREW, M5x18mm	6	6	3
1005	120905	NUT, hex, lock M5	2	2	
1006	120906	NUT, hex, lock M8 x 1.25	2	2	
1007	120907	WASHER, plain #10	4	2	
1008	120908	WASHER, plain M8	4	4	
1009	120909	BREATHER	2	2	
1010	120911	CLAMP, gap-free pinch hose	2	2	
1011	120913	SCREW	2	2	
1014	255280	VALVE, ball		2	
1015	121013	SCREW, M5x25mm		6	
1018	---	RING, lock	2	2	
1019	---	FITTING, flange	2	2	
1020	15K840	O-RING	2	2	
1023	---	TANK, 8 liter	1	1	
1024	15M226	BALLAST		1	
	15K842	BALLAST	1		
1025	120915	CAP PLUG, square	2	2	
1026*	15M237	FLANGE, 1-1/2 in. NPT			1

\* Not Shown

# Hose Packages

## Unheated, Non-Recirculating Hose

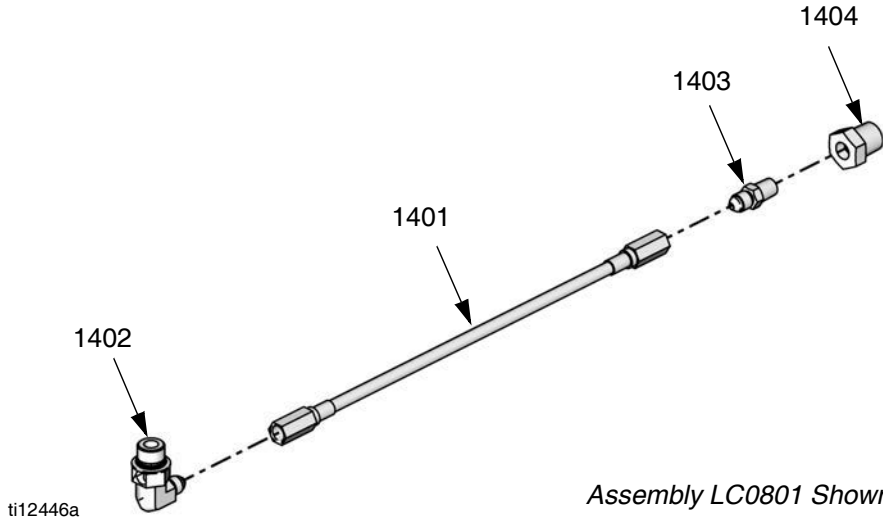

Apply thread sealant tape to male npt threads before assembly.

Hose Package	Description	Reference Number and Description			
		1401 Hose Assembly	1402 90 Deg Elbow	1403 Adapter	1404 Bushing
LC0801	3/16 in. x 30 in.	16C501	94/0144-S/25	94/1000/98	94/0488/98
LC0802	3/16 in. x 120 in.	16C506	94/0144-S/25	94/1000/98	94/0488/98
LC0803	3/16 in. x 180 in.	16C507	94/0144-S/25	94/1000/98	94/0488/98
LC0804	1/4 in. x 30 in.	16C510	94/0148-S/25	J6900040	
LC0805	1/4 in. x 120 in.	16C515	94/0148-S/25	J6900040	
LC0806	1/4 in. x 180 in.	16C516	94/0148-S/25	J6900040	
LC0807	3/8 in. x 30 in.	16C519	94/0149-S/25	94/1007/98	
LC0808	3/8 in. x 120 in.	16C524	94/0149-S/25	94/1007/98	
LC0809	3/8 in. x 180 in.	16C525	94/0149-S/25	94/1007/98	
LC0400*	3/8 in. x 30 in.	16D261	94/0149-S/25	94/1007/98	
LC0401*	3/8 in. x 120 in.	16D266	94/0149-S/25	94/1007/98	
LC0402*	3/8 in. x 180 in.	16D267	94/0149-S/25	94/1007/98	
LC0810	1/2 in. x 30 in.	16C529	94/0150-S/25	94/1009/98	
LC0811	1/2 in. x 120 in.	16C534	94/0150-S/25	94/1009/98	
LC0812	1/2 in. x 180 in.	16C535	94/0150-S/25	94/1009/98	
LC0403*	1/2 in. x 30 in.	16D271	94/0150-S/25	16C399	
LC0404*	1/2 in. x 120 in.	16D276	94/0150-S/25	16C399	
LC0405*	1/2 in. x 180 in.	16D277	94/0150-S/25	16C399	
LC0813	3/4 in. x 120 in.	16C544	94/0153-S/25	94/1083/98	
LC0814	3/4 in. x 180 in.	16C545	94/0153-S/25	94/1083/98	
LC0406*	3/4 in. x 120 in.	16D286	94/0153-S/25	94/1083/98	
LC0407*	3/4 in. x 180 in.	16D287	94/0153-S/25	94/1083/98	
<b>Quantity</b>		<b>1</b>	<b>1</b>	<b>1</b>	<b>1</b>

\* High pressure hoses (3500 psi, 24 MPa, 241 bar)



# Piston Package

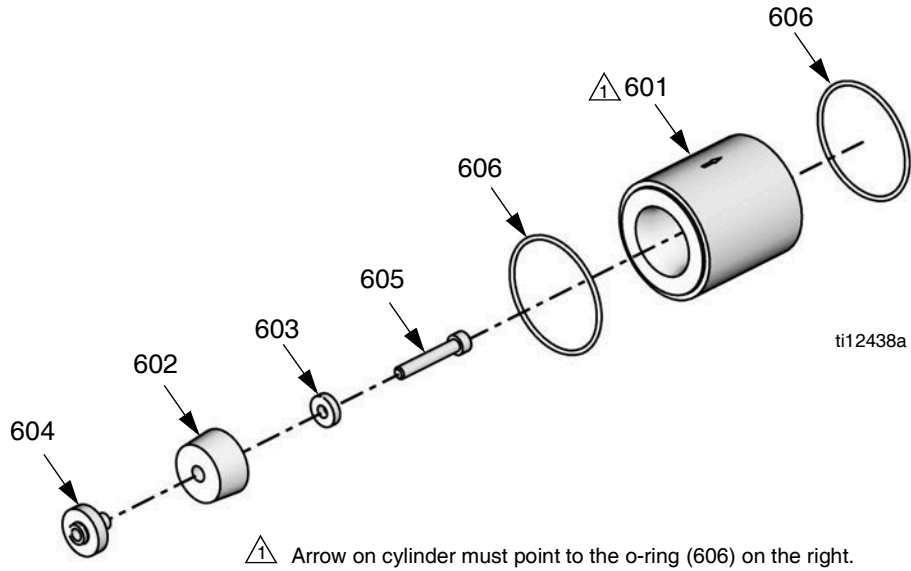

## Nylon Piston, Stainless Steel Metering Tube Assemblies

Piston Package	Reference Number and Description					
	601 Tube, pump	602 Nylon Piston	603† Washer	604 Ring, support, piston	605 Screw	606 O-ring
LC1080	LCC080	LCB080	15M089			
LC1100	LCC100	LCB100				
LC1120	LCC120	LCB120				
LC1140	LCC140	LCB140				
LC1160	LCC160	LCB160	15M099	15K887		
LC1180	LCC180	LCB180				
LC1200	LCC200	LCB200				
LC1220	LCC220	LCB220				
LC1240	LCC240	LCB240				
LC1260	LCC260	LCB260				
LC1280	LCC280	LCB280				
LC1300	LCC300	LCB300				
LC1320	LCC320	LCB320	15M100		120933	120874
LC1360	LCC360	LCB360				
LC1400	LCC400	LCB400				
LC1440	LCC440	LCB440				
LC1480	LCC480	LCB480				
LC1520	LCC520	LCB520				
LC1560	LCC560	LCB560				
LC1600	LCC600	LCB600				
LC1640	LCC640	LCB640	15M101	15K890		
LC1720	LCC720	LCB720				
LC1800	LCC800	LCB800				
LC1880	LCC880	LCB880				
LC1960	LCC960	LCB960				
<b>Quantity</b>	1	1	1	1	1	2

## UHMW Piston, Stainless Steel Metering Tube Assemblies

Piston Package	Reference Number and Description					
	601	602	603†	604	605	606
	Tube, pump	UHMW Piston	Washer	Ring, support, piston	Screw	O-ring
LC2160	LCC160	LCA160	15M099	15K887		
LC2180	LCC180	LCA180				
LC2200	LCC200	LCA200				
LC2220	LCC220	LCA220				
LC2240	LCC240	LCA240				
LC2260	LCC260	LCA260				
LC2280	LCC280	LCA280				
LC2300	LCC300	LCA300	15M100	15K888	120933	120874
LC2320	LCC320	LCA320				
LC2360	LCC360	LCA360				
LC2400	LCC400	LCA400				
LC2440	LCC440	LCA440				
LC2480	LCC480	LCA480				
LC2520	LCC520	LCA520				
LC2560	LCC560	LCA560				
LC2600	LCC600	LCA600				
LC2640	LCC640	LCA640				
LC2720	LCC720	LCA720	15M101	15K890		
LC2800	LCC800	LCA800				
LC2880	LCC880	LCA880				
LC2960	LCC960	LCA960				
<b>Quantity</b>	1	1	1	1	1	2

† For custom piston packages, washer (603) part number will change by piston size as follows:

For piston sizes 80-100cc: 15M089

For piston sizes 101-159cc: Washer not used.

For piston sizes 160-285cc: 15M099

For piston sizes 286-646cc: 15M100

For piston sizes 647-960cc: 15M101

# Pump Tube Combination Information

Pump Tube Combination Information					Power Factor	
Ratio (X:1)	Large Piston (mm)	Small Piston (mm)	Minimum Shot Size (cc)	Maximum Shot Size (cc)	3 in. Air Motor	4.5 in. Air Motor
1	960	960	12.4	71.0	2	5
1	640	640	8.3	47.3	4	8
1	480	480	6.2	35.5	5	11
1	320	320	4.1	23.7	7	16
1	240	240	3.1	17.7	10	21
1	160	160	2.1	11.8	14	✘
1	120	120	1.6	8.9	19	✘
1	80	80	1.0	5.9	29	✘
1.50	240	160	2.6	14.8	11	26
1.50	960	640	10.4	59.1	3	6
1.50	480	320	5.2	29.6	6	13
1.50	120	80	1.3	7.4	23	✘
2	960	480	9.3	53.2	3	7
2	640	320	6.2	35.5	5	11
2	480	240	4.7	26.6	6	14
2	320	160	3.1	17.7	10	21
2	240	120	2.3	13.3	13	29
2	160	80	1.6	8.9	19	✘
3	960	320	8.3	47.3	4	8
3	480	160	4.1	23.7	7	16
3	240	80	2.1	11.8	14	✘
4	960	240	7.8	44.3	4	9
4	640	160	5.2	29.6	6	13
4	480	120	3.9	22.2	8	17
4	320	80	2.6	14.8	11	26
5.33	640	120	4.9	28.1	6	14
6	960	160	7.3	41.4	4	9
6	480	80	3.6	20.7	8	18
8	960	120	7.0	39.9	4	10
8	640	80	4.7	26.6	6	14
10	800	80	5.7	32.5	5	12
12	960	80	6.7	38.4	4	10

✘ Pump tube combination is not recommended.

# Installation

## Grounding

--	--	--	--	--	--	--

The equipment must be grounded to reduce the risk of static sparking and electric shock. Electric or static sparking can cause fumes to ignite or explode. Improper grounding can cause electric shock. Grounding provides an escape wire for the electric current.

### General Grounding Guidelines

**Pump:** use ground wire and clamp (P). Refer to page 7 for component identification. Connect ground wire and clamp to a true earth ground.

**Fluid hoses:** use only electrically conductive hoses.

**Dispense Valve:** ground through a proper connection to a fluid hose and grounded pump.

**Fluid supply container:** follow local codes.

**Object being sprayed:** follow local codes.

**Solvent pails used when flushing:** follow local code. Use only conductive metal pails, placed on a grounded surface. Do not place the pail on a nonconductive surface, such as paper or cardboard, which interrupts grounding continuity.

## Machine Installation

--	--	--	--	--	--	--

Pump shaft, polyethylene (PE) tank lid, and PE tank lid gasket are coated with Krytox grease. Wear protective gloves and cover exposed skin to avoid possible skin irritation on contact. Read Krytox MSDS to know the specific hazards, and follow manufacturer's warnings.

### Locate Machine

1. Locate a bench top or open floor area to mechanically mount the machine. Ensure the location has access to compressed air and AC power and is well ventilated.
2. Place the machine on the designated location. Allow the machine to rest on the rubber feet provided.

### Mount Machine, if Needed

3. Remove the shield locking screws on both sides, then remove the protective shield.
4. Attach the frame to the selected location by installing fasteners (not provided with unit) through the two mounting holes. See FIG. 3.

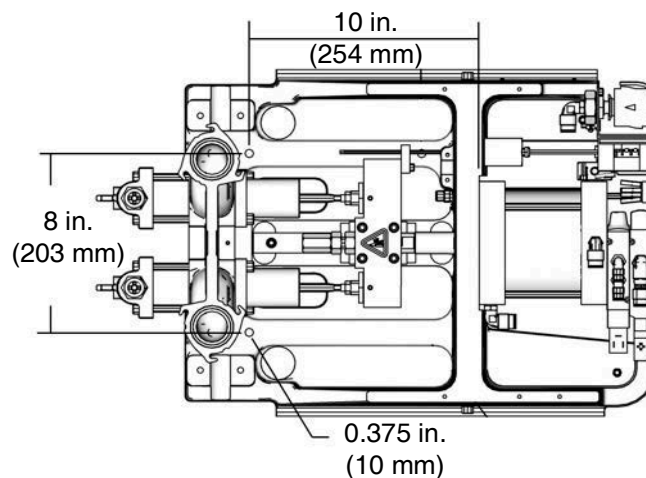
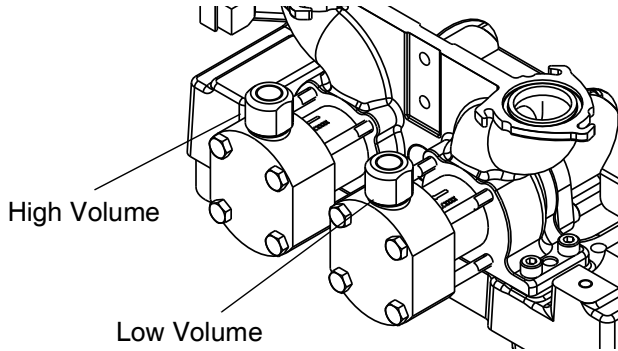

**FIG. 3: Mounting Holes**

### Install Pump Tubes

See **Piston Package** on page 20 and **Nylon and UHMW Piston Replacement Kits** on page 65 for kit numbers.

**NOTE:** Ensure that high volume and low volume pump tubes are installed on the correct side of the machine.



5. Secure the piston support ring, piston, and washer to the piston shaft using the piston screw. Tighten the piston screw until the screw stops rotating, then turn the screw an additional 1/8 turn.

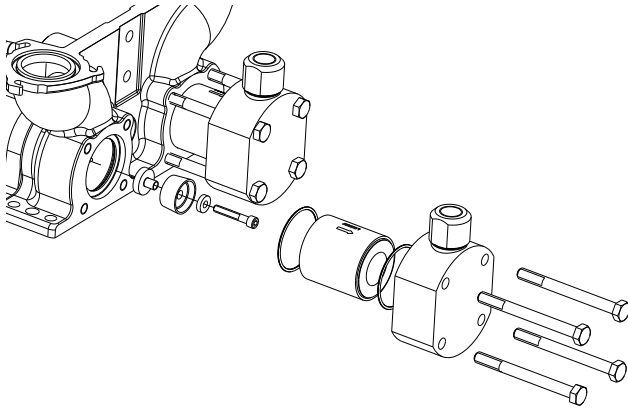

6. Lubricate the tube pump o-rings. Install the tube pump and o-rings as shown.

7. Install the pump cap onto the assembly using the four bolts. Finger tighten the bolts, then torque the bolts to 350 in-lb (40 N•m) in a crisscross pattern.

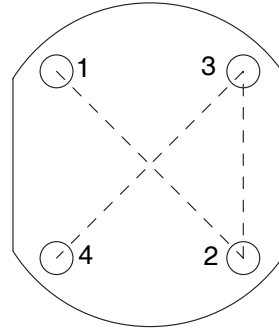

### Install the Chemical Hoses.

Install the chemical hoses and tighten to prevent leaks.

**NOTE:** Ensure that high volume and low volume hoses are installed on the correct side of the machine.

### Install the Hydracheck Kit.

Perform **HydraCheck Kit Installation, 24W336** starting on page 40.

### Install the Tanks.

Refer to the PR70 and PR70v Feed Systems, Instructions-Parts manual for details.

### Install the Dispense Valve and Support Arm, if needed.

Install the dispense valve as necessary to prevent movement. Connect the required air lines from the dispense valve to the machine.

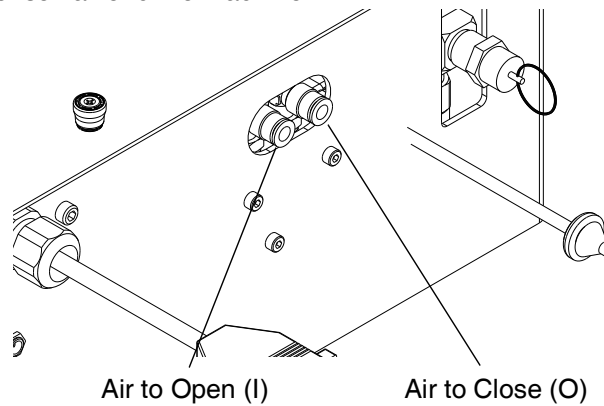



**Connect the Footswitch or External Device.**

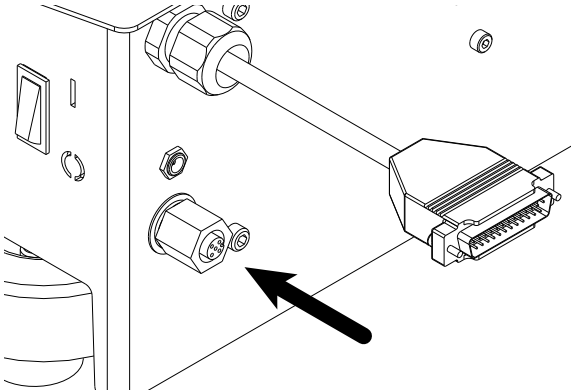

**Connect Pressurized Air Input**

8. Install an air inlet bleeding ball valve and air filter kit (not provided with unit, but available as kit 24R707) at the 1/4 NPT female air inlet.

**NOTICE**

The system must have a bleed-type ball valve that bleeds pressure downstream when closed. Otherwise, the supplied air will need to be disconnected from the system whenever the pressure is relieved.

**NOTE:** The system must use an air filter with a minimum flow rate of 30 scfm.

9. Close the ball valve.

**NOTE:** Air supply pressure must be between 80 psi (550 kPa, 5.5 bar) and 100 psi (690 kPa, 6.9 bar). Recommended pressure is 100 psi (690 kPa, 6.9 bar).

**Ground System**



The equipment must be grounded to reduce the risk of static sparking. Static sparking can cause fumes to ignite or explode. Grounding provides an escape wire for the electric current.

10. Follow **Grounding** instructions on page 23.

**Electrical Requirements**

11. Connect AC power (100-240V, 50/60 Hz, single-phase) to the power supply provided. Connect the power supply to the machine as shown.

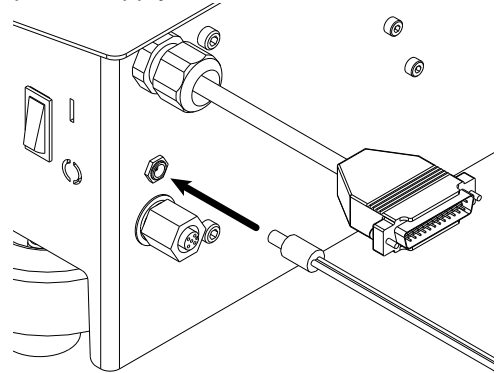

# Setup

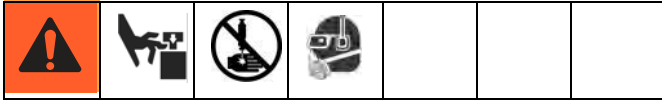

Before setting up the machine, the user needs to be familiar with the LCM screens. Refer to **Appendix A - LCM Icon Overview** and **Appendix B - LCM Run Screen Overview**, starting on page 60.

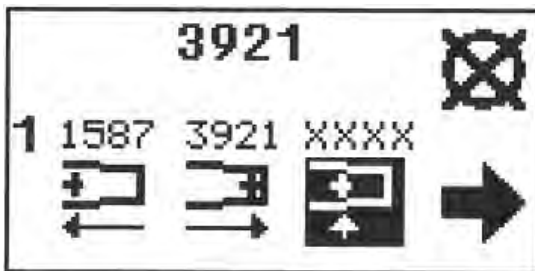

Perform **Startup**, page 33, to access the LCM screens.

## Piston Position Calibration



**Fig. 4: Position Calibration Screen**

The position sensor assigns a numeric value to the location of the piston. Higher numbers indicate the piston is more extended and lower numbers indicate the piston is more retracted.

The Piston Position Calibration procedure teaches the machine the location of the most extended piston position (  ), the most retracted piston position (  ), and the position where the piston engages the pump cylinder (  ).

Perform the **Piston Position Calibration** procedure when first setting up the machine. Also perform this procedure if the linear position sensor, piston, or any electronic component has been replaced. Press the Setup





Screen button (  ) to enter the setup screens.

### Prepare Machine for Calibration



1. Ensure that both piston shafts are screwed all the way into the drive block.
2. Navigate to the **Position Calibration Screen**.

3. Place a waste container under the dispense valve to capture any dispensed material.
4. Ensure the system air pressure is on by opening the vented ball valve and the system air pressure regulator shows air pressure in the system.



### Retracted Piston Position

5. With air pressure applied to the machine, high light the Retract Piston button (  ).
6. Press the Dispense Request button (  ). The piston will fully retract and a number from 1250 to 1700 will be displayed next to the Retract Piston button. If a number outside of this range is displayed, ensure the air cylinder air line connections are not switched and that the linear position sensor is properly installed.
7. Press the Enter button (  ) to accept the value or press the Abort/Cancel button (  ) to keep the previous value.





### Extended Piston Position

8. With air pressure applied to the machine, high light the Extend Piston button (  ).
9. Press the Dispense Request button (  ). The piston will fully extend and a number 3600-4000 should be displayed. If a number outside of this range is displayed, ensure the air cylinder air line connections are not switched and that the linear position sensor is installed correctly.

**NOTE:** If the piston does not extend after pressing the Dispense Request button (  ) the air pressure may need to be increased. Use system air pressure regulator to increase the air pressure in increments of 10 psi until the piston activates. Material will be dispensed when adequate pressure is achieved.

- Press the Enter button (  ) to accept the new value or press the Abort/Cancel button (  ) to keep the previous value. The screen should appear similar to FIG. 4 when done.

**Engaged Piston Position**



- Retract the pumps by highlighting the Retract Piston button (  ), then pressing the Dispense Request button (  ). After the pump retracts, press the Abort/Cancel button (  ).
- Close the vented ball valve to eliminate the air pressure to the system.
- High light the metering tube entrance position button (  ).
- With no air pressure in the system, press the Dispense Request button (  ).
- Move the piston drive block until it just begins to engage the cylinder using one of the following methods. No material should be dispensed.

**Manually Move the Piston Drive Block**

						
In the steps below, ensure pressure is off or piston may activate and pinch fingers against machine block.						

- Perform **Pressure Relief Procedure** on page 33.
- Remove the machine cover.
- With no air pressure in the system, manually push the piston drive block until the piston engages the cylinder and resists movement. A number from 2000 to 2650 will be displayed.

**NOTE:** If a number outside of this range is displayed, ensure the air cylinder air line connections are not switched and that the linear position sensor is properly installed.

- Ensure there is no material in the waste container under dispense valve. The piston block moved too far and caused material to be dispensed if there is material in the waste container. Go back to step 15 if the piston moved too far.
- Press the Enter button (  ) to accept the value or press the Abort/Cancel button (  ) to keep the previous value.
- When done, values similar to those shown in FIG. 5 should appear.

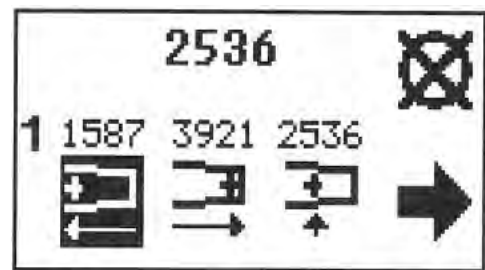





FIG. 5

**Prepare Machine for Operation**

- High light the Retract Piston button (  ).
  - Press the Dispense Request button (  ).
  - Open the vented ball valve to enable system pressure.
- |  |  |  |  |  |  |  |
|--|--|--|--|--|--|--|
|                                     |  |  |  |  |  |  |
| The piston will fully retract when the system is pressurized. To avoid injury, ensure the machine shield is installed. |  |  |  |  |  |  |
- Adjust the system air pressure regulator to increase air pressure to standard operating pressure for your application.
  - Navigate to the **Shot Mode Screen** or **Operator Mode Screen**.

## Prime the Dispense Head



### NOTICE

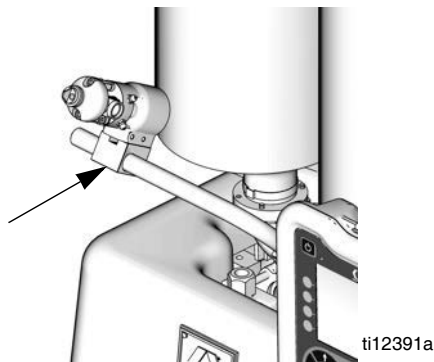

If the dispense head is not primed, chemical cross-over may occur resulting in cured material in the dispense head, hoses, and/or pumps.

1. Remove static mixer from the dispense head if installed.
2. Turn snuff-back adjustment knob fully clockwise. This will prevent the dispense valve from closing between priming shots.
3. Use a 4 mm hex key to loosen the screws holding the dispense head in place.



**FIG. 6: Prime Dispense Head**

4. Rotate or remove the dispense head so the tip is above the fluid input hoses.
5. Use a 4 mm hex key to tighten screws holding dispense head in place if applicable.
6. Route the fluid hoses connected to the dispense head so they are always below the dispense head. This ensures any air in the hoses will travel to the dispense head.
7. Navigate to the **Shot Mode Screen** or **Operator Mode Screen**.
8. Ensure there is a sufficient amount of material in the tanks.

9. Select a large size shot.
10. Hold a waste container at the end of the dispense head and press the Dispense Request button () or the footswitch.
11. Repeat the previous step until no air comes out of the dispense valve.
12. If phasing adjustments and ratio checking are not required, use the following procedure to attach the static mixer.
  - a. Attach the static mixer with the dispense head pointed up.
  - b. Hold waste container at end of dispense head and press the Dispense Request button () or the footswitch.
  - c. Repeat the previous steps until static mixer has been purged of air.
13. Use a 4 mm hex key to loosen screws holding dispense head in place.
14. Rotate dispense head back to normal dispensing position.
15. Use a 4 mm hex key to tighten the screws holding the dispense head in place.
16. Adjust snuff back to proper setting for operation. See **Adjust Dispense Valve Snuff Back** on page 31.

## Phasing Adjustment

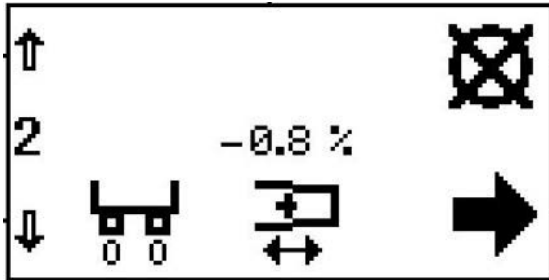

FIG. 7: Phasing Calibration Screen.

When the machine executes a shot, materials from Tank A and Tank B enter the static mixer where they are mixed and then dispensed. In order for the materials to mix at the desired ratio, both materials must enter the static mixer at the same time. The timing of the materials entering the static mixer is dependent on the adjustment of the phase adjustment screw for each piston.

### Prepare the Machine

1. Place a waste container under the dispense valve to catch dispensed material.
2. Remove the static mixer from the dispense valve.
3. Install the ratio check nozzle onto the dispense valve.

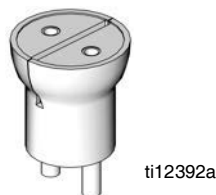



FIG. 8: Ratio Check Nozzle

4. If necessary, place a stand under the ratio check nozzle to support the waste container close to the nozzle.
5. Navigate to the **Phasing Shot Calibration Screen**.

### Adjust Dispense Quantity

6. Press the Phasing shot button (  ) to enter phasing mode.
7. Press the Dispense Request button (  ) or the footswitch to dispense a very small amount of material.
8. Adjust the displayed percentage if more than a couple drops of either material was dispensed or if no material was dispensed from both sides.
  - If too much material was dispensed, decrease the phasing percentage. If necessary, use the arrow keys to switch the percentage from positive to negative.
  - If no material was dispensed, increase the displayed percentage. If necessary, use the arrow keys to switch the percentage from negative to positive.

### Adjust Phasing

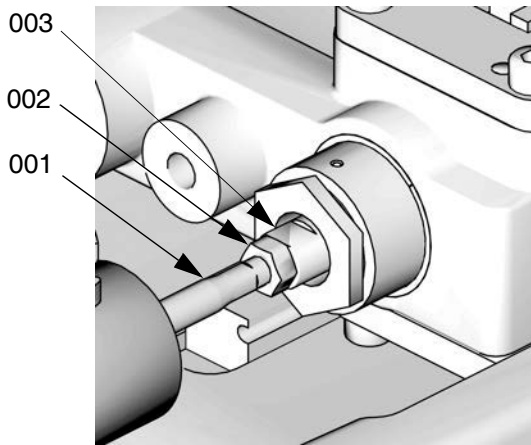

**Key:**



- 001 Piston Shaft
- 002 Locking Nut
- 003 Phase Adjustment Screw

ti12389a

- b. Hold the phase adjustment screw (003) stationary with a 13 mm wrench.
- c. Use a 7 mm wrench to turn the piston shaft (001) counterclockwise 1/4 turn or less to move the A piston forward.

**NOTE:** It is highly recommended that all of the phasing adjustment be done to one side or the other; not both.

**NOTE:** Ensure the piston shaft and phase adjustment screw do not rotate while tightening the locking nut (002) in the following step.

9. Watch the dispense valve carefully to observe which material is dispensed first. Press the Dispense Request button (  ) or the footswitch to dispense material.
10. If the materials do not exit the dispense valve at the same time, adjust the piston Phase Adjustment Screw (003) as follows.
  - If the A side material exits the dispense nozzle before the B side material (  ):
    - a. Use two 13 mm wrenches to break loose the locking nut (002) from the phase adjustment screw (003) on the B material side.
    - b. Hold the phase adjustment screw (003) stationary with a 13 mm wrench.
    - c. Use a 7 mm wrench to turn the piston shaft (001) counterclockwise 1/4 turn or less to move the B piston forward.
  - If the B side material exits the dispense nozzle before the A side material (  ):
    - a. Use two 13 mm wrenches to break loose the locking nut (002) from the phase adjustment screw (003) on the A material side.

11. Hold piston shaft (001) and phase adjustment screw (003) in place with a 7 mm and 13 mm wrench and tighten locking nut (002) against phase adjustment screw with a 13 mm wrench.
12. Watch the dispense valve carefully to observe which material is dispensed first. Press the Dispense Request button (  ) or the foot switch to dispense material. If one material exits the dispense nozzle before the other, go back to step 10.

### Exit Calibration Mode

13. Navigate to the **Shot Mode Screen** or **Operator Mode Screen**.

## Adjust Dispense Valve Snuff Back



At the end of a shot, a small amount of material is drawn back into the static mixer to prevent extra material from being dispensed. If too much snuff back occurs, air will enter the static mixer and can travel up into the dispense valve. If too little snuff back occurs, the materials may drip out of the static mixer and affect dispense quantity.

It is most efficient to adjust the snuff back while material is dispensing, but it can also be adjusted when there is no air pressure in the system.

1. Navigate to the **Shot Mode Screen** or **Operator Mode Screen**.
2. Select a small size shot.
3. If a static mixer is not in place, install one, then prime the machine. See **Prime the Dispense Head**, page 28.
4. Place a waste container under static mixer.
5. Press the Dispense Request button ()
6. Inspect the tip of the static mixer for dripping material or for air bubbles traveling up the mixer.
7. Perform another shot and, while dispensing, adjust the snuff-back adjustment knob as follows.
  - If an air bubble is moving up the mixer, turn the knob clockwise to decrease snuff back.
  - If material is hanging from the tip of the mixer, turn the knob counterclockwise to increase snuff back.
8. Repeat step 7 until snuff back is adjusted as desired.

## Adjust Open Dispense Valve (ODV) Timing



When a shot is performed, the dispense valve needs to open at a precise time for material to be dispensed properly. If the dispense valve opens too early, material may drain from the static mixer before the shot starts. If the dispense valve opens too late, pressure may build in the machine before the dispense valve opens, causing material to forcefully spray out of the mixer.



The Open Dispense Valve Timing should also be adjusted for material viscosity. Thicker materials should have the dispense valve open earlier and thinner materials should have the dispense valve open later.

A positive value for Open Dispense Valve Timing indicates the dispense valve will open after the piston is engaged in the cylinder. A negative value indicates the dispense valve will open before the piston is engaged in the cylinder.

If a high positive number is entered for ODV timing, such as 6.0 mm, the dispense valve may not open resulting in the fluid stalling against the dispense valve. The fluid in the hose lines will remain under pressure until the piston is manually retracted using the Manual screen, see **Operator Mode Screen**.



**FIG. 9: Open Dispense Valve Position Calibration**



1. Navigate to the **Open Dispense Valve Position Calibration Screen**.
2. Press the Dispense Valve Open Position Adjust button, (  ).
3. Use the up and down arrows to enter a value for the ODV Timing.
4. Press the Enter button (  ) to accept the new value or press the Abort/Cancel button (  ) to keep the previous value.



# Operation

## Startup



1. Locate the power switch at rear of machine and turn the power on. The display module will automatically turn on and begin to load.
2. Open the vented ball valve (not provided).
3. If the machine is in Disabled Mode, press the Power On button (  ) to exit Disabled mode and to select a new operating mode. Press the Enter button (  ) to accept the new operating mode.

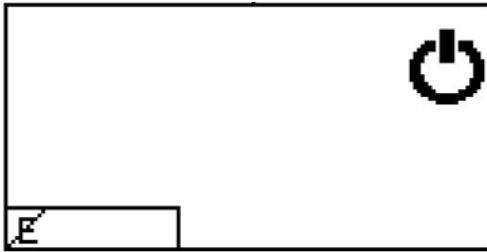

FIG. 10: Disabled Mode



## Pressure Relief Procedure



Follow the Pressure Relief Procedure whenever you see this symbol.



This equipment stays pressurized until pressure is manually relieved. To help prevent serious injury from pressurized fluid, such as skin injection, splashing fluid and moving parts, follow the Pressure Relief Procedure when you stop spraying and before cleaning, checking, or servicing the equipment.

1. Place a waste container below the dispense valve.
2. Navigate to the **Maintenance Mode Run Screen**.
3. Press the Shot Mode Designation button (  ) on the **Maintenance Mode Run Screen** to relieve chemical pressure. Press the Shot Mode Designation button (  ) again to close the dispense valve.
4. Press the Machine Disable Mode button (  ).
5. Close the vented ball valve.

## Shutdown



If the machine is to remain idle for an extended period of time, perform the following steps.

1. If installed, remove static mixer from the end of the dispense valve.
2. Place a container below the dispense valve and activate a small shot to flush mixed material out of the valve.
3. Relieve pressure. See **Pressure Relief Procedure**, page 33.
4. With a clean rag and cotton swabs, clean the end of the dispense valve.
5. Install the nightcap on the dispense valve. Refer to MD2 Valve, Instructions manual for part information.

# Maintenance



## Schedule

Action	Schedule	Procedure
Check Water/Air Separator (Not provided)	Daily before use	<ol style="list-style-type: none"> <li>1. Check water/air separator for water.</li> <li>2. Open valve at base of water/air separator to purge water.</li> </ol>
Check Desiccant Dryer (only installed if chemical is moisture sensitive)	Daily before use	<ol style="list-style-type: none"> <li>1. Check the color of the desiccant</li> <li>2. Replace as required.</li> </ol>
Check Tanks	Daily before use	<ol style="list-style-type: none"> <li>1. Check material levels and refill as necessary.</li> <li>2. Verify the material reservoirs are vented properly.</li> </ol>
Check Dispensing Ratio	Daily before use or as required	See <b>Phasing Adjustment</b> page 29.
Clean Pump Shafts	Daily after shutdown	See <b>Clean the Pump Shafts</b> on this page.
Clean Dispense Head	Daily	See <b>Shutdown</b> on page 34.
Disassemble and Clean Dispense Head	As required	See <b>Disassemble and Clean the Dispense Head</b> on this page.
Upgrade LCM	As required	See <b>Install Upgrade Token</b> on page 36

## Clean the Pump Shafts

1. Close the vented ball valve at the left, rear of the machine.
2. Press the Machine Disable Mode key ().
3. Push the piston block to the fully retracted position.
4. Clean both pump shafts with a compatible solvent and lubricate with mesamoll, silicon oil, or other compatible lubricant.

## Disassemble and Clean the Dispense Head

1. Relieve pressure. See **Pressure Relief Procedure**, page 33.
2. Remove the dispense head from machine.
3. Dismantle the dispense head. See MD2 Dispense Valve manual referenced at the beginning of this manual.
4. Clean all parts.
5. Lubricate all parts with a thin coat of mesamoll, silicon oil, or compatible lubricant.
6. Reassemble the dispense head.
7. Reinstall the dispense head on machine.

## Install Upgrade Token

This procedure applies to the Local Control Module (LCM).

1. Disconnect power to the module.
2. Remove token access panel.

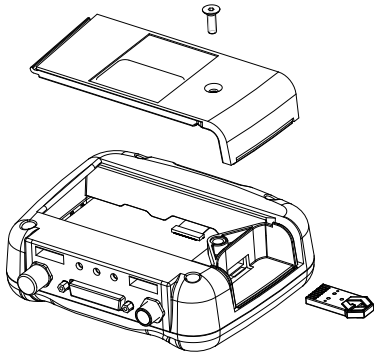

**FIG. 11: Remove Access Panel**

---

3. Press firmly the token into the slot.

**NOTE:** There is no preferred orientation of the token.

4. Restore power to the module. The red LED will flash rapidly to signal that software is loading. When the red LED stops flashing, the software is done loading.
5. Disconnect the power to the module.
6. Remove the token.
7. Replace the token access panel.
8. Restore power to the module.
9. Verify new software versions on the **Setup Screen Password Set/Clear Screen** screen. Refer to PKE 2903 found at [www.graco.com](http://www.graco.com) for the latest software version by utilizing the search box.

# Troubleshooting



Before starting any troubleshooting procedures, perform the following procedure.

1. Relieve pressure. See **Pressure Relief Procedure**, page 33.
2. Disconnect AC power from the machine.

3. Allow the machine to cool if the machine has a heat control option.



Try the recommended solutions in the order given for each problem to avoid unnecessary repairs. Verify all circuit breakers, switches, and controls are properly set and wiring is correct.

Problem	Cause	Solution
Display Module completely dark	No power	Verify cable is plugged in. Verify rear AC Power switch is ON.
	Loose connection	Tighten all cables on Display Module.
	Bad display module	Replace Display Module.
No or incorrect amount of material dispensed from either side.	Tank empty	Fill tank with material.
	Tank clogged	Verify no obstruction in the tank.
	Air in material	Prime the machine until the air is removed.
	Check valve malfunction	Remove; clean or replace check valve.
Piston stalled	Piston worn or broken	Remove and replace piston if worn.
	Input air reduced or removed	Reconnect input air line to machine. Increase air pressure regulator adjustment.
	Mixer blocked	Replace static mixer.
	Open Dispense Valve (ODV) adjustment too late	Readjust the ODV setting to occur sooner.
	Blocked check valve	Remove check valve; clean and replace.
Significant material leaking from pump rear seal	Air cylinder failure	Remove air cylinder and reinstall air cylinder parts as necessary.
	Pump shaft worn and/or shaft seal worn	Remove pump shaft assembly, and reinstall rear pump rebuild kit.
Material dispensed not correct volume	Machine air pressure has changed since calibration.	Readjust air pressure regulator to value used when machine was calibrated, or recalibrate machine.
	Not enough material in one or more tanks	Check tank levels; fill and prime as necessary.
	Mixer has slight obstruction	Replace static mixer. Prime machine.
	Check valve malfunction	Remove check valve; clean or replace as necessary.
	Piston worn or broken	Replace piston.

<b>Problem</b>	<b>Cause</b>	<b>Solution</b>
Machine dispensing off ratio	One tank is empty	Check tank levels. Add material if necessary.
	Tank ball valve closed	Open tank ball valve. Prime machine.
	Machine out of phase	Re-phase machine.
	Check valve malfunction	Remove check valve; clean or replace as necessary.
	Piston worn or broken	Replace piston.
Pumps drawing material back from valve hose	Check valve stuck open	Remove check valve, clean or replace as necessary.

## LCM Error Codes

If an error condition exists, the front Panel LED will blink the number of times corresponding to the error code number, pause, then repeat. After the user acknowledges the generated error screen, the error number will appear on the bottom left-hand side of the main run screen, and the described blink sequence will continue. If more than one error is present, all will be presented, separated by commas. When the condition is cleared, the corresponding error number will be removed from the main run screen. If an error code is present, the machine will not dispense.

Code	Name	Type	Causes	Fixes	Trigger Condition
E3	Improper Machine Calibration 	Alarm	Machine has not been calibrated or has been calibrated incorrectly.	Perform pump position entries in <b>Position Calibration Screen</b> . Retract position must be less than metering tube position, which should be less than the fully extend position.	When requesting a dispense operation.
E4	Bad Linear Position Sensor 	Alarm	<ol style="list-style-type: none"> <li>1. Connection to position sensor disconnected.</li> <li>2. Power to position sensor interrupted.</li> <li>3. Bad position sensor.</li> </ol>	<ol style="list-style-type: none"> <li>1. Verify connections to the sensor.</li> <li>2. Verify proper readings from sensor on setup screen 1.</li> <li>3. Replace sensor</li> </ol>	Invalid readings from the sensor.
E5	Stuck key 	Alarm	<ol style="list-style-type: none"> <li>1. Key is in an active state.</li> <li>2. Tactile switch on LCM is shorted or broke.</li> </ol>	Replace LCM Module.	If key is detected to be active for more than 30 seconds.

# Repair

## HydraCheck Kit Installation, 24W336

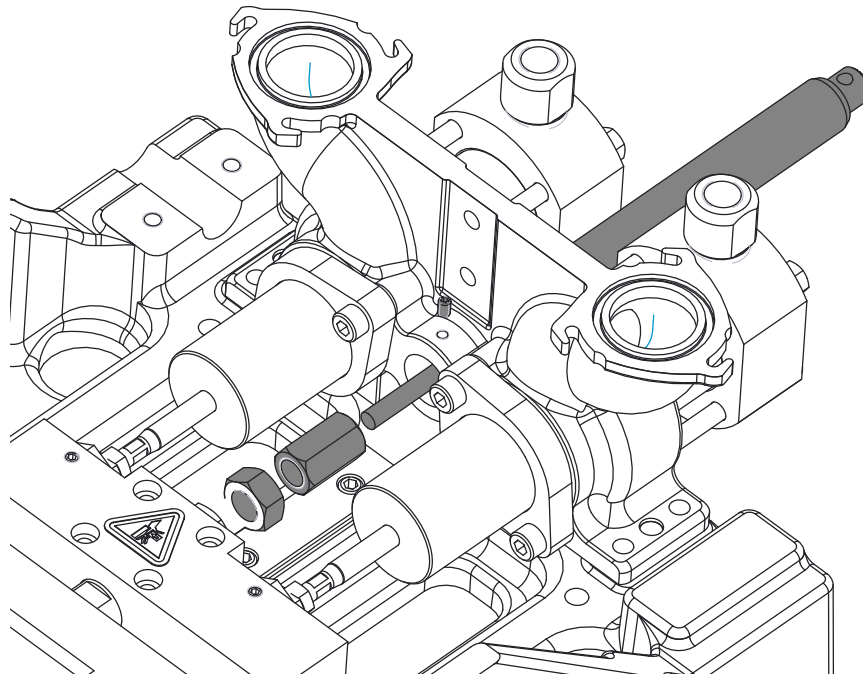
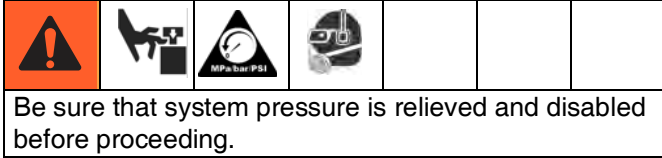

**FIG. 12: HydraCheck Installation - Fixed Ratio Base**

**NOTE:** The HydraCheck kit is intended to be used with low viscosity materials to minimize splashing. It is not intended to be used as a timer or flow control device.

### Prepare Machine for Kit Installation

1. Navigate to the Maintenance screen.
2. Press the Retract Piston button ().
3. Relieve system pressure. See **Pressure Relief Procedure**, page 33.
4. Loosen the machine shield screws.
5. Remove the machine shield.

### Install HydraCheck Shock

6. Install the shock absorber through the opening in the pump sub-assembly with the groove for the snap ring on the back of the pump assembly. The shock absorber can be inserted through the front.
7. Install the shock snap ring (included with shock, not shown) onto the shock absorber in the groove farthest from the pump sub-assembly.
8. Install set screw and torque to 85 in-lb (9.6 N•m).



### **Install Adjustment Screw/Cap**

9. Loosely install hex nut and adjustment cap onto the air cylinder shaft.

### **Adjust the Adjustment Screw/Cap**

10. Push the drive block forward until resistance is felt when it engages the cylinder. Make sure the resistance is not due to shock absorber contact with the adjustment screw or adjustment cap.
11. Adjust the adjustment screw or adjustment cap until it contacts the shock absorber.
12. Hold the adjustment cap in place and tighten the hex nut against the adjustment cap.

### **Prepare Machine for Operation**

13. Open the ball valve to pressurized the system.

### **Adjust Shock Resistance**

14. Execute a shot to see how the shock absorber affects the speed of the drive block.
15. The shock absorber has a numeric scale on one side. Rotate the knob with the scale to a higher value for more resistance. Rotate the knob to a lower value for less resistance.
16. Repeat these steps until the desired resistance is achieved.

# Air Cylinder Rebuild Instructions

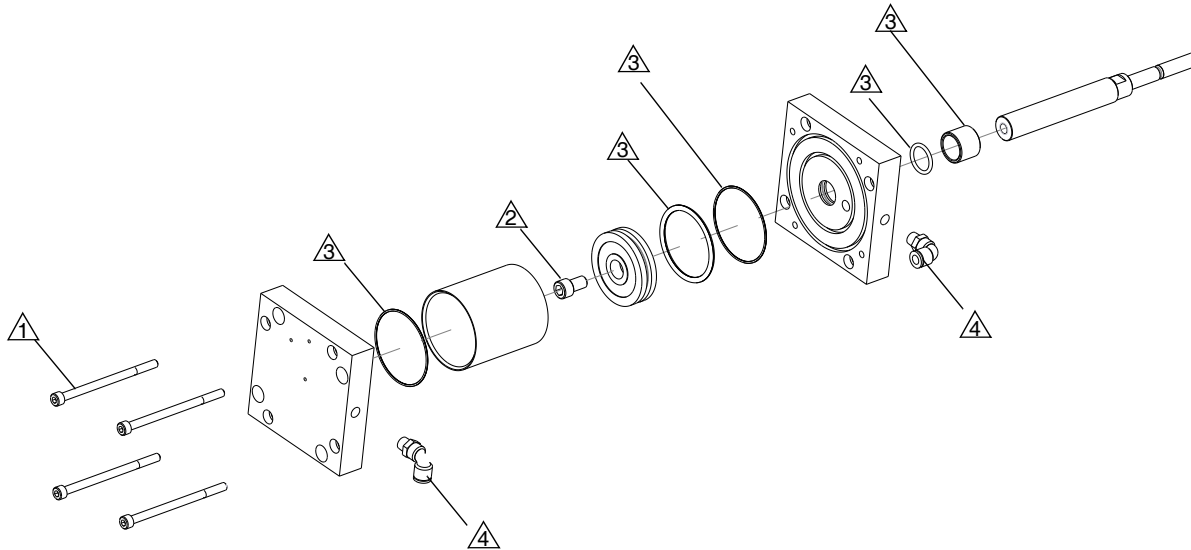
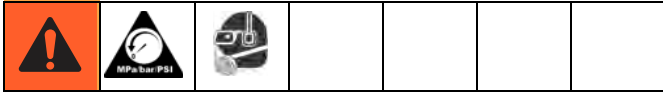

1 Finger tighten all (4) bolts prior to wrench tightening. For wrench tightening, turn each bolt 1/4 turn in a cross pattern until all (4) bolts are torqued to 350 in-lb (40 N•m).

2 Torque to 1200 in-lb (136 N•m).

3 Coat all sliding surfaces with lubricant, part 115982.

4 Apply sealant tape to npt fittings.

## Prepare Machine for Kit Installation

1. Relieve pressure. See **Pressure Relief Procedure**, page 33.
2. Shut down the machine. See **Shutdown**, page 34.
3. Disconnect the pressurized air input hose.
4. Loosen machine shield screws.
5. Remove the machine shield.

## Disassemble the Air Cylinder

6. Remove the incoming power bracket from the machine by removing the four attachment screws.

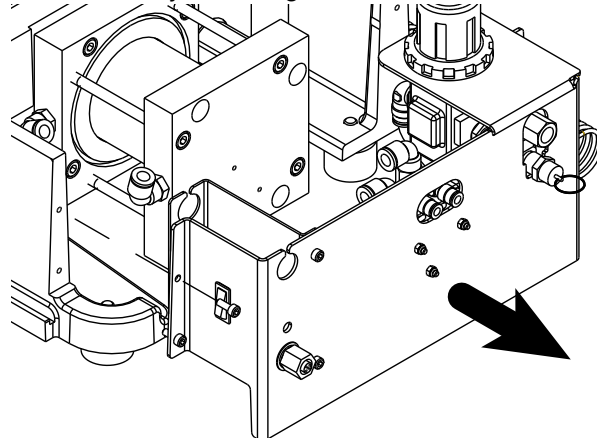

7. Use an open-end wrench to remove all hex nuts connecting the piston rod to the drive block.
8. Remove the four screws that attach the cylinder rod end block to the frame. Access the screws through the four holes in the blind end block using a long allen wrench.
9. Partially remove the air cylinder by pulling on the cylinder from the back of the machine until the air lines at the elbow fittings can be seen.
10. With the cylinder partially removed, disconnect the airlines at the air cylinder elbow fittings.
11. Finish removing the air cylinder.
12. On a bench, disassemble the air cylinder by removing the four long screws that connect the two cylinder blocks.

### Clean and Inspect the Parts

13. Inspect the cylinder tube and piston for scratches. Replace if necessary.
14. Using a clean, dry cloth, remove any grease from the inside of the tube, the outside of the piston, and the cylinder rod.
15. Remove the two cylinder block o-rings from the blocks and replace.
16. Remove the piston o-ring and replace.
17. Remove the cylinder rod from the rod end block.
18. Remove the rod o-ring from the rod end block and replace.
19. Liberally apply high temperature lubricant grease (part 115982) to the inside of the tube, the outside of the piston, all the o-rings, and the cylinder rod.

### Re-Assemble the Air Cylinder

#### NOTICE

In the following step, the long screws must be tightened in a crisscross pattern. Failure to do so may result in air cylinder damage.

20. Reinstall the four long screws that attach the two drive blocks by finger-tightening them. Then torque the bolts to 350 in-lb (39.5 N•m) in a crisscross pattern.

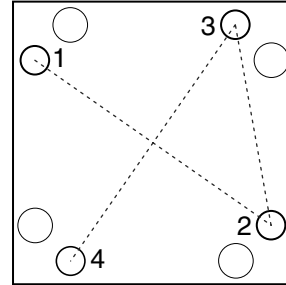

21. Insert the cylinder rod through the hole in the rod end cylinder block and base frame.
22. Reinstall the four screws that attach the cylinder rod end block to the frame.
23. Reinstall the hex nuts to the cylinder rod and torque to 100 ft-lb (135 N•m).
24. Install the three screws that attach the solenoid valves to the blind end block. Torque to 41 in-lb (4.6 N•m).
25. Reinstall the control bracket.
26. Reconnect the air line.

### Prepare Machine for Operation

27. Reattach the incoming power bracket by reinstalling the four attachment screws.
28. Reconnect air input hose.
29. Operate the machine and ensure there are no air leaks found.
30. Install the machine shield.
31. Install machine shield screws.
32. Calibrate the machine.

# Rear Pump Rebuild Instructions

--	--	--	--	--	--	--

The pump shaft is installed coated with Krytox grease. Wear protective gloves and cover exposed skin to avoid possible skin irritation on contact. Read Krytox MSDS to know the specific hazards, and follow manufacturer's warnings.

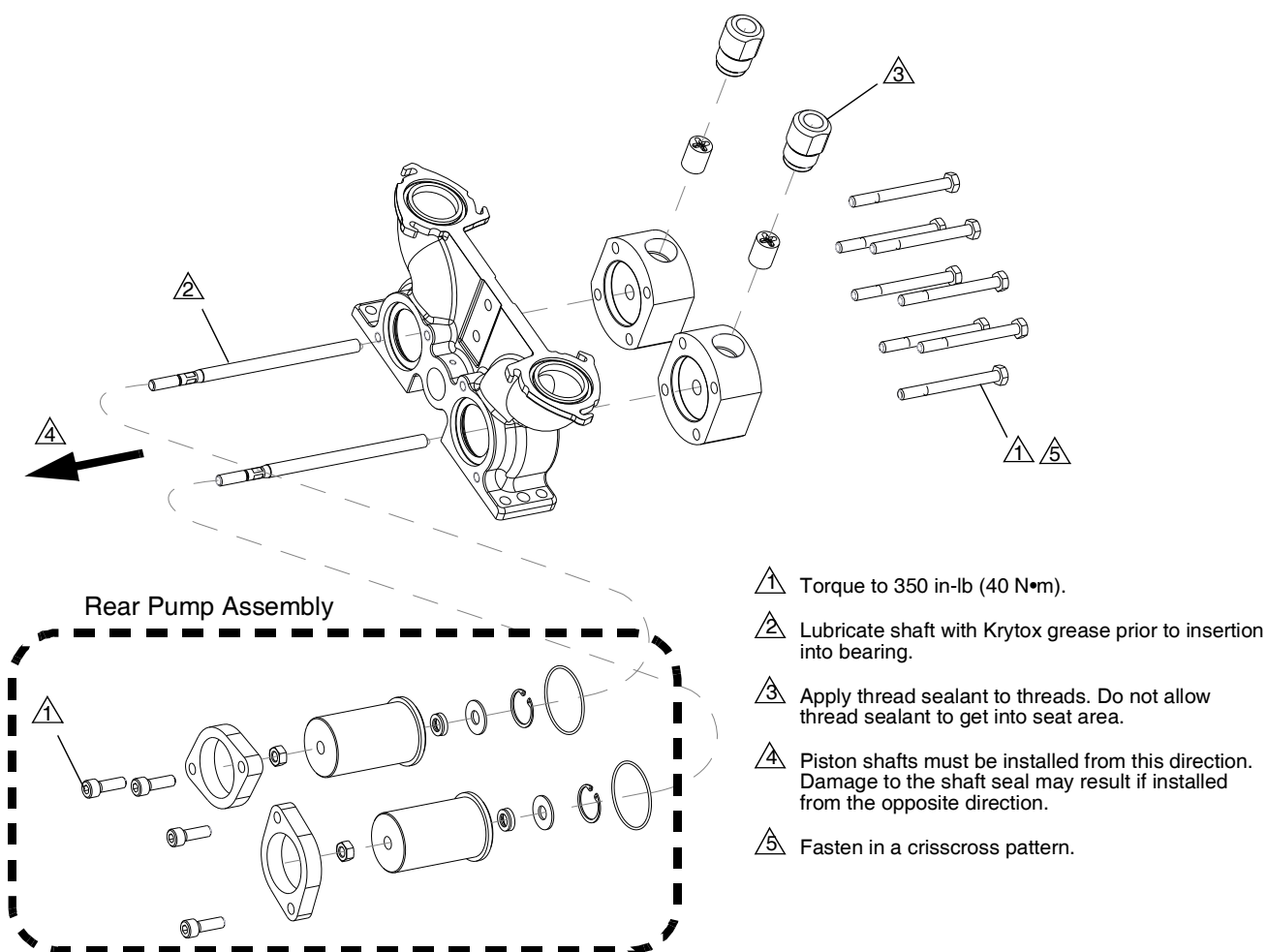

- 1 ⚠ Torque to 350 in-lb (40 N•m).
- 2 ⚠ Lubricate shaft with Krytox grease prior to insertion into bearing.
- 3 ⚠ Apply thread sealant to threads. Do not allow thread sealant to get into seat area.
- 4 ⚠ Piston shafts must be installed from this direction. Damage to the shaft seal may result if installed from the opposite direction.
- 5 ⚠ Fasten in a crisscross pattern.

FIG. 13

### Prepare Machine for Kit Installation

1. Drain the pump. Empty the tanks. Perform shots repeatedly until no material comes out of the dispense valve.
2. Relieve pressure. See **Pressure Relief Procedure**, page 33.
3. Shut down the machine. See **Shutdown**, page 34.
4. Disconnect the pressurized air input hose.
5. Remove machine shield screws.
6. Remove the machine shield.
7. Disassemble the Rear Pump Assembly.

8. Disconnect the pump shaft from the drive block.
    - a. Loosen the shaft locking nut.
    - b. Hold the drive block alignment rod stationary with a wrench.
    - c. Turn the pump shaft with a wrench.
    - d. Manually push the pump shaft forward to separate the shaft from the drive block.
  9. Remove the shaft lock nut.
  10. Remove the two screws that hold the pump collar in place.
  11. Remove the pump collar from the pump housing.
  12. Slide the pump bearing housing away from the pump housing to remove.
  13. Remove rear pump components from the pump bearing housing.
17. Apply one layer of thin masking tape over the male threads of the pump shaft that mates with the drive block. This will prevent the threads from damaging the seal.
  18. Slide the pump shaft through the hole in the bearing housing.
  19. Align the bearing housing in position next to the pump housing.
  20. Install the pump collar over the bearing housing.
  21. Attach the pump housing using the two screws and torque to 350 in-lb (39.5 N•m).
  22. Remove the masking tape from pump shaft.
  23. Install the pump shaft lock nut onto the pump shaft.
  24. Connect the pump shaft to the drive block alignment rod. Screw the shaft completely into the drive block.
  25. Tighten the lock nut.

### Clean and Inspect the Parts

14. Using a clean dry cloth, remove any existing grease from the bearing housing.
15. Apply new high temperature grease lubricant (part 115982) to the inside of the pump bearing housing, and the new rebuild components.

### Assemble the Rear Pump Assembly

16. Install the new rebuild kit components into the bearing housing.

#### NOTICE

Be careful when installing the seal. Ensure there is masking tape on the threads of the piston rod and that the open side of the seal faces the piston rod when it slides onto the rod.

### Prepare for Operation

26. Fill tanks.
27. Perform several shots to fill the pump with new material.
28. Calibrate and phase the machine. Perform **Setup**, page 26.

## Piston/Cylinder Replacement Kit Installation



**NOTE:** See **Piston Package** on page 20 and **Nylon and UHMW Piston Replacement Kits** on page 65 for kit numbers.

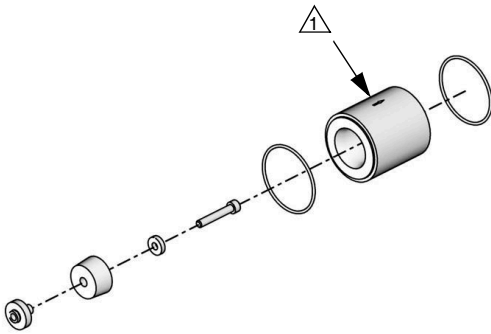

 The arrow imprinted on the cylinder points toward the pump outlet.

### Prepare Machine for Kit Installation

1. Drain the pump. Empty the tanks. Perform shots repeatedly until no material comes out of the dispense valve.
2. Relieve pressure. See **Pressure Relief Procedure**, page 33.
3. Shut down the machine. See **Shutdown**, page 34.

### Disassemble Cylinder

4. Remove the four end cap screws.
5. Remove the pump end caps. Allow the cap to hang by the hose.
6. Remove the cylinder and o-rings from the pump housing.
7. Push the drive block forward until pistons are fully extended.
8. Use a wrench to prevent the pump shaft from rotating and remove the piston screw.

9. Remove the piston and any front or rear washers from the pump shaft.

10. Clean and inspect the washers.

### Install Cylinder

11. Install the new piston and any front or rear washers.
12. Install the piston screw.

**NOTE:** Tighten the piston screw until the screw stops rotating, then turn the screw an additional 1/8 turn.

13. Fully retract the piston.
14. Lubricate the new o-rings with high temperature grease (part 115982).
15. Insert the lubricated o-rings into the grooves of the pump housing and end caps.
16. Install the cylinder between the pump housing and end cap. See note in illustration.
17. Secure cylinder in place with the four end cap screws.

### Prepare Machine for Operation

18. Fill tanks.
19. Perform several shots to fill the pump housing with new material.
20. Calibrate and phase the machine. See the operation manual referenced at the beginning of this manual for procedure.

## Check Valve Rebuild Kit Installation



**NOTE:** See **Pump Sub-Assembly, 24S053**, page 50 for pump sub-assembly part references.

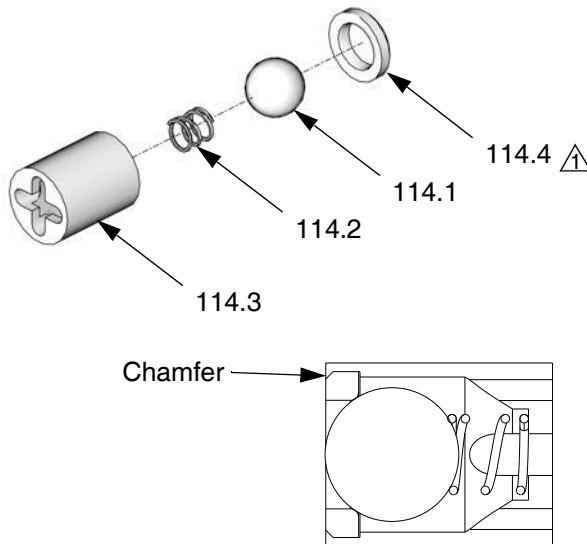

 The side of the seat with an outside diameter chamfer must point away from the ball.

**FIG. 14: Check Valve Rebuild Kit**

### Prepare Machine for Kit Installation

- Relieve pressure. See **Pressure Relief Procedure**, page 33.
- To prevent machine movement, press the Machine Disable Mode key ().
- Place a waste container below the dispense valve to catch any dispensed material.
- Push the drive block forward until pistons are fully extended.
- Move the waste container to below the check valve.
- Disconnect the male hose fitting from the check valve housing by loosening the hose from the housing. See **Pump Sub-Assembly, 24S053**, page 50.
- Remove the check valve housing from the pump endcap by loosening the housing with a wrench.
- Remove the existing check valve from the housing by inserting a screwdriver or dowel rod into the female threaded end of the check valve housing.
- Place the new check valve ball guide (114.3) on a bench with the open end up. Install the check valve spring (114.2) into the guide.
- Install the check valve ball (114.1) on top of the spring (114.2).
- Place the seat (114.4) on top of the check valve ball (114.1) with the outside chamfered side of the seat facing away from the check valve ball.
- Hold both ends of the assembled check valve assembly and install the check valve into the unthreaded end of the check valve housing with the ball end facing out.
- Apply pressure to the valve to snugly fit the assembled check valve into the check valve housing. Fit the check valve seat (114.4) into the valve guide.

**NOTE:** Verify when the assembled check valve and housing are turned up-side down that the contents of the check valve stay in place.

- Use a wrench to insert the new valve and valve housing into the pump end cap.
- Install the material male hose fitting into the check valve housing using a wrench.
- Before operating the machine, activate a few shots to purge any air present in the material hose lines.
- Calibrate the machine if necessary. Perform **Setup**, page 26.

# Parts

## Fixed Ratio Base

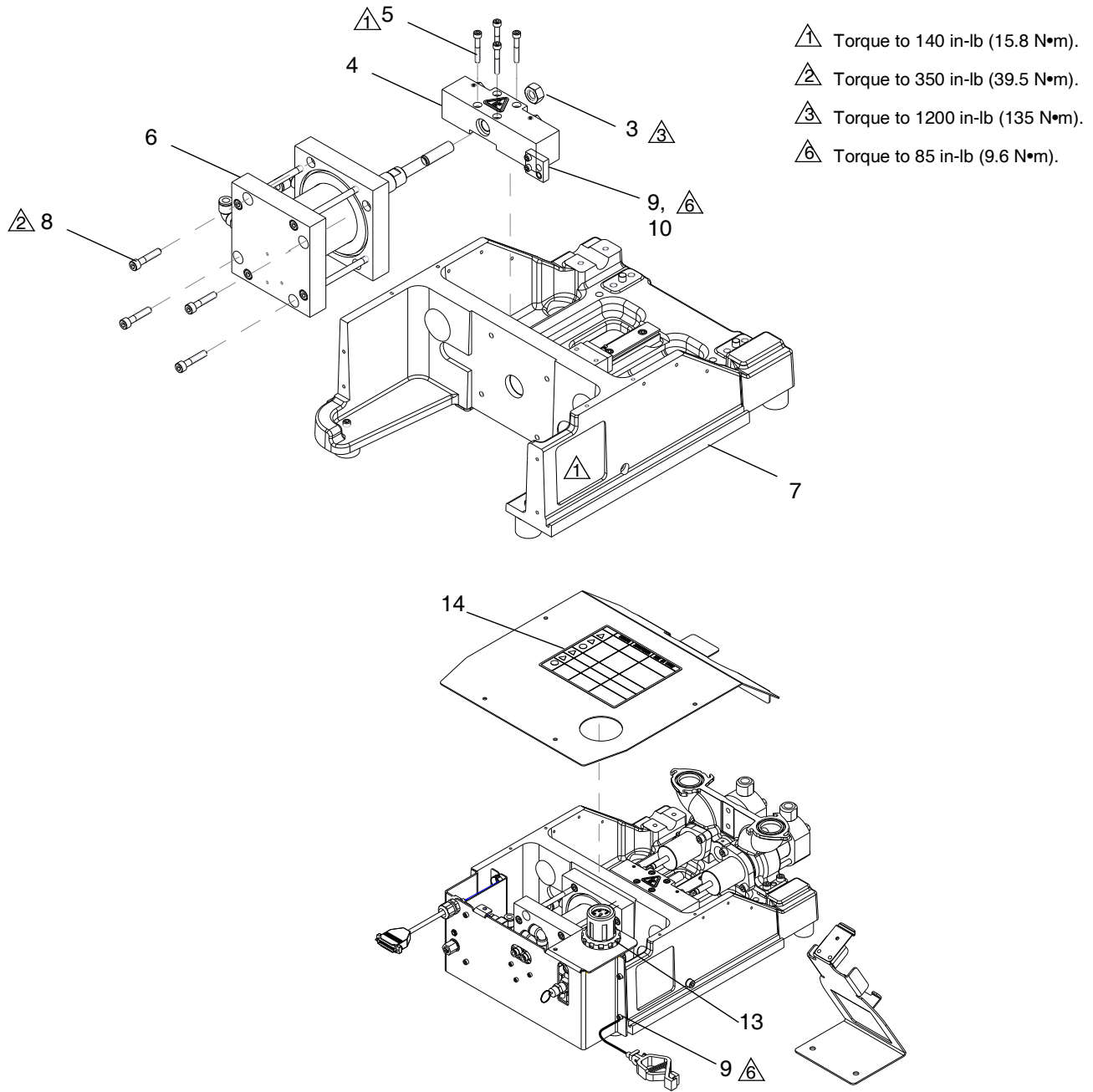

FIG. 15



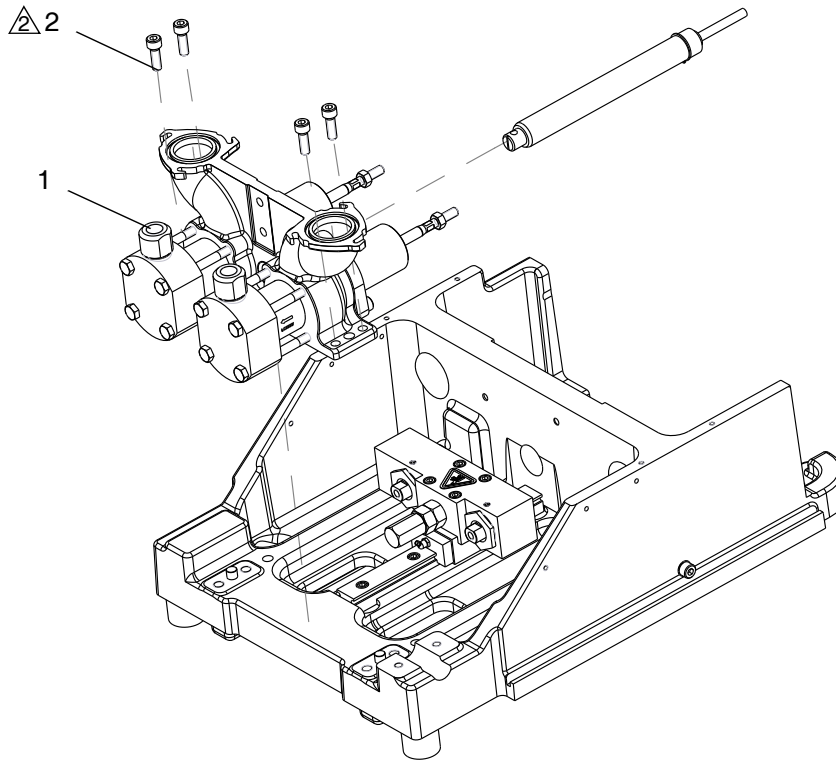

FIG. 16

Ref	Part	Description	Quantity	
			24V935, PUMP, assembly, 3.0	24V936, PUMP, assembly, 4.5
1	24S053	PUMP, sub-assembly	1	1
2	120913	SCREW	4	4
3	120919	NUT, hex	1	1
4	LC0107	BLOCK, assembly, drive	1	1
5	121166	SCREW	4	4
6	24V933	MOTOR, air, 3.0	1	
	24V934	MOTOR, air, 4.5		1
7	LC0290	FRAME, sub, assembly	1	1
8	121167	SCREW	4	4
9	120885	SCREW	6	6
10	---	BRACKET, linear sensor	1	1
13	24V941	BRACKET, power, assembly	1	1
14 ▲	15M511	LABEL, warning	1	1

▲ Replacement Danger and Warning labels, tags and cards are available at no cost.

# Pump Sub-Assembly, 24S053

<p>The pump shaft is installed with Krytox grease. Contact with Krytox grease can lead to flu-like symptoms. The MSDS for this material is available upon request.</p>						

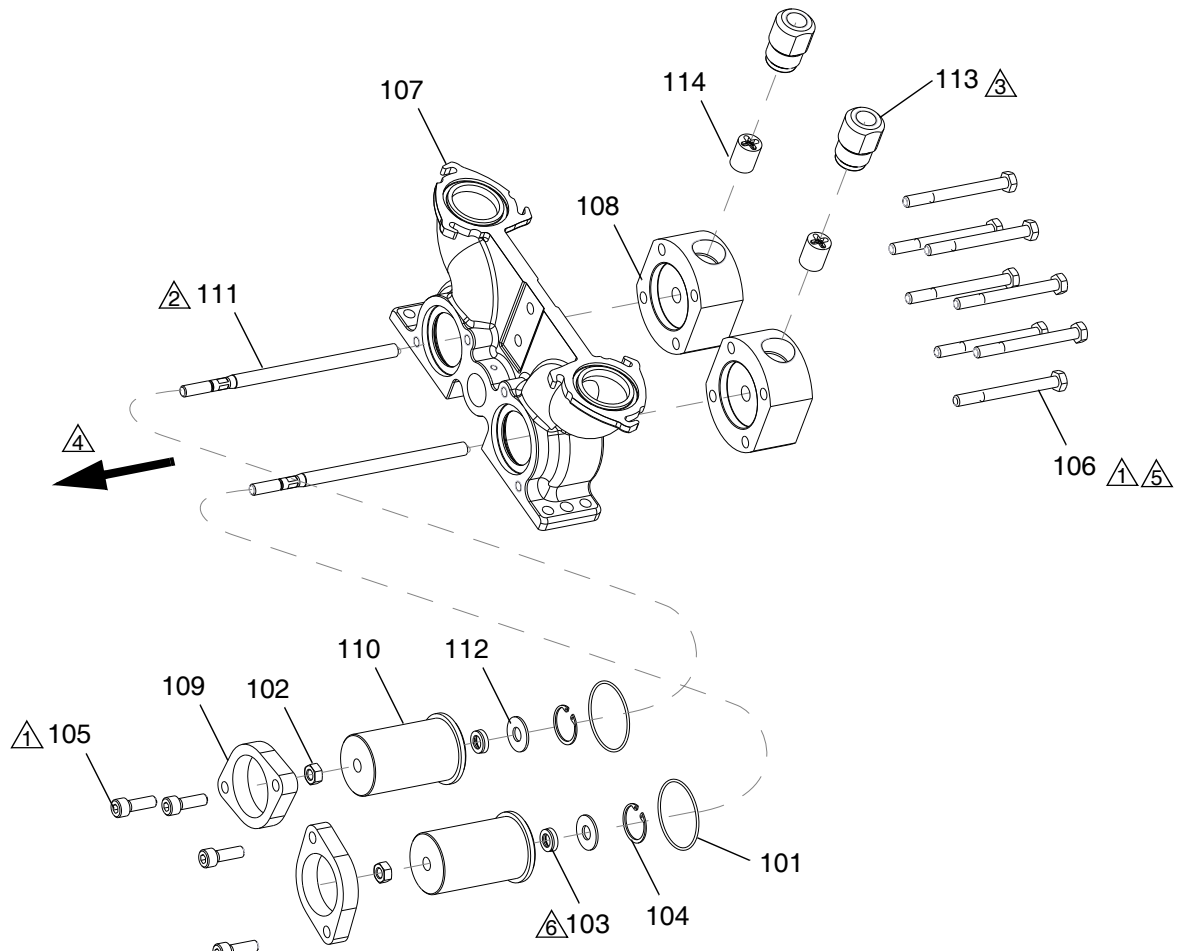

- ⚠1 Torque to 350 in-lb (40 N•m).
- ⚠2 Lubricate shaft with Krytox grease prior to insertion into bearing.
- ⚠3 Apply thread sealant to threads. Do not allow thread sealant to get into seat area.
- ⚠4 Piston shafts must be installed from this direction. Damage to the shaft seal may result if installed from the opposite direction.
- ⚠5 Fasten in a crisscross pattern.
- ⚠6 Note orientation of u-cup. Opening should face pump housing (107).

FIG. 17

Ref	Part	Description	Quantity
101*	106258	PACKING, o-ring	2
102	108712	NUT, hex	2
103*	120887	SEAL, posipak, 3/8x5/8, UHMWPE	2
104*	120890	RING, retaining	2
105	120913	SCREW	4
106	17B389	SCREW, cap, hex head	8
107	15K786	HOUSING, pump	1
108	17B295	CAP, end, pump	2
109	15K803	COLLAR	2
110	15K804	HOUSING, bearing, seal	2
111	15K824	ROD, piston	2
112	15K828	WASHER, housing, seal	2
113	15K895	HOUSING, check valve	2
114	LC0093	KIT, rebuild, valve, check	2

\* Included in kit LC0094.

### Check Valve, Assembly LC0093

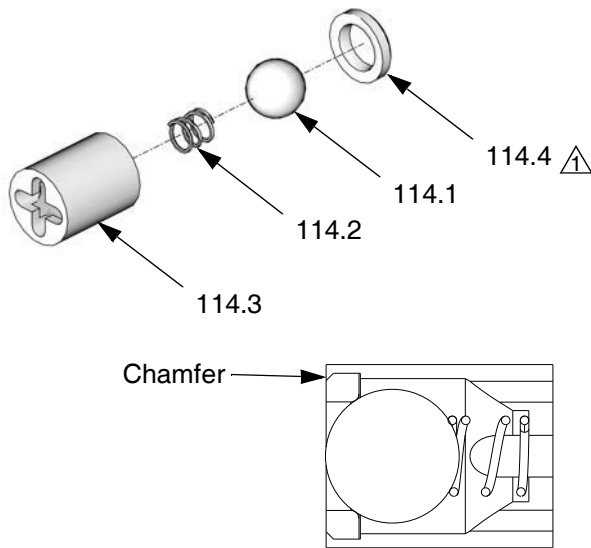

⚠ The side of the seat with an outside diameter chamfer must point away from the ball.

FIG. 18

Ref	Part	Description	Quantity
114.1	105445	BALL, 0.5000	1
114.2	121084	SPRING	1
114.3	15D312	BUSHING, ball guide	1
114.4	196832	SEAT, lapped	1

## Fixed Ratio Drive Block Assembly, LC0107

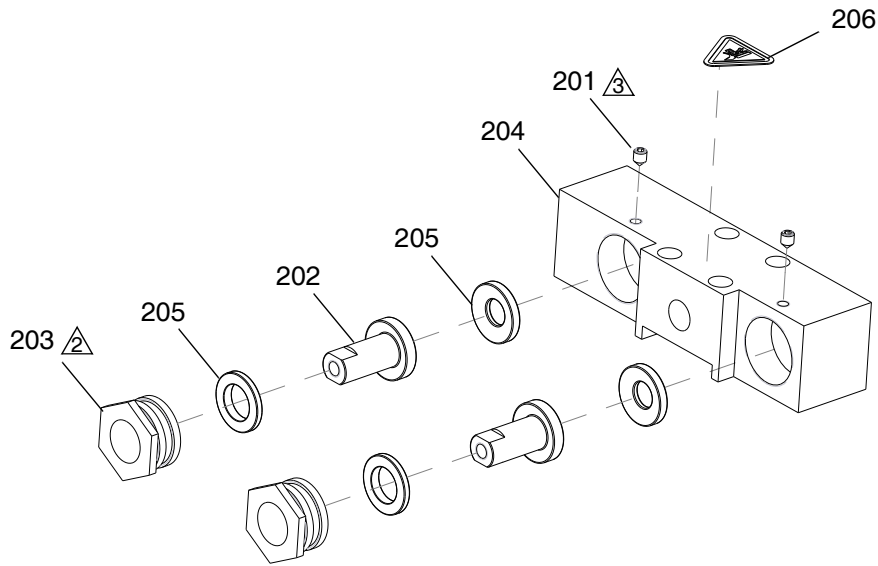

1 Apply grease (part 115982) to all internal parts.

2 Tighten retaining nut until alignment rod (202) cannot be moved. Loosen retaining nut until alignment rod can move side-to-side with no in-and-out movement.

3 Torque to 64 in-lb (7.2 N•m).

FIG. 19

Ref	Part	Description	Quantity
201	120891	SCREW, set, socket, cone point	2
202	15K801	ROD, alignment	2
203	15K802	RETAINER, nut	2
204	15K805	BLOCK, drive	1
205	15K868	WASHER, female, male modified, assembly	2
206 ▲	84_0130-27_11	LABEL, warning, pinch point	1

▲ Replacement Danger and Warning labels, tags, and cards are available at no cost.

## Air Cylinder, 24V933 and 24V934

### NOTICE

The four long screws (303) that attach the two drive blocks (309,310) must be tightened in a crisscross pattern. Failure to do so may result in air cylinder damage. Refer to page 42 for rebuild instructions.

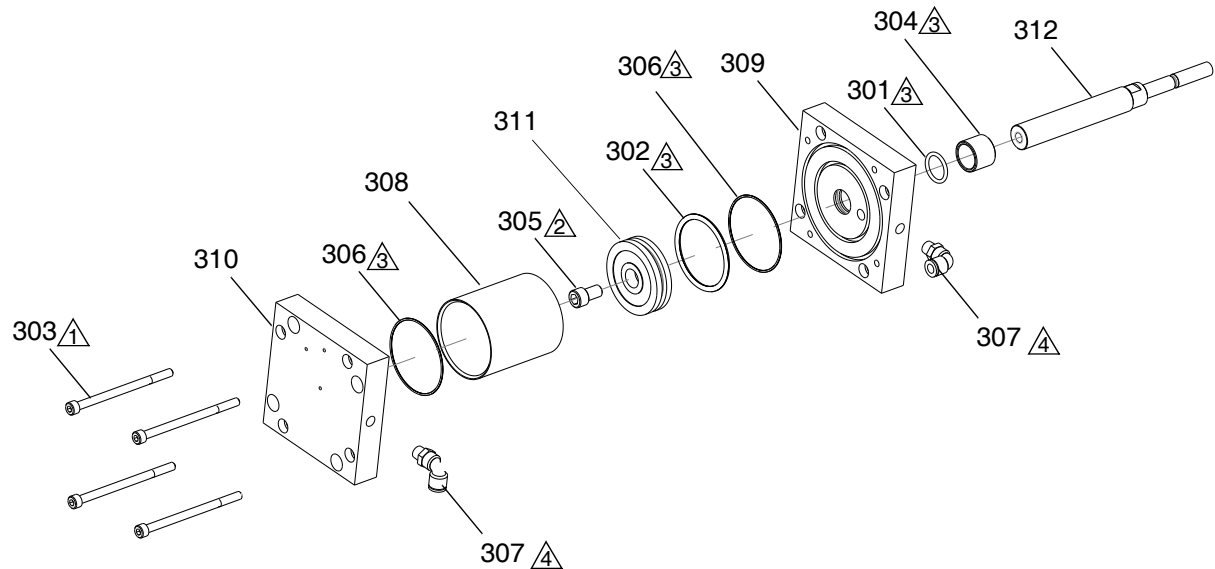

Finger tighten all (4) bolts prior to wrench tightening. For wrench tightening, turn each bolt 1/4 turn in a cross pattern until all (4) bolts are torqued to 350 in-lb (40 N•m).

Torque to 1200 in-lb (136 N•m).

Coat all sliding surfaces with lubricant, part 115982.

Apply sealant tape to npt fittings.

FIG. 20

Ref	Part	Description	Quantity	
			24V933, MOTOR, air, 3.0	24V934, MOTOR, air, 4.5
301	107571†◆	PACKING, o-ring	1	1
302	120875◆	O-RING	1	
	104131†	PACKING, o-ring		1
303	120880	SCREW	4	4
304	120881	BEARING	1	1
305	120884	SCREW	1	1
306	120932◆	O-RING	2	
	104271†	PACKING, o-ring		2
307	121141	FITTING, elbow, swivel	2	2
308	15K790	TUBE, air, cylinder, 3.0	1	
	15K789	TUBE, air, cylinder, 4.5		1
309	15K791	BLOCK, air cylinder, rod end	1	1
310	15K792	BLOCK, air cylinder, blind end	1	1
311	15K793	PISTON	1	
	15K794	PISTON		1
312	15K795	ROD, piston, air cylinder	1	1

† Available in kit LC0092.

◆ Available in kit LC0091.

## Fixed Ratio Frame Sub-Assembly, LC0290

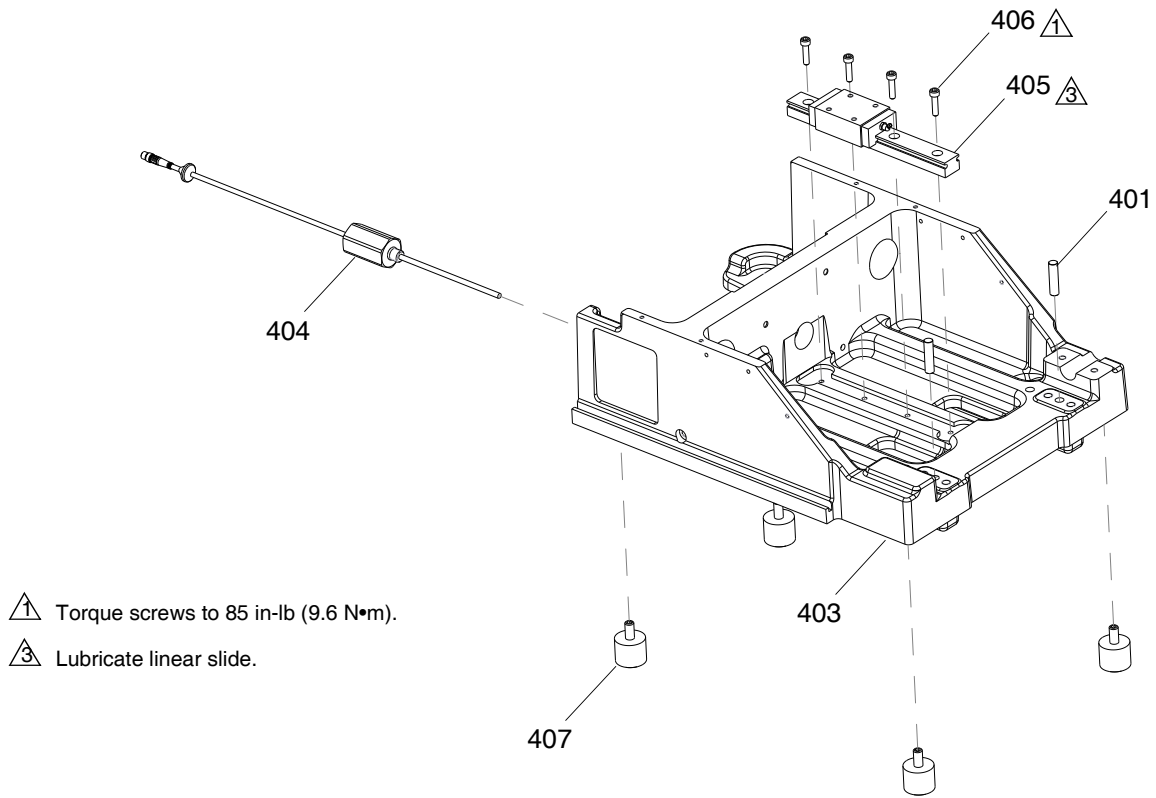

FIG. 21

Ref	Part	Description	Quantity
401	120599	PIN, dowel	2
403	---	FRAME, base, machined	1
404	LC0234	SENSOR, assembly	1
405	120918	BEARING, linear, slide	1
406	120886	SCREW	4
407	17B318	PAD, rubber, anti-vibration	4

## UHMW Piston, Ceramic Metering Tube Assemblies

**NOTE:** The UHMW piston, ceramic metering tube assemblies contain a carbide ball. This ball replaces the standard check valve ball in pump assembly LC0112. If a UHMW piston, ceramic metering tube assembly needs to be installed, replace the original ball in pump assembly LC0112 with the ball included with the pump package. See **Check Valve Rebuild Kit Installation** on page 47 for installation instructions.

Piston Package	Reference Number and Description						
	601	602	603†	604	605	606	607
	Tube, pump	UHMW Piston	Washer	Ring, support, piston	Screw	O-ring	Carbide Ball
LC3160	LCG160	LCA160	15M099	15K887			
LC3180	LCG180	LCA180					
LC3200	LCG200	LCA200					
LC3220	LCG220	LCA220					
LC3240	LCG240	LCA240					
LC3260	LCG260	LCA260					
LC3280	LCG280	LCA280					
LC3300	LCG300	LCA300	15M100	15K888	120933	120874	116166
LC3320	LCG320	LCA320					
LC3360	LCG360	LCA360					
LC3400	LCG400	LCA400					
LC3440	LCG440	LCA440					
LC3480	LCG480	LCA480					
LC3520	LCG520	LCA520					
LC3560	LCG560	LCA560					
LC3600	LCG600	LCA600					
LC3640	LCG640	LCA640					
LC3720	LCG720	LCA720	15M101	15K890			
LC3800	LCG800	LCA800					
LC3880	LCG880	LCA880					
LC3960	LCG960	LCA960					
<b>Quantity</b>	1	1	1	1	1	2	1

† For custom piston packages, washer (603) part number will change by piston size as follows:

For piston sizes 80-100cc: 15M089

For piston sizes 101-159cc: Washer not used.

For piston sizes 160-285cc: 15M099

For piston sizes 286-646cc: 15M100

For piston sizes 647-960cc: 15M101

# Schematics

## Electrical Schematics

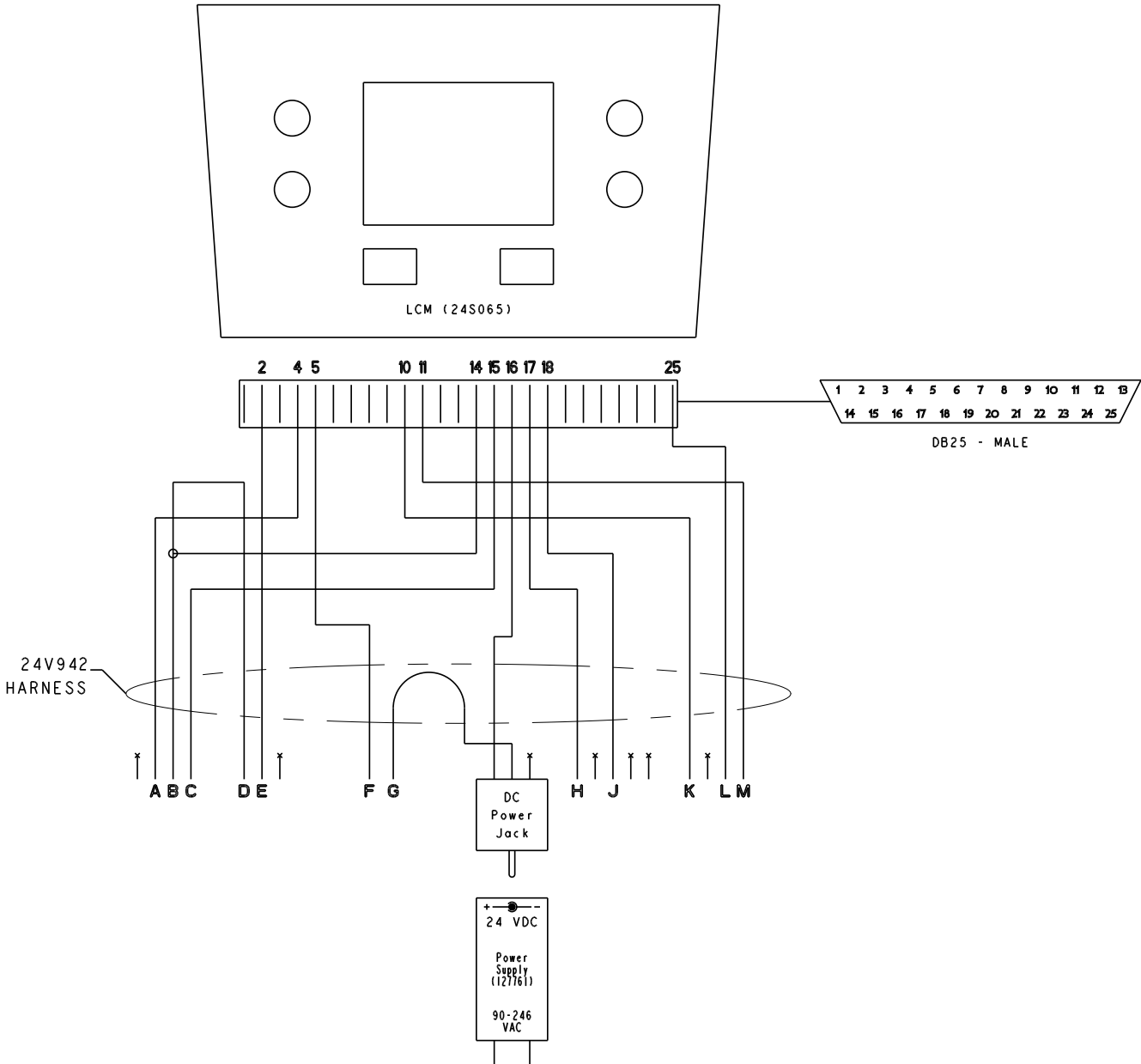

FIG. 22: Electrical Schematic



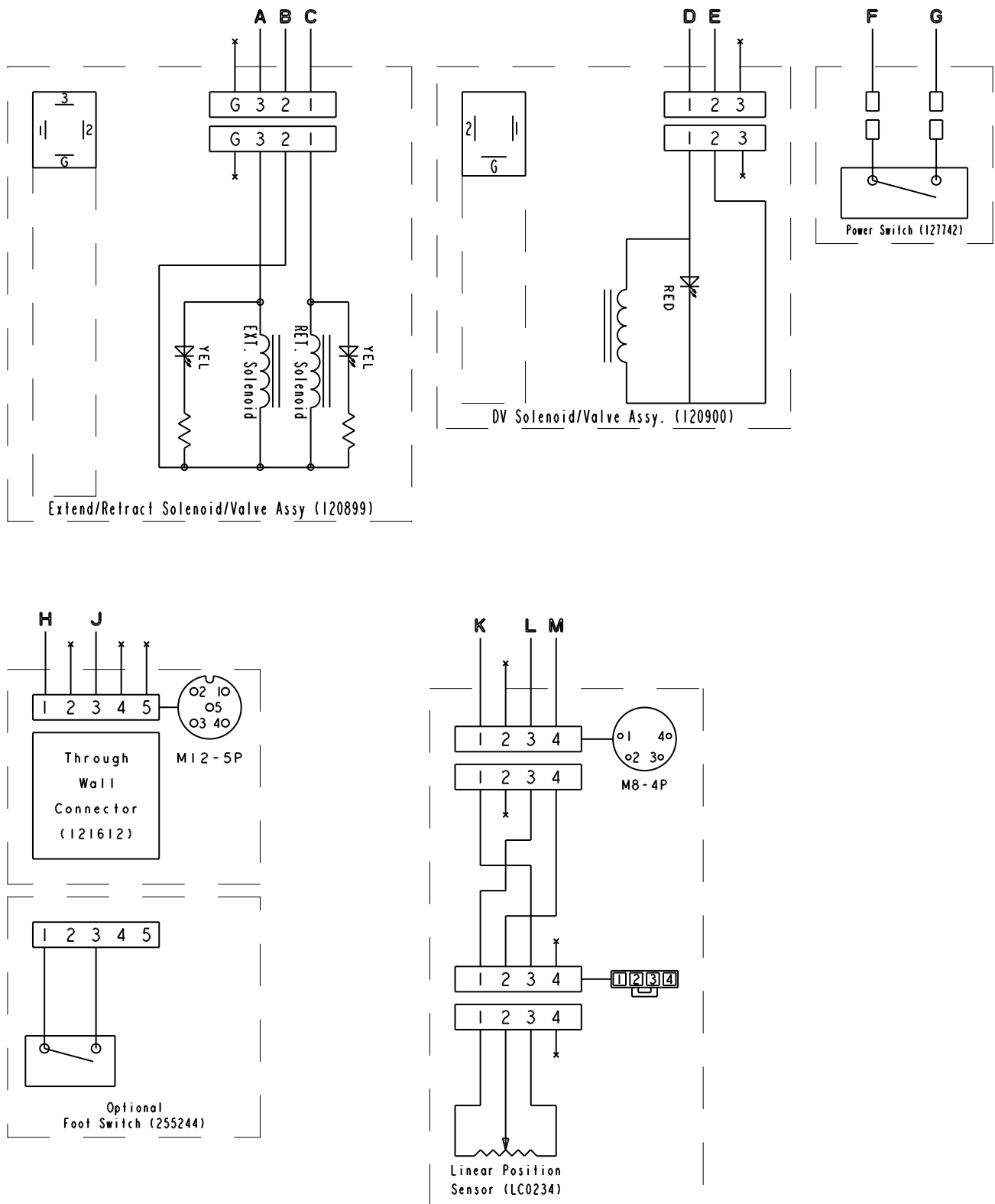
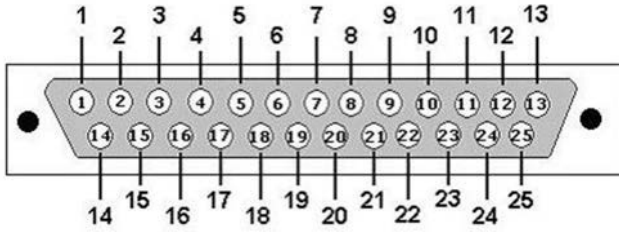

FIG. 23: Electrical Schematic

### DB25 Pin Function



DB25 Pin Number	Pin Function	Description
17	Digital In 1	Footswitch/Shot Request Input
11	Analog In 1	Position Sensor Analog Input
2	Source Digital Out 1	Dispense Valve (DV) Open Command
15	Source Digital Out 2	Pump Retract Command
4	Source Digital Out 3	Pump Extend Command
5	V_CAN (+24V)	LCM and Module Power Feed
14	V_CAN_RTN (-24V)	Return for Extend, Retract, and DV Commands
16	V_CAN_RTN (-24V)	LCM - Module Power Feed
18	V_CAN_RTN (-24V)	Return for Footswitch Connector
10	5 Volts (+)	Position Sensor + Feed (Existing)
25	5 Volts (-)	Position Sensor - Feed (Existing)

### Pneumatic Schematic

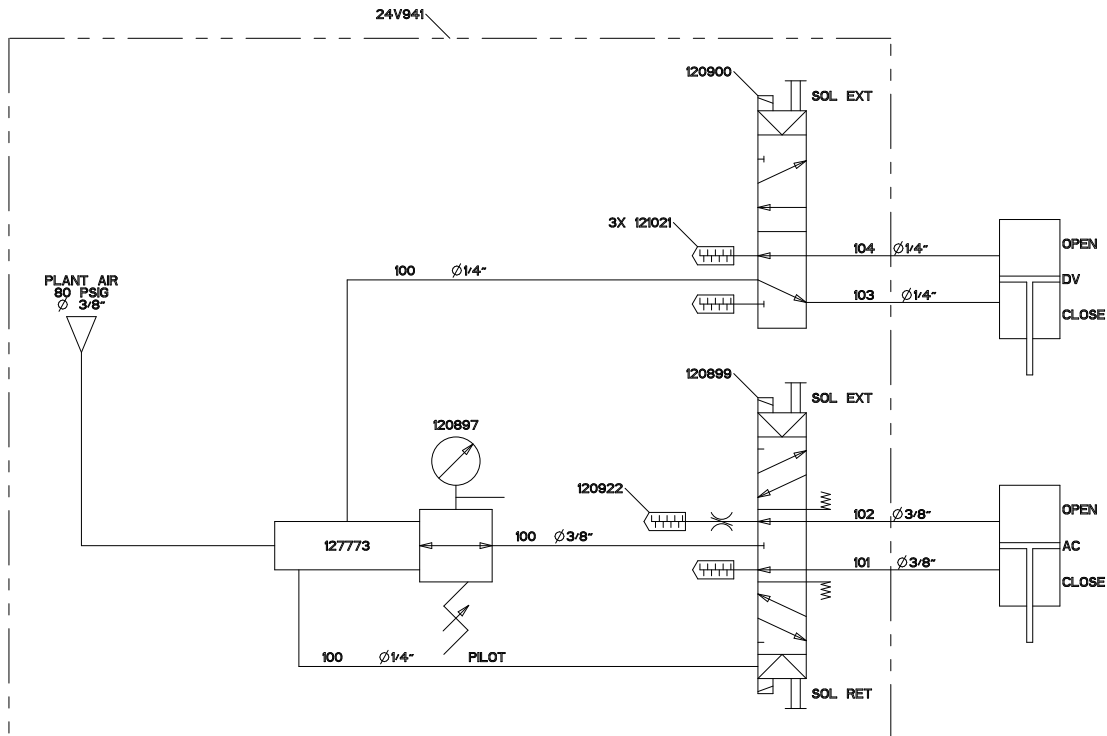





















FIG. 24: Pneumatic Schematic



## Appendix A - LCM Icon Overview

Icon	Label	Description
	<b>Power On</b>	When the corresponding soft key is pressed, the PR70 will exit disable mode and enter the last mode used (Shot or manual) and display the corresponding mode on the home run screen.
	<b>Shot Mode Designation</b>	Used on main home screen to indicate the machine is in shot mode. On the maintenance mode screen, it also indicates the user wants to either close or open the machine dispense valve.
	<b>Operator Mode Designation</b>	Used on main home screen to indicate the machine is in Manual mode.
	<b>Maintenance Mode Designation</b>	Used on main home screen to indicate the machine is in Maintenance mode.
	<b>Mode Select Designation</b>	When the corresponding soft key is pressed, the machine will enter a mode select run screen.
	<b>Setup Screen Designation</b>	When the corresponding soft key is pressed, the machine will enter the start of the setup screens for the machine.
	<b>Next Field Designation</b>	When the corresponding soft key is pressed, the user will navigate into a screen or to the next field within a screen.
	<b>Accept User Entry</b>	When the corresponding soft key is pressed, the user accepts the value(s) or options shown on the screen.
	<b>Abort User Entry</b>	When the corresponding soft key is pressed, the user aborts the value(s) or options shown on the screen. Activating this option will essentially allow the user to go back one step in the programming or screen navigation sequence.
	<b>Stuck Key</b>	Graphic used to indicate that the control has detected that one of the keys is stuck in the ON position.
	<b>Bad Linear Sensor</b>	Graphic used to indicate that the control has detected that readings from the linear position sensor are invalid.
	<b>Improper Machine Calibration</b>	Graphic used to indicate that the control has no or invalid readings for the extend, retract and metering tube positions.
	<b>Retract Position</b>	Graphic used to indicate the full retract position of the pump.
	<b>Extend Position</b>	Graphic used to indicate the full extend position of the pump.
	<b>Metering Tube Entrance Position</b>	Graphic used to indicate the position on the pump where the piston first enters the pump metering tube.

Icon	Label	Description
	<b>Phasing Shot</b>	Graphic used to indicate the user wants to arm the machine to allow phasing shots when the user presses the dispense key, or presses the optional machine footswitch input.
	<b>Phasing Shot Adjust</b>	Graphic used to indicate the user wants to adjust the position into the metering tube where the pump reverses during the phasing shot dispense.
	<b>Dispense Valve Open Position Adjust</b>	Graphic used to indicate the user wants to adjust the position with respect to the metering tube entrance where the valve is opened during the extend stroke of the pump of a dispense operation.
	<b>Allow Shot Amount Adjust</b>	Graphic used to indicate the user wants to allow shot amount adjustment from the main shot mode run screen.
	<b>Do Not Allow Shot Amount Adjust</b>	Graphic used to indicate the user does not want to allow shot amount adjustment from the main shot mode run screen.

# Appendix B - LCM Run Screen Overview

## Splash Screen



This screen is activated during a boot up condition. The splash screen will only be present approximately for five seconds.

## Operator Mode Screen

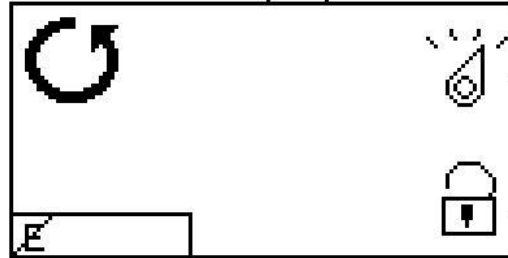

This mode is the dispensing mode where the dispense amount is dictated by the duration the user is requesting the dispense. To dispense in this mode, the user can either press and hold the dispense key, or press and hold an optional footswitch. If the user releases the footswitch or dispense key, the dispense operation will terminate, and the pump will return to the retract position unconditionally.

## Disable Mode Screen

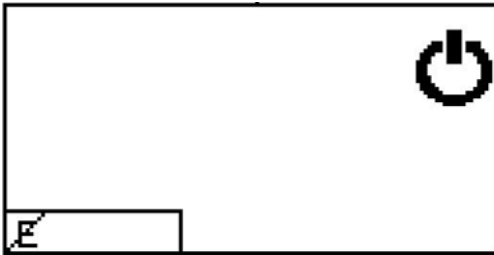

When the system is in this mode, all outputs are disabled. This mode is activated in the bootup situation, or if the user presses the System Shut-Down Key. To exit this mode, the user simply needs to press the Power On icon softkey.

## Mode Selection Programming Screen

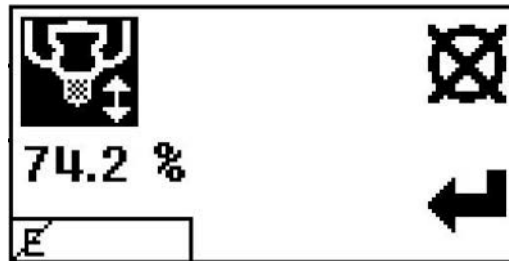

This programming mode is entered by pressing the mode select designation soft key option, from any of the three possible run mode screens. When activated, the user can select between Shot, Manual and Maintenance modes. The highlighted graphics in the top left portion of the display will indicate the current selection.

## Shot Mode Screen

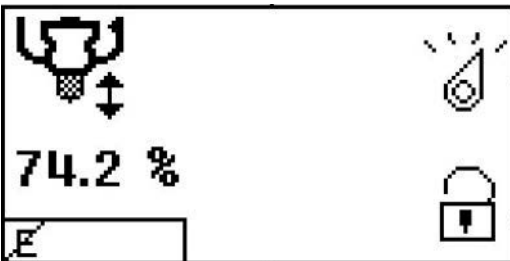

This mode is the dispensing mode where the user can define a shot amount by defining the percentage of stroke for the dispense operation. When dispensing in this mode, the machine will produce the same amount of material for each dispense. To dispense out of this mode, the user needs to momentarily press the dispense key, or press an optional footswitch.

### Maintenance Mode Run Screen

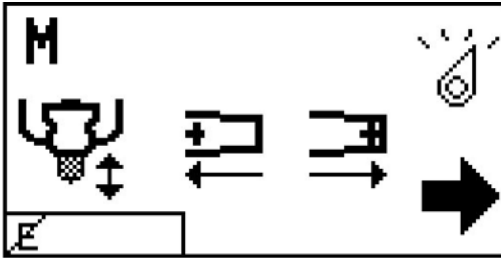

Used for machine testing. The user will be able to extend or retract the pump, or open and close the dispense valve from this screen. Once the user has navigated to function to be implemented, the user simply needs to press the dispense request key to issue the request.

### Shot Amount or Stroke % Adjust Screen

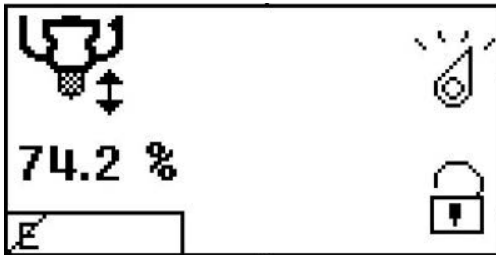

If in shot mode, and the user has enabled this run screen adjustment (via a setup screen option), the user can adjust the shot amount by simply pressing the Up or Down arrow keys, then pressing the accept user entry softkey. The minimum percent required is 15 percent.

### Run Screen while Dispensing

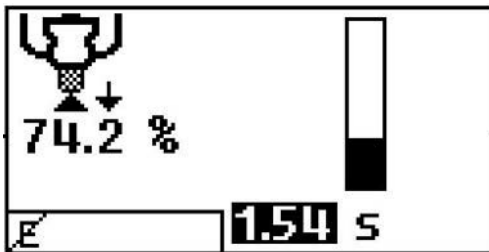

Additional information is provided during a dispense operation, consisting of a progress bar representing the current % complete of the dispense operation (shot mode only), and the amount of time elapsed for a dispense. During a dispense, the run screen programming options are no longer available. Once the dispense is completed, the screen will return to the main home run screen.

### Error Code Acknowledgement Screen

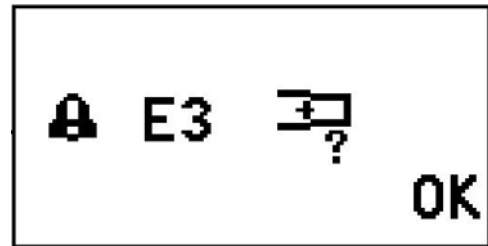

This screen will be generated if an error condition becomes active. The screen will contain the code for the condition, a graphic describing the condition, the standard Graco alarm bell, and a soft key prompting the user to acknowledge the condition. Once the condition has been acknowledged by the user, the screen will return to the main run screen. If the condition is still present after acknowledgement, the code previously presented to the user will be displayed on the bottom left hand corner of the main run screen. Once the condition is corrected, the code displayed will be removed.

# Appendix C - LCM Setup Screen Overview

## Password Entry Screen



If a password is programmed into the LCM, the user will be prompted to enter a password. If no password has been entered (all 0's on the password set/ clear setup screen), this screen will be bypassed.

## Position Calibration Screen

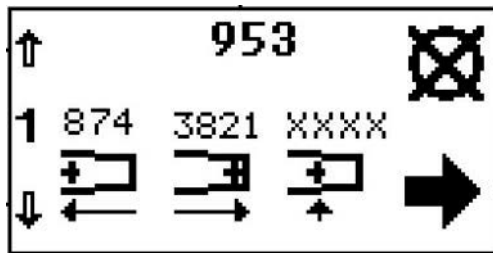

This screens is used to set or observe the proper positions on the linear position sensor for full extend, retract and entrance into the metering tube. All valid entries must be present for the machine to operate. The extend position must be greater than the metering tube position, which must be greater than the retract position. When the position is accepted, the real time position sensor reading in the middle of the screen will be transferred to above the graphic for the corresponding position. The process needs repeated for all three positions.

## Phasing Shot Calibration Screen

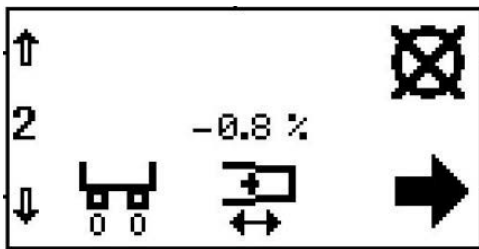

This screen is to instigate a phasing shot, and to define the percentage of stroke for a phasing shot.

## Open Dispense Valve Position Calibration Screen



This screen is to set or view the position with reference to the metering tube entrance where the dispense valve is opened during the forward stroke of the pump.

## Dispense Amount Prohibit and View Cycle Counter Screen



This screen will enable the user to lock out or enable the operator to change stroke percentage for the shot mode run screen. The user will also be able to view the machine cycle counter.

## Setup Screen Password Set/Clear Screen



This screen will allow the user to view, set or clear (by entering four 0's) the password. Setting a new password or clearing the password feature is identical to the method used to enter the setup screen, if a non-zero password is present.



# Kits

## Nylon and UHMW Piston Replacement Kits

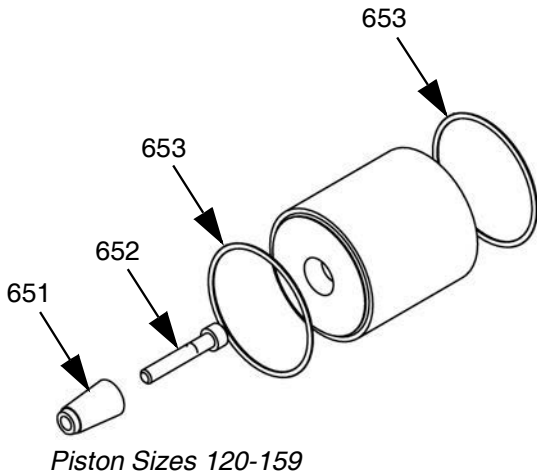
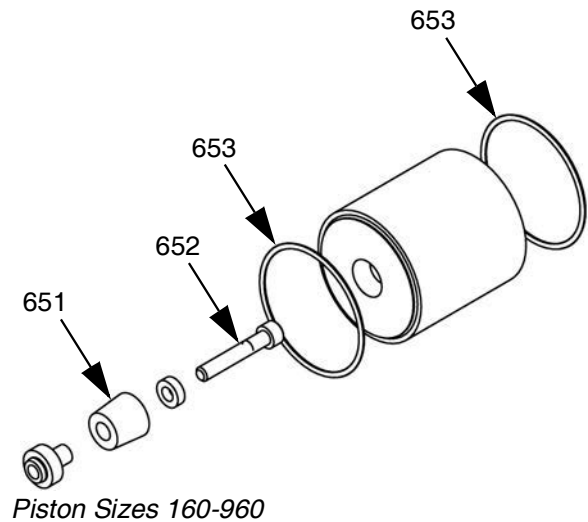
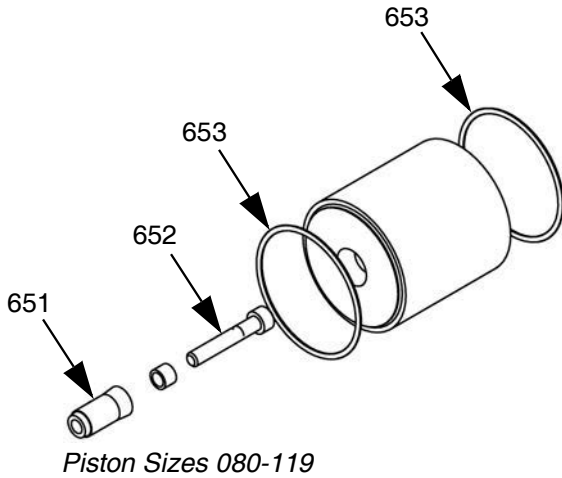

Ref	Part	Description	Quantity
651	---	PISTON	1
652	---	SCREW	1
653	---	O-RING	2

When ordering a piston replacement kit, the following intelligent part numbering system applies for Nylon based pistons.

### LCF - Piston Size (mm2)

When ordering a UHMW replacement kit, the following numbering applies:

### LCE - Piston Size (mm2)

The items indicated above will be supplied with the kit.

## Kits

### Mixer and Shroud Options

Part	Description
LC0063	Mixer, 3/16 in. (6.5 mm) x 32, 10 Mixers with shroud
LC0057	Mixer, 1/4 in. (6.5 mm) x 24, 10 Mixers with shroud
LC0058	Mixer, 3/8 in. (9.8 mm) x 24, 10 Mixers with shroud
LC0059	Mixer, 3/8 in. (9.8 mm) x 36, 10 Mixers with shroud
LC0060	Mixer, 3/8 in. (9.8 mm) Combo, 10 Mixers with shroud
LC0061	Mixer, 3/16 in. (4.8 mm) x 32 Luer Lock, 10 Mixers with shroud
LC0062	Mixer, 1/4 in. (6.5 mm) x 24 Luer Lock, 10 Mixers with shroud
LC0077	Mixer, 3/16 in. (4.8 mm) x 32, 50 Mixers
LC0078	Mixer, 1/4 in. (6.5 mm) x 24, 50 Mixers
LC0079	Mixer, 3/8 in. (9.8 mm) x 24, 50 Mixers
LC0080	Mixer, 3/8 in. (9.8 mm) x 36, 50 Mixers
LC0081	Mixer, 3/8 in. (9.8 mm) combo, 50 Mixers
LC0083	Mixer, 1/4 in. (6.5 mm) x 24 Luer Lock, 50 Mixers
LC0082	Mixer, 3/16 in. (4.8 mm) x 32 Luer Lock, 50 Mixers
LC0084	Mixer, 3/16 in. (4.8 mm) x 32, 250 Mixers
LC0085	Mixer, 1/4 in. (6.5 mm) x 24, 250 Mixers
LC0086	Mixer, 3/8 in. (9.8 mm) x 24, 250 Mixers
LC0087	Mixer, 3/8 in. (9.8 mm) x 36, 250 Mixers
LC0088	Mixer, 3/8 in. (9.8 mm) combo, 250 Mixers
LC0089	Mixer, 3/16 in. (4.8 mm) x 32 Luer Lock, 250 Mixers
LC0090	Mixer, 1/4 in. (6.5 mm) x 24 Luer Lock, 250 Mixers

### Tank Accessories

See the PR70™ and PR70v™ Feed Systems Instructions-Parts Manual for the parts included with each kit. See Related Manuals.

### MD2 Valve Kits

See MD2 Dispense Valve instruction manual referenced at the beginning of this manual for installation instructions or for more information.

Part	Description
255217	MD2, kit rebuild, air cylinder
255218	MD2, kit rebuild, back-end of wet section (no needle or seat)
255219	MD2, Soft Seat rebuild, needle and nose
255220	MD2, convert Soft Seat nose to Hard Seat (Hard Seat rebuild), needle and nose

### Machine Rebuild Kits

See the PR70™ and PR70v™ Repair - Parts manual referenced at the beginning of this manual for parts included in each kit.

Part	Description
LC0091	3.0 in. Air Cylinder rebuild kit
LC0092	4.5 in. Air Cylinder rebuild kit
LC0093	Check Valve rebuild kit, Stainless Steel Ball
LC0318	Check Valve rebuild kit, Carbide Ball
LC0094	Rear Pump Seal rebuild kit
16H378	LCM Screen Protector

### Heat Zone Controller

N/A	None
LC0250	1 Tank or 1 Hose
LC0251	2 Tanks, 1 Tank and 1 Hose, or 2 Hoses
LC0252	2 Tanks and 1 Hose, or 1 Tank and 2 Hoses
LC0253	2 Tanks and 2 Hoses

### PR70™ ISO Lube Recirculation Kit

Part	Description
25U135	PR70™ ISO Lube Recirculation Kit - With 230 VAC Pump
25U137	PR70™ ISO Lube Recirculation Kit - Without Pump
25U199	PR70™ ISO Lube Recirculation Kit - With 120 VAC Pump

# Dimensions

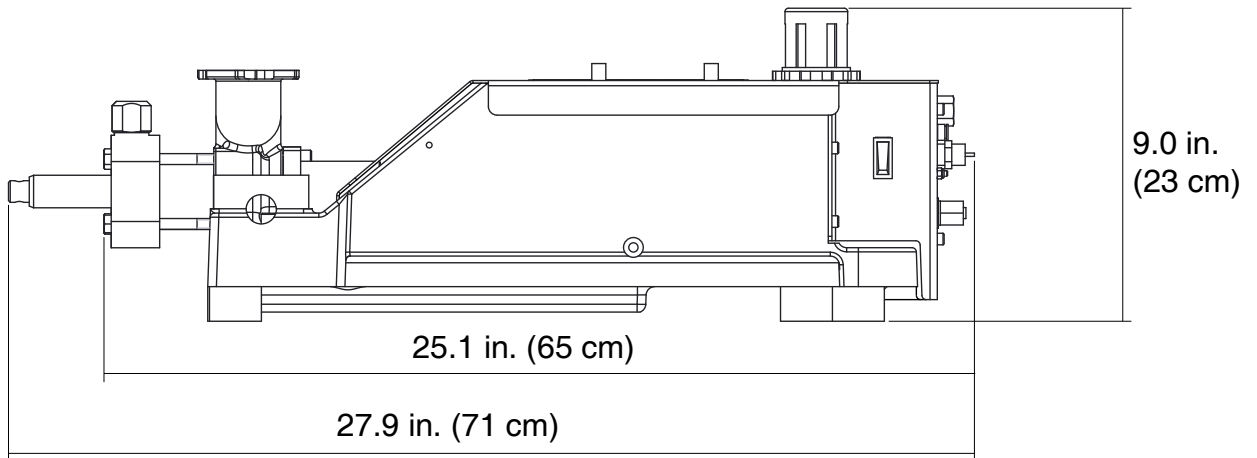
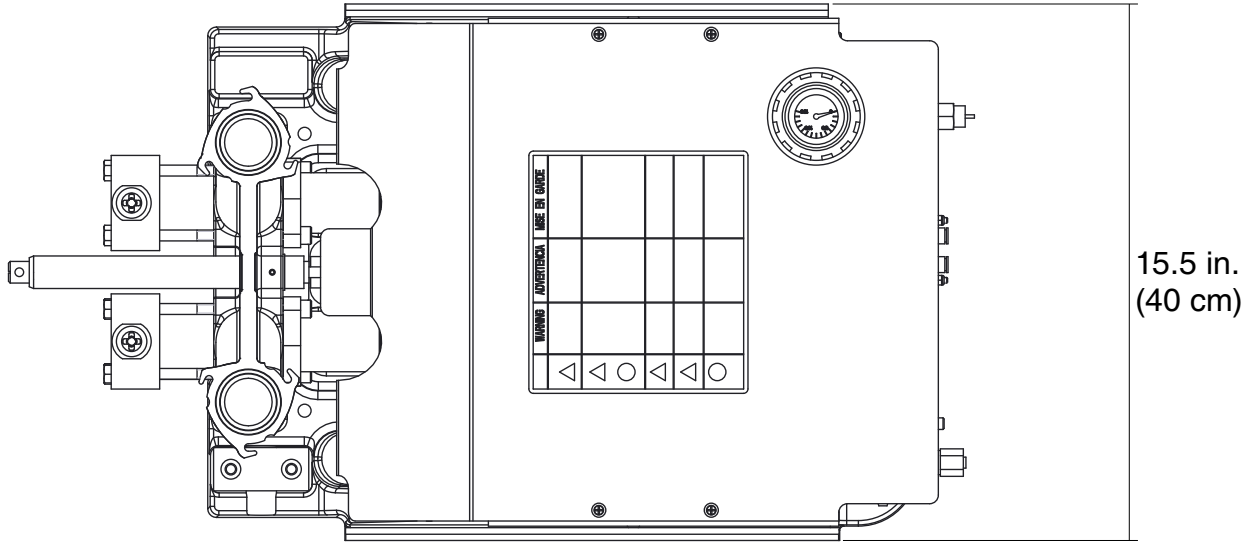

# Technical Data

PR70e		
	US	Metric
Metering Pump Effective Area	0.124 to 1.49 in. <sup>2</sup> per side	80 to 960 mm <sup>2</sup> per side
Small Air Cylinder Effective Area	7.07 in. <sup>2</sup>	4560 mm <sup>2</sup>
Large Air Cylinder Effective Area	15.9 in. <sup>2</sup>	10260 mm <sup>2</sup>
Maximum Stroke Length	1.50 in.	38.1 mm
Minimum Stroke Length	0.23 in.	5.8 mm
Air Volume per Cycle	0.12 to 4.3 in. <sup>3</sup>	2 to 70 cc
Pump Cycles per 1 L (0.26 gal)	14.3 to 500 cycles (varies by piston size)	
Ratios (fixed)	1.1 to 12:1 (depending upon cylinders selected)	
Maximum Fluid Working Pressure	3000 psi	20.7 MPa, 207 bar
Maximum Air Input Pressure	100 psi	0.7 MPa, 7 bar
Maximum Cycle Rate	30 cpm	
Compressed Air	Less than 10 scfm typical (varies with cycle times)	
Required Line Voltage	100-240 V 50/60 Hz, 1 phase - 50 Watts	
Machine Operation Voltage	24 VDC	
<b>Maximum Operating Temperature</b>		
Nylon pistons	160°F	70°C
UHMWPE pistons	120°F	50°C
<b>Noise (dBa)</b>		
Maximum sound pressure	82 dBa	
<b>Inlet/Outlet Sizes</b>		
Air inlet size	1/4 in. npt(f)	
Fluid outlet size	-03, -04, -06, -08 or -12 JIC fittings for 3/16 in. (4.8 mm), 1/4 in. (6.4 mm), 3/8 in. (9.5 mm), 1/2 in. (12.7 mm), 3/4 in. (19.1 mm) hoses	
<b>Materials of Construction</b>		
Wetted materials on all models	303/304, 17-4 PH, hard chrome, Chromex™, carbide, Chemical Resistant O-rings, PTFE, nylon, UHMWPE	
<b>Weight</b>		
All models	120 lb.	55 kg
<b>Notes</b>		
<i>Inhibiso® is a registered trademark of the Penetone Corp.</i>		
<i>Sound pressure measured 3.3 feet (1 meter) from equipment.</i>		
<i>Sound power measured per ISO-9614-2.</i>		



# Graco Standard Warranty

Graco warrants all equipment referenced in this document which is manufactured by Graco and bearing its name to be free from defects in material and workmanship on the date of sale to the original purchaser for use. With the exception of any special, extended, or limited warranty published by Graco, Graco will, for a period of twelve months from the date of sale, repair or replace any part of the equipment determined by Graco to be defective. This warranty applies only when the equipment is installed, operated and maintained in accordance with Graco's written recommendations.

This warranty does not cover, and Graco shall not be liable for general wear and tear, or any malfunction, damage or wear caused by faulty installation, misapplication, abrasion, corrosion, inadequate or improper maintenance, negligence, accident, tampering, or substitution of non-Graco component parts. Nor shall Graco be liable for malfunction, damage or wear caused by the incompatibility of Graco equipment with structures, accessories, equipment or materials not supplied by Graco, or the improper design, manufacture, installation, operation or maintenance of structures, accessories, equipment or materials not supplied by Graco.

This warranty is conditioned upon the prepaid return of the equipment claimed to be defective to an authorized Graco distributor for verification of the claimed defect. If the claimed defect is verified, Graco will repair or replace free of charge any defective parts. The equipment will be returned to the original purchaser transportation prepaid. If inspection of the equipment does not disclose any defect in material or workmanship, repairs will be made at a reasonable charge, which charges may include the costs of parts, labor, and transportation.

**THIS WARRANTY IS EXCLUSIVE, AND IS IN LIEU OF ANY OTHER WARRANTIES, EXPRESS OR IMPLIED, INCLUDING BUT NOT LIMITED TO WARRANTY OF MERCHANTABILITY OR WARRANTY OF FITNESS FOR A PARTICULAR PURPOSE.**

Graco's sole obligation and buyer's sole remedy for any breach of warranty shall be as set forth above. The buyer agrees that no other remedy (including, but not limited to, incidental or consequential damages for lost profits, lost sales, injury to person or property, or any other incidental or consequential loss) shall be available. Any action for breach of warranty must be brought within two (2) years of the date of sale.

**GRACO MAKES NO WARRANTY, AND DISCLAIMS ALL IMPLIED WARRANTIES OF MERCHANTABILITY AND FITNESS FOR A PARTICULAR PURPOSE, IN CONNECTION WITH ACCESSORIES, EQUIPMENT, MATERIALS OR COMPONENTS SOLD BUT NOT MANUFACTURED BY GRACO.** These items sold, but not manufactured by Graco (such as electric motors, switches, hose, etc.), are subject to the warranty, if any, of their manufacturer. Graco will provide purchaser with reasonable assistance in making any claim for breach of these warranties.

In no event will Graco be liable for indirect, incidental, special or consequential damages resulting from Graco supplying equipment hereunder, or the furnishing, performance, or use of any products or other goods sold hereto, whether due to a breach of contract, breach of warranty, the negligence of Graco, or otherwise.

## **FOR GRACO CANADA CUSTOMERS**

The Parties acknowledge that they have required that the present document, as well as all documents, notices and legal proceedings entered into, given or instituted pursuant hereto or relating directly or indirectly hereto, be drawn up in English. Les parties reconnaissent avoir convenu que la rédaction du présente document sera en Anglais, ainsi que tous documents, avis et procédures judiciaires exécutés, donnés ou intentés, à la suite de ou en rapport, directement ou indirectement, avec les procédures concernées.

# Graco Information

## Sealant and Adhesive Dispensing Equipment

For the latest information about Graco products, visit [www.graco.com](http://www.graco.com).

For patent information, see [www.graco.com/patents](http://www.graco.com/patents).

**TO PLACE AN ORDER, contact your Graco distributor, go to [www.graco.com](http://www.graco.com) and select "Where to Buy" in the top blue bar, or call to find the nearest distributor.**

***If calling from the US: 800-746-1334***

***If calling from outside the US: 0-1-330-966-3000***

*All written and visual data contained in this document reflects the latest product information available at the time of publication. Graco reserves the right to make changes at any time without notice.*

Original instructions. This manual contains English. MM 334135

**Graco Headquarters:** Minneapolis

**International Offices:** Belgium, China, Japan, Korea

**GRACO INC. AND SUBSIDIARIES • P.O. BOX 1441 • MINNEAPOLIS MN 55440-1441 • USA**

**Copyright 2014, Graco Inc. All Graco manufacturing locations are registered to ISO 9001.**

[www.graco.com](http://www.graco.com)

Revision F, August 2022