

# Bulldog<sup>®</sup> and Senator<sup>®</sup> Air Motor Tie Rod Kit

334131C

EN

*For connecting a long shaft displacement pump to a Graco Bulldog or Senator air motor.*

## Kit 24V750



### Important Safety Instructions

Read all warnings and instructions in this manual and in related manuals before using the equipment. Save these instructions.

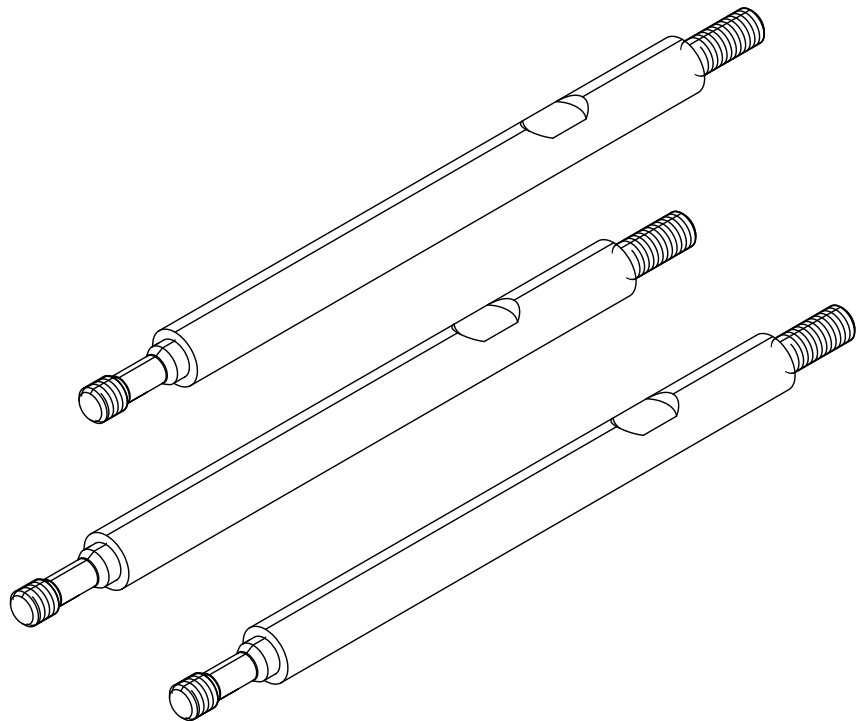

ti25519a

# Related Manuals

The following manuals are available at [www.graco.com](http://www.graco.com).

Manual in English	Description
334127	Check-Mate® 800 Displacement Pump (long shaft), Operation-Parts
311976	Therm-O-Flow® 20 System, Operation-Parts
311208	Therm-O-Flow® 200 System, Operation-Parts

## Installation

To connect a long shaft displacement pump to a Graco Bulldog or Senator air motor:

1. Remove the existing tie rods and install the tie rods (1) into the base of the air motor (B). Torque to 50–60 ft-lb (68–81 N•m).
2. Reuse the existing coupling nut (C) and the coupling collars (D). Ensure they are in place on the long shaft pump displacement rod (P).
3. Use at least two people to hold the displacement pump (G) while another connects it to the motor (B). Orient the pump's fluid outlet (E) to the air inlet (F) as shown. Position the long shaft displacement pump (G) on the tie rods (A).
4. Screw the nuts (H) onto the tie rods (1) and torque to 50–60 ft-lb (61–81 N•m).
5. Screw the coupling nut (C) onto the motor shaft (J) loosely. Hold the motor shaft flats with a wrench to keep it from turning. Use an adjustable wrench to tighten the coupling nut. Torque to 145–155 ft-lb (196–210 N•m).
6. Connect all hoses. Connect the ground wire.
7. Fill the wetcup (W) 2/3 full with Graco Throat Seal Liquid (TSL™) for Butyl and PSA materials.

**NOTE:** Use IsoGuard Select® (IGS) (part 24F516) for PUR or reactive Polyurethane material. IGS is

designed to dissolve and suspend the Polyurethane materials. IGS will solidify after a period of time and should be replaced once the solidified lube does not return to liquid form after heating.

8. If there is material already in the pump, you must warm up the system for 30–60 minutes before running the pump. Open the gun before heating the system.
9. Turn on the air supply. Run the pump slowly to ensure proper operation.

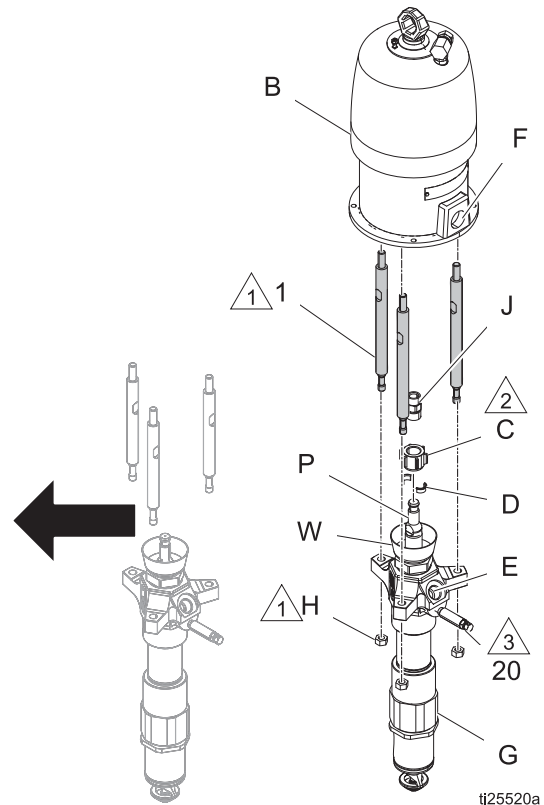

- 1 Torque to 50-60 ft-lb (61-81 N•m).
- 2 Torque to 145-155 ft-lb (196-210 N•m).
- 3 Bleed hole must face down.

## Parts

Ref.	Part	Description	Qty.
1	17B435	ROD, tie, vertical driver	3



# Graco Information

## Sealant and Adhesive Dispensing Equipment

For the latest information about Graco products, visit [www.graco.com](http://www.graco.com).

For patent information, see [www.graco.com/patents](http://www.graco.com/patents).

TO PLACE AN ORDER, contact your Graco distributor, go to [www.graco.com](http://www.graco.com), or call to identify the nearest distributor.

If calling from the USA: 1-800-746-1334

If calling from outside the USA: 0-1-330-966-3000

*All written and visual data contained in this document reflects the latest product information available at the time of publication.  
Graco reserves the right to make changes at any time without notice.*

Original instructions. This manual contains English. MM 3A1974

**Graco Headquarters:** Minneapolis

**International Offices:** Belgium, China, Japan, Korea

**GRACO INC. AND SUBSIDIARIES • P.O. BOX 1441 • MINNEAPOLIS MN 55440-1441 • USA**  
Copyright 2020, Graco Inc. All Graco manufacturing locations are registered to ISO 9001.

[www.graco.com](http://www.graco.com)  
Revision C, April 2020