

G3[®] Standard Automatic Lubrication Pump

332291V

EN

For dispensing NLGI Grades #000 to #2 greases and oils with at least 40cSt. For professional use only.

Not approved for use in explosive atmospheres or hazardous (classified) locations.

Part Nos., page 3

5100 psi (35.1 MPa, 351.6 bar) Pump Output Pressure

5000 psi (34.3 MPa, 344.8 bar) Fill Inlet Pressure



Important Safety Instructions

Read all warnings and instructions in this manual before using the equipment.
Save these instructions.

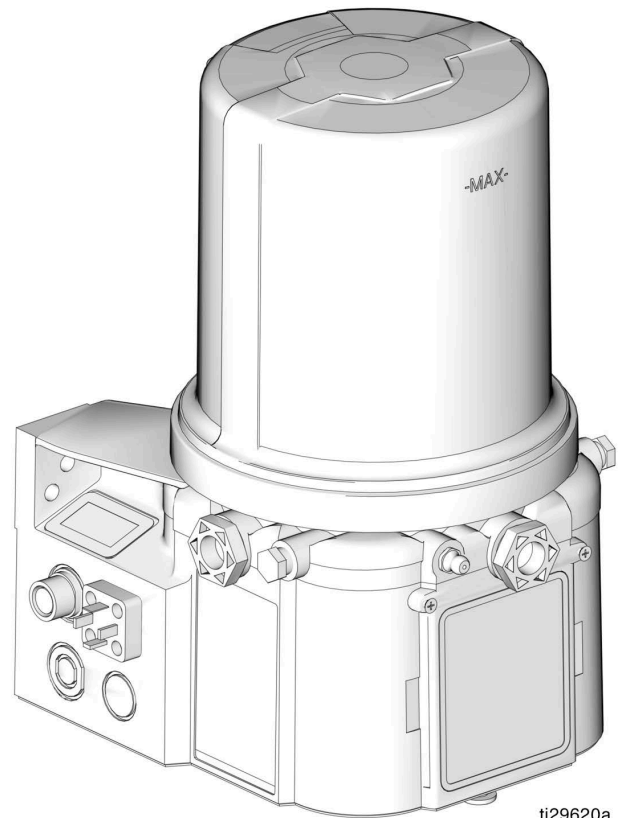

ti29620a



Conforms to ANSI/UL 73
Certified to CAN/CSA
Std. 22.2 No 68-09



Intertek
3132066

110-240VAC Pumps ONLY

PROVEN QUALITY. LEADING TECHNOLOGY.

Contents

Part / Model Numbers	3
2 Liter Models	3
4 Liter Models	3
8 Liter Models	4
12 Liter Models	4
16 Liter Models	4
Understanding the Model Number	5
Warnings	6
Installation	9
Typical Installation	10
Typical Installation - With Remote	
Fill Manifold	11
Optional Installation - Without Remote	
Fill Manifold	12
Choose an Installation Location	13
System Configuration and Wiring	13
Setup	19
Pressure Relief Procedure	19
Connect to Auxiliary Fittings	19
Set Pump Outlet Volume	20
Fill Reservoir - Grease Dispense Pumps	20
Auto-Fill Shut Off	23
Fill Reservoir - Oil Dispense Pumps	26
Prime the Pump	26
Pump Operation	27
Recycling and Disposal	29
End of Product Life	29
Troubleshooting	30
Maintenance	31
Parts - 2 Liter Models	32
Parts - 4 Liter and Larger Models	33
Parts	34
Dimensions	37
Mounting Pattern	38
Technical Specifications	39
California Proposition 65	39
Graco Standard Warranty	40

Part / Model Numbers

The Part Number is a six-digit unique number that is only used to order the G3 Pump. Directly related to this six digit Part Number is the configured Graco Model Number. This configured number identifies the distinct features of a specific G3 Pump. To help you understand each component that makes up the Model Number see **Understanding the Model Number**, page 5. The tables below shows the relationship between each Part Number and its related Model Number.

2 Liter Models

Part Numbers	Model Number	
96G000	G3-G-12NC-2L0000-00C00000	
96G001	G3-G-24NC-2L0000-00C00000	
96G002	G3-G-ACNC-2L0000-0D000000	X
96G003	G3-G-12NC-2L0A00-L0C00000	
96G005	G3-G-24NC-2L0A00-L0C00000	
96G006	G3-G-24NC-2LFA00-L0C00000	
96G007	G3-G-ACNC-2L0A00-LD000000	X
96G008	G3-G-ACNC-2LFA00-LD000000	X
96G050	G3-A-24NC-2L0A00-L0C00000	
96G059	G3-A-ACNC-2L0A00-LD000000	X
96G182	G3-G-24NC-2L0A00-0D00L000	
96G239	G3-G-24NC-2L0A06-00C00000	
96G243	G3-G-24NC-2L0A00-0D00L000	
96G261	G3-G-24NC-2L0A07-L0C00000	
96G319	G3-G-12NC-2LFA00-L0C00000	
96G320	G3-G-ACNC-2LFA00-0D00L000	
96G325	G3-G-12NC-2L0A07-L0C00000	
96G327	G3-G-ACNC-2L0A07-LD000000	X

4 Liter Models

Part Numbers	Model Number	
96G038	G3-G-12NC-4L0L00-00C00000	
96G040	G3-G-24NC-4L0000-00C00000	
96G042	G3-G-ACNC-4L0000-0D000000	X
96G044	G3-G-12NC-4L0A00-L0C00000	
96G048	G3-G-24NC-4L0A00-L0C00000	
96G051	G3-A-24NC-4L0A00-L0C00000	
96G053	G3-G-24NC-4LFA00-L0C00000	
96G055	G3-G-ACNC-4L0A00-LD000000	X
96G060	G3-A-ACNC-4L0A00-LD000000	X
96G062	G3-G-ACNC-4LFA00-LD000000	X
96G173	G3-G-ACNC-4LFA00-0D00L000	X
96G179	G3-G-ACNC-4LFA00-0D00L000	X
96G184	G3-G-24NC-4L0A00-0D00L000	
96G210	G3-G-24NC-4LAA00-0D00L000	
96G180	G3-G-24NC-4L0A02-L0C00000	
96G202	G3-G-ACNC-4L0A00-0D00L000	X
96G204	G3-G-24NC-4LFA00-0D00L000	
96G238	G3-G-24NC-4L0A06-00C00000	
96G248	G3-G-24NC-4L0A02-L0C00000	
96G250	G3-G-24NC-4LFA07-0D00L000	
96G273	G3-G-12NC-4L0A10-00C00000	
96G276	G3-G-24NC-4L0A07-0D00L000	
96G278	G3-G-24NC-4LHA06-00C00000	
96G280	G3-G-24NC-4LHA00-0D00L000	
96G287	G3-G-24NC-4L0A10-00C00000	
96G321	G3-G-ACNC-4LFA00-0D00L000	
96G331	G3-G-12NC-4L0A06-00C00000	

8 Liter Models

Part Numbers	Model Number	
96G039	G3-G-12NC-8L0000-00C00000	
96G041	G3-G-24NC-8L0000-00C00000	
96G043	G3-G-ACNC-8L0000-0D000000	X
96G045	G3-G-12NC-8L0A00-L0C00000	
96G049	G3-G-24NC-8L0A00-L0C00000	
96G052	G3-A-24NC-8L0A00-L0C00000	
96G056	G3-G-ACNC-8L0A00-LD000000	X
96G061	G3-A-ACNC-8L0A00-LD000000	X
96G187	G3-G-ACNC-8LFA00-0D00L000	X
96G189	G3-G-24NC-8L0A00-0D00L000	
96G192	G3-G-24NC-8LFA00-L0C00000	
96G198	G3-G-24NC-8L0A06-0C000000	
96G207	G3-G-ACNC-8LAA00-LD000000	X
96G213	G3-G-24NC-8LAA00-0D00L000	
96G217	G3-G-24NC-8LAA06-00C00000	
96G205	G3-G-24NC-8LFA00-0D00L000	
96G233	G3-G-12NC-8L0A00-0D00L000	
96G249	G3-G-24NC-8L0A07-0D00L000	
96G251	G3-G-24NC-8LFA07-0D00L000	
96G271	G3-G-24NC-8LFA07-00C00000	
96G272	G3-G-24NC-8LFA10-00C00000	
96G279	G3-G-24NC-8LHA06-00C00000	
96G281	G3-G-24NC-8LHA00-0D00L000	
96G290	G3-G-24NC-8LAA10-00C00000	
96G322	G3-G-ACNC-8LFA00-0D00L000	
96G332	G3-G-12NC-8L0A06-00C00000	

12 Liter Models

Part Numbers	Model Number	
96G057	G3-G-ACNC-120A00-LD000000	X
96G171	G3-G-24NC-120000-00C00000	
96G199	G3-G-24NC-120A00-L0C00000	
96G240	G3-G-24NC-120A00-0D00L000	

16 Liter Models

Part Numbers	Model Number	
96G058	G3-G-ACNC-160A00-LD000000	X
96G172	G3-G-24NC-160000-00C00000	
96G220	G3-G-24NC-160A00-L0C00000	
96G230	G3-G-12NC-160A00-0D000000	
96G237	G3-G-ACNC-16AA00-LD000000	X
96G241	G3-G-24NC-160A00-0D00L000	
96G258	G3-A-24NC-160A00-L0C00000	
96G291	G3-A-ACNC-160A00-LD000000	X

Understanding the Model Number

Use the Code Sample provided below to identify each component's location in the Model Number. The options for each component that make up the code are provided on the lists below.

NOTE: Other pump configurations are available that are not documented in this manual. Contact Graco Customer Service or your local Graco distributor for assistance.

Code Sample: $\frac{G}{a} \frac{3}{b} - \frac{-}{b} - \frac{N}{c} \frac{C}{c} - \frac{d}{d} \frac{e}{e} \frac{f}{f} \frac{0}{g} \frac{0}{g} - \frac{h}{h} \frac{i}{i} \frac{j}{j} \frac{0}{k} \frac{0}{m} \frac{0}{n} \frac{0}{p} \frac{0}{q}$

Code a: Pump Fluid Type

- G = Grease
- A = Oil

Code bb: Power Source

- 12 = 12 Volts DC
- 24 = 24 Volts DC
- AC = 100 - 240 Volts AC

Code cc: Operation Control

- NC = No Controller

Code dd: Reservoir Capacity (Liters)

- 2L = 2 Liters
- 4L = 4 Liters
- 8L = 8 Liters
- 12 = 12 Liters
- 16 = 16 Liters

Code e: Reservoir Feature

- F = Follower Plate Installed
- 0 = No Follower Plate
- A = Auto-Fill Shut Off
- L = Top Fill
- H = Hammer Pump

Code f: Low Level Option

- A = External Low Level
- 0 = No Low Level monitoring

Code gg: Options

- 00 = No Options
- 06 = Low Level in CPC

Code h, i, j, k, m, n, p, q

NOTE: Codes h - q relate to a specific location on the G3 pump. See Fig. 1 for these locations.

- C = CPC
- D = DIN
- L = Low Level
- 0 = Not populated

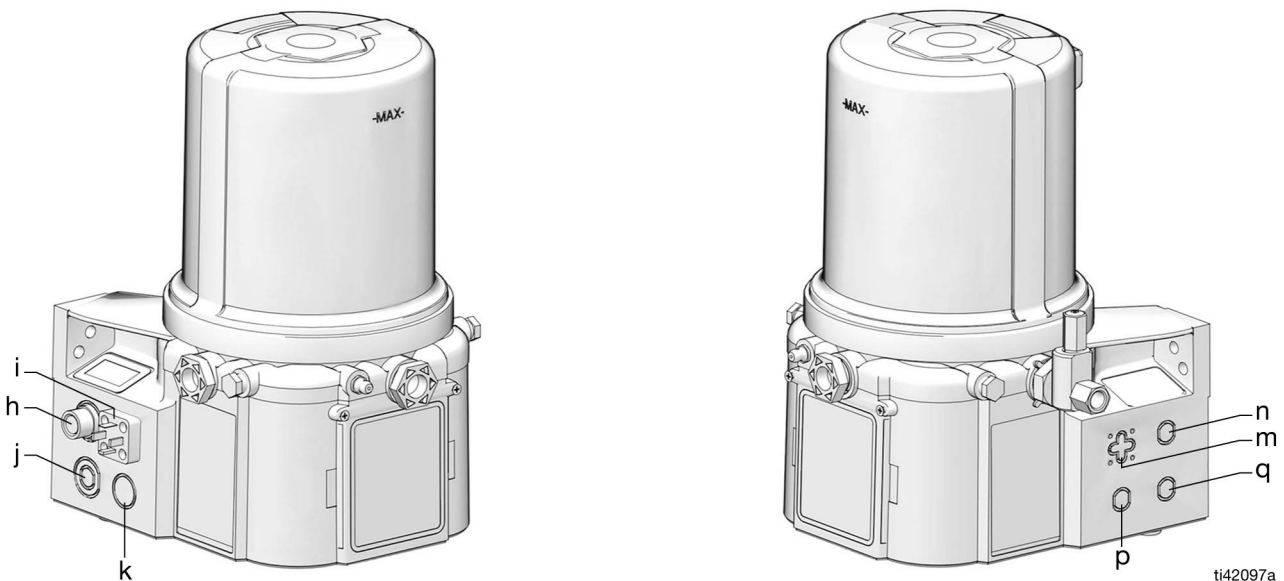









FIG. 1

Warnings

The following warnings are for the setup, use, grounding, maintenance, and repair of this equipment. The exclamation point symbol alerts you to a general warning and the hazard symbols refer to procedure-specific risks. When these symbols appear in the body of this manual or on warning labels, refer back to these Warnings. Product-specific hazard symbols and warnings not covered in this section may appear throughout the body of this manual where applicable.

 <h1 style="margin: 0;">WARNING</h1>	
 	<p>ELECTRIC SHOCK HAZARD</p> <p>This equipment must be grounded. Improper grounding, setup, or usage of the system can cause electric shock.</p> <ul style="list-style-type: none"> • Turn off and disconnect power at main switch before disconnecting any cables and before servicing or installing equipment. • Connect only to grounded power source. • All electrical wiring must be done by a qualified electrician and comply with all local codes and regulations.
 	<p>EQUIPMENT MISUSE HAZARD</p> <p>Misuse can cause death or serious injury.</p> <ul style="list-style-type: none"> • Do not operate the unit when fatigued or under the influence of drugs or alcohol. • Do not exceed the maximum working pressure or temperature rating of the lowest rated system component. See Technical Specifications in all equipment manuals. • Use fluids and solvents that are compatible with equipment wetted parts. See Technical Specifications in all equipment manuals. Read fluid and solvent manufacturer’s warnings. For complete information about your material, request Safety Data Sheets (SDSs) from distributor or retailer. • Turn off all equipment and follow the Pressure Relief Procedure when equipment is not in use. • Check equipment daily. Repair or replace worn or damaged parts immediately with genuine manufacturer’s replacement parts only. • Do not alter or modify equipment. Alterations or modifications may void agency approvals and create safety hazards. • Make sure all equipment is rated and approved for the environment in which you are using it. • Use equipment only for its intended purpose. Call your distributor for information. • Route hoses and cables away from traffic areas, sharp edges, moving parts, and hot surfaces. • Do not kink or over bend hoses or use hoses to pull equipment. • Keep children and animals away from work area. • Comply with all applicable safety regulations.

! WARNING

	<p>SKIN INJECTION HAZARD High-pressure fluid from dispensing device, hose leaks, or ruptured components will pierce skin. This may look like just a cut, but it is a serious injury that can result in amputation. Get immediate surgical treatment.</p> <ul style="list-style-type: none"> • Do not point dispensing device at anyone or at any part of the body. • Do not put your hand over the fluid outlet. • Do not stop or deflect leaks with your hand, body, glove, or rag. • Follow the Pressure Relief Procedure when you stop dispensing and before cleaning, checking, or servicing equipment. • Tighten all fluid connections before operating the equipment. • Check hoses and couplings daily. Replace worn or damaged parts immediately.
	<p>PRESSURIZED EQUIPMENT HAZARD Over-pressurization can result in equipment rupture and serious injury.</p> <ul style="list-style-type: none"> • A pressure relief valve is required at each pump outlet. • Follow the Pressure Relief Procedure in this manual before servicing.
	<p>PLASTIC PARTS CLEANING SOLVENT HAZARD Many cleaning solvents can degrade plastic parts and cause them to fail, which could cause serious injury or property damage.</p> <ul style="list-style-type: none"> • Use only compatible solvents to clean plastic structural or pressure-containing parts. • See Technical Specifications in all equipment manuals for materials of construction. Consult the solvent manufacturer for information and recommendations about compatibility.

WARNING



MOVING PARTS HAZARD

Moving parts can pinch, cut or amputate fingers and other body parts.

- Keep clear of moving parts.
- Do not operate equipment with protective guards or covers removed.
- Equipment can start without warning. Before checking, moving, or servicing equipment, follow the **Pressure Relief Procedure** and disconnect all power sources.



PERSONAL PROTECTIVE EQUIPMENT

Wear appropriate protective equipment when in the work area to help prevent serious injury, including eye injury, hearing loss, inhalation of toxic fumes, and burns. Protective equipment includes but is not limited to:

- Protective eyewear, and hearing protection.
- Respirators, protective clothing, and gloves as recommended by the fluid and solvent manufacturer.

Installation

Component Identification

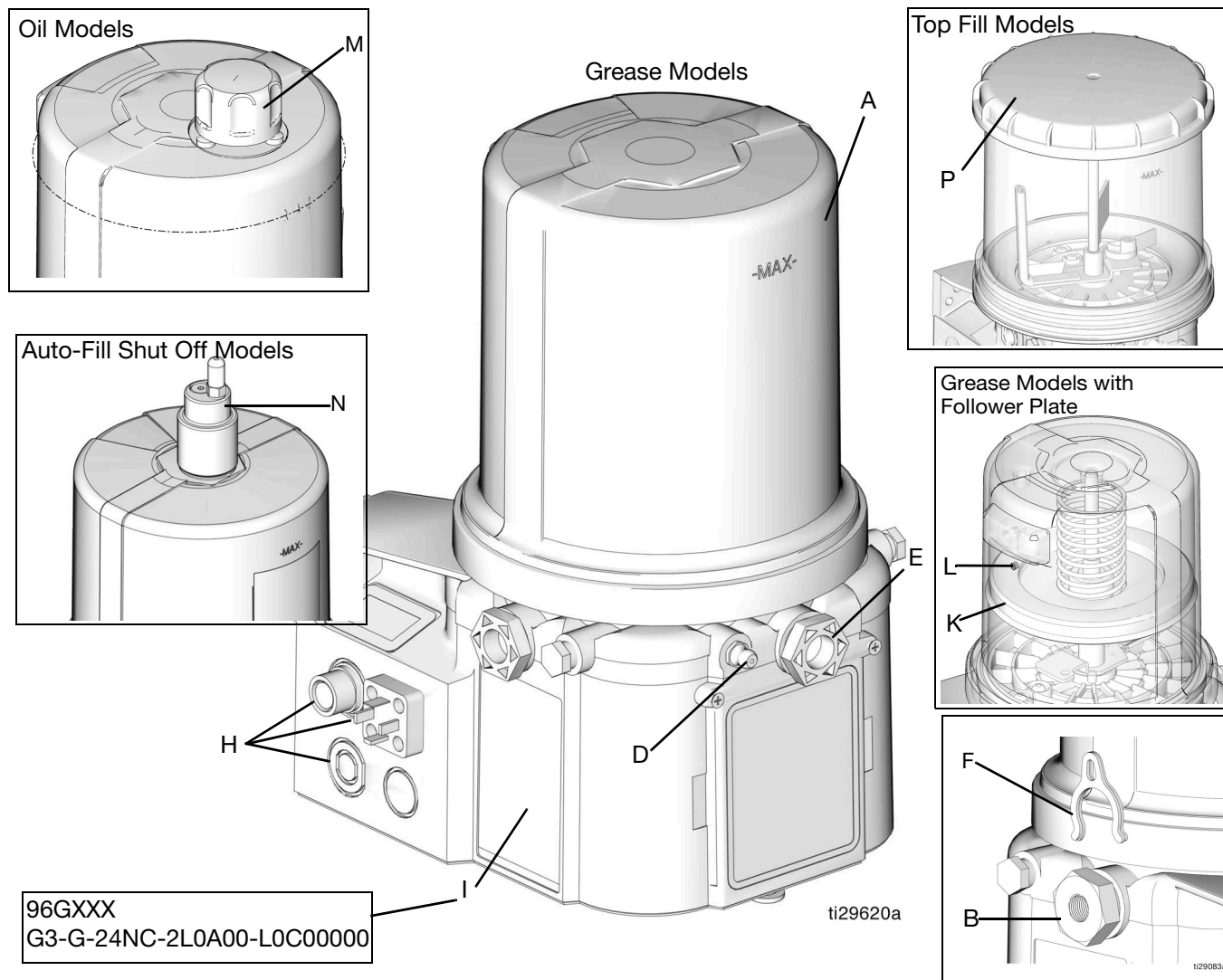

FIG. 2

Key:

- | | |
|---|--|
| <ul style="list-style-type: none"> A Reservoir B Adjustable Pump Element (1 included. Can accommodate 3 total) C Pressure Relief Valve (Not included (not shown) / required for each outlet - Available from Graco. See Parts, page 35.) D Zerk Inlet Fill Fitting (1 included / grease models only) E Pump Outlet Plug (2 included) F Volume Control Spacers (2 included. More spacers = less output volume per stroke) (also see FIG. 18, page 20) G Fuse (DC models only - Not included, not shown. Available from Graco. See Parts, page 34.) H Power / Sensor Panel (both sides; only one side shown) I Part Number / Model Number example only shown, (see page 5, Understanding the Model Number, for details) | <ul style="list-style-type: none"> J Power Cord (Not shown) K Follower Plate (grease models only / not available on all grease models) L Vent Hole for Follower Plate (grease models only / not available on all grease models) M Fill cap (oil models only) N Auto-Fill Shut Off P Top Fill Lid |
|---|--|

Typical Installation

Series Progressive Divider Valve

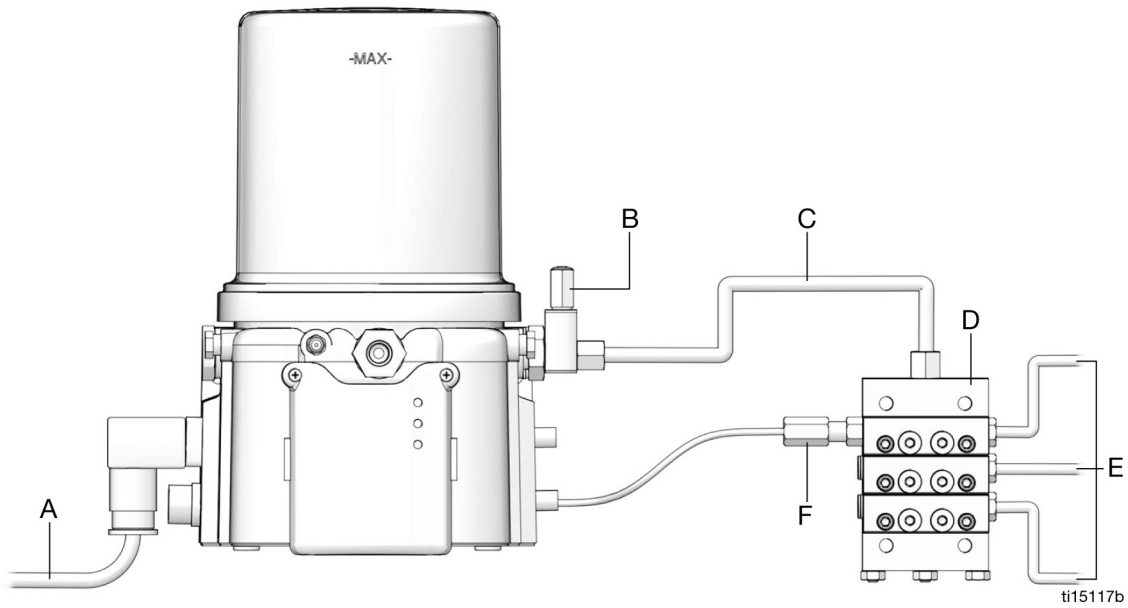

FIG. 3

Injector Installations

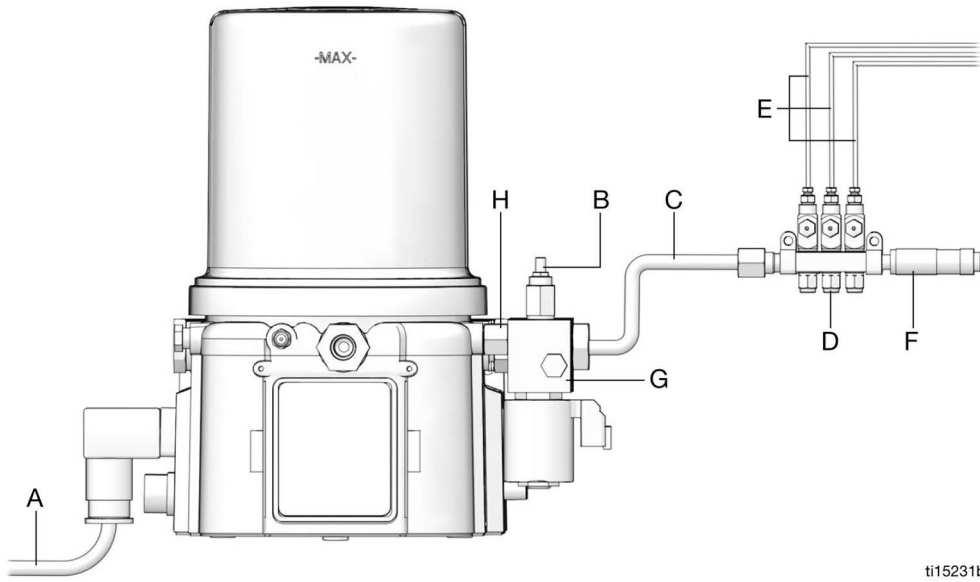

FIG. 4

Key

- | | |
|---|--|
| <p>A Connected to fused power source</p> <p>B Pressure relief valve (Not included/ required for each outlet - user supplied. See Parts, page 35)</p> <p>C Supply Hose (user supplied)</p> <p>D Series progressive divider valves (Divider Installations)
- Injectors (Injector Installations)</p> | <p>E To lube points</p> <p>F - Proximity Switch (Divider Installations)
- Pressure switch (Injector Installations)</p> <p>G Vent valve (Not included / available from Graco. See Parts, page 36.)</p> <p>H Return to reservoir</p> |
|---|--|

Typical Installation - With Remote Fill Manifold

The installation shown is only a guide for selecting and installing system components. Contact your Graco distributor for assistance in planning a system to suit your needs.

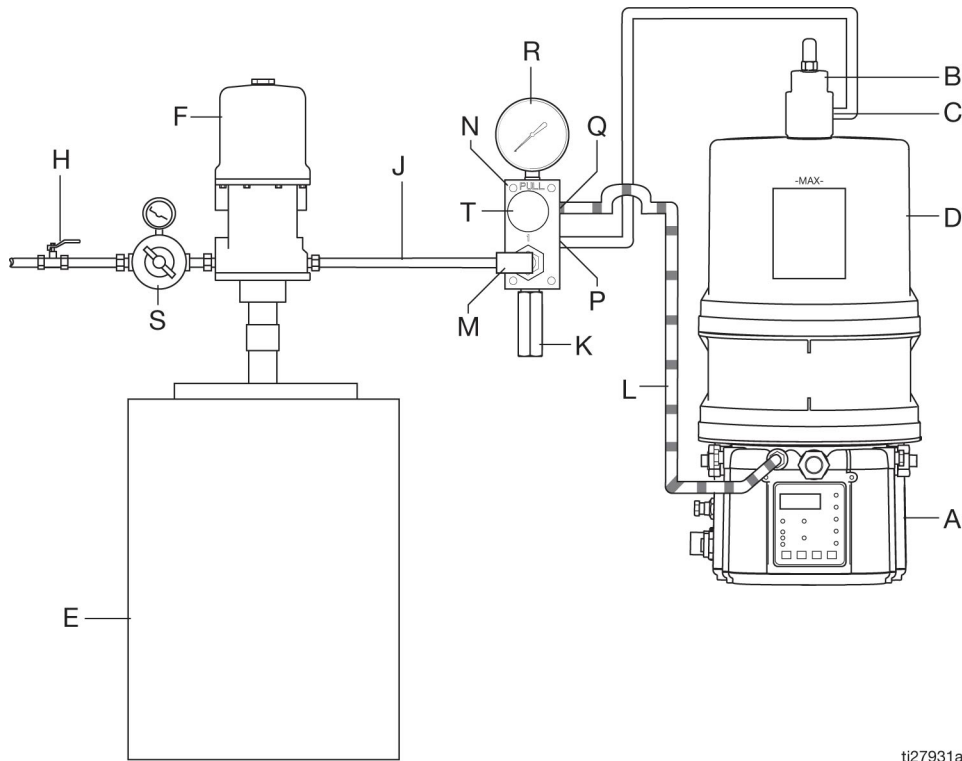

ti27931a

FIG. 5

Key:

- A G3 Pump
- B Auto-Fill Shut Off Valve
- C Auto-Fill Inlet
- D G3 Reservoir
- E Remote Fill Reservoir
- F Remote Fill Pump
- G Supply Hose (user supplied)
- H Air Supply to Refill Pump
- J Supply Hose (user supplied)
- K Pressure Relief Valve
- L Drain Hose
- M Fill Coupler/Inlet (quick disconnect)
- N Fill Manifold❖
- P Fill Manifold Outlet
- Q Fill Manifold Vent Port
- R Pressure Gauge
- S Pressure Regulator and Gauge
- T Pressure Relief Knob

❖ To relieve the stall pressure in the fill line a fill manifold (N) must be installed in the system.

Optional Installation - Without Remote Fill Manifold

The installation shown is only a guide for selecting and installing system components. Contact your Graco distributor for assistance in planning a system to suit your needs.

NOTE: The remote filling station pump stalls (dead-heads) when the reservoir is full. If the pump does not stall (dead-head) there is a leak in the system.

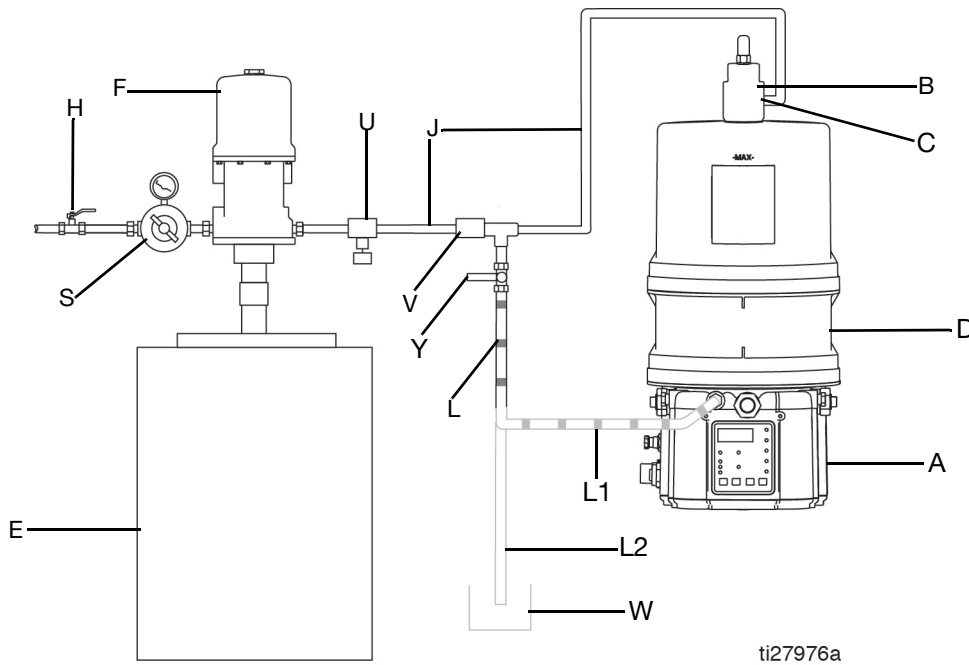

ti27976a

FIG. 6

Key:

- A G3 Pump
- B Auto-Fill Shut Off Valve
- C Auto-Fill Inlet
- D G3 Reservoir
- E Remote Fill Reservoir
- F Remote Fill Pump
- H Relief Valve
- J Supply Hose (user supplied)
- L Drain Tube
 - L1 Option - To reservoir
 - L2 Option - To overflow container
- S Pressure Regulator and Gauge
- U Pressure Relief Valve
- V Quick Disconnect
- W Overflow Container
- Y Supply Hose Pressure Relief Valve❖

❖ To relieve the stall pressure in the fill line a ball valve (Y) must be installed in the system.

Choose an Installation Location



AUTOMATIC SYSTEM ACTIVATION HAZARD

The system is equipped with an automatic timer that activates the pump lubrication system when power is connected or when exiting the programming function. Unexpected activation of the system could result in serious injury, including skin injection and amputation.

Before you install or remove the lubrication pump from the system, disconnect and isolate all power supplies and relieve all pressure.

- Select a location that will adequately support the weight of the G3 Pump and lubricant, as well as all plumbing and electrical connections.
- Refer to the mounting hole layouts provided in the **Mounting Pattern** section of this manual, page 38. No other installation configuration should be used.
- Use designated mounting holes and provided configurations only.
- Always mount the G3 oil models upright.
- Mount top fill G3 pump models so that there is a minimum clearance of four inches (4.0 in.) (10.2 cm) above the reservoir to allow for lid removal and filling.
- If the G3 grease model is going to be operated in a tilted or inverted position for any period of time, you must use a model that includes a follower plate, otherwise the G3 must be mounted upright. Refer to your model number to confirm if a follower plate was installed on your pump. See page 5, **Understanding the Model Number** to identify this character in your model number.
- Use the three fasteners (included) to secure the G3 to the mounting surface.
- Some installations may require an additional reservoir support bracket. See table below for bracket information.
- In high vibration environments, additional isolation at mounting point is necessary. See table below.

- AC pumps are not recommended when high vibration or shock is present.

Part No	Description
571159	Reservoir bracket and strap
125910	L-Bracket for pump
127665	USP to G-Series mounting bracket
132187	Isolator mounting kit

System Configuration and Wiring

Grounding

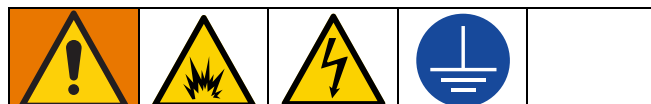

The equipment must be grounded to reduce the risk of static sparking and electric shock. Electric or static sparking can cause fumes to ignite or explode. Improper grounding can cause electric shock. Grounding provides an escape wire for the electric current.

Improper installation of the grounding conductor may result in a risk of electric shock. This product must be installed by a qualified electrician in compliance with all state and local codes and regulations.

If the product is permanently connected, it must be:

- installed by a qualified electrician or serviceman.
- connected to a grounded, permanent wiring system.

If an attachment plug is required in the end use application:

- it must be rated for the product electrical specifications.
- it must be an approved, 3-wire grounding type attachment plug.
- it must be plugged into an outlet that is properly installed and grounded in accordance with all local codes and ordinances.
- when repair or replacement of the power cord or plug is required, do not connect the grounding wire to either flat blade terminal.

Fuses

NOTICE
<p>Fuses (user supplied) are required on all DC models. To avoid equipment damage:</p> <ul style="list-style-type: none"> • Never operate G3 Pump DC models without a fuse installed. • A fuse of the correct current must be installed in line with the power entry to the system.

Fuse Kits are available from Graco. The following Table identifies the correct fuse to use for the input voltage and the corresponding Graco Kit number.



Input Voltage	Fuse Value	Graco Kit No.
12 VDC	7.5 A	571039
24 VDC	4 A	571040

Recommendations for Using Pump in Harsh Environments

- Use pump with CPC style power cable.
- If using a DIN style power or alarm harness with a right angle mating connector, make sure the connector does not exit the unit in the UP direction.
- Use a corrosion preventative electrical grease on all contacts.

Wire and Installation Diagrams

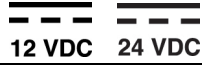
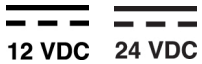
The following table identifies the wiring and installation diagrams for the cables included with the pump.

Diagram	Symbol	Page
Power DIN AC	 AC	14
Power DIN DC	 12 VDC 24 VDC	15
Power CPC DC	 12 VDC 24 VDC	15
Low Level Outputs		16



Power DIN AC - 15 foot

AC

Pin and Related Wire Color (FIG. 7)

Pin	Pin Name	Color
1	Line	Black
2	Neutral	White
3	Not Used	Not Used
	Ground	Green

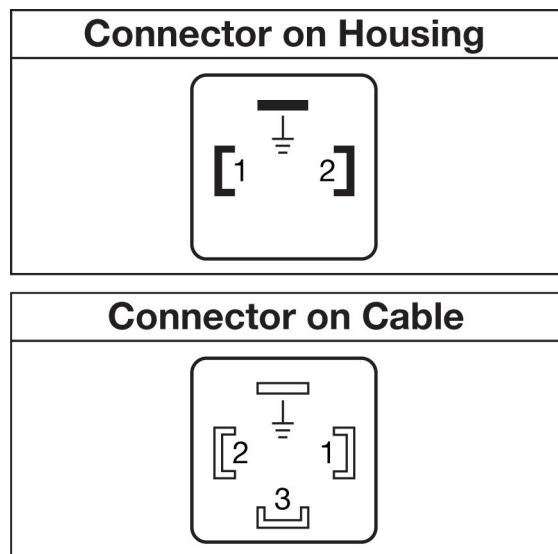

ti27630b

FIG. 7

12 VDC 24 VDC Power DIN DC - 15 foot

12 VDC 24 VDC Power CPC DC - 15 foot

Pin and Related Wire Color (FIG. 8)

Pin and Related Wire Color (FIG. 9)

Pin	Pin Name	Color
1	-VDC	Black
2	+VDC	White
3	Not Used	Not Used
	Not Used	Green

Pin	Pin Name	Color
1	Not Used	Not Used
2	-VDC	Black
3	+VDC	White
4	Not Used	Not Used
5	Not Used	Not Used
6	Not Used	Not Used
7	Not Used	Not Used

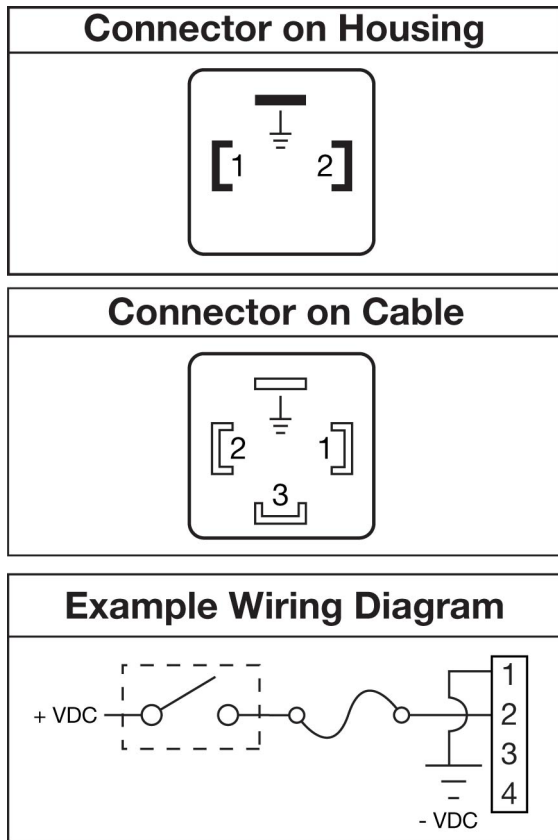

FIG. 8

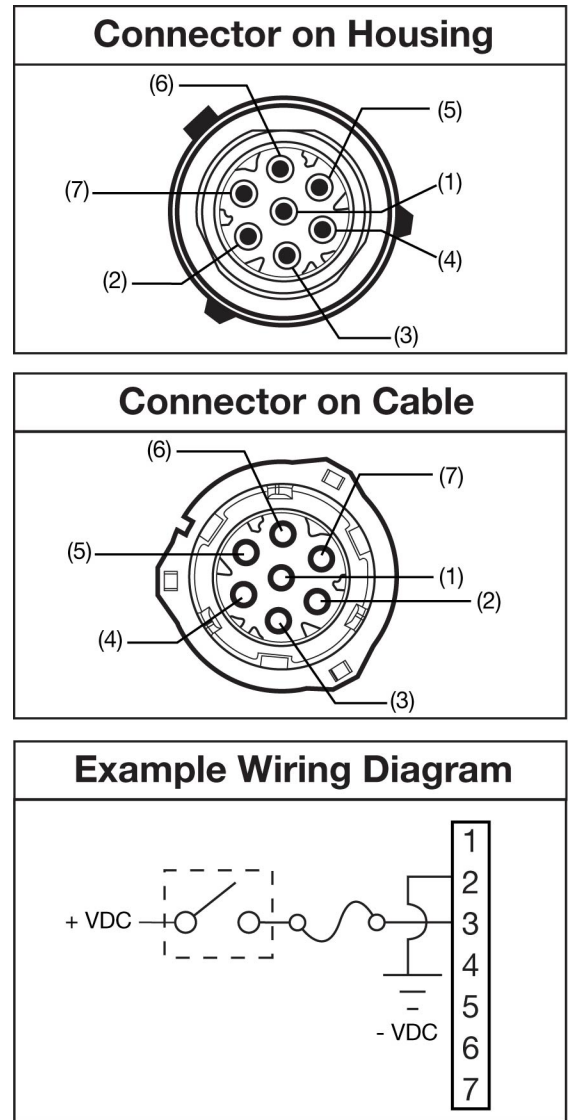

FIG. 9

12 VDC 24 VDC Power CPC DC - With Low Level

Pin and Related Wire Color (FIG. 10)

Pin	Pin Name	Color
1	Not Used	Not Used
2	-VDC	Black
3	+VDC	Red
4	LL N.O.	White or Yellow
5	LL COM	Orange
6	Not Used	Not Used
7	Not Used	Green or Blue

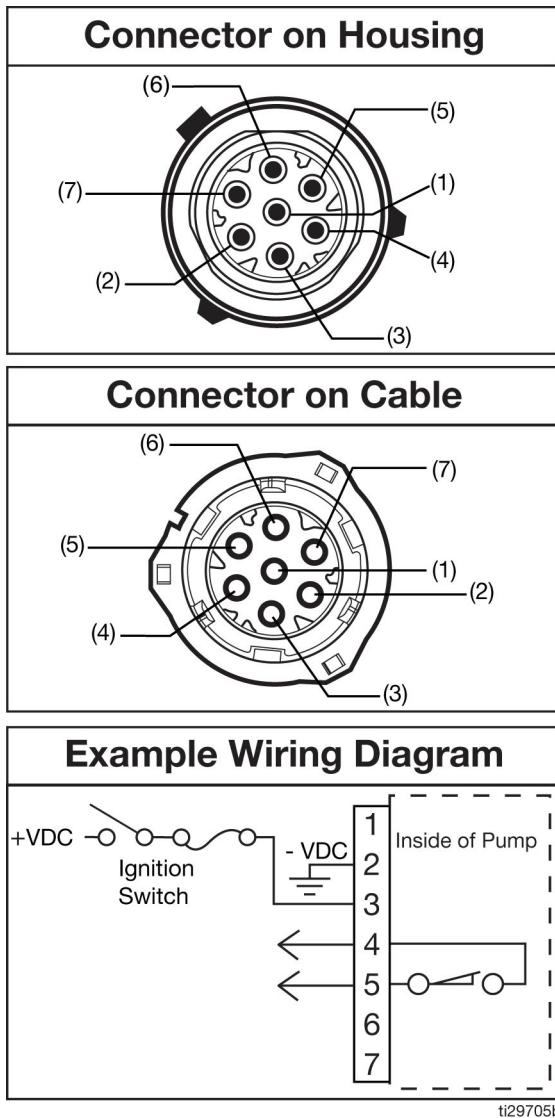

FIG. 10

Low Level Outputs

See Low Level Output Option, page 27 for functional description. See **Technical Specifications**, page 39 for ratings.

Pins (FIG. 11)

Pin	Pin Name
1	Not Used
2	Not Used
3	LL N.O.
4	LL COM

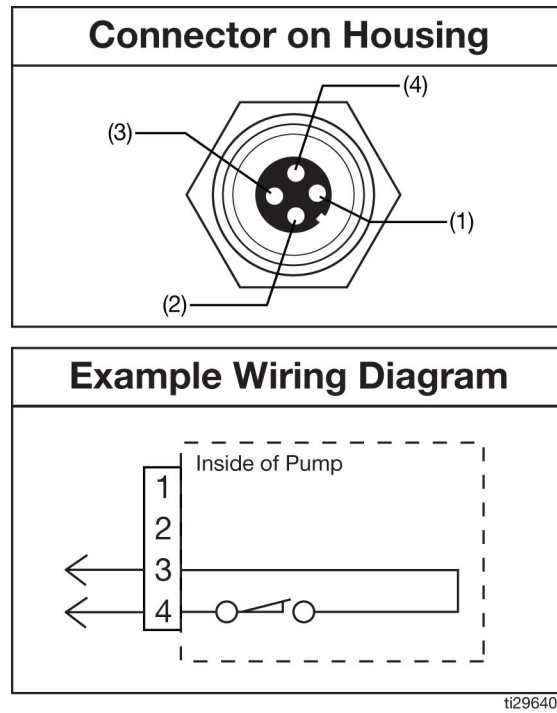
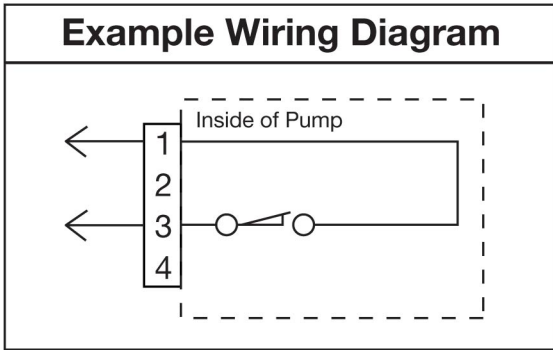
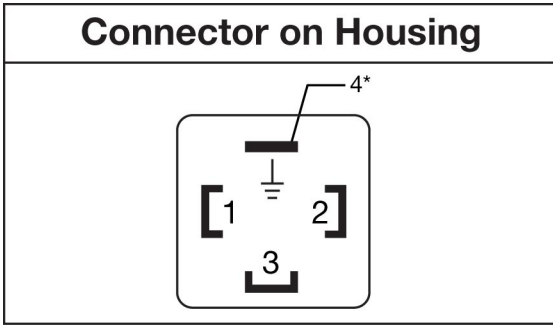

FIG. 11

Pins (FIG. 12)

Pin	Pin Name
1	LL N.O.
2	Not Used
3	LL COM
4	Not Used



ti29639b

FIG. 12

Part No. 124333: Cable Pin Out (M12)

Wire Colors (FIG. 13)

Item No.	Color
1	Brown
2	White
3	Blue
4	Black

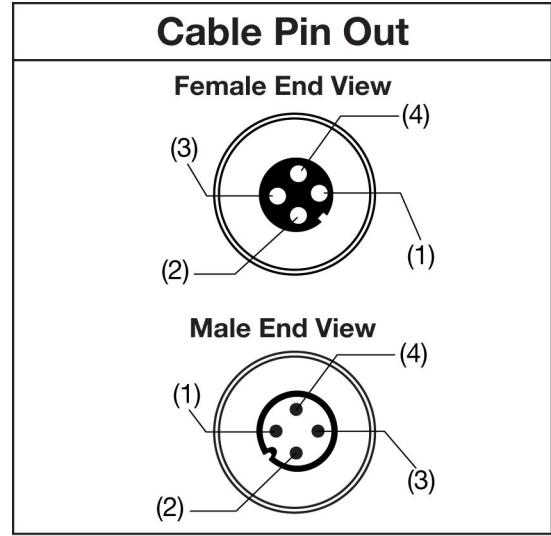

ti27634b

FIG. 13

Part No. 124300: Field Wireable Pin Out (M12)

Wire Colors (FIG. 14)

Item No.	Color
1	Brown
2	White
3	Blue
4	Black

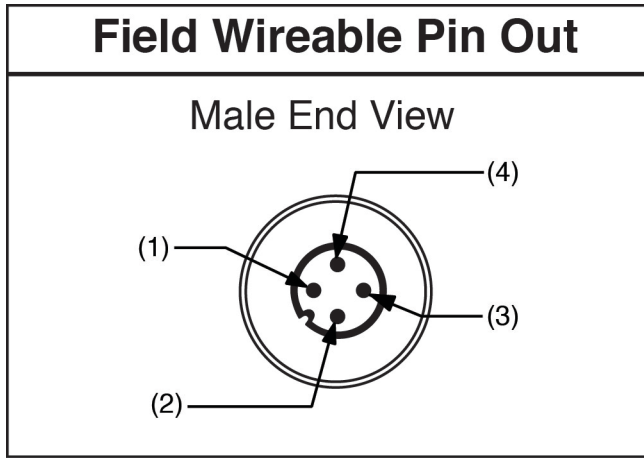

ti27635a

FIG. 14

Part No. 124594: 4 Pin Eurofast Male Field Wireable Connector (FIG. 15)

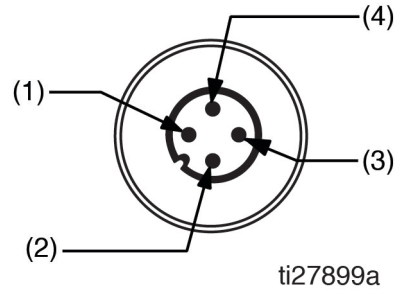

FIG. 15

Part No. 124595: 5 Pin Eurofast Male Field Wireable Connector (FIG. 16)

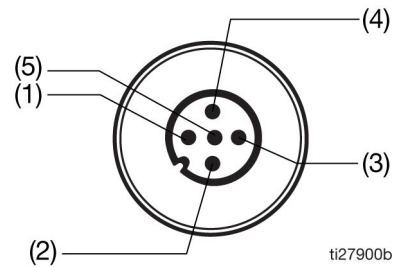

FIG. 16

Setup

Pressure Relief Procedure



Follow the Pressure Relief Procedure whenever you see this symbol.



This equipment stays pressurized until pressure is manually relieved. To help prevent serious injury from pressurized fluid, such as skin injection, splashing fluid and moving parts, follow the Pressure Relief Procedure when you stop dispensing and before cleaning, checking, or servicing the equipment.

Relieve pressure at the pump element using two wrenches working in opposite directions on the pump element and pump element fitting to slowly loosen fitting only until fitting is loose and no more lubricant or air is leaking from fitting. Repeat for each pump element installed (FIG. 17).

NOTE: When loosening pump element fitting, do not loosen pump element. Loosening pump element will change the output volume.

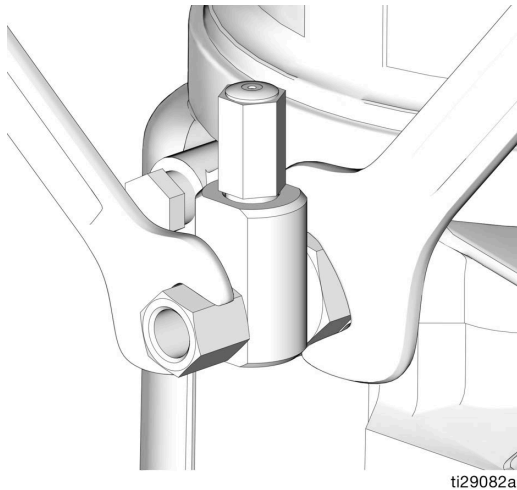
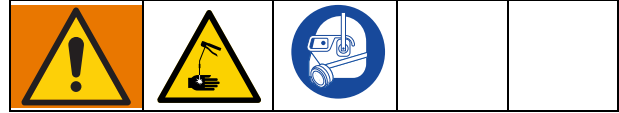

FIG. 17

Connect to Auxiliary Fittings



NOTICE

Do not attach unsupported equipment to auxiliary fittings such as fill ports and pump element. Attaching unsupported equipment to these fitting can result in irreparable housing damage.

- Always use two wrenches working in opposite directions when connecting anything to pump element or auxiliary fittings. See FIG. 17 for an example.
- Torque pump element fittings to 50 in. lbs (5.6 N•m).
- When connecting pump element into housing torque to 50 in. lbs (5.6 N•m).

Pressure Relief Valves



To prevent over-pressurization, which can result in equipment rupture and serious injury, a pressure relief valve appropriate for the lubrication system must be installed close to every pump outlet to alleviate unintended pressure rises in the system and protect the G3 pump from damage.

- Only use a pressure relief valve that is rated for no more than the working pressure of any component installed in the system. See Technical Data, page 33.
- Install a pressure relief valve close to every pump outlet; before any auxiliary fitting.

NOTE: A pressure relief valve can be purchased from Graco. See Parts, page 35.

Set Pump Outlet Volume



NOTE:

- Only use Graco supplied spacers to control output volume.
 - It may be necessary to repeat this outlet volume setup procedure after the pump is operating to re-adjust the volume of dispensed fluids.
1. Follow the **Pressure Relief Procedure**, page 19, before making any adjustments to the pump volume.
 2. Use a wrench to turn the pump element counter-clockwise to loosen. Do not remove the entire pump element. Only back the pump element out enough to allow a spacer to be slid on or off. (FIG. 18).

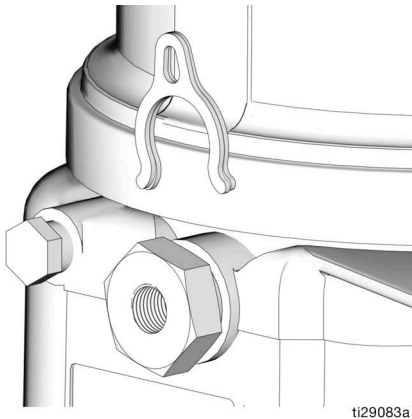

FIG. 18

3. If needed, remove or insert spacers to achieve the required pump output volume. A tool may be needed to facilitate removal.

The pump volume control is set using no spacers, one (1) or two (2) spacers (FIG. 18).

Do not use more than two (2) spacers to adjust the output volume.

No. Spacers	Output Volume / Minute	
	cubic inches	cubic cm
2	0.12	2
1	0.18	3
0	0.25	4

4. Tighten the pump element fitting. Torque fitting to 50 in. lbs. (5.6 N•m).

NOTE:

- The amount of dispensed volume varies depending upon external conditions, such as lubricant temperature and back pressure from downstream connections.
- Use of these volume adjustments in conjunction with setting the ON time of the pump allows for control of the output volume.
- Use these volume adjustments as a starting point and adjust as needed to ensure the desired lubrication dispense.

Fill Reservoir - Grease Dispense Pumps

To ensure optimal performance from the G3 pump:

- Only use NLGI #000 - #2 greases appropriate for the application, automatic dispensing, and the temperature. Consult with the machine and lube manufacturer for details.
- The reservoir can be filled using a hand operated pump, a pneumatic pump, or an electric transfer pump.
- Do not overfill the reservoir.
- Do not operate the G3 pump without a reservoir attached.

NOTICE

- Always clean the fitting (D) (FIG. 19) with a clean dry cloth prior to filling the reservoir. Dirt and/or debris can damage the pump and/or the lubrication system.
- When changing greases, always use compatible fluids or greases.
- Use care when filling the reservoir with a pneumatic or an electric transfer pump, to not pressurize and break the reservoir.

Models Without a Follower Plate

1. Connect the fill hose to the Zerk Inlet Fill Fitting (FIG. 19).

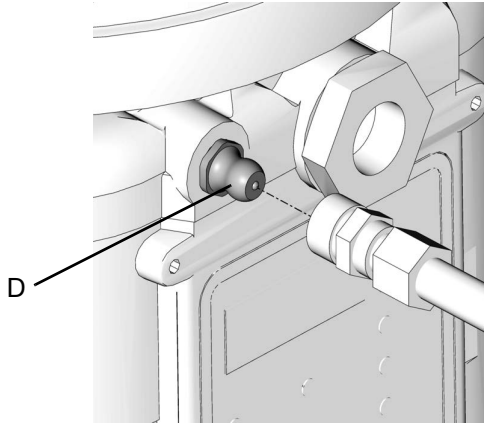

FIG. 19

2. For higher viscosity fluids, start the pump to rotate the stirring paddle during fill to prevent air pockets from forming in the grease. Do not exceed a 30 minute run time.

For models using an external controller, start the pump operation per your controller specifications.

3. Fill the reservoir with NLGI grease.

NOTE: The vent port located in rear of reservoir, should not be used as an overfill port/indicator.

4. Remove the fill hose.

Models With Top Fill

MOVING PARTS HAZARD				
Moving parts can pinch, cut or amputate fingers and other body parts.				
<ul style="list-style-type: none"> • Keep clear of moving parts. • Do not operate equipment with lid removed. • Disconnect power before removing lid. 				

1. Disconnect the power from the equipment.

NOTE: If battery disconnect is not available, remove the power cord (FIG. 20).

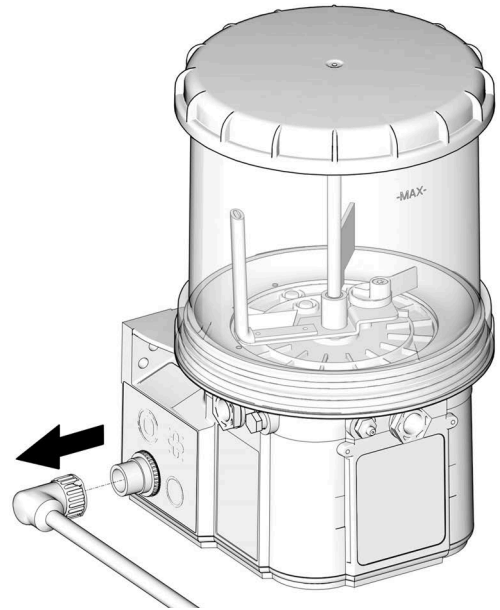

FIG. 20

2. Clean the top of the lid and the area around the top of the reservoir to ensure that no debris falls into the reservoir when the lid is removed.
3. Turn the lid counterclockwise to remove.
4. Place the lid in a clean area to avoid debris getting into the inside of the lid or threads.
5. Fill the reservoir with new clean grease.
6. Make sure that no contaminants enter the reservoir.

NOTICE

Any debris or dirt accidentally introduced into the reservoir should be removed immediately. Do not allow the pump to operate until any debris or dirt are removed.

Operating the pump with debris or dirt in the reservoir, may damage the pump, down stream equipment, and bearings.

7. Clean the threads on the reservoir and the lid.
8. Replace the lid on the reservoir, turning clockwise (approximately 1 3/4 turns).
9. Reconnect the power to the equipment.

Models With a Follower Plate

1. Connect the fill hose to the inlet fitting (FIG. 19).
2. For higher viscosity fluids, start the pump to rotate the stirring paddle during filling to prevent air pockets from forming in the grease. Do not exceed a 30 minute run time.

For models using an external controller, start the pump operation per your controller specifications.

3. Fill the reservoir with grease until the seal of the follower plate breaches the vent hole and the majority of air is expelled from the reservoir.

NOTE: The vent port, located in rear of reservoir, should not be used as an overfill port/indicator.

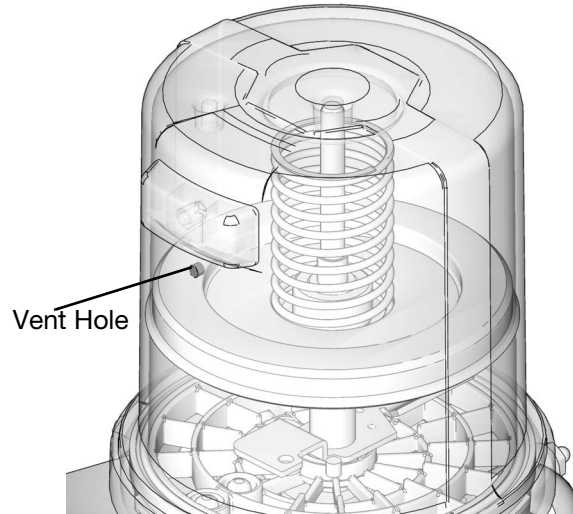

FIG. 21

4. Turn off the air supply (H) to the refill pump (F).
5. Remove the fill hose.

Auto-Fill Shut Off

The Auto-Fill Shut Off is used for refilling the G3 reservoir in an automatic lubrication system. As fluid is added to the reservoir, the plate valve is pushed up to the top of the reservoir, pushing the valve pin and closing the inlet fluid path.

When the fluid refilling path closes, the refilling line pressurizes and brings the refilling pump to a pressurized stall condition.

NOTE: The operator must monitor the system while filling the reservoir to prevent overfilling.

Load Grease

To ensure optimal performance from the G3 pump:

- Only use NLGI #000 - #2 greases appropriate for the application, automatic dispensing, and the temperature. Consult with the machine and lube manufacturer for details.
- Do not overfill the reservoir.
- Do not operate the G3 pump without a reservoir attached.

NOTICE

Use care when filling the reservoir with a pneumatic or an electric transfer pump, to not pressurize and break the reservoir.

Change Grease

When changing greases, always use compatible fluids or greases.



The remote filling station pump stalls (dead-heads) when the reservoir is full, causing the supply system pressure to rise to the maximum output pressure of the filling station pump. To help prevent equipment damage or serious injury caused by pressurized fluid, such as skin injection or injury from splashing fluid, always use a remote filling station pump with a maximum output pressure of 5100 psi (35.1 MPa, 351.6 bar) and use supply hoses with a minimum pressure rating of 5100 psi (35.1 MPa, 351.6 bar).



COMPONENT RUPTURE HAZARD

The maximum working pressure of each component in the system may not be the same. To reduce the risk of over-pressurizing any component in the system, be sure you know the maximum working pressure of each component. Never exceed the maximum working pressure of the lowest rated component in the system. Over-pressurizing any component can result in rupture, fire, explosion, property damage and serious injury.

Regulate input pressure to the remote fill pump so that no fluid line, component or accessory is over pressurized.

Remote Fill With Remote Fill Manifold

The reference letters used in the following instructions refer to FIG. 5, pages 11.

The fill valve is used to relieve pressure in the refill line and to reset the Auto Fill Shut Off. See Fill Valve instruction manual 333393. Graco fill valve, part no. 77X542 is available. Contact your local Graco distributor.

1. Pull out and hold the Pressure Relief Knob (T) long enough to relieve line pressure between Fill Manifold (N) and Auto-Fill Shut Off Valve (B).
2. Verify that the Auto-Fill Shut Off (B) pin is down, indicating it is reset (FIG. 22).

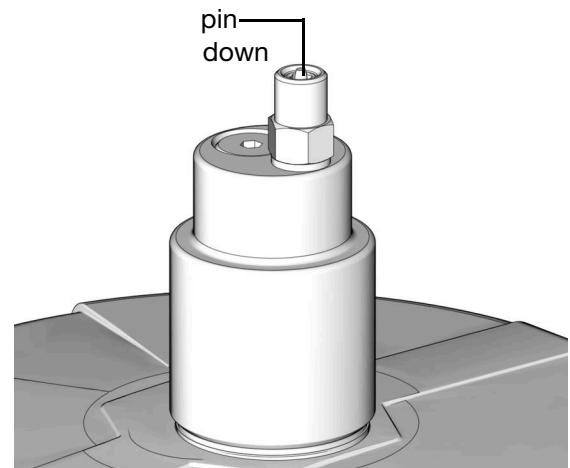

ti28218a

FIG. 22

3. Remove yellow Dust Cover from Fill Coupler (M).
4. Connect the Supply Hose (J) between the Remote Filling Station Pump (F) and the Fill Coupler port marked with an "I".
5. Start the Remote Filling Station Pump (F).
6. When the G3 Reservoir (D) is filled:
 - the Remote Filling Station Pump (F) stalls (dead-heads),
 - the Auto-Fill Shut Off (B) pin pops up as shown in FIG. 23,
 - the Pressure Gauge (R) rises to the fill pump's set pressure.

NOTE: If the pump does not stall (dead-head) there is a leak in the system.

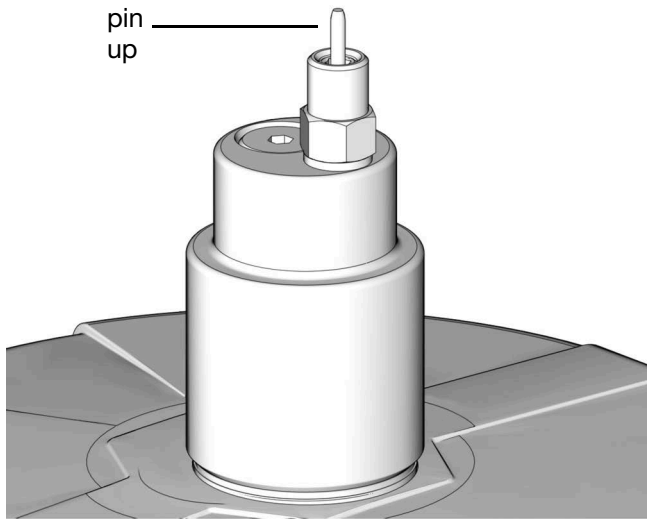

ti28219e

FIG. 23

7. Turn off the Remote Filling Station Pump (F).
8. Pull out and hold the Pressure Relief Knob (T) long enough to relieve line pressure between Fill Manifold (N) and Auto-Fill Shut Off Valve (B) and between Remote Filling Station Pump (F) and Fill Manifold (N).

NOTE: The length of time it takes to vent varies depending on the system design and installation. In some installations it may be necessary to repeat Step 8 to ensure pressure is relieved.

9. Disconnect Supply Hose (J) at Fill Coupler (M).

10. Replace yellow Dust Cover over Fill Coupler (M).

Remote Fill Without Remote Fill Manifold

The reference letters used in the following instructions refer to the FIG. 6, pages 12.

1. A supply hose pressure relief valve (Y) and overflow container (W) (for collecting excess fluid that drains during pressure relief) must be installed in an easily accessible location between the remote filling station pump (F) and the Auto-Fill Shut Off (B). This pressure relief valve is used to relieve pressure in the refill line and to reset the Auto-Fill Shut Off. See Typical Installation, starting on page 11.

A Pressure Relief Kit: 247902 is available from Graco. Contact your distributor or Graco Customer Service for additional information about this kit.

2. Connect Supply Hose (J) at Quick Connect (V).
3. Turn on remote filling station pump (F) and fill the G3 reservoir (D) until the indicator pin on the Auto-Fill Valve pushes up as shown in FIG. 24. The pressure in the refill pump (F) builds and the pump stalls.

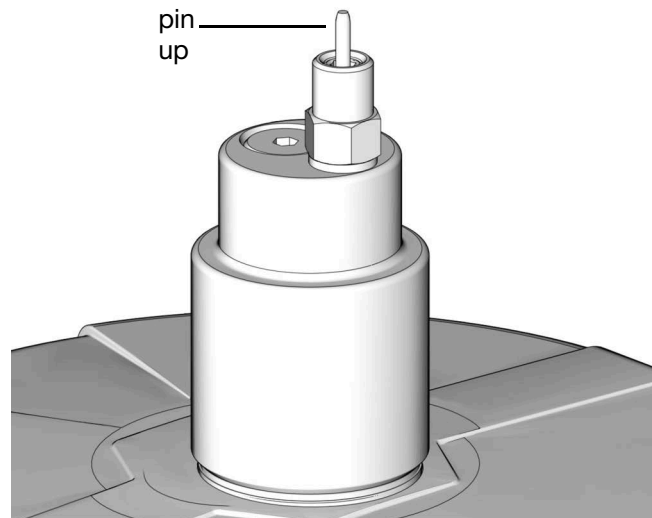

ti28219e

FIG. 24

4. Turn off the air supply (H) to pump (F).
5. Relieve remote filling station pump pressure using the following Remote Filling Station Pressure Relief procedure.

Remote Filling Station Pressure Relief

The reference letters used in the following instructions refer to the FIG. 6, page 12.



The following Pressure Relief Procedure is only used with the Auto-Fill Shut Off Valve to relieve remote filling station and lubricant supply line pressure.

This equipment stays pressurized until pressure is manually relieved. To help prevent serious injury from pressurized fluid, such as skin injection, splashing fluid and moving parts, follow the Pressure Relief Procedure when you stop dispensing and before cleaning, checking, or servicing the equipment.

- a. To relieve pressure between the Refill Pump (F) and Auto-Fill Shut Off (B), open the Supply Hose Pressure Relief Valve (Y) (FIG. 25). Pressure will be released and excess fluid will drain out of the drain tube (L) and into the lubrication overflow container (W).

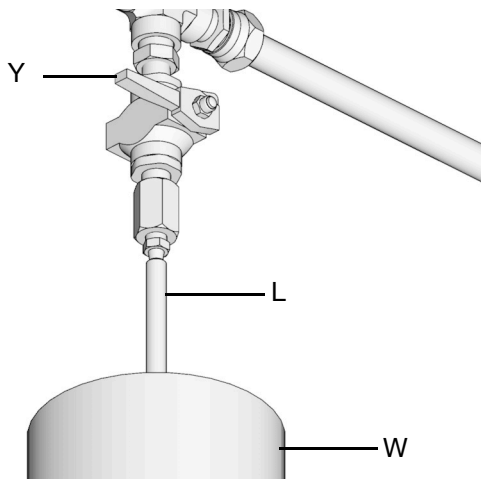

FIG. 25:

- b. Close Supply Hose Pressure Relief Valve (Y) when all pressure has been relieved.
6. Disconnect the supply hose (J) from Quick Connect (V).

Fill Reservoir - Oil Dispense Pumps

- Only use oil appropriate for the application, automatic dispensing, and the equipment's operating temperature. Consult with machine and lube manufacturer for details.
- The reservoir can be filled using a hand operated pump, pneumatic pump or electric transfer pump.
- Do not overfill (FIG. 26).
- Do not operate G3 without reservoir attached.
- Only use oils with viscosity at least 40 cSt.

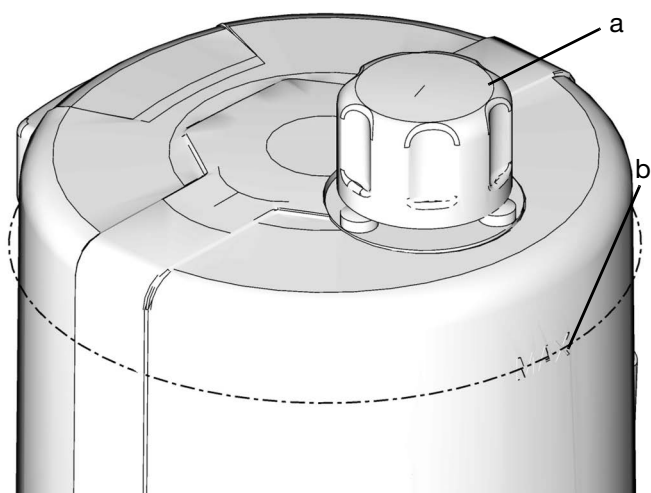

FIG. 26

1. Remove fill cap (a).
2. Pour oil into reservoir to max fill line (b).
3. Replace fill cap. Hand tighten cap, securely.

Prime the Pump

NOTE: It is not necessary to prime pump every time the pump is filled with lubricant.

The pump only requires priming the first time it is used, or if it is allowed to run dry.

1. Loosen pump element fitting (FIG. 27).

NOTE: When loosening pump element fitting, do not loosen pump element. Loosening pump element will change the output volume.

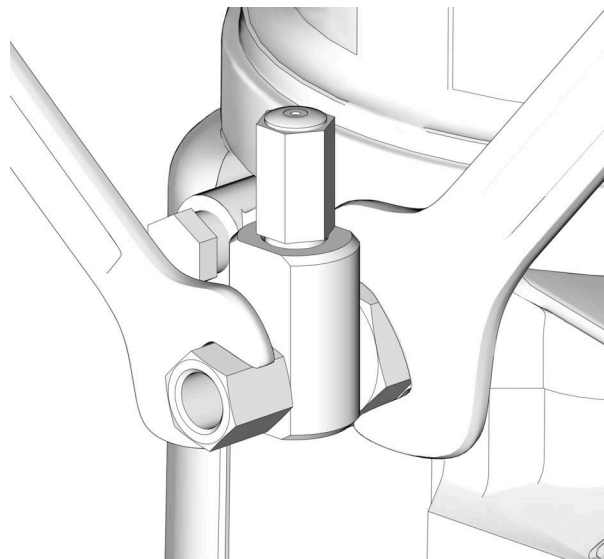

ti29082a

FIG. 27

2. Only run pump until air-free lubricant is dispensed out of element fitting (FIG. 28).

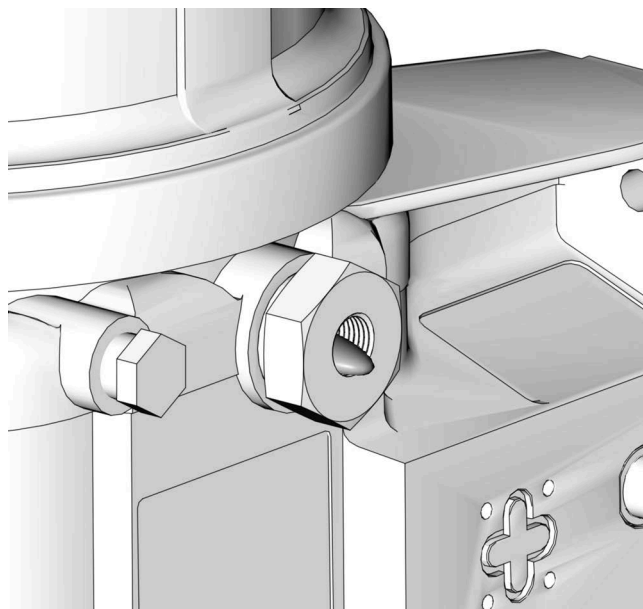

ti29084a

FIG. 28

3. Tighten pump element fitting using two wrenches working in opposite directions (FIG. 27).

Pump Operation

The G3 Pump can be controlled using an external, user supplied, power source and controller.

Refer to **System Configuration and Wiring**, page 13 for required fusing and wiring information.

NOTE:

- When using an external power source and controller, Pump ON (Run) Time should be set for no longer than 30 minutes.
- In most cases, Pump OFF (Rest) Time should be twice as long as Pump ON (Run) time. If alternative ON / OFF times are required, contact Graco Customer Service for assistance.

Low Level Output Option

Some G3 pumps without controllers include a Low Level Output Option. It can be configured with an M12 connector in code location h or with a DIN connector in code location m. (See **Understanding the Model Number**, page 5.) The low level signal is monitored across PINS 3 and 4. For PIN 3 and 4 locations and wiring information the Low Level Outputs diagram, page 16.

NOTE: A low level warning is triggered when the controller detects PINS 3 and 4 have momentarily closed.

Grease Pumps

When the grease level has reached a low warning level, PINS 3 and 4 momentarily close (1 time per paddle revolution) sending the signal that the fluid has reached a low level to the controller.

To ensure that a low level condition has been met, 3 or more low level triggers must be detected within 1 minute or less.

See FIG. 29 for an illustration of a typical Low Level Output response to low grease level.

Typical Low Level Output Response with Low Level Fluid in Grease Models

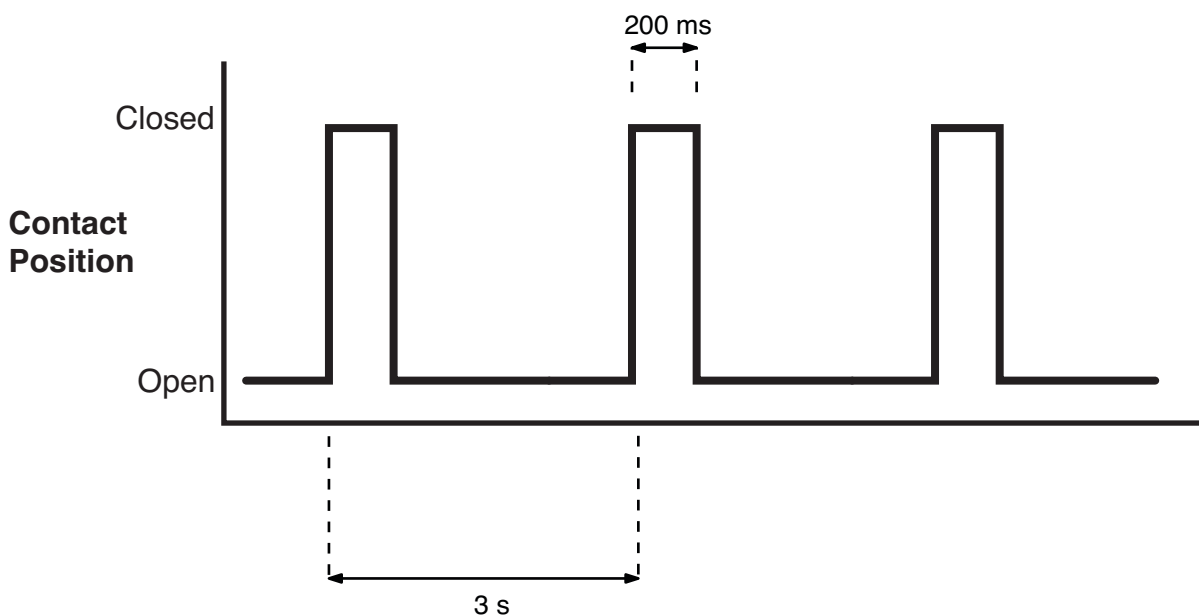

FIG. 29

Oil Pumps

When the oil level has reached a low warning level, PINS 3 and 4 close, sending the signal to the controller that the fluid has reached a low level.

To ensure that a low level condition has been met, the low level trigger must be detected for 10 continuous seconds.

See FIG. 30 for an illustration of a typical Low Level Output response to low oil level.

Typical Low Level Output Response with Low Level Fluid in Oil Models

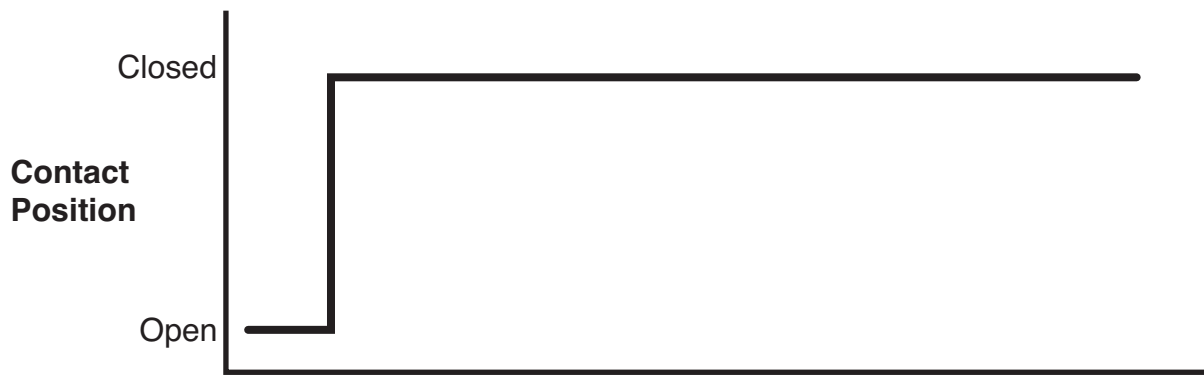

FIG. 30

Recycling and Disposal

End of Product Life

At the end of the product's useful life, dismantle and recycle it in a responsible manner.

- Perform the **Pressure Relief Procedure**, page 19.
- Drain and dispose of fluids according to applicable regulations. Refer to the material manufacturer's Safety Data Sheet.
- Remove motors, batteries, circuit boards, LCDs (liquid crystal displays), and other electronic components. Recycle according to applicable regulations.

Do not dispose of batteries or electronic components with household or commercial waste.



Deliver remaining product to a recycling facility.

Troubleshooting

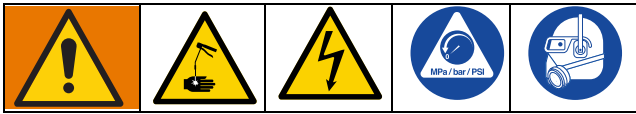

Problem	Cause	Solution
Unit does not power on	Incorrect/loose wiring	Refer to Installation instructions, page 9.
Unit does not power on (DC models only)	Tripped external fuse due to internal component failure	Contact Graco Customer Service.
	Tripped external fuse due to pumping non-cold weather lubricant in cold weather -13°F (-25°C)	Replace lubricant with pumpable lubricant, rated for environmental conditions and application. Replace fuse.
Unit does not power on (AC models only)	Tripped internal power supply fuse due to power supply failure	Contact Graco Customer Service.
Lubricant leaks past seal located on the bottom of the reservoir	Reservoir retaining tabs are cracked or broken	Replace reservoir.
	Reservoir is being pressurized during filling	Ensure vent hole is not plugged. If problem persists, contact Graco Customer Service or your local Graco distributor for assistance.
Unit not pumping during ON cycle, but external controller functions	Failed motor	Replace unit.
Follower plate is not going down	Air is trapped in the reservoir between the follower plate and lubricant	Add grease following Fill Reservoir - Grease Dispense Pumps instructions, page 20. Ensure air is purged.
Pump takes several minutes before it begins pumping at the highest pump volume setting (no stroke adjust spacers installed)	Pumping non-cold weather lubricant in cold weather -13°F (-25°C)	Add 1 stroke adjust spacer and adjust lube cycle time to accommodate the difference in pump volume per stroke.
In an Injector System without sensor feedback, unit does not vent properly	Vent valve time needs to be configured	Adjust external vent valve control time.
After wiring and installing equipment, pump is not working (DC models only)	Pump wired backwards	Rewire pump. See Wire and Installation Diagrams , page 14

Maintenance

Frequency	Component	Required Maintenance
Daily and at refill	Fill Fittings	Keep all fittings clean using a clean dry cloth. Dirt and/or debris can damage pump and/or lubrication system.
Daily	G3 Pump Unit and Reservoir	Keep pump unit and reservoir clean using a clean dry cloth.
Monthly	External Wiring Harness	Verify external harnesses are secure.

Parts - 2 Liter Models

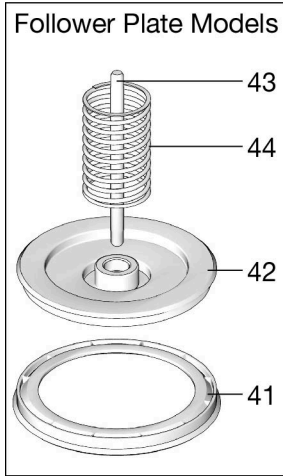

Oil Reservoir

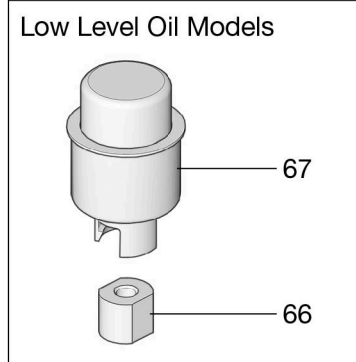
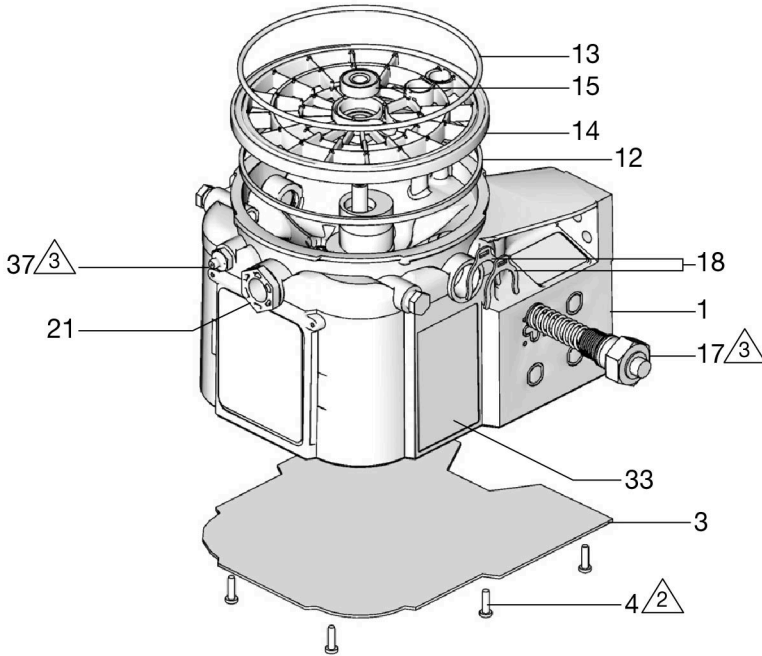
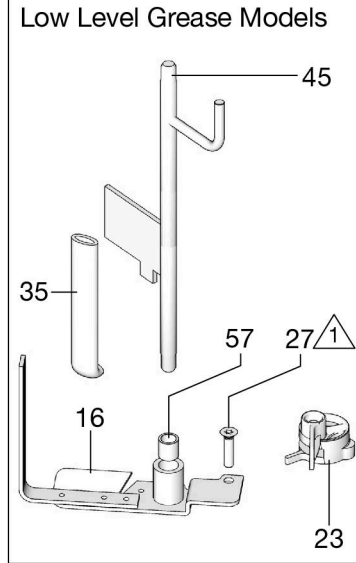
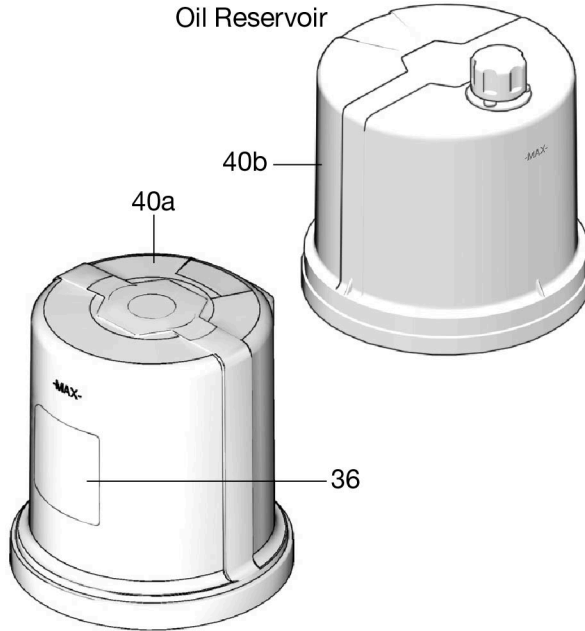

- △1 Torque to 14 in-lb (1.58 N•m)
- △2 Torque to 30 in-lb (3.4 N•m)
- △3 Torque to 50 in-lb (5.6 N•m)

ti42063b

Parts - 4 Liter and Larger Models

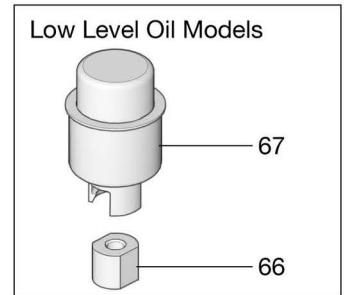
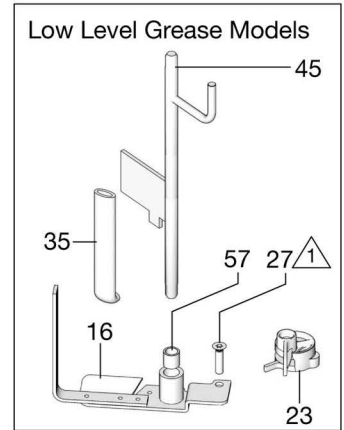
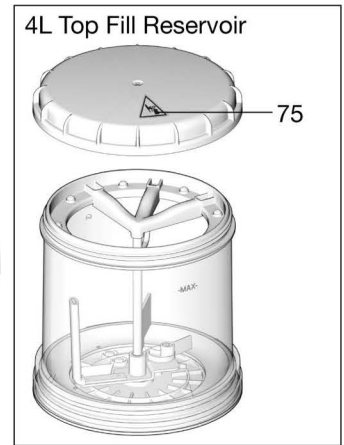
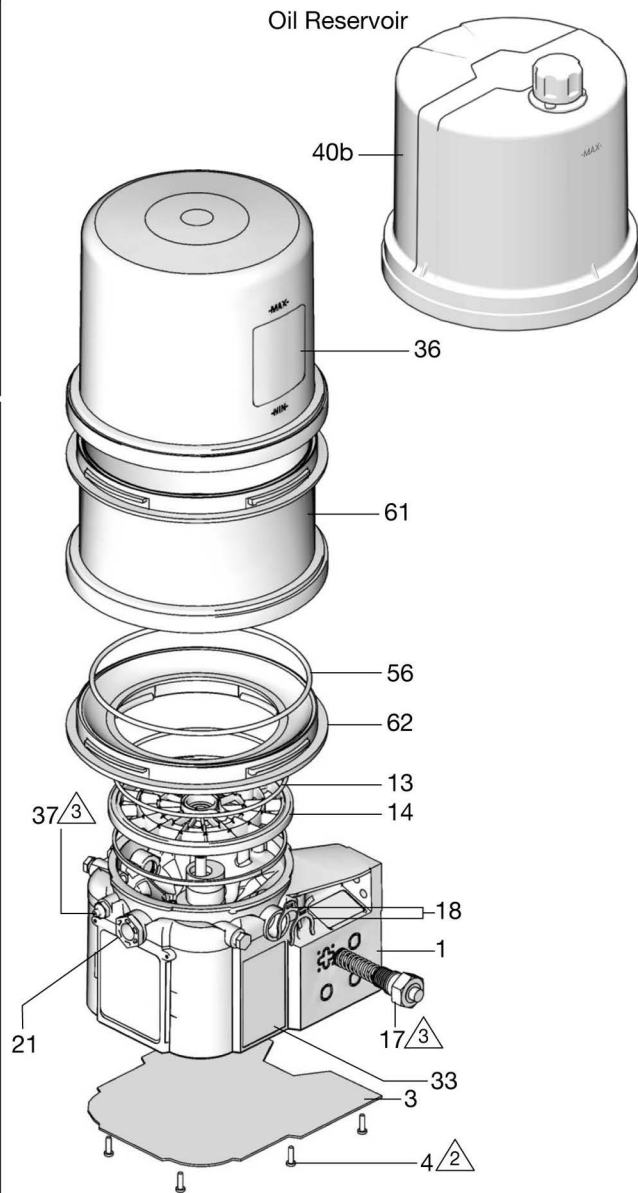
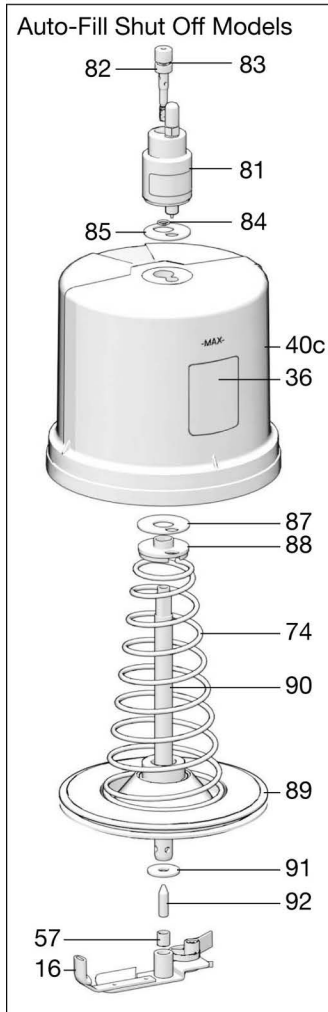
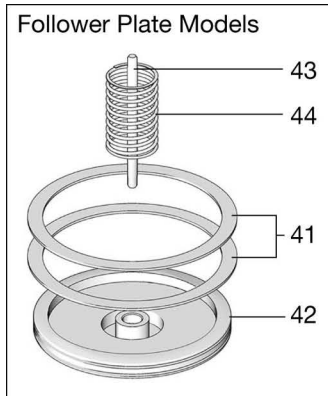

- △1 Torque to 14 in-lb (1.58 N•m)
- △2 Torque to 30 in-lb (3.4 N•m)
- △3 Torque to 50 in-lb (5.6 N•m)

ti42064b

Parts

Ref	Part	Description	Qty
1		BASE, three pump housing	1
3	25V211	COVER, bottom, with seal	1
4	133767	SCREW, mach, torx pan hd, o-ring	9
12	127079	RECT-RING, included in kit 571042, 571069, 571179	1
13	132524	O-RING, included in Kit 571042, 571044, 571045, 571069, 571179	1
14	278144	PLATE, ricer	1
15	120822	BEARING, ball	1
16		PADDLE, stirring, 2 L models without follower plate, included in Kit 571044,	1
		PADDLE, stirring, 4 L or larger models without follower plate, included in kit 571046	1
		PADDLE, stirring, 2 L models with follower plate, included in Kit 571045	1
		PADDLE, stirring, 4 L and larger models with follower plate, included in Kit 571047	1
17		PUMP, element, included in Kit 571041	1
18	16F368	SPACER, stroke adjust, included in Kit 571041	2
21	278296	PLUG, pump, 3/4-16	2
23❖	279043	PADDLE, low level	1
27	123025	SCREW, M6	1
33▲	16A579	LABEL, safety	1
35		WIPER, stirring, included in Kits 571044, 571045, 571046, and 571047	1
36		LABEL, brand	1
37	123741	FITTING, zerk, grease, not included on oil models	1
40a	24E984	RESERVOIR, 2 L, grease, included in Kit 571042, 571069	1
40b	16G021	RESERVOIR, 2 L, oil, included in Kit 571179	1
40a	577005	RESERVOIR, 4 L, grease, included in Kit 571183	1

Ref	Part	Description	Qty
40b	16G020	RESERVOIR, 4 L, oil, included in kit 571182	1
40c	17F484	RESERVOIR, 4 L, G3 AFSO	1
41	278139	SEAL, follower plate, 2 L models	1
	16V763	SEAL, follower plate, 4 L models	2
42		PLATE, follower	1
43		ROD, follower plate	1
44		SPRING, compression	1
45†	24D838	BAFFLE, low level, 2 L	1
	24E246	BAFFLE, low level, 4 L	1
	24F836	BAFFLE, low level, 8 L	1
	24F923	BAFFLE, low level, 12 L	1
	24F924	BAFFLE, low level, 16 L	1
	24F836	BAFFLE, low level, 8 L AFSO	1
56	127144	SEAL, oval	1
57	117156	BEARING, sleeve	1
58▲	196548	LABEL, electric shock (not shown)	1
61	25C764	RESERVOIR, mid-section kit, with o-ring (see quantity by size / model below)	
		8 L models	1
		12 L models	2
		16 L models	3
62	574002	ADAPTER, reservoir, 4 L models and larger	1
66		NUT, oil	1
67	24N806	FLOAT, oil models	1
74		SPRING, plate, valve, reset	1
75▲	15H108	LABEL, safety, pinch	1
81		VALVE, AFSO	1
82		BOLT, mounting	1

Ref	Part	Description	Qty
83		PACKING, o-ring	1
84		PACKING, o-ring	1
85		SEAL, upper, reservoir	1
87		SEAL, lower, reservoir	1
88		SPACER, seal, base	1
89		PLATE, valve	1
90		TUBE, center fill	1
91		WASHER, plain	1
92		PIN, alignment	1
200	127783	CABLE, CPC, 15 ft (4.5 m), SOOW w/7pos, 2 pin, 90 deg (See Wiring Diagram, page 15)	1
	16U790	CABLE, DIN, to flying leads (See Wiring Diagram, page 14)	1
	2003467	CABLE, CPC, 15 ft (4.5 m), 7pos, 5 pin, 90 deg (See Wiring Diagram, page 15)	1
	2003896	CABLE, CPC, 30 ft (9.0 m), 7pos, 5 pin, 90 deg (See Wiring Diagram, page 15)	1
201	124300	CABLE, M12, 16.5 ft (5m), 4 wire, straight male to flying leads (See Wire and Installation Diagrams , page 14)	1
	124333	CABLE, M12, 16.5 ft (5m), 4 wire, straight male to female (See Wire and Installation Diagrams , page 14)	1
202	124301	CONNECTOR, straight, M12 female, 4 Pin	1
	124594	CONNECTOR, straight, M12 female (see Wire and Installation Diagrams , page 14)	1
	124595	CONNECTOR, straight, M12 male, (see Wire and Installation Diagrams , page 14)	1

▲ Replacement safety labels, tags, and cards are available at no cost.

❖ Also order Ref 27, Part No. 123025

† Also order Ref. 57, Part No. 117156 when ordering this part.

Pressure Relief Valves

Important Information regarding Pressure Relief Valve 16C807.

◆ **Pressure Relief Valve 16C807 can only be used on the G3, G1, or G-Mini Pumps.** It is not intended for use with any other products.

The pressure relief valve uses a pressure adjustment screw (a) to set the pressure release point. **It is not intended as a way to relieve pressure during normal operation**, but as a protective measure in the event there is an unintended pressure increase in the system. Do not use this pressure relief valve as a means of relieving pressure in day-to-day, normal cycle operation.

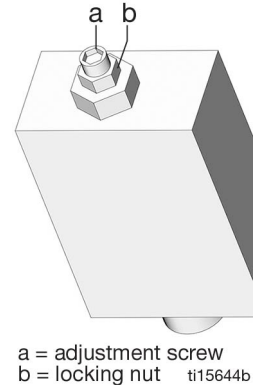

The pressure adjustment screw may require periodic adjustments. Whenever the valve is set/adjusted (after the set point is found) it is important to ensure that the valve is not bottomed out and there is at least 1/2 turn of adjustment remaining. This is determined by turning the screw (a) 1/2 turn and then back turning it out again.

NOTE: Turning adjustment screw (a) clockwise increases pressure.

NOTE: Each pressure relief valve requires banjo kit p/n 571058. (Except 16C807 because the banjo is already included in Kit 571028.)

Part	Description	Qty
16C807◆	VALVE, pressure relief, 500-3500 psi (3.44 MPa, 34.4 bar - 24.1 MPa, 241 bar), Set pressure 3000 psi \pm 10% (20.68 MPa, 206.8 bar \pm 10%) Included in Kit 571028	1
563156	VALVE, pressure relief, 750 psi (5.17 MPa, 51.71 bar)	1
563157	VALVE, pressure relief, 1000 psi (6.89 MPa, 68.95 bar)	1
563158	VALVE, pressure relief, 1500 psi (10.34 MPa, 103.42 bar)	1
563159	VALVE, pressure relief, 2000 psi (13.78 MPa, 137.89 bar)	1
563160	VALVE, pressure relief, 2500 psi (17.23 MPa, 172.36 bar)	1
563161	VALVE, pressure relief, 3000 psi (20.68 MPa, 206.84 bar)	1

Installation and Repair Kits

Kit No.	Description	Manual Number
571026	KIT, output union, 3 pump	3A0523
571063	KIT, output union, 2 pump	
571028	KIT, return to reservoir NPT, includes pressure relief valve 16C807	3A0525
571071	KIT, return to reservoir BSPP, includes pressure relief valve 16C807	
24M478	KIT, vent valve, 12 volt DC, NO, NPT DEU	3A0526
24M479	KIT, vent valve, 24 volt DC, NO, NPT DEU	
24M480	KIT, vent valve, 115 VAC, NO, NPT, DIN	
24N182	KIT, vent valve, 230 VAC	
571036	KIT, cover with G label	
571041	KIT, pump element, includes Ref 17, 18, 33	3A0533
571042	KIT, repair, 2 L reservoir, includes Ref 13, 36, 40	3A0534
571069	KIT, repair, 2 L reservoir, for models with follower plate, includes Ref 13, 36, 40	
571044	KIT, replacement, paddle, 2 L, for models without follower plate, includes Ref 13, 16, 35, 57	3A0535
571045	KIT, replacement, paddle, 2 L, for models with follower plate, includes Ref 13, 16, 35, 40a, 42, 57	
571046	KIT, replacement, paddle, 4-16 L, for models without follower plate, includes Ref 13, 16, 35, 57	
571047	KIT, replacement, paddle, 4 L, for models with follower plate, includes Ref 13, 16, 35, 57	
571058	KIT, output adapter, NPT	3A0522
571070	KIT, output, adapter, BSPP	
571060	KIT, fill, zerk, leakproof	NA
571179	KIT, repair, reservoir oil, 2 L models, includes Ref 13, 36, 40b	3A0534
571182	KIT, repair, reservoir, oil 4 L models, includes Ref 13, 36, 40b	
571183	KIT, repair, reservoir, grease, 4 L models, includes Ref 13, 36, 40b	
127685	RING, fixing, for CPC connector	NA
16G022	FILLER CAP	NA

Reservoir Conversion Kits

Kit No.	Description	Manual Number
571155	KIT, reservoir conversion, 4 L	3A1260
571156	KIT, reservoir conversion, 8 L	
571157	KIT, reservoir conversion, 12 L	
571158	KIT, reservoir conversion, 16 L	3A8295
571299	KIT, reservoir conversion, 4 L Top Fill	
571286	KIT, reservoir conversion, 4 L	3A5051
571287	KIT, reservoir conversion, 8 L	
571288	KIT, reservoir conversion, 12 L	
571289	KIT, reservoir conversion, 16 L	

Fuses

Part	Description	Qty
571039	FUSE, 7.5A for 12 volt DC	1
571040	FUSE, 4A for 24 volt DC	1

Dimensions

Model	Height		Width		Depth	
	Inches	cm	Inches	cm	Inches	cm
2 L	13.25	33.65	8.00	20.32	9.00	22.86
4 L	14.50	36.83	9.25	23.50	10.00	25.40
4 L Top Fill	15.50	39.38	9.25	23.50	10.00	25.40
8 L	18.50	47.00	9.25	23.50	10.00	25.40
8 L Top Fill	19.50	49.53	9.25	23.50	10.00	25.40
12 L	23.00	58.42	9.25	23.50	10.00	25.40
12 L Top Fill	24.00	60.96	9.25	23.50	10.00	25.40
16 L	27.50	69.85	9.25	23.50	10.00	25.40
16 L Top Fill	28.50	72.39	9.25	23.50	10.00	25.40

Mounting Pattern

(For correct mounting configuration, choose either Option 1 or Option 2). See P/N 126916 template.

Option 1

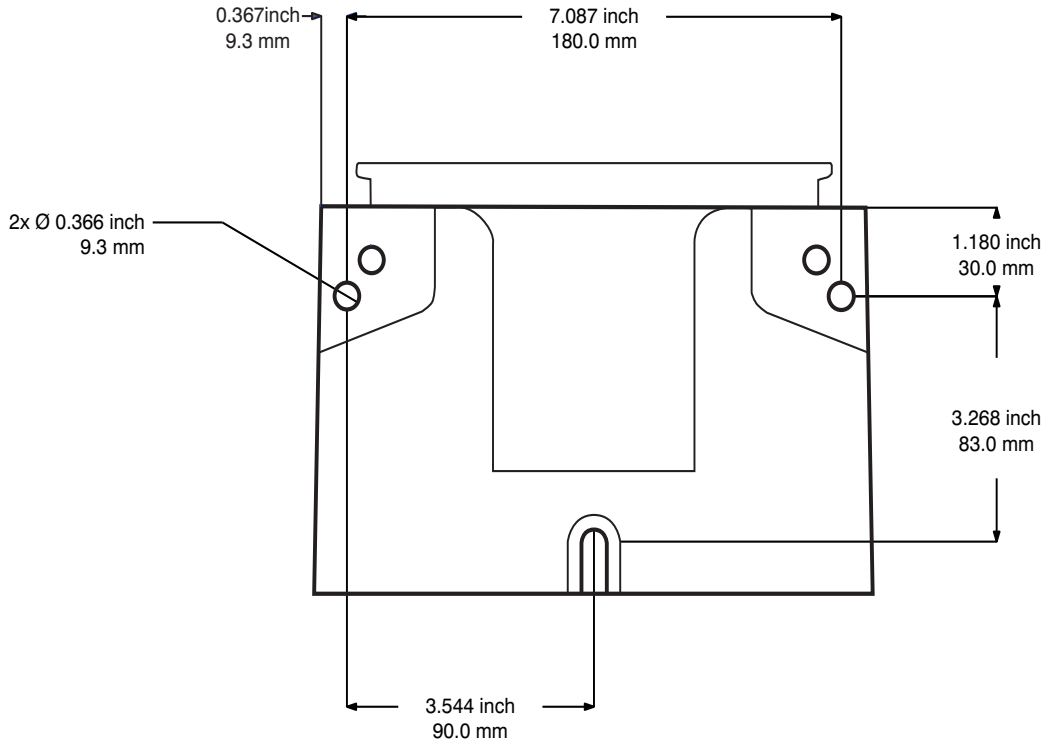

Option 2

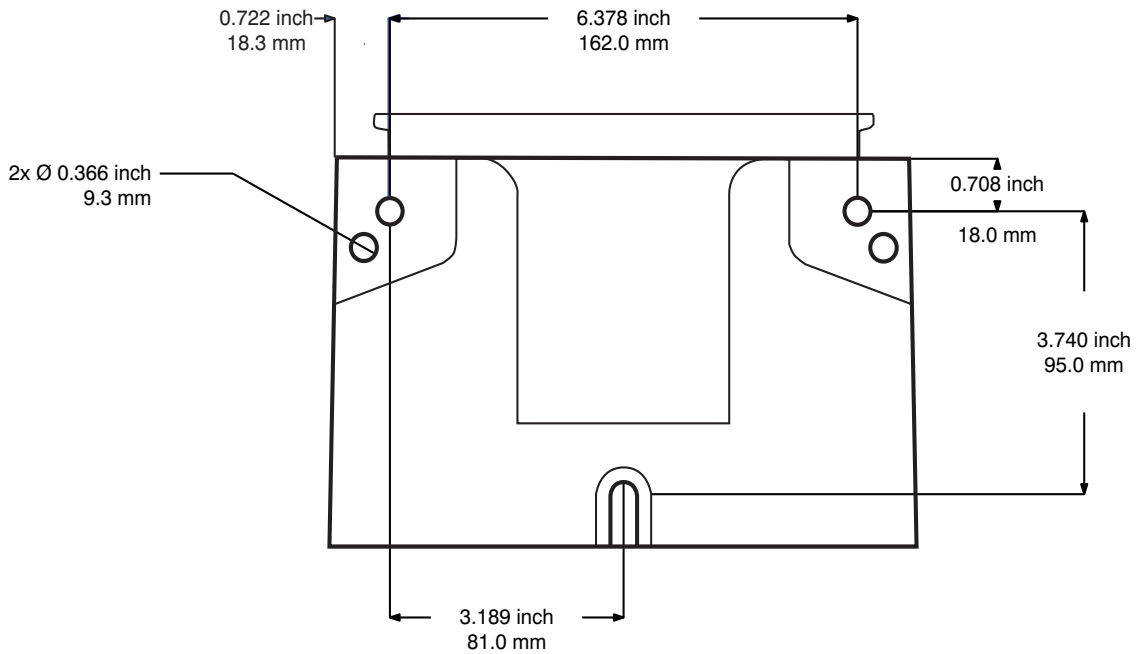

FIG. 31

Technical Specifications

G3 Standard Automatic Lubrication Pump		
	US	Metric
Pump output pressure	5100 psi	35.1 MPa, 351.6 bar
Auto-Fill Shut Off maximum inlet pressure	5000 psi	34.4 MPa, 344.7 bar
Power		
100 - 240 VAC	100 - 240 VAC, 0.8A current, 90 VA Power, 47/63 Hz, Single phase, inrush/locked rotor, max 40A (1 ms)	
12 VDC	9 - 16 VDC; 5A current, 60 W, inrush/locked rotor 12 A	
24 VDC	18 - 30 VDC; 2.5 A current, 60 W, inrush/locked rotor 6 A	
Outputs - Low Level (Dry Contact)		
Contact rating	10 W Maximum	
Switch rating	30 VDC Maximum	
Switching current	0.5 A Maximum	
Carry current	1.2 A Maximum	
Fluid		
Grease Models	Grease NLGI #000 - #2	
Oil Models	At least 40 cSt oil	
Pumps	Up to 3	
Pump Outlet	1/4-18 NPSF, Mates with 1/4-18 NPT male fittings	
Reservoir Size	2, 4, 8, 12, 16 L	
IP Rating	IP69K	
Ambient Temps	-40°F - 158°F	-40°C - 70°C
Noise (dBa)		
Maximum sound pressure	<70dBa	
Materials of Construction		
Wetted Parts	nylon 6/6 (PA), amorphous polyamide, T5004-060, zinc plated steel, carbon steel, alloy steel, stainless steel, nitrile rubber (buna-N), bronze, nickel plated alnico, chemically lubricated acetal, aluminum, PTFE	
All trademarks or registered trademarks are the property of their respective owners.		

Pump Maximum Weight lb (kg)			
Model	With follower plate	Without follower plate	With auto-fill shut off
2 L	12.4 (5.6)	11.4 (5.2)	N/A
4 L	15.3 (6.9)	13.1 (5.9)	17.9 (8.1)
8 L	16.8 (7.6)	14.6 (6.6)	19.7 (8.9)
12 L	18.4 (8.3)	16.1 (7.3)	21.6 (9.8)
16 L	19.9 (9.0)	17.6 (8.0)	23.4 (10.6)

California Proposition 65

CALIFORNIA RESIDENTS

 **WARNING:** Cancer and reproductive harm – www.P65warnings.ca.gov.

Graco Standard Warranty

Graco warrants all equipment referenced in this document which is manufactured by Graco and bearing its name to be free from defects in material and workmanship on the date of sale to the original purchaser for use. With the exception of any special, extended, or limited warranty published by Graco, Graco will, for a period of twelve months from the date of sale, repair or replace any part of the equipment determined by Graco to be defective. This warranty applies only when the equipment is installed, operated and maintained in accordance with Graco's written recommendations.

This warranty does not cover, and Graco shall not be liable for general wear and tear, or any malfunction, damage or wear caused by faulty installation, misapplication, abrasion, corrosion, inadequate or improper maintenance, negligence, accident, tampering, or substitution of non-Graco component parts. Nor shall Graco be liable for malfunction, damage or wear caused by the incompatibility of Graco equipment with structures, accessories, equipment or materials not supplied by Graco, or the improper design, manufacture, installation, operation or maintenance of structures, accessories, equipment or materials not supplied by Graco.

This warranty is conditioned upon the prepaid return of the equipment claimed to be defective to an authorized Graco distributor for verification of the claimed defect. If the claimed defect is verified, Graco will repair or replace free of charge any defective parts. The equipment will be returned to the original purchaser transportation prepaid. If inspection of the equipment does not disclose any defect in material or workmanship, repairs will be made at a reasonable charge, which charges may include the costs of parts, labor, and transportation.

THIS WARRANTY IS EXCLUSIVE, AND IS IN LIEU OF ANY OTHER WARRANTIES, EXPRESS OR IMPLIED, INCLUDING BUT NOT LIMITED TO WARRANTY OF MERCHANTABILITY OR WARRANTY OF FITNESS FOR A PARTICULAR PURPOSE.

Graco's sole obligation and buyer's sole remedy for any breach of warranty shall be as set forth above. The buyer agrees that no other remedy (including, but not limited to, incidental or consequential damages for lost profits, lost sales, injury to person or property, or any other incidental or consequential loss) shall be available. Any action for breach of warranty must be brought within two (2) years of the date of sale.

GRACO MAKES NO WARRANTY, AND DISCLAIMS ALL IMPLIED WARRANTIES OF MERCHANTABILITY AND FITNESS FOR A PARTICULAR PURPOSE, IN CONNECTION WITH ACCESSORIES, EQUIPMENT, MATERIALS OR COMPONENTS SOLD BUT NOT MANUFACTURED BY GRACO. These items sold, but not manufactured by Graco (such as electric motors, switches, hose, etc.), are subject to the warranty, if any, of their manufacturer. Graco will provide purchaser with reasonable assistance in making any claim for breach of these warranties.

In no event will Graco be liable for indirect, incidental, special or consequential damages resulting from Graco supplying equipment hereunder, or the furnishing, performance, or use of any products or other goods sold hereto, whether due to a breach of contract, breach of warranty, the negligence of Graco, or otherwise.

FOR GRACO CANADA CUSTOMERS

The Parties acknowledge that they have required that the present document, as well as all documents, notices and legal proceedings entered into, given or instituted pursuant hereto or relating directly or indirectly hereto, be drawn up in English. Les parties reconnaissent avoir convenu que la rédaction du présente document sera en Anglais, ainsi que tous documents, avis et procédures judiciaires exécutés, donnés ou intentés, à la suite de ou en rapport, directement ou indirectement, avec les procédures concernées.

Graco Information

For the latest information about Graco products, visit www.graco.com.

For patent information, see www.graco.com/patents.

TO PLACE AN ORDER, contact your Graco distributor or call to identify the nearest distributor.

Phone: 612-623-6928 **or Toll Free:** 1-800-533-9655, **Fax:** 612-378-3590

All written and visual data contained in this document reflects the latest product information available at the time of publication. Graco reserves the right to make changes at any time without notice.

Original instructions. This manual contains English. MM 332291

Graco Headquarters: Minneapolis

International Offices: Belgium, China, Japan, Korea

GRACO INC. AND SUBSIDIARIES • P.O. BOX 1441 • MINNEAPOLIS MN 55440-1441 • USA
Copyright 2013, Graco Inc. All Graco manufacturing locations are registered to ISO 9001.

www.graco.com
Revision V, May 2024