

Merkur™ Electrostatic Spray Packages

312798V

EN

*For electrostatic finishing and coating applications in hazardous or non-hazardous locations, including applications that require heated material, and applications that use isocyanates, UV coatings, and other moisture-sensitive materials.
For professional use only.*



Important Safety Instructions

Read all warnings and instructions in this manual.
Save these instructions.

See pages 8 to 13 for model information, including maximum working pressure and approvals.

**Model G30W86
shown**

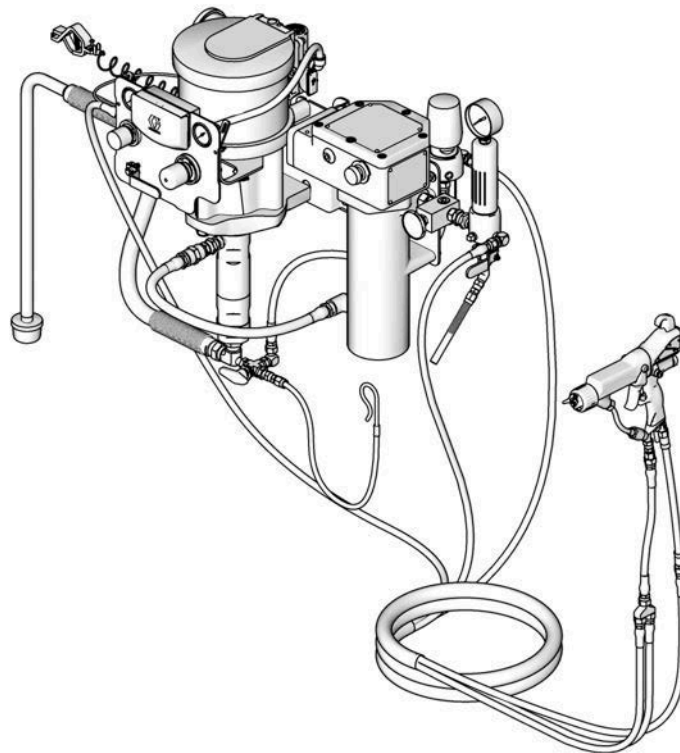

ti13209c

Contents

Related Manuals	3
Warnings	4
Important Two-Component Material Information .	7
Isocyanate Conditions	7
Material Self-ignition	7
Keep Components A and B Separate	7
Moisture Sensitivity of Isocyanates	7
Changing Materials	7
Models	8
Agency Approvals	9
Merkur 15:1 Packages, Ambient (G15Wxx and G15Cxx)	9
Merkur Bellows 15:1 Packages, Ambient (G15Bxx) 10	
Merkur 18:1 Packages, Ambient(G18Wxx and G18Cxx)	10
Merkur 18:1 Packages, Heated (G18Wxx)	10
Merkur 23:1 Packages, Ambient (G23Wxx and G23Cxx)	11
Merkur Bellows 23:1 Packages, Ambient(G23Bxx) 11	
Merkur 24:1 Packages, Ambient (G24Wxx and G24Cxx)	11
Merkur Bellows 24:1 Packages, Ambient (G24Bxx) 12	
Merkur 28:1 Packages, Ambient (G28Wxx and G28Cxx)	12
Merkur 28:1 Packages, Heated (G28Wxx and G28Cxx)	12
Merkur 30:1 Packages, Ambient (G30Wxx and G30Cxx)	13
Merkur 30:1 Packages, Heated (G30Wxx and G30Cxx)	13
Merkur Bellows 35:1 Packages, Ambient (G35Bxx) 13	
Installation	14
General Information	16
Prepare the Operator	16
Prepare the Site	16
Mount the Pump	16
Ventilate the Spray Booth	17
Components	17
Grounding	18
Setup	19





Operation	21
Pressure Relief Procedure	21
Flush Before Using Equipment	21
Trigger Lock	21
Wet Cup	22
Prime the Pump	22
Install the Spray Tip	23
Adjust the Atomization	23
Adjust the Spray Pattern	24
Shutdown	24
Maintenance	25
Preventive Maintenance Schedule	25
Tighten Threaded Connections	25
Flush the Pump	25
Wet Cup	25
Troubleshooting	26
DataTrak Controls and Indicators	27
DataTrak Operation	28
Setup Mode	28
Run Mode	28
Replace DataTrak Battery or Fuse	31
Parts	33
Ambient Models, Cart Mount or Wall Mount ...	33
Bellows, Cart Mount	34
Heated Models, Cart Mount or Wall Mount	36
Heated Models (Continued)	38
Kits	39
Wall Mount Kit 24A578 (non-Bellows)	39
Cart Mount Kit 256427 (non-Bellows)	39
Bellows Cart Mount Kit 24E879	40
Bellows Air Control Mounting Kit	40
Pump and Gun Control Panel Kits	41
Air Controls Mounting Kit (non-Bellows)	42
5-Gallon Suction Hose Kits	42
55-Gallon Suction Hose Kits	42
PTFE Suction Hose Kits	42
DataTrak	42
Drain Valve Kit 256425	42
Overflow Chamber Kit 24E298	42
Mounting Dimensions	43
Wall Bracket (Non-Bellows)	43
Technical Data	44
Package Weights	45
Ambient	45
Heated	45
Graco Standard Warranty	46
Graco Information	46

Related Manuals

Manual	Description
312792	Merkur Displacement Pump
312793	Merkur Bellows Displacement Pump
312794	Merkur Pump Assembly
312795	Merkur Bellows Pump Assembly
312796	NXT™ Air Motor
312797	Merkur Non-Heated Spray Packages
312799	Merkur Bellows Non-Heated Spray Packages
313255	Merkur Heated Spray Packages
3A2495	Pro Xp AA Spray Gun
307273	Fluid Outlet Filter
309524	Viscon HP Heater
306860	Back Pressure Regulator
313541	DataTrak Kits

Warnings

The following warnings are for the setup, use, grounding, maintenance, and repair of this equipment. The exclamation point symbol alerts you to a general warning and the hazard symbols refer to procedure-specific risks. When these symbols appear in the body of this manual, refer back to these Warnings. Product-specific hazard symbols and warnings not covered in this section may appear throughout the body of this manual where applicable.

 WARNING	
	<p>FIRE AND EXPLOSION HAZARD</p> <p>Flammable fumes, such as solvent and paint fumes, in work area can ignite or explode. To help prevent fire and explosion:</p> <ul style="list-style-type: none"> • Ground equipment, personnel, object being sprayed, and conductive objects in work area. See Grounding instructions. • Only use grounded Graco conductive air supply hoses. • Use and clean equipment only in well ventilated area. • Use cleaning solvents with highest possible flash point when flushing or cleaning equipment. • Always turn the electrostatics off when flushing, cleaning or servicing equipment. • If there is static sparking or you feel a shock, stop operation immediately. Do not use equipment until you identify and correct the problem. • Eliminate all ignition sources; such as pilot lights, cigarettes, portable electric lamps, and plastic drop cloths (potential static arc). • Do not plug or unplug power cords or turn lights on or off when flammable fumes are present. • Keep work area free of debris, including solvent, rags and gasoline. • Check gun resistance daily. • Keep a working fire extinguisher in the work area.
	<p>SPECIAL CONDITIONS FOR SAFE USE</p> <p>Equipment must comply with the following conditions to avoid a hazardous condition which can cause fire or explosion.</p> <ul style="list-style-type: none"> • All label and marking material must be cleaned with a damp cloth (or equivalent). • The electronic monitoring system is required to be grounded. See Grounding instructions.
	<p>ELECTRIC SHOCK HAZARD</p> <p>This equipment must be grounded. Improper grounding, setup, or usage of the system can cause electric shock.</p> <ul style="list-style-type: none"> • Turn off air supply before servicing equipment. • All electrical wiring must be done by a qualified electrician and comply with all local codes and regulations. • Do not touch gun electrode when electrostatics are on. • Do not expose to rain. Store indoors.

! WARNING



SKIN INJECTION HAZARD

High-pressure fluid from gun, hose leaks, or ruptured components will pierce skin. This may look like just a cut, but it is a serious injury that can result in amputation. **Get immediate surgical treatment.**

- Do not spray without tip guard and trigger guard installed.
- Engage trigger lock when not spraying.
- Do not point gun at anyone or at any part of the body.
- Do not put your hand over the spray tip.
- Do not stop or deflect leaks with your hand, body, glove, or rag.
- Follow the **Pressure Relief Procedure** when you stop spraying and before cleaning, checking, or servicing equipment.
- Tighten all fluid connections before operating the equipment.
- Check hoses and couplings daily. Replace worn or damaged parts immediately.



EQUIPMENT MISUSE HAZARD

Misuse can cause death or serious injury.

- Do not operate the unit when fatigued or under the influence of drugs or alcohol.
- Do not exceed the maximum working pressure or temperature rating of the lowest rated system component. See **Technical Data** in all equipment manuals.
- Use fluids and solvents that are compatible with equipment wetted parts. See **Technical Data** in all equipment manuals. Read fluid and solvent manufacturer's warnings. For complete information about your material, request MSDS from distributor or retailer.
- Do not leave the work area while equipment is energized or under pressure. Turn off all equipment and follow the **Pressure Relief Procedure** when equipment is not in use.
- Check equipment daily. Repair or replace worn or damaged parts immediately with genuine manufacturer's replacement parts only.
- Do not alter or modify equipment.
- Use equipment only for its intended purpose. Call your distributor for information.
- Route hoses and cables away from traffic areas, sharp edges, moving parts, and hot surfaces.
- Do not kink or over bend hoses or use hoses to pull equipment.
- Keep children and animals away from work area.
- Comply with all applicable safety regulations.



MOVING PARTS HAZARD

Moving parts can pinch, cut or amputate fingers and other body parts.

- Keep clear of moving parts.
- Do not operate equipment with protective guards or covers removed.
- Pressurized equipment can start without warning. Before checking, moving, or servicing equipment, follow the **Pressure Relief Procedure** and disconnect all power sources.



TOXIC FLUID OR FUMES HAZARD

Toxic fluids or fumes can cause serious injury or death if splashed in the eyes or on skin, inhaled, or swallowed.

- Read MSDSs to know the specific hazards of the fluids you are using.
- Store hazardous fluid in approved containers, and dispose of it according to applicable guidelines.
- Always wear chemically impermeable gloves when spraying, dispensing, or cleaning equipment.

WARNING







PERSONAL PROTECTIVE EQUIPMENT

You must wear appropriate protective equipment when operating, servicing, or when in the operating area of the equipment to help protect you from serious injury, including eye injury, hearing loss, inhalation of toxic fumes, and burns. This equipment includes but is not limited to:

- Protective eyewear, and hearing protection.
- Respirators, protective clothing, and gloves as recommended by the fluid and solvent manufacturer.

Important Two-Component Material Information

Isocyanate Conditions

						
---	---	---	---	---	--	--



Spraying or dispensing materials containing isocyanates creates potentially harmful mists, vapors, and atomized particulates.

Read material manufacturer's warnings and material MSDS to know specific hazards and precautions related to isocyanates.

Prevent inhalation of isocyanate mists, vapors, and atomized particulates by providing sufficient ventilation in the work area. If sufficient ventilation is not available, a supplied-air respirator is required for everyone in the work area.



To prevent contact with isocyanates, appropriate personal protective equipment, including chemically impermeable gloves, boots, aprons, and goggles, is also required for everyone in the work area.

Material Self-ignition

						
---	---	--	--	--	--	--

Some materials may become self-igniting if applied too thickly. Read material manufacturer's warnings and material MSDS.

Keep Components A and B Separate

						
---	---	--	--	--	--	--

Cross-contamination can result in cured material in fluid lines which could cause serious injury or damage equipment. To prevent cross-contamination of the equipment's wetted parts, **never** interchange component A (isocyanate) and component B (resin) parts.

Moisture Sensitivity of Isocyanates

Isocyanates (ISO) are catalysts used in two component coatings. ISO will react with moisture (such as humidity) to form small, hard, abrasive crystals, which become suspended in the fluid. Eventually a film will form on the surface and the ISO will begin to gel, increasing in viscosity. If used, this partially cured ISO will reduce performance and the life of all wetted parts.

NOTE: The amount of film formation and rate of crystallization varies depending on the blend of ISO, the humidity, and the temperature.

To prevent exposing ISO to moisture:

- Always use a sealed container with a desiccant dryer in the vent, or a nitrogen atmosphere. **Never** store ISO in an open container.
- Use moisture-proof hoses specifically designed for ISO, such as those supplied with your system.
- Never use reclaimed solvents, which may contain moisture. Always keep solvent containers closed when not in use.
- Never use solvent on one side if it has been contaminated from the other side.
- Always lubricate threaded parts with ISO pump oil or grease when reassembling.

Changing Materials

- When changing materials, flush the equipment multiple times to ensure it is thoroughly clean.
- Always clean the fluid inlet strainers after flushing.
- Check with your material manufacturer for chemical compatibility.
- Most materials use ISO on the A side, but some use ISO on the B side.



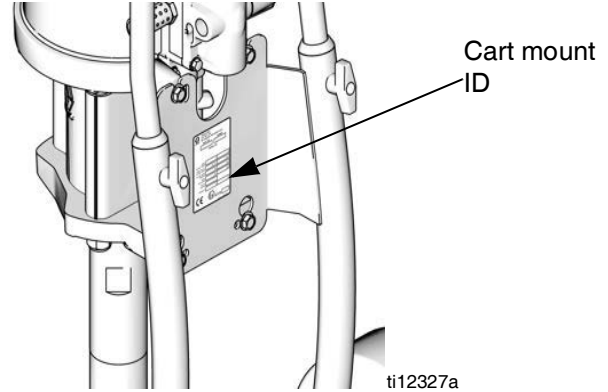
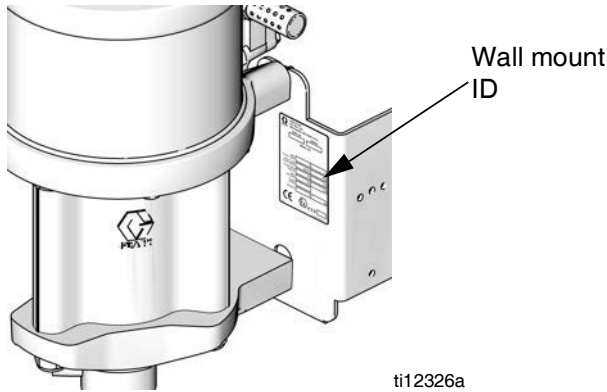

Models

Check the identification plate (ID) for the 6-digit part number of your package. Use the following matrix and tables to define the components of your package. For example, package number **G30C76** represents a Merkur package (**G**), with a 30:1 ratio pump (**30**), cart mounting (**C**), and the components shown for (**76**) in the table on page 13.



G	30		C		76
First Digit	Second and Third Digits (Ratio)		Fourth Digit (Package Type)		Fifth and Sixth Digit (Components Included)
G (Merkur Package)	15	15:1	C	Cart Mount	See Tables, pages 9 - 13
	18	18:1	W	Wall Mount	
	23	23:1	B	Bellows Pump - Cart or Wall Mount	
	24	24:1			
	28	28:1			
	30	30:1			
	35	35:1			

Agency Approvals

Merkur Electrostatic Packages G15W57, G15C85, G18W11, G18C09, G23W13, G23C15, G24W11, G24C13, G28W15, G28C13, G30W77, G30C75, G15B83, G23B33, G24B33, G35B33, G30C95	 II 2 G Ex h IIB T6 Gb
Merkur Electrostatic Packages with DataTrak G15W18, G15C86, G18W12, G18C10, G23W14, G23C16, G24W12, G24C14, G28W16, G28C14, G30W78, G30C76, G15B84, G23B34, G24B34, G35B34	 II 2(1) G Ex h [ia Ga] IIA T3 Gb X
Merkur Heated Electrostatic Packages G18W13, G28W21, G28W23, G28C19, G28C21, G30W83, G28W85, G30C81, G30C83	 II 2 G Ex db h IIB T4 Gb X
Merkur Heated Electrostatic Packages with DataTrak G18W14, G28W22, G28W24, G28C20, G28C22, G30W84, G30W86, G30C82, G30C84	 II 2(1) G Ex db h [ia Ga] IIA T3 Gb X
Pro™ Xp 85 Manual Electrostatic Air-Assisted Spray Gun	See your Pro Xp AA Spray Gun manual (3A2495)
DataTrak™ Module	See your DataTrak Kits manual (313541)

Merkur 15:1 Packages, Ambient (G15Wxx and G15Cxx)

Maximum Inlet Air Pressure 100 psi (0.7 MPa, 7 bar)

Maximum Fluid Working Pressure: 1500 psi (10.3 MPa, 103 bar)

Model		Pump Assembly	Maximum fluid flow rate gpm (lpm)	Pump and Gun Air Controls	Hoses				Options		
Wall Mount	Cart Mount				Gun Fluid Hose	Gun Fluid Whip Hose	Gun Air Hose	Gun Air Whip Hose	Siphon Kit	Fluid Filter	DataTrak
G15W57	G15C85	W15FAS	2.4 (9.0)	✓	✓	✓	✓	✓	✓	✓	
G15W58	G15C86	W15FBS	2.4 (9.0)	✓	✓	✓	✓	✓	✓	✓	✓

Merkur Bellows 15:1 Packages, Ambient (G15Bxx)

Maximum Inlet Air Pressure 100 psi (0.7 MPa, 7 bar)

Maximum Fluid Working Pressure: 1500 psi (10.3 MPa, 103 bar)

Model	Pump Assembly	Maximum fluid flow rate gpm (lpm)	Pump and Gun Air Controls	Hoses				Options		
				Gun Fluid Hose	Gun Fluid Whip Hose	Gun Air Hose	Gun Air Whip Hose	Siphon Kit	Fluid Filter	DataTrak
G15B83	B15FA0	2.4 (9.0)	✓	✓	✓	✓	✓	✓	✓*	
G15B84	B15FB0	2.4 (9.0)	✓	✓	✓	✓	✓	✓	✓*	✓

* Fluid filter includes fluid drain valve.

Merkur 18:1 Packages, Ambient (G18Wxx and G18Cxx)

Maximum Inlet Air Pressure: 100 psi (0.7 MPa, 7 bar)

Maximum Fluid Working Pressure: 1800 psi (12.4 MPa, 124 bar)

Model		Pump Assembly	Maximum fluid flow rate gpm (lpm)	Pump and Gun Air Controls	Hoses				Options		
Wall Mount	Cart Mount				Gun Fluid Hose	Gun Fluid Whip Hose	Gun Air Hose	Gun Air Whip Hose	Siphon Kit	Fluid Filter	DataTrak
G18W11	G18C09	W18EAS	2.0 (7.5)	✓	✓	✓	✓	✓	✓	✓	
G18W12	G18C10	W18EBS	2.0 (7.5)	✓	✓	✓	✓	✓	✓	✓	✓

Merkur 18:1 Packages, Heated (G18Wxx)

Maximum Inlet Air Pressure: 100 psi (0.7 MPa, 7 bar)

Maximum Fluid Working Pressure: 1800 psi (12.4 MPa, 124 bar)

Model		Pump Assembly	Maximum fluid flow rate gpm (lpm)	Pump and Gun Air Controls	Hoses				Options		
Wall Mount					Gun Fluid Hose	Gun Fluid Whip Hose	Gun Air Hose	Gun Air Whip Hose	Siphon Kit	Fluid Filter	DataTrak
G18W13		W18EAS	2.0 (7.5)	✓	✓	✓	✓	✓	✓		
G18W14		W18EBS	2.0 (7.5)	✓	✓	✓	✓	✓	✓	✓	

Merkur 23:1 Packages, Ambient (G23Wxx and G23Cxx)

Maximum Inlet Air Pressure: 100 psi (0.7 MPa, 7 bar)

Maximum Fluid Working Pressure: 2300 psi (15.9 MPa, 159 bar)

Model		Pump Assembly	Maximum fluid flow rate gpm (lpm)	Pump and Gun Air Controls	Hoses				Options		
Wall Mount	Cart Mount				Gun Fluid Hose	Gun Fluid Whip Hose	Gun Air Hose	Gun Air Whip Hose	Siphon Kit	Fluid Filter	DataTrak
G23W13	G23C15	W23DAS	1.6 (6.0)	✓	✓	✓	✓	✓	✓	✓	
G23W14	G23C16	W23DBS	1.6 (6.0)	✓	✓	✓	✓	✓	✓	✓	✓

Merkur Bellows 23:1 Packages, Ambient(G23Bxx)

Maximum Inlet Air Pressure 100 psi (0.7 MPa, 7 bar)

Maximum Fluid Working Pressure: 2300 psi (15.9 MPa, 159 bar)

Model	Pump Assembly	Maximum fluid flow rate gpm (lpm)	Pump and Gun Air Controls	Hoses				Options		
				Gun Fluid Hose	Gun Fluid Whip Hose	Gun Air Hose	Gun Air Whip Hose	Siphon Kit	Fluid Filter	DataTrak
G23B33	B23DA0	1.6 (6.0)	✓	✓	✓	✓	✓	✓	✓*	
G23B34	B23DB0	1.6 (6.0)	✓	✓	✓	✓	✓	✓	✓*	✓

* Fluid filter includes fluid drain valve.

Merkur 24:1 Packages, Ambient (G24Wxx and G24Cxx)

Maximum Inlet Air Pressure: 100 psi (0.7 MPa, 7 bar)

Maximum Fluid Working Pressure: 2400 psi (16.5 MPa, 165 bar)

Model		Pump Assembly	Maximum fluid flow rate gpm (lpm)	Pump and Gun Air Controls	Hoses				Options		
Wall Mount	Cart Mount				Gun Fluid Hose	Gun Fluid Whip Hose	Gun Air Hose	Gun Air Whip Hose	Siphon Kit	Fluid Filter	DataTrak
G24W11	G24C13	W24FAS	2.4 (9.0)	✓	✓	✓	✓	✓	✓	✓	
G24W12	G24C14	W24FBS	2.4 (9.0)	✓	✓	✓	✓	✓	✓	✓	✓

Merkur Bellows 24:1 Packages, Ambient (G24Bxx)

Maximum Inlet Air Pressure 100 psi (0.7 MPa, 7 bar)

Maximum Fluid Working Pressure: 2400 psi (16.5 MPa, 165 bar)

Model	Pump Assembly	Maximum fluid flow rate gpm (lpm)	Pump and Gun Air Controls	Hoses				Options		
				Gun Fluid Hose	Gun Fluid Whip Hose	Gun Air Hose	Gun Air Whip Hose	Siphon Kit	Fluid Filter	DataTrak
G24B33	B24FA0	2.4 (9.0)	✓	✓	✓	✓	✓	✓	✓*	
G24B34	B24FB0	2.4 (9.0)	✓	✓	✓	✓	✓	✓	✓*	✓

* Fluid filter includes fluid drain valve.

Merkur 28:1 Packages, Ambient (G28Wxx and G28Cxx)

Maximum Inlet Air Pressure: 100 psi (0.7 MPa, 7 bar)

Maximum Fluid Working Pressure: 2800 psi (19.3 MPa, 193 bar)

Model		Pump Assembly	Maximum fluid flow rate gpm (lpm)	Pump and Gun Air Controls	Hoses				Options		
Wall Mount	Cart Mount				Gun Fluid Hose	Gun Fluid Whip Hose	Gun Air Hose	Gun Air Whip Hose	Siphon Kit	Fluid Filter	DataTrak
G28W15	G28C13	W28EAS	2.0 (7.5)	✓	✓	✓	✓	✓	✓	✓	
G28W16	G28C14	W28EBS	2.0 (7.5)	✓	✓	✓	✓	✓	✓	✓	✓
---	G28C23	W28EAS	2.0 (7.5)	✓	✓	✓	✓	✓	✓	✓	
---	G28C25	W28EAS	2.0 (7.5)	✓	✓	✓	✓	✓	✓	✓	

Merkur 28:1 Packages, Heated (G28Wxx and G28Cxx)

Maximum Inlet Air Pressure: 100 psi (0.7 MPa, 7 bar)

Maximum Fluid Working Pressure: 2800 psi (19.3 MPa, 193 bar)

Model		Pump Assembly	Maximum fluid flow rate gpm (lpm)	Heater Volt Amp	Pump and Gun Air Controls	Hoses				Options		
Wall Mount	Cart Mount					Gun Fluid Hose	Gun Fluid Whip Hose	Gun Air Hose	Gun Air Whip Hose	Siphon Kit	Fluid Filter	DataTrak
G28W21	G28C19	W28EAS	2.0 (7.5)	120V 19.2 Amp	✓	✓	✓	✓	✓	✓	✓	
G28W22	G28C20	W28EBS	2.0 (7.5)	120V 19.2 Amp	✓	✓	✓	✓	✓	✓	✓	✓
G28W23	G28C21	W28EAS	2.0 (7.5)	240V 16.7 Amp	✓	✓	✓	✓	✓	✓	✓	
G28W24	G28C22	W28EBS	2.0 (7.5)	240V 16.7 Amp	✓	✓	✓	✓	✓	✓	✓	✓

Merkur 30:1 Packages, Ambient (G30Wxx and G30Cxx)

Maximum Inlet Air Pressure: 100 psi (0.7 MPa, 7 bar)

Maximum Fluid Working Pressure: 3000 psi (20.7 MPa, 207 bar)

Model		Pump Assembly	Maximum fluid flow rate gpm (lpm)	Pump and Gun Air Controls	Hoses				Options		
Wall Mount	Cart Mount				Gun Fluid Hose	Gun Fluid Whip Hose	Gun Air Hose	Gun Air Whip Hose	Siphon Kit	Fluid Filter	DataTrak
G30W77	G30C75	W30CAS	1.2 (4.5)	✓	✓	✓	✓	✓	✓	✓	
G30W78	G30C76	W30CBS	1.2 (4.5)	✓	✓	✓	✓	✓	✓	✓	✓
---	G30C87	W30CAS	1.2 (4.5)	✓	✓	✓	✓	✓	✓	✓	
---	G30C89	W30CAS	1.2 (4.5)	✓	✓	✓	✓	✓	✓	✓	
---	G30C95	W30AAS	0.4 (1.5)	✓	✓*	✓	✓*	✓	✓	✓	

* Hoses are 50 ft long.

Merkur 30:1 Packages, Heated (G30Wxx and G30Cxx)

Maximum Inlet Air Pressure: 100 psi (0.7 MPa, 7 bar)

Maximum Fluid Working Pressure: 3000 psi (20.7 MPa, 207 bar)

Model		Pump Assembly	Maximum fluid flow rate gpm (lpm)	Heater Volt Amp	Pump and Gun Air Controls	Hoses				Options		
Wall Mount	Cart Mount					Gun Fluid Hose	Gun Fluid Whip Hose	Gun Air Hose	Gun Air Whip Hose	Siphon Kit	Fluid Filter	DataTrak
G30W83	G30C81	W30CAS	1.2 (4.5)	120V 19.2 Amp	✓	✓	✓	✓	✓	✓	✓	
G30W84	G30C82	W30CBS	1.2 (4.5)	120V 19.2 Amp	✓	✓	✓	✓	✓	✓	✓	✓
G30W85	G30C83	W30CAS	1.2 (4.5)	240V 16.7 Amp	✓	✓	✓	✓	✓	✓	✓	
G30W86	G30C84	W30CBS	1.2 (4.5)	240V 16.7 Amp	✓	✓	✓	✓	✓	✓	✓	✓

Merkur Bellows 35:1 Packages, Ambient (G35Bxx)

Maximum Inlet Air Pressure 100 psi (0.7 MPa, 7 bar)

Maximum Fluid Working Pressure: 3000 psi (20.7 MPa, 207 bar)

Model	Pump Assembly	Maximum fluid flow rate gpm (lpm)	Pump and Gun Air Controls	Hoses				Options		
				Gun Fluid Hose	Gun Fluid Whip Hose	Gun Air Hose	Gun Air Whip Hose	Siphon Kit	Fluid Filter	DataTrak
G35B33	B35DA0	1.6 (6.0)	✓	✓	✓	✓	✓	✓	✓*	
G35B34	B35DB0	1.6 (6.0)	✓	✓	✓	✓	✓	✓	✓*	✓

* Fluid filter includes fluid drain valve.

Installation

Package components vary. See page 9 to 13 to determine the components included in your model. Items designated as accessories are not included in the packages.

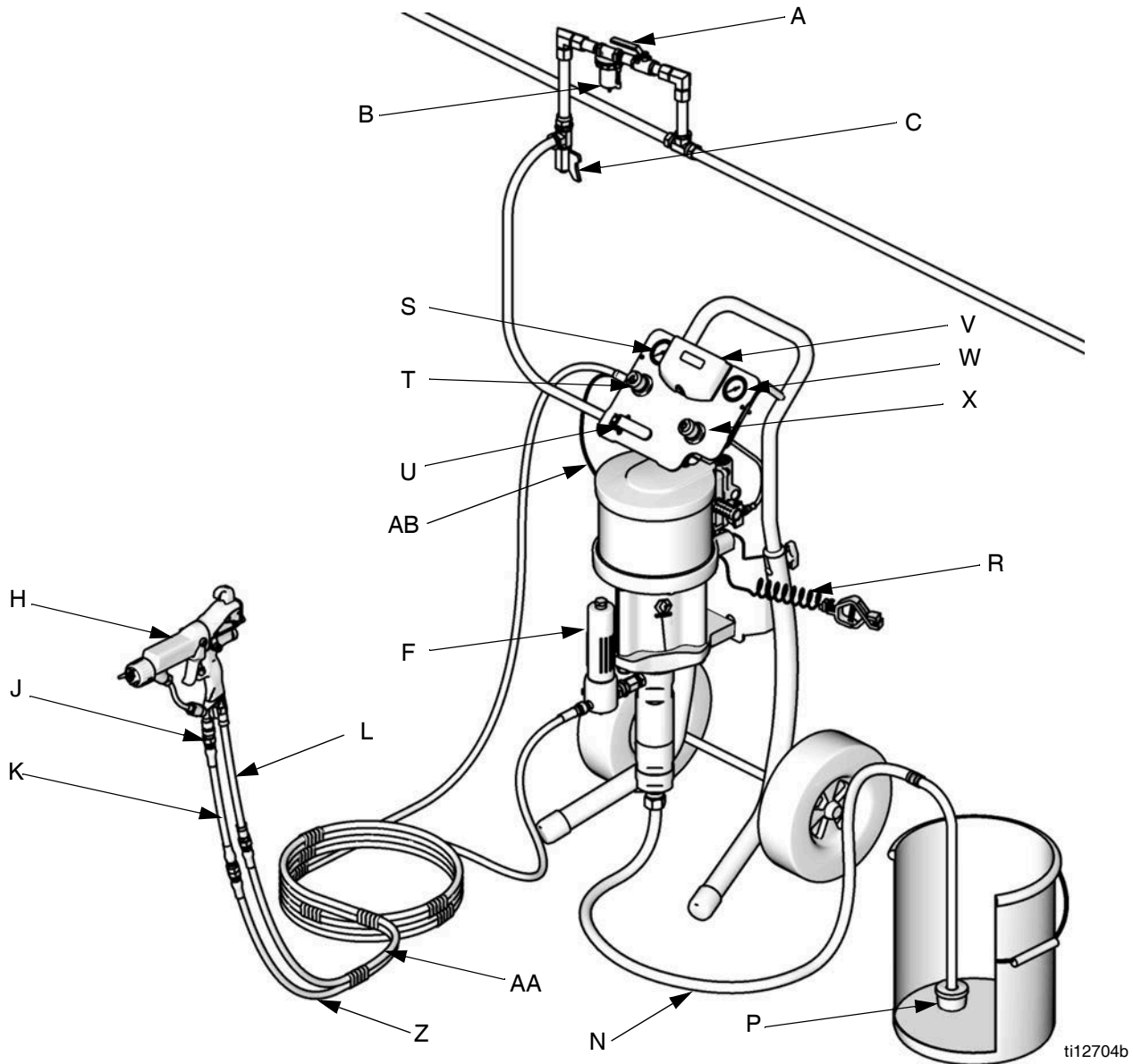

FIG. 1. Typical Installation, Ambient, Model G30C76 Shown.

Key:

- | | |
|--|--|
| A Air Shutoff Valve (accessory) | S Gun Air Pressure Gauge |
| B Air Filter (accessory) | T Gun Air Pressure Regulator |
| C Air Line Moisture Trap and Drain Valve (accessory) | U Bleed-type Master Air Valve (required) |
| F Fluid Filter | V DataTrak |
| H Electrostatic Air-Assisted Spray Gun | W Pump Air Pressure Gauge |
| J Gun Swivel | X Pump Air Pressure Regulator |
| K Fluid Whip Hose | Y Insert (for models without DataTrak), see FIG. 2 |
| L Air Whip Hose | Z Electrically Conductive Gun Fluid Hose |
| N Suction Hose and Tube | AA Electrically Conductive Gun Air Hose |
| P Strainer | AB Electrostatic Spray Gun Grounding Wire |
| R Pump Grounding Wire | |

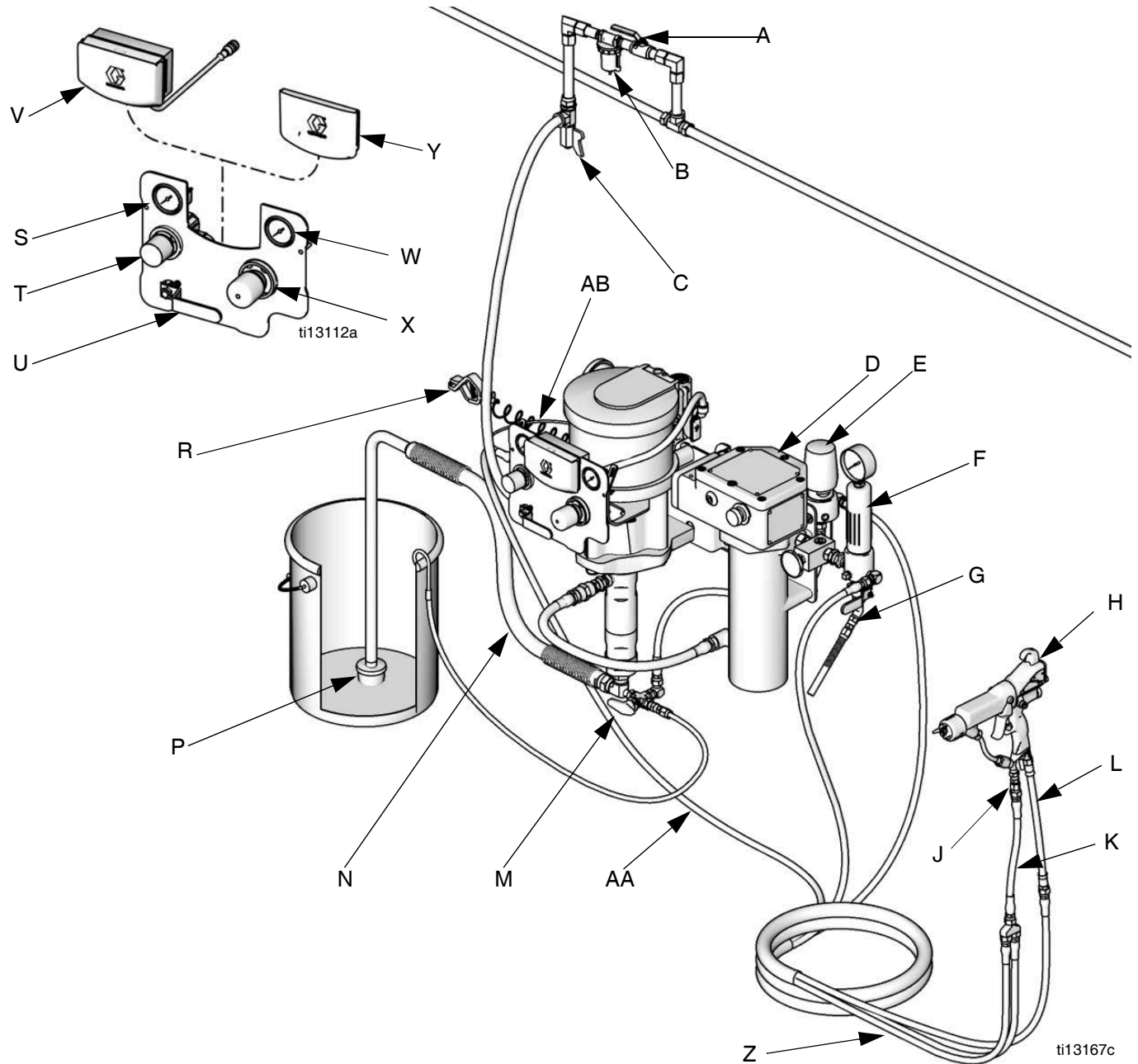

FIG. 2. Typical Installation, Heated, Model G30W86 Shown

Key:

- | | |
|--|---|
| A Air Shutoff Valve (accessory) | N Suction Hose and Tube |
| B Air Filter (accessory) | P Strainer |
| C Air Line Moisture Trap and Drain Valve (accessory) | R Pump Grounding Wire |
| D Fluid Heater | S Gun Air Pressure Gauge |
| E Back Pressure Regulator | T Gun Air Pressure Regulator |
| F Fluid Filter | U Bleed Type Master Air Valve (required) |
| G Fluid Drain Valve | V DataTrak |
| H Electrostatic Air-Assisted Spray Gun | W Pump Air Pressure Gauge |
| J Gun Swivel | X Pump Air Pressure Regulator |
| K Fluid Whip Hose | Y Insert (for models without DataTrak) |
| L Air Whip Hose | Z Electrically Conductive Heated Fluid Supply/Return Hose |
| M 3 Way Valve | AA Electrically Conductive Gun Air Hose |
| | AB Electrostatic Spray Gun Grounding Wire |

General Information

NOTE: Reference numbers and letters in parentheses in the text refer to the callouts in the figures and the parts drawing.

NOTE: Always use Genuine Graco Parts and Accessories, available from your Graco distributor. If you supply your own accessories, be sure they are adequately sized and pressure-rated for your system.

FIG. 1 and FIG. 2 are only guides for selecting and installing system components and accessories. Contact your Graco distributor for assistance in designing a system to suit your particular needs.

Prepare the Operator

All persons who operate the equipment must be trained in the operation of all system components as well as the proper handling of all fluids. All operators must thoroughly read all instruction manuals, tags, and labels before operating the equipment.

Prepare the Site

Ensure that you have an adequate compressed air supply.

NOTICE

The compressed air supply to the gun must be clean and dry, to prevent damage to the finish. Use a coalescing air filter in the main air supply line.

Bring a compressed air supply line from the air compressor to the pump location. Refer to the performance charts in your pump assembly manual to find the air consumption of your pump. Be sure all air hoses are properly sized and pressure-rated for your system. Use only electrically conductive hoses. The air hose should have a 3/8 npt(m) thread. A quick disconnect coupling is recommended.

Install a bleed-type shutoff valve (A) in the air line to isolate the air line components for servicing. Install an air line filter (B) and a moisture trap and drain valve (C) to help remove moisture and contaminants from the compressed air supply.

Keep the site clear of any obstacles or debris that could interfere with the operator's movement.

Have a grounded, metal pail available for use when flushing the system.

Mount the Pump

Mount the pump directly to the wall or to a Graco cart. See page 39 for mounting kits.

Wall-Mounted Pumps



1. Be sure the wall can support the weight of the pump, bracket, hoses and accessories, as well as the stress caused during operation.
2. Position the wall bracket about 4-5 ft (1.2-1.5 m) above the floor. For ease of operation and service, make sure the pump air inlet, fluid inlet, and fluid outlet ports are easily accessible.
3. Using the wall bracket as a template, drill 0.4 in. (10 mm) mounting holes in the wall. Wall mounting dimensions are shown on page 43.
4. Attach the bracket to the wall. Use 3/8 in. (9 mm) screws that are long enough to keep the pump from vibrating during operation.

NOTE: Be sure the bracket is level.

Cart-Mounted Pumps

Kit 24E885 is available if you plan to bolt your cart to the floor. It includes two spacers that keep the legs stable. Bolts not included.

Ventilate the Spray Booth

						
Provide fresh air ventilation to avoid the buildup of flammable or toxic vapors. Do not operate the gun unless ventilation fans are operating.						

Electrically interlock the gun air supply with the ventilators to prevent gun operation without ventilating fans operating. Check and follow all National, State, and Local codes regarding air exhaust velocity requirements.

NOTICE

High velocity air exhaust will decrease the operating efficiency of the electrostatic system. Air exhaust velocity of 100 ft/min (31 linear meters/minute) should be sufficient.

Components

See FIG. 1 or FIG. 2. **Components vary by package ordered.** See tables on pages 9 to 13. Your package may include:

- The red-handled bleed-type master air valve (U) is required in your system to relieve air trapped between it and the air motor and gun when the valve is closed. Do not block access to the valve.
- The pump air regulator (X) controls pump speed and outlet pressure by adjusting the air pressure to the pump.
- The air relief valve (not shown) opens automatically to prevent overpressurization of the pump.
- The gun air regulator (T) adjusts the air pressure to the electrostatic air-assisted spray gun (H).
- The electrostatic air-assisted spray gun (H) dispenses the fluid. The gun houses the spray tip (not shown), which is available in a wide range of sizes for different spray patterns and rates of flow. Refer to gun manual for tip installation.
- A gun swivel (J) allows freer gun movement.
- The suction hose (N) with strainer (P) allows the pump to draw fluid from a 5 gallon (19 liter) pail.

- A fluid filter (F) with a 60 mesh (250 micron) stainless steel element filters particles from fluid as it leaves the pump.
- DataTrak (V) provides pump diagnostics and material usage information. See page 27.

Supplied with Heated Electrostatic Packages Only

- The back pressure regulator (E) controls back pressure to the gun and maintains proper circulation pressure.
- The 3-way valve (M) allows choice to circulate fluid back to the pump or return it to the supply container.
- A fluid drain valve (G) relieves fluid pressure in the hose and gun.
- The fluid heater (D) heats the fluid as it passes through, to maintain the correct spraying viscosity.

Read and understand all instructions in the supplied heater manual 309524 before operating the heater.

Air and Fluid Hoses





Ambient Models

- The red hose (AA) provides the gun air supply.
- The blue hose (Z) provides the gun fluid supply.

Heated Models

- The hose bundle (L) supplies fluid and air to the gun, and allows recirculation of fluid when the gun is not triggered.

Grounding

						
<p>When operating the electrostatic gun, any ungrounded objects in the spray area (people, containers, tools, etc.) can become electrically charged. The equipment must be grounded to reduce the risk of static sparking and electric shock. Electric or static sparking can cause fumes to ignite or explode. Improper grounding can cause electric shock. Grounding provides an escape wire for the electric current.</p>						

The following are minimum grounding requirements for a basic electrostatic system. Your system may include other equipment or objects which must be grounded. Check your local electrical code for detailed grounding instructions. Your system must be connected to a true earth ground.

Pump: Verify that the ground screw (GS) is attached and tightened securely to the air motor. Connect the other end of the ground wire (R) to a true earth ground.

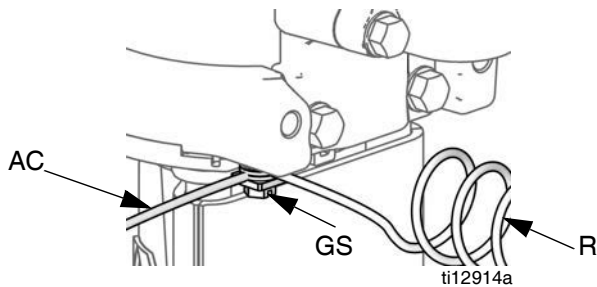

FIG. 3. Ground Screw and Wire

Electrostatic Air-Assisted Spray Gun: Use only the Graco Electrically Conductive Air Supply Hose (supplied). Connect the Gun Grounding Wire (AC) to the ground screw (GS) on the air motor.

Heater: refer to the heater manual, supplied.

Air compressor: follow manufacturer's recommendations.

All air and fluid lines must be properly grounded. Use only grounded hoses with a maximum of 500 feet (150m) combined hose length to ensure grounding continuity.

All electric cables must be properly grounded.

Object being sprayed: keep the workpiece hangers clean and grounded at all times. Follow local code.

All electrically conductive objects or devices in the spray area, including paint containers, wash cans and tools, must be properly grounded.

All persons entering the spray area: shoes must have conductive soles, such as leather, or personal grounding straps must be worn. Rubber or plastic soles are not conductive. The operator must not wear gloves that insulate the hand from the spray gun. The gloves must be conductive or modified as shown.

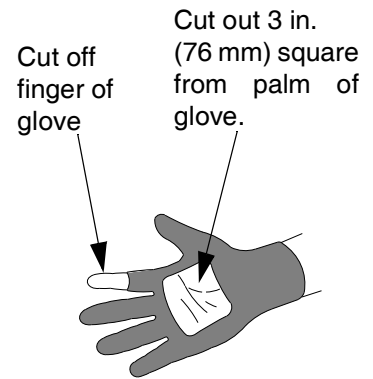

The floor of the spray area must be electrically conductive and grounded. Do not cover the floor with cardboard or any non-conductive material that would interrupt grounding continuity.

Flammable liquids in the spray area must be kept in approved, grounded containers. Do not store more than the quantity needed for one shift.

Fluid supply container: follow local code.

All solvent pails: follow local code. Use only conductive metal pails, placed on a grounded surface. Do not place the pail on a non-conductive surface, such as paper or cardboard, which interrupts grounding continuity.

To maintain grounding continuity when flushing or relieving pressure, always hold a metal part of the spray gun firmly to the side of a grounded metal pail, then trigger the gun.

Setup

Ambient Packages

1. See FIG. 1. Attach the blue fluid hose (Z) to the filter (F) outlet.
2. Attach the right-hand thread end of the air hose (AA) to the gun air regulator (T).
3. Attach the left-hand thread end of the air hose (AA) to the air whip hose (L).
4. Attach other end of the air whip hose (L) to the air inlet at base of gun.
5. Attach the gun swivel (J) to the gun fluid inlet.
6. Attach other end of the blue fluid hose (Z) to the fluid whip hose (K).
7. Attach other end of the fluid whip hose (K) to the gun swivel (J).
8. Apply lens cover to both regulator gauge lenses.
9. Verify that suction hose fittings are tight.

Heated Packages

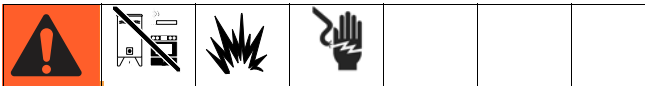

The Viscon HP Heater must be installed by a qualified electrician in compliance with all state and local codes and regulations.

Wall Mount Electrical Connections. Follow all directions and requirements in the Viscon HP Heater manual 309524.

Cart Mount Hazardous Location Wiring. The heater is shipped with a fitting that is suitable for wiring in hazardous locations. Follow all directions and requirements in the Viscon HP Heater manual 309524. **Do not use the supplied electrical cord**, which is suitable **only** for non-hazardous location wiring.

Cart Mount Non-Hazardous Location Wiring. See FIG. 4. Replace installed fitting with bushing (80), shipped loose. Attach strain relief bushing (79). Follow all directions in the Viscon HP Heater manual 309524 to connect the 120 V supplied electrical cord (78), or user-supplied cord for 240V applications.

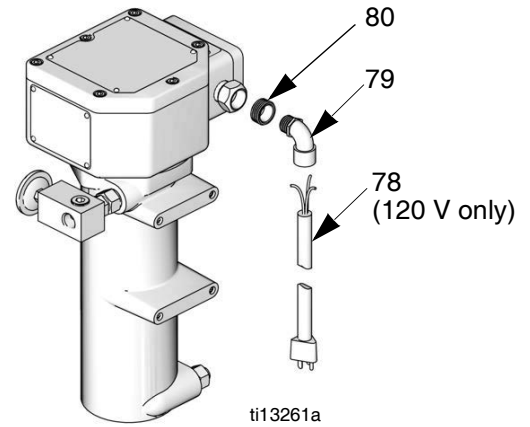
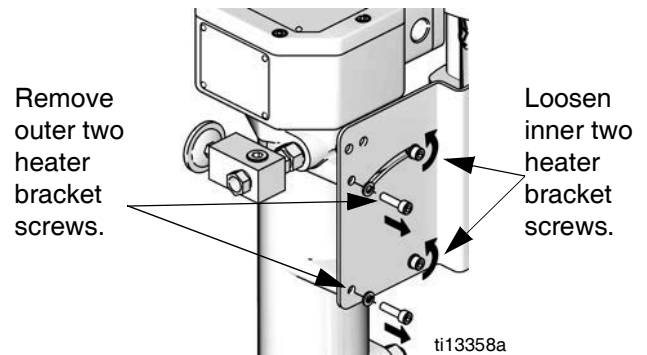
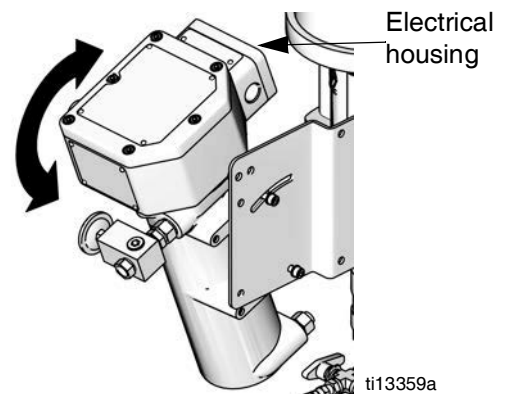

FIG. 4. Cart Mount Non-Hazardous Location Wiring

Electrical Housing Access.



Tilt the heater away from the pump for easier access to the screws on the cover of the electrical housing.



Heated Hose Connections

1. Attach the right-hand thread end of the air hose (AA) to the gun air regulator (T).
2. Attach the left-hand thread end of the air hose to the air whip hose (L).
3. Attach the other end of the air whip hose (L) to the air inlet at base of the gun.
4. Attach gun swivel (J) to the gun fluid inlet.
5. Attach one end of the fluid whip hose (K) to the gun swivel and the other end to the manifold (68).
6. Attach one blue fluid hose to the manifold (68) and to the back pressure regulator (84).
7. Attach the other blue fluid hose to the manifold (68) and to the filter (6) outlet.
8. Apply lens cover to both regulator gauge lenses.
9. Verify that suction hose fittings and drain hose fittings are tight.

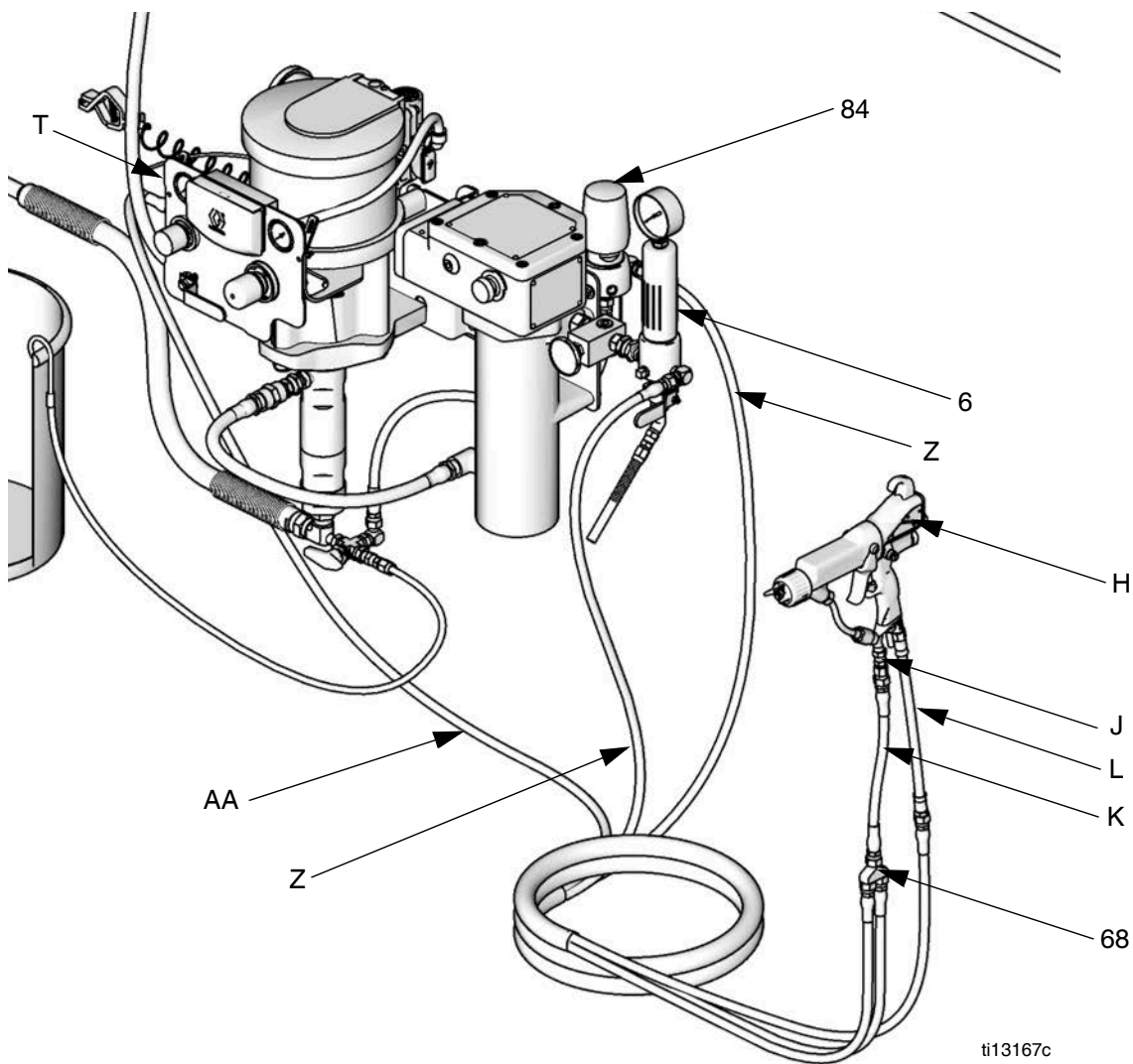

FIG. 5. Hose Setup

Operation

--	--	--	--	--	--	--

Proper electrical grounding of every part of your system is essential. Read all **Warnings**. Follow all **Grounding** instructions. See page 18. Check the gun resistance as explained in your separate gun manual.

Pressure Relief Procedure

--	--	--	--	--	--	--

1. Engage the trigger lock.
2. Turn the gun's ES ON/OFF lever to OFF.

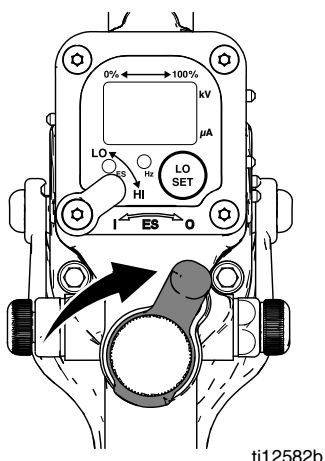

3. Close the bleed-type master air valve.
4. Disengage the trigger lock.
5. Hold a metal part of the gun firmly to a grounded metal pail. Trigger the gun to relieve pressure.
6. Engage the trigger lock.
7. Open all fluid drain valves in the system, having a waste container ready to catch drainage. Leave drain valve(s) open until you are ready to spray again.
8. If you suspect the spray tip or hose is clogged or that pressure has not been fully relieved after following the steps above, **VERY SLOWLY** loosen tip

guard retaining nut or hose end coupling to relieve pressure gradually, then loosen completely. Clear hose or tip obstruction.

Flush Before Using Equipment

The equipment was tested with lightweight oil, which is left in the fluid passages to protect parts. To avoid contaminating your fluid with oil, flush the equipment with a compatible solvent before using the equipment. See **Prime the Pump**, page 22.

Trigger Lock

Always engage the trigger lock when you stop spraying to prevent the gun from being triggered accidentally by hand or if dropped or bumped.

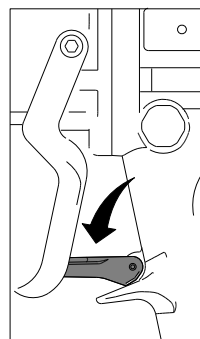

Gun Trigger Locked

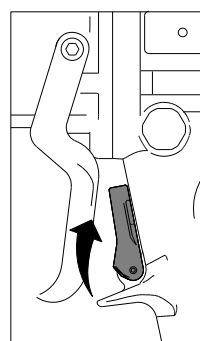

Gun Trigger Unlocked

Wet Cup



Before starting, fill wet cup 1/3 full with Graco Throat Seal Liquid (TSL) or compatible solvent.

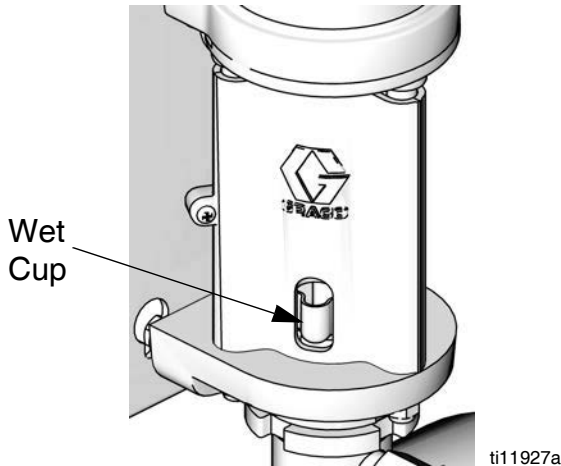

FIG. 6. Fill Wet Cup

Prime the Pump

NOTICE

For pumps with bellows, the maximum fluid inlet pressure is 15 psi (0.1 MPa, 1.0 bar). Damage to the bellows may occur if you exceed this pressure. Do not use another pump or checking device to supply the bellows pump.

1. Turn the gun's ES ON/OFF lever to OFF.
2. See FIG. 1 or FIG. 2. Lock gun trigger. Remove tip guard and spray tip from gun (H). Refer to gun manual.
3. Close gun air regulator (T) and pump air regulator (X) by turning knobs counterclockwise reducing pressure to zero. Close bleed-type air valve (U). Also verify that all drain valves are closed.
4. Connect air line to bleed type air valve (U).
5. Check that all fittings throughout system are tightened securely.
6. Position pail close to pump. Suction hose is approximately 4 ft (1.2 m) long. Do not stretch hose tight; let it hang to assist fluid flow into pump.
7. Hold metal part of gun (H) firmly to side of grounded metal pail, unlock trigger, and hold trigger open.
8. *Units with runaway protection only:* enable the prime/flush function by pushing the prime/flush button on the DataTrak.
9. Open bleed-type air valve (U). Slowly turn clockwise pump air regulator (X) increasing pressure until pump starts.
10. Cycle pump slowly until all air is pushed out and pump and hoses are fully primed.
11. *Units with runaway protection only:* disable the prime/flush function by pushing the prime/flush button on the DataTrak.
12. Release and lock gun trigger. Pump should stall against pressure.

NOTICE

Never allow the pump to run dry of the fluid being pumped. A dry pump quickly accelerates to a high speed, possibly damaging itself. If your pump accelerates quickly, or is running too fast, stop it immediately and check the fluid supply. If the supply container is empty and air has been pumped into the lines, refill the container and prime the pump and the lines with fluid, or flush and leave it filled with a compatible solvent. Be sure to eliminate all air from the fluid system.

Install the Spray Tip



Follow **Pressure Relief Procedure**, page 21. Install the spray tip and tip guard as explained in your separate gun manual, supplied. Be careful not to bend the electrode wire.

The fluid output and pattern width depend on the size of the spray tip, the fluid viscosity, and the fluid pressure. Use the Spray Tip Selection Chart in your gun instruction manual as a guide for selecting an appropriate spray tip for your application.

Adjust the Atomization



1. Do not turn on atomizing air supply.
2. Turn the gun's ES ON/OFF lever to OFF.
3. Fluid pressure is controlled by the air pressure supplied to the pump (pump air regulator). Set fluid pressure at low starting pressure. For low viscosity fluids (less than 25 sec, #2 Zahn cup) with lower percent solids (typically less than 40%), start at 300 psi (2.1 MPa, 21 bar) at pump outlet. For fluids with higher viscosity or higher solids content, start at 600 psi (4.2 MPa, 42 bar). Refer to the following example.

Example:

Pump Ratio		Pump Air Regulator Setting psi (MPa, bar)	=	Approximate Fluid Pressure psig (MPa, bar)
15:1	x	20 (0.14, 1.4)	=	300 (2.1, 21)
30:1	x	20 (0.14, 1.4)	=	600 (4.2, 42)

4. Hold gun perpendicular and approximately 12 inches (304 mm) from surface.
5. Move gun first, then pull gun trigger to spray onto test paper.
6. Increase fluid pressure in 100 psi (0.7 MPa, 7 bar) increments, just to the point where a further increase in fluid pressure does not significantly improve fluid atomization. Refer to the following example.

Example:

Pump Ratio		Pump Air Regulator Increment psi (MPa, bar)	=	Incremental Fluid Pressure psi (MPa, bar)
15:1	x	7 (.05, 0.5)	=	100 (0.7, 7.0)
30:1	x	3.3 (0.02, 0.2)	=	100 (0.7, 7.0)

Adjust the Spray Pattern

1. See FIG. 7. Close off pattern adjustment air by turning knob clockwise (in) all the way. This sets gun for its widest pattern.

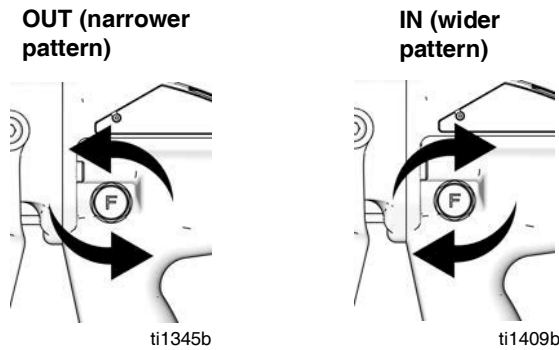

FIG. 7. Pattern Air Knob

2. See FIG. 8. Set atomizing air pressure at about 5 psi (0.35 bar, 35 kPa) when triggered. Check spray pattern, then slowly increase air pressure until tails are completely atomized and pulled into spray pattern. Do not exceed 100 psi (0.7 MPa, 7 bar) air pressure to gun.

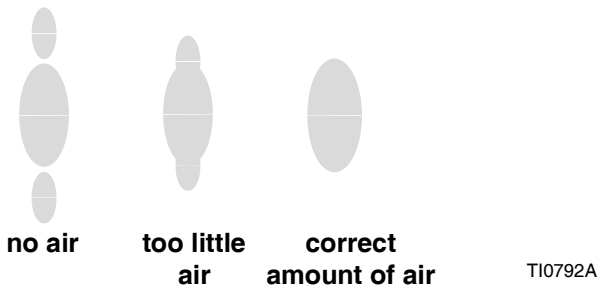

FIG. 8. Spray Pattern Problems

3. For narrower pattern, turn pattern adjustment valve knob counterclockwise (out). If pattern is still not narrow enough, increase air pressure to gun slightly or use different size tip.

NOTE: Follow directions in your gun operation manual (supplied) to test the electrostatics and to check coverage and wrap on a test piece. See Troubleshooting in your gun operation manual if there is a problem.

Shutdown



Follow **Pressure Relief Procedure**, page 21.

Always flush the pump before the fluid dries on the displacement rod. See **Flush the Pump** on page 25.

Maintenance

Preventive Maintenance Schedule

The operating conditions of your particular system determine how often maintenance is required. Establish a preventive maintenance schedule by recording when and what kind of maintenance is needed, and then determine a regular schedule for checking your system.

Replace lens covers on regulator gauge lenses when dirt makes gauges difficult to read.

Tighten Threaded Connections

Before each use, check all hoses for wear or damage. Replace as necessary. Check that all threaded connections are tight and leak-free.

Flush the Pump

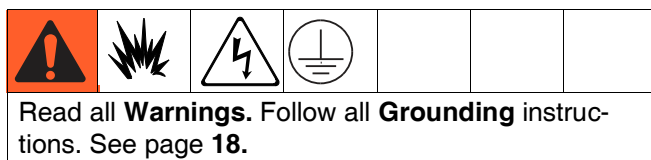

Flush the pump:

- Before first use
- When changing colors or fluids
- Before repairing equipment
- Before fluid dries or settles out in a dormant pump (check the pot life of catalyzed fluids)
- At the end of the day
- Before storing the pump.

Flush at the lowest pressure possible. Flush with a fluid that is compatible with the fluid you are pumping and with the wetted parts in your system. Check with your fluid manufacturer or supplier for recommended flushing fluids and flushing frequency.

1. Follow **Pressure Relief Procedure**, page 21.
2. Be sure the ES ON/OFF lever is turned to OFF.

3. Remove the tip guard and spray tip from gun. Refer to separate gun manual.
4. Place siphon tube in grounded metal pail containing cleaning fluid.
5. Set pump to lowest possible fluid pressure, and start pump.
6. Hold a metal part of the gun firmly to a grounded metal pail.
7. *Units with runaway protection only:* enable the prime/flush function by pushing the prime/flush button on the DataTrak.
8. Trigger gun. Flush system until clear solvent flows from gun.
9. *Units with runaway protection only:* disable the prime/flush function by pushing the prime/flush button on the DataTrak.
10. Follow **Pressure Relief Procedure**, page 21.
11. Clean the tip guard, spray tip, and fluid filter element separately, then reinstall them.
12. Clean the inside and outside of the suction tube.

Wet Cup

Fill the wet cup one-half full with Graco Throat Seal Liquid (TSL). Maintain level daily.

Troubleshooting

						
<p>Relieve the pressure before checking or servicing the equipment.</p>						

- Check all possible problems and causes before disassembling the pump.
- For all problems related to the electrostatics, see Troubleshooting in your gun manual.

Problem	Cause	Solution
Pump fails to operate.	Restricted line or inadequate air supply; closed or clogged valves.	Clear line or increase air supply. Check that the valves are open.
	Obstructed fluid hose or gun; fluid hose ID is too small.	Open, clear*; use hose with larger ID.
	Fluid dried on the displacement rod.	Clean; always stop the pump at the bottom of its stroke; keep the wet-cup 1/3 filled with Graco throat seal liquid (TSL).
	Dirty, worn, or damaged air motor parts.	Clean or repair air motor. See manual 312796.
	DataTrak models only: Air valve cannot cycle because solenoid pin is extended	Enable runaway protection (See DataTrak Operation, Setup Mode , page 28). Bleed air from motor. Press  on the DataTrak display to retract solenoid pin.
Pump operates, but output is low on both strokes.	Restricted line or inadequate air supply; closed or clogged valves.	Clear line or increase air supply. Check that the valves are open.
	Obstructed fluid hose or gun; fluid hose ID is too small.	Open, clear*; use hose with larger ID.
	Worn packings in displacement pump.	Replace packings. See manual 312792.
Pump operates, but output is low on downstroke.	Held open or worn ball check valves or piston packings.	Clear valve; replace packings. See manual 312794.
Erratic or accelerated pump speed.	Exhausted fluid supply.	Refill and prime.
	Held open or worn ball check valves or packings.	Clear valve, replace packings; see manual 312794.
Fluid being pumped is visible in the TSL reservoir.	Worn throat packings.	Replace throat packings. See manual 312794.
Fluid is visible in the overflow chamber.	Damaged bellows.	Replace. See manual 312793.

* To determine if the fluid hose or gun is obstructed, relieve the pressure. Disconnect the fluid hose and place a container at the pump fluid outlet to catch any fluid. Turn on the air just enough to start the pump. If the pump starts when the air is turned on, the obstruction is in the hose or gun.

DataTrak Controls and Indicators

Key for FIG. 9

- AA Runaway Limit, in cycles per minute (user settable; 00=OFF)
- AB Lower Displacement (user settable)
- AC Flow Rate Units (user settable to \updownarrow /min, gpm [US], gpm [Imperial], oz/min [US], oz/min [Imperial], l/min, or cc/min)
- AD LED (fault indicator when lit)
- AE Display
- PF Prime/Flush Key (Enables Prime/Flush mode. While in Prime/Flush mode, runaway protection is disabled and the batch totalizer [BT] will not count.) LED will flash while in Prime/Flush mode.

- RK Reset Key (Resets faults. Press and hold for 3 seconds to clear the batch totalizer.) Push to toggle between flow rate and cycle rate. With runaway protection enabled, push to extend and retract the solenoid pin.
- CF Cycle/Flow Rate
- BT Batch Totalizer
- GT Grand Totalizer
- RT Runaway Toggle (enable/disable)
- UT E1 Toggle
- DT E2 Toggle
- ST E5 Toggle

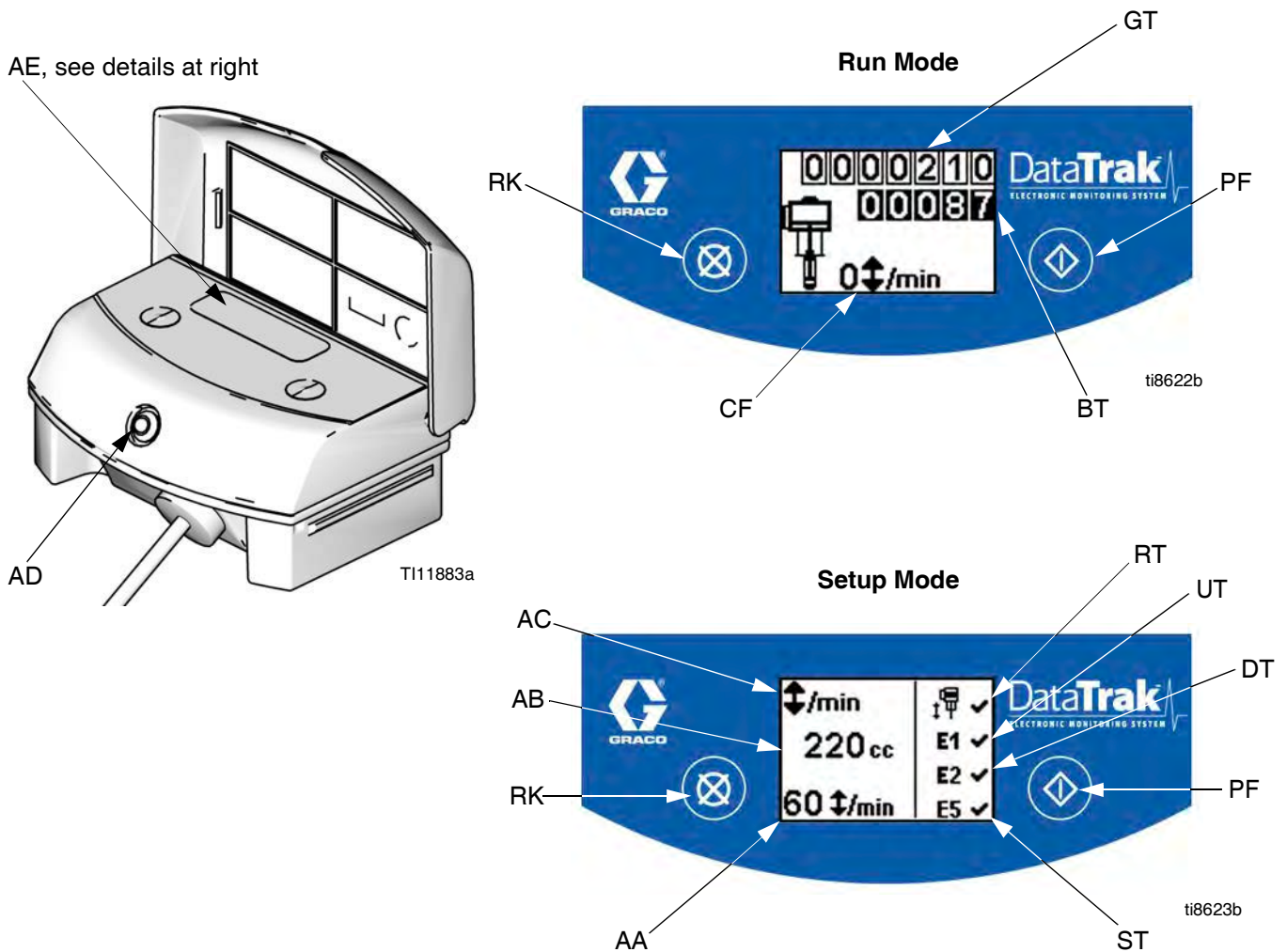

FIG. 9. DataTrak Controls and Indicators



DataTrak Operation

NOTE: The display (AE) will turn off after 1 minute to save battery life. Press any key to wake up the display.

NOTICE

To prevent damage to the softkey buttons, do not press the buttons with sharp objects such as pens, plastic cards, or fingernails.

Setup Mode

1. See FIG. 9. Press and hold  for 5 seconds until Setup menu appears.
2. To enter settings for runaway (if equipped), lower size, and flow rate units, and to enable runaway, E1, E2, and E5 error options, press  to change the value, then  to save the value and move the cursor to the next data field. See page 30 for a description of E1, E2, and E5 error codes.

NOTE: Graco recommends setting runaway (if equipped) to 60 . All DataTrak modules are shipped with runaway protection not enabled.

NOTE: When runaway, E1, E2, and E5 error options are enabled, a ✓ will appear on the setup screen. See FIG. 9.

3. Move the cursor to the E5 error enable option field, then press  once more to exit Setup mode.

Run Mode

Runaway

NOTE: DataTrak is available with and without runaway protection. Packages with M02xxx air motors ship without a runaway solenoid. All other packages are equipped with a runaway solenoid.

1. See FIG. 9. If pump runaway occurs, the runaway solenoid will actuate, stopping the pump. The LED (AD) will flash and the display (AE) will indicate a runaway condition (see Table 1). The display will cycle through six instruction screens.

2. Runaway Screens 1 and 2: To reset the runaway solenoid, close the master air valve (U). Wait for air to completely bleed off the air motor.

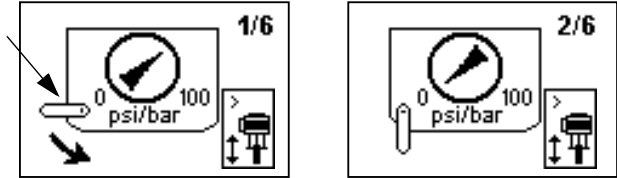

3. Runaway Screens 3 and 4: After the air is bled off, push the solenoid release button down to reset the air valve. The button will pop back up when the air valve is repressurized.

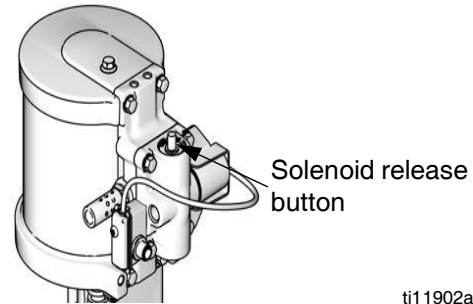
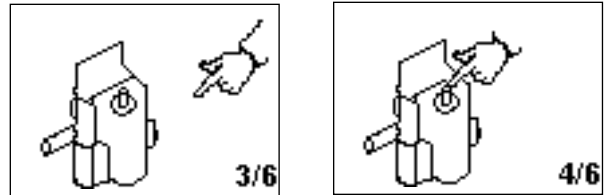

ti11902a

FIG. 10. Reset the Air Valve

4. Runaway Screens 5 and 6: Press  to clear the diagnostic code and reset the runaway solenoid.

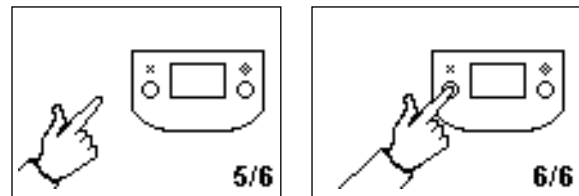

5. Open master air valve (U) to restart pump.

NOTE: To disable runaway monitoring, go to setup mode and set runaway value to 0 (zero) or toggle (RT) off  (see FIG. 9).

Prime/Flush

1. See FIG. 9. To enter Prime/Flush mode, press any key to wake up the display, then press . The Prime/Flush symbol will appear in the display and

the LED will flash

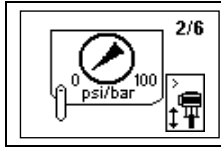

2. While in Prime/Flush mode, runaway protection is disabled and the batch totalizer (BT) will not count. The grand totalizer (GT) continues to count.
3. To exit Prime/Flush mode, press any key to wake up the display, then press . The Prime/Flush symbol will disappear from the display and the LED will stop flashing.

Counter/Totalizer

See FIG. 9. The last digit of the batch totalizer (BT) represents tenths of gallons or liters. To reset the totalizer, press any key to wake up the display, then press and hold  for 3 seconds.

- If AC is set to gallons or ounces, BT and GT display gallons.
- If AC is set to liters or cc, BT and GT display liters.
- If AC is set to cycles, BT and GT display cycles.

Press  to toggle between flow rate units and cycles. A letter under the BT display indicates that both BT and GT are displaying gallons (g) or liters (l). No letter means both BT and GT are displaying cycles.

Display

See FIG. 9. The display (AE) will turn off after 1 minute of inactivity in Run mode or 3 minutes in Setup mode. Press any key to wake up the display.

NOTE: DataTrak will continue to count cycles when display is off.

NOTE: The display (AE) may turn off if a high-level static discharge is applied to the DataTrak. Press any key to wake up the display.

Diagnostics

DataTrak can diagnose several problems with the pump. When the monitor detects a problem, the LED (AD, FIG. 9) will flash and a diagnostic code will appear on the display. See Table 1.



To acknowledge the diagnosis and return to the normal operating screen, press  once to wake up the display, and once more to clear the diagnostic code screen.

Table 1: Diagnostic Codes

Symbol	Code	Code Name	Diagnosis	Cause
<p>1/6, 2/6, 3/6, 4/6, 5/6, 6/6</p>		Runaway (DataTrak only)	Pump running faster than set runaway limit.	<ul style="list-style-type: none"> Increased air pressure. Increased fluid output. Exhausted fluid supply.
<p>E4</p>	E-1	Diving Up	Leak during upstroke.	Worn piston valve or packings.
<p>E4</p>	E-2	Diving Down	Leak during downstroke.	Worn intake valve.
<p>E3</p>	E-3	Low Battery	Battery voltage too low to stop runaway.	Low battery. Replace battery; see page 31.
<p>E4</p>	E-4	Service Component 1 (units with runaway protection only)	Problem with stopping runaway.	<ul style="list-style-type: none"> Damaged solenoid. Damaged valve carriage. Runaway (RT, FIG. 9) protection may be enabled with pump that is not equipped with a runaway solenoid valve. Enter setup screen and disable runaway protection.
<p>E4</p>	E-4	Disconnected Solenoid (units with runaway protection only)	Solenoid is disconnected.	<ul style="list-style-type: none"> Solenoid unplugged. Damaged solenoid wires.
			Solenoid is not engaging piston cup	<ul style="list-style-type: none"> Bracket and solenoid not tight against air valve housing.
<p>E5</p>	E-5	Service Component 2	Problem with sensing valve movement.	<ul style="list-style-type: none"> Sensors unplugged. Sensors mounted incorrectly. Damaged sensors. Damaged valve carriage.
<p>E6 Fuse 63 mA</p>	E-6	Blown Fuse	Fuse is blown. Replace fuse; see page 31.	<ul style="list-style-type: none"> Faulty solenoid or solenoid wiring. Extreme temperatures (above 140°F [60°C]). Runaway (RT, FIG. 9) protection may be enabled with pump that is not equipped with a runaway solenoid valve. Enter setup screen and disable runaway protection.

Replace DataTrak Battery or Fuse

						
<p>To reduce the risk of fire and explosion, the battery and fuse must be replaced in a non-hazardous location.</p> <p>Use only an approved replacement battery, shown in TABLE 2, and an approved fuse, shown in TABLE 3. Use of an unapproved battery or fuse will void Graco's warranty and Intertek and Ex approvals.</p>						

Replace Battery

1. Unscrew cable from the back of the reed switch assembly. See FIG. 11.
2. Remove the cable from the two cable clips.

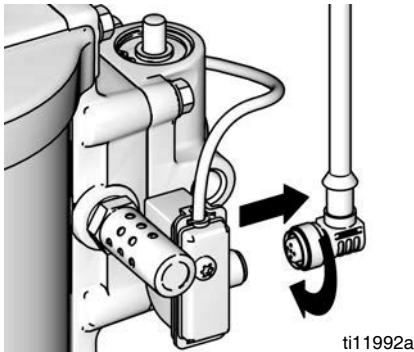

FIG. 11. Disconnect DataTrak

3. Remove DataTrak module from bracket. See FIG. 12. Take module and attached cable to a non-hazardous location.

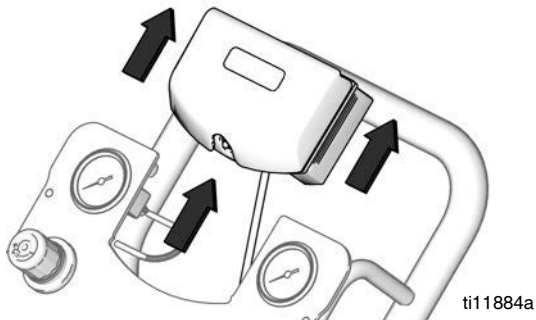

FIG. 12. Remove DataTrak

4. Remove two screws on back of module to access battery.
5. Disconnect the used battery and replace with an approved battery. See Table 2.

Table 2. Approved Batteries
Energizer alkaline # 522
Varta alkaline # 4922
Ultralife lithium # U9VL
Duracell alkaline # MN1604

Replace Fuse

1. Remove the screw, metal strap, and plastic holder.
2. Pull the fuse away from the board.
3. Replace with an approved fuse from Table 3.

DataTrak Part Number	Series*	Fuse Required
289822	A or B	24C580
	C and later	24V216
All other part numbers	A	24C580
	B and later	24V216

* FIG. 13 shows where to find the Series letter.

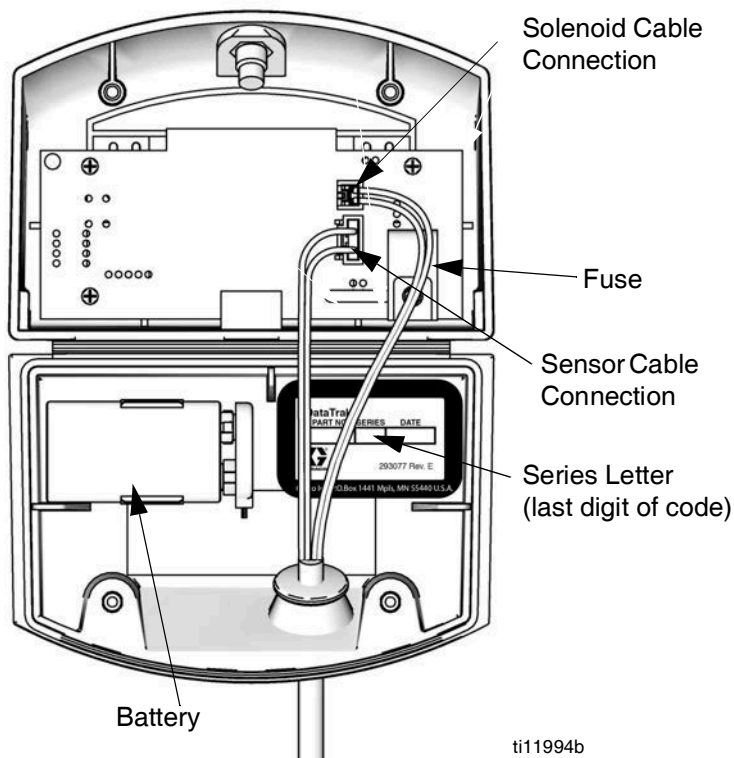
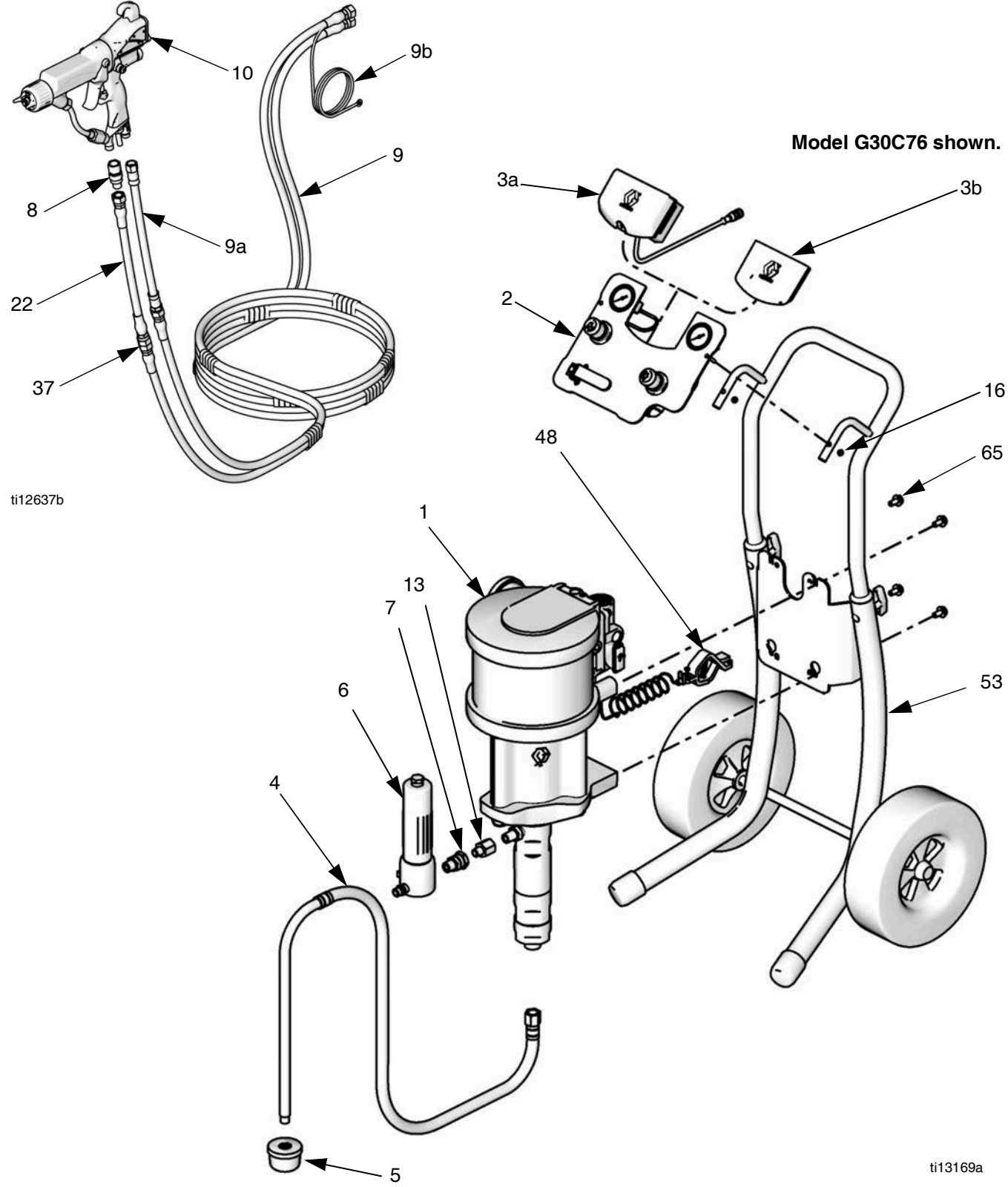

FIG. 13. DataTrak Battery and Fuse Location

Parts

Ambient Models, Cart Mount or Wall Mount



Bellows, Cart Mount

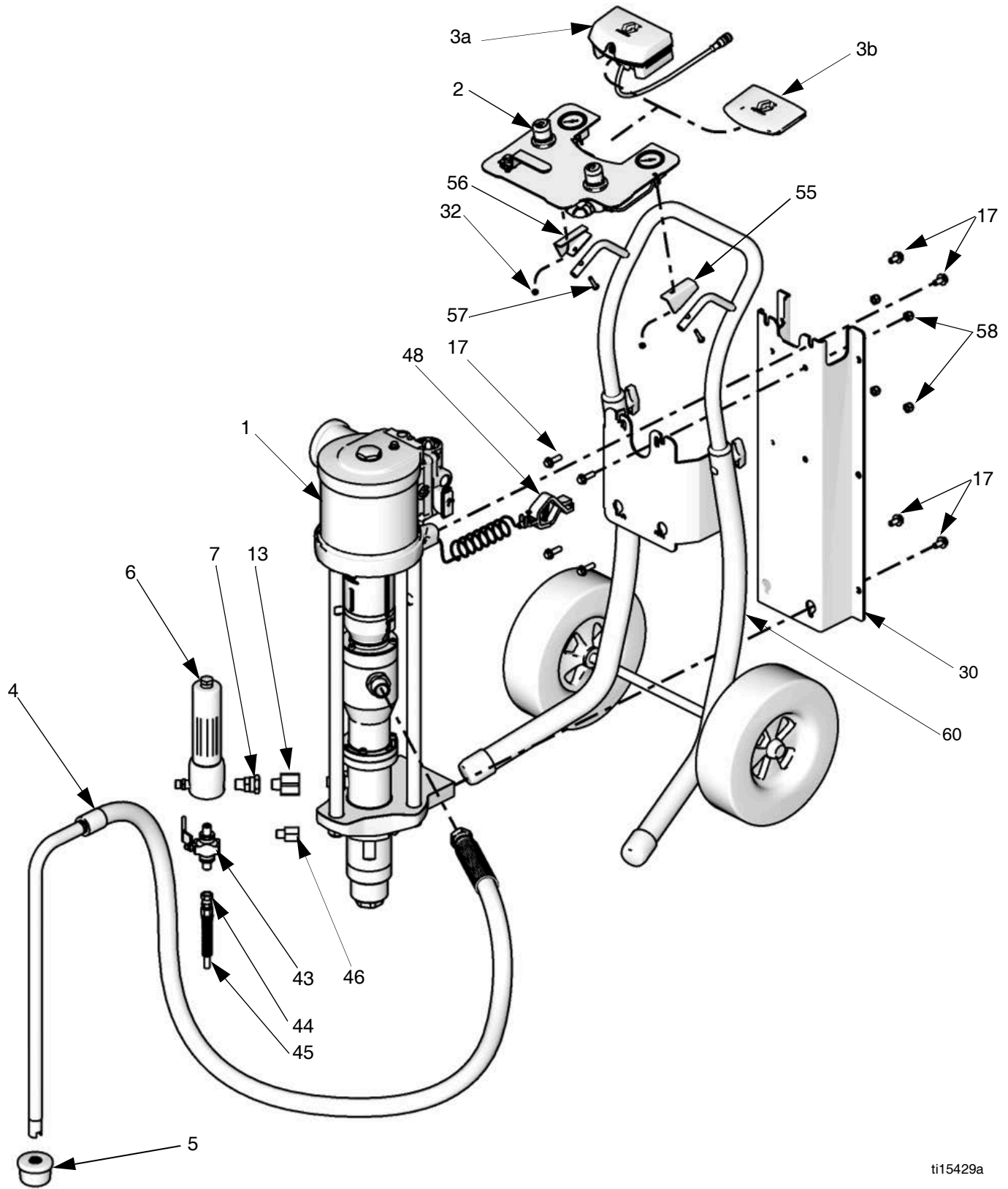

ti15429a

Parts

Ref	Part	Description	Qty
1	Varies	Pump Assembly, <i>see Model tables, pages 9-13, and Manual 312794 or 312795 (Bellows)</i>	1
2	24A581 24A584	PANEL, air control, <i>see page 41</i> G15xxx to G30xxx models G35xxx models, 85 psi	1
3a	24A576	DATATRAK, assembly; <i>see manual 313541</i>	1
3b	-----	INSERT, panel (included with Part 2)	1
4	256422 256424 256421 256423	HOSE, suction (includes Part 5) G15Cxx, G18Cxx, G24Cxx, G28Cxx G15Bxx, G15Wxx, G18Wxx, G24Bxx, G24Wxx, G28Wxxx G23Cxx, G30Cxx G23Bxx, G23Wxx, G30Wxx, G35Bxx	1
5	-----	STRAINER (included with Part 4)	1
6	24A587	FILTER, fluid (includes Part 7)	1
7	235208	FITTING, union, 3/8-18 npsm x 3/8-18 npt (included with Part 6)	1
8	189018	SWIVEL, fluid hose	1
9	24A956 244967 24B562	HOSE, coupled, air and fluid, 25 ft. (includes Parts 9a and 9b) (all models except G30C95) HOSE, air, 50 ft. (G30C95 only) HOSE, fluid, 50 ft. (G30C95 only)	1 1 1
9a	236130	HOSE, air whip, 3 ft.(0.9 m) (included with Part 9: all models except G30C95).	1
	236131	HOSE, air whip, 6 ft. (1.8 m). G30C95 only.	
9b	-----	GROUND WIRE, spray gun (included with Part 9)	1
10	H60T10 H85T10 H85M10	GUN, Pro Xp 60 (G28C23, G30C87) Pro Xp 85 (G28C25, G30C89) Pro Xp 85; Smart (All other models)	1
11	AEM413	TIP (not shown)	1
12	AEMxxx AEFxxx	TIP OPTION (not shown)	1
13	121237 121238	ADAPTER, outlet 3/8 nptm x 1/2 nptf, used on G18xxx and G28xxx models 3/8 nptm x 3/4 nptf, used on G15xxx and G24xxx models	1

Ref	Part	Description	Qty
22	26B598	HOSE, fluid, whip, 2 ft. (0.6 m), all models except G30C95.	1
	236135	HOSE, fluid, whip, 6 ft (1.8 m), G30C95 only.	
37	166846	ADAPTER, for fluid whip hose, 1/4 npt x 1/4 npsm	1
41	256425	VALVE, drain, stainless steel (includes Parts 44 and 45); Bellows packages only	1
44	-----	COUPLING, hose, drain (included with Part 41)	1
45	-----	HOSE, drain (included with Part 41)	1
48	238909	WIRE, grounding assembly	1
85▲	15W718	LABEL, warning, not shown	1
86▲	15W719	LABEL, warning, not shown	1

Non-Bellows Mounting Parts

Ref	Part	Description	Qty
16	-----	NUT, lock, M5 x 0.08 (included with Part 49)	2
49	24E883	AIR CONTROLS MOUNTING KIT, wall, (includes 16 and 51)	1
51	-----	SCREW, hex head, M8 x 16 mm (included with Part 49)	2
53	256427	CART MOUNTING KIT, <i>see page 39</i> (GxxCxx models only)	1
54	24A578	WALL MOUNTING KIT, <i>see page 39</i> (GxxWxx models only)	1

Bellows Mounting Parts

Ref	Part	Description	Qty
17	111799	SCREW, M8 x 16, included with Part 30	8
30	24E880	PLATE, mounting; includes hardware	1
32	105332	LOCK NUT, 5 mm	2
55	-----	MOUNTING WEDGE, left, air control panel, cart mount	1
56	-----	MOUNTING WEDGE, right, air control panel, cart mount	1
57	110873	SCREW, M5 x 0.8	2
58	104541	LOCK NUT, M8	4
60	24E879	CART MOUNTING KIT; <i>see Bellows Cart Mount Kit, page 40</i>	1

▲ Replacement Warning labels, signs, tags, and cards are available at no cost.

Heated Models, Cart Mount or Wall Mount

Model G30W86 shown

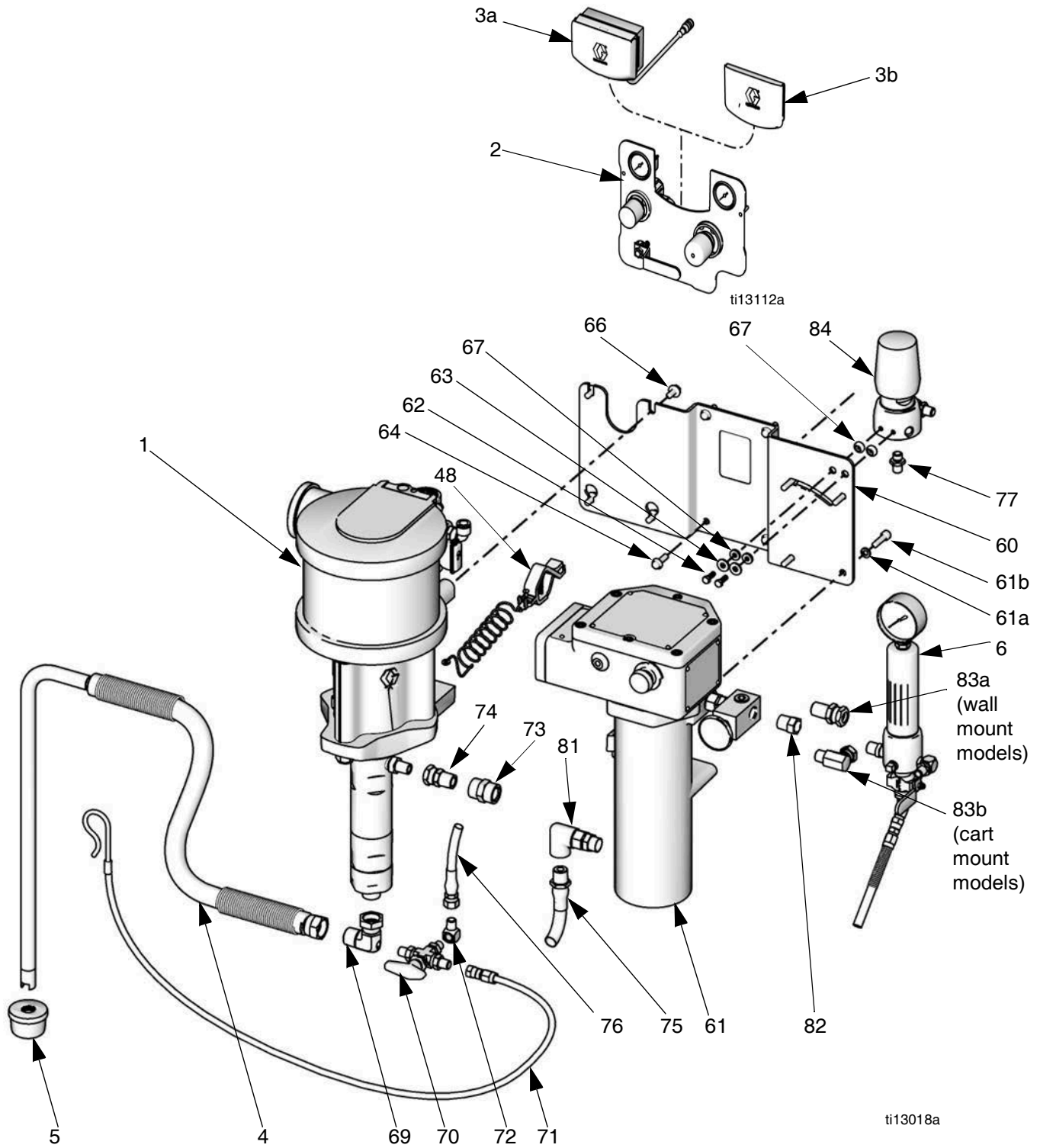

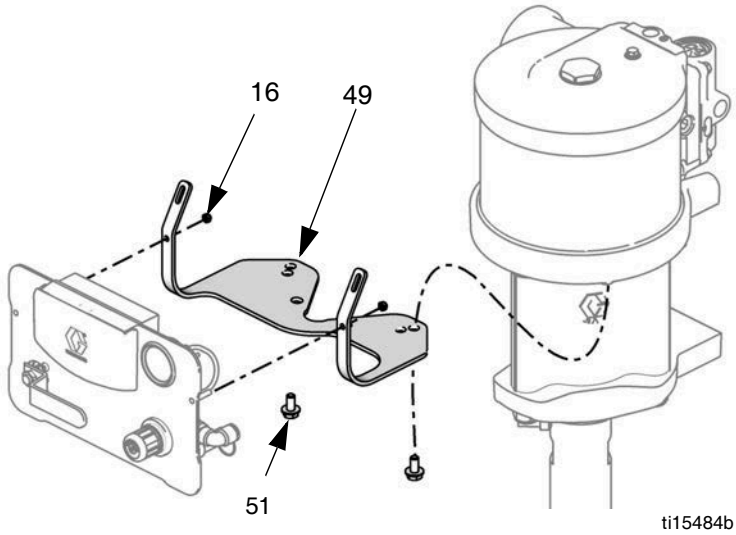

ti15484b

Non-Hazardous Location Electrical Cord Parts (Cart Mount Only)

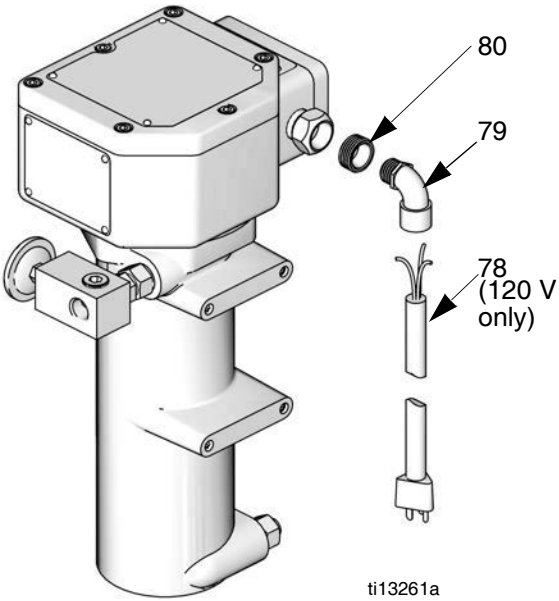

ti13261a

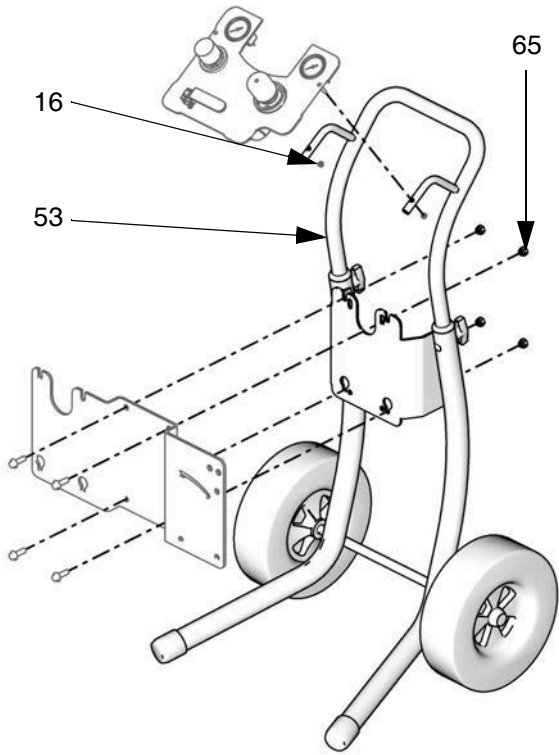

ti13114a

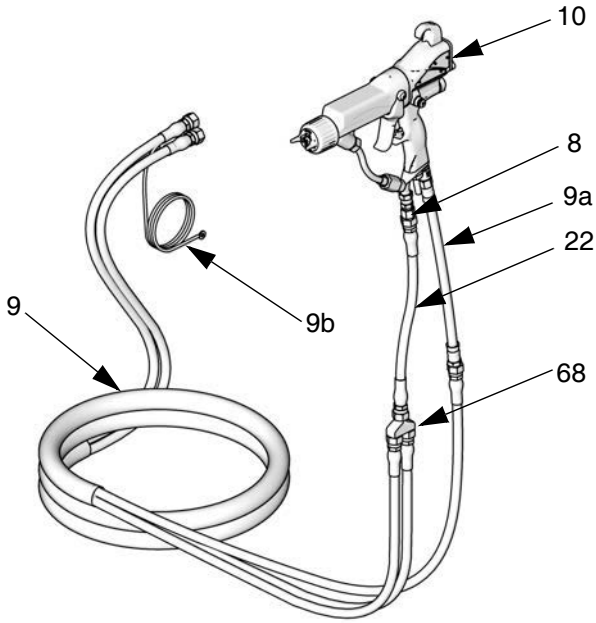

ti13260b

Heated Models (Continued)

Ref	Part	Description	Qty
1	Varies	Pump Assembly, <i>see Model tables, pages 9-13, and Manual 312794</i>	1
2	24A581	PANEL, air controls	1
3a	24A576	DATATRAK, assembly, <i>see manual 313541</i>	1
3b	-----	INSERT, panel (included with Part 2)	1
4	256422 256423	HOSE, suction, assembly (includes Part 5) G18xxx and G28xxx Models G30xxx Models	1
5	-----	STRAINER, suction (included with Part 4)	1
6	239300	FILTER, fluid, sst, <i>see manual 307273</i>	1
8	189018	SWIVEL, fluid hose	1
9	239352	HOSE BUNDLE, air and fluid	1
9a	236130	HOSE, air whip, 3 ft. (0.9 m)	1
9b	-----	GROUND WIRE, spray gun	1
10	H85M10	GUN, Pro Xp 85	1
11	AEM413	GUN TIP (not shown)	1
12	AEMxxx	TIP OPTION (not shown)	1
16	-----	NUT, lock, M5 x 0.08 (included with Part 49)	2
22	26B598	HOSE, fluid, whip, 2 ft (0.6 m)	1
48	238909	GROUND WIRE, pump	1
49	24E883	AIR CONTROLS MOUNTING KIT, wall mount, (includes 16 and 51)	1
51	-----	SCREW, hex head, M8 x 16 mm (included with Part 49)	2
53	256427	CART MOUNTING KIT, <i>see page 39</i> (GxxCxx models only)	1
54	24A578	WALL MOUNTING KIT, <i>see page 39</i> (GxxWxx models only)	1
60	24A590	BRACKET, heated, kit, includes 64, 65, and 66)	1
61	245848 245863	HEATER, fluid, includes 61a and 61b 120V, <i>see manual 309524</i> 240V, <i>see manual 309524</i>	1
61a	-----	WASHER	4
61b	-----	SCREW, M8 x 1.25 in.	4
62	100022	CAPSCREW, hex hd, 1/4-20 x 3/4 in. (19mm)	2
63	100527	WASHER, 1/4 in.	2
64	-----	SCREW, M8 x 25	4
65	-----	NUT	4
66	-----	SCREW, M8 x 1.25	4
67	167002	INSULATOR, heat	4
68	239864	MANIFOLD, recirculating, 1/4 npsm	1
69	15V521 15V522	UNION, swivel G18xxx and G28xxx Models G30xxx Models	1

Ref	Part	Description	Qty
70	113834	BALL VALVE, 3 way, 1/4 npt(m), sst	1
71	239062	HOSE, drain, nylon, sst fittings, 1/4 in. (6 mm) ID; 1/4 npsm(f)	1
72	166866	ELBOW, 1/4 npt (m x f), sst	2
73	117627	FITTING, coupler	1
74	114190 236892	UNION, swivel G18xxx and G28xxx Models G30xxx Models	1
75	239154	HOSE, fluid, nylon, sst fittings; 1/2 in (13 mm) ID, 1/2 npt (mbe), 19.5 in. (0.5 m) long	1
76	239108	HOSE, fluid, recirculation	1
77	166846	ADAPTER, 1/4-18 npsm x 1/4-18 npt	3
78	15W730	CORD, electrical (120V cart mount packages only)	1
79	112408	STRAIN RELIEF, 90° (120V cart mount packages only)	1
80	107219 185065	BUSHING For use with supplied cord (120V cart mount packages only), 3/4 npt(m) x 1/2 nptf Supplied with heater for conduit applications	1
81	113934	UNION, swivel, heater inlet, 90°, sst, 1/2 npt(fbe)	1
82	502265	BUSHING, reducer, pipe	1
83a	235207	UNION, swivel, sst, 3/8 npt(m) x 3/8 npsm(f), wall mount packages only	1
83b	207123	UNION, swivel, 90°, cart mount packages only	1
84	238926	REGULATOR, back pressure, sst, <i>see manual 306860</i>	1
85	15W718	LABEL, warning, not shown	1
86	15W719	LABEL, warning, not shown	1

▲ Replacement Warning labels, signs, tags, and cards are available at no cost.

Kits

Wall Mount Kit 24A578 (non-Bellows)

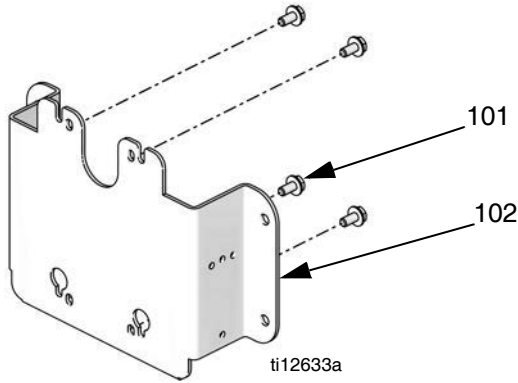

Ref.	Description	Qty
101	SCREW, cap, M8 x 1.25	4
102	PLATE, wall mount	1

NOTE: Air Controls Mounting Kit 24E883 also is required for wall mounting a package that has a control panel. See page 42.

Cart Mount Kit 256427 (non-Bellows)

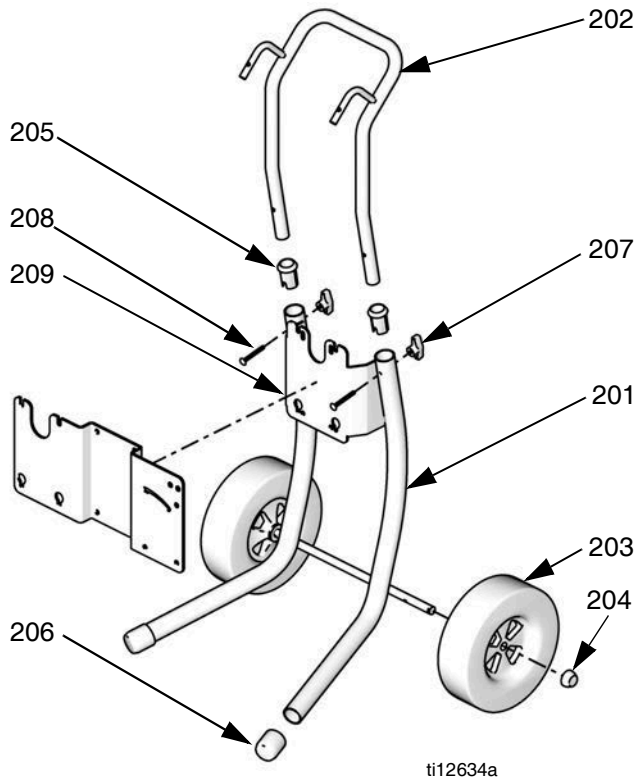

Ref.	Part	Description	Qty
201	----	CART, frame	1
202	----	HANDLE, cart	1
203	119451	WHEEL, semi-pneumatic	2
204	119452	CAP, hub	2
205	----	SLEEVE, cart handle	2
206	15C871	CAP, leg	2
207	115480	KNOB, t-handle	2
208	116630	SCREW, carriage	2
209	----	BRACKET, heater, cart	1

Bellows Cart Mount Kit 24E879

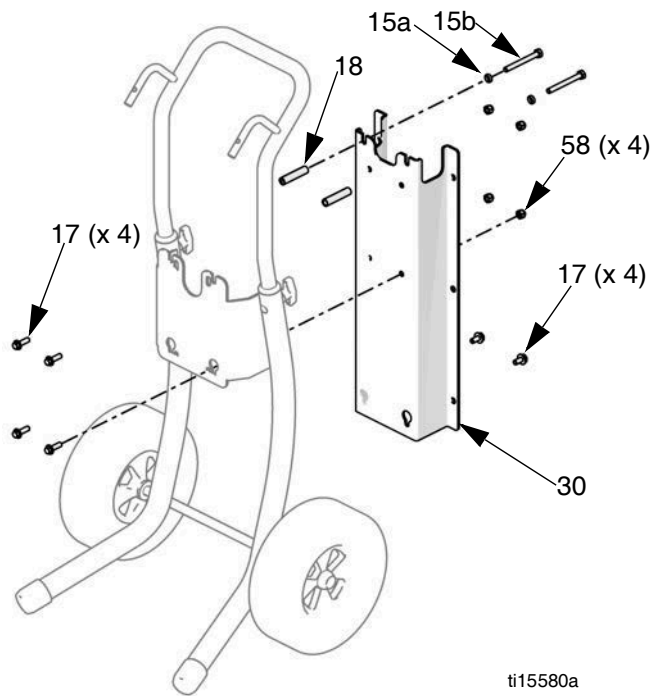

ti15580a

Ref	Description	Qty.
15a	Washer (not used)	2
15b	Screw (not used)	2
17	Screw, M8 x 16	8
18	Spacers (not used)	2
30	Plate, mounting	1
58	Lock nut, 13 mm	4

Bellows Air Control Mounting Kit

Kit 24E884 includes right and left mounting wedges (55 and 56), lock nuts (32) and screws (37).

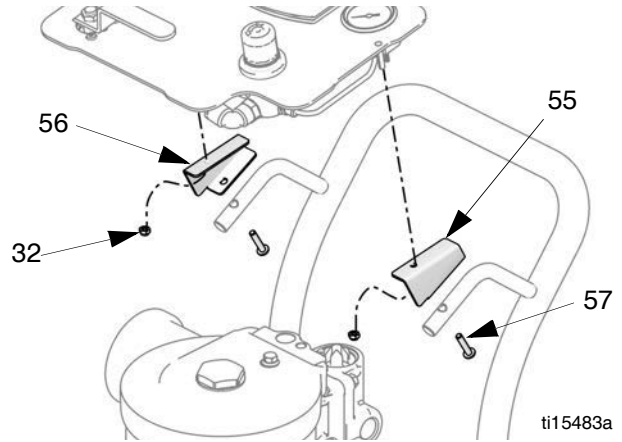

ti15483a

Pump and Gun Control Panel Kits

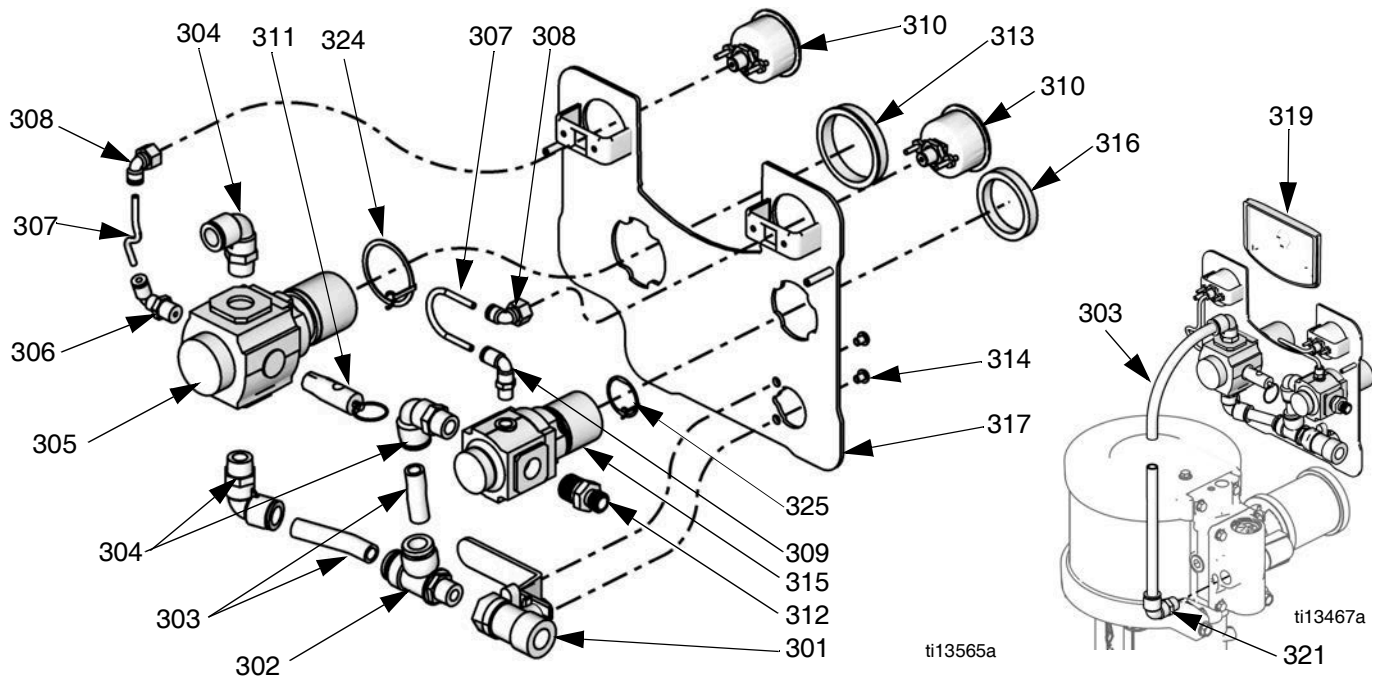

Kit 24A581 and Kit 24A584

Ref.	Part	Description	Qty.
301	114362	VALVE, ball	1
302	15T643	SWIVEL, tee, 3/8 npt(m) x 1/2T	1
303	-----	TUBE, 1/2 OD, cut to fit, order Tubing Kit 24D496	1.3 ft.
304	121212	ELBOW, swivel, 1/2T x 3/8 npt(m)	3
305	15T536	REGULATOR, air, pump, 3/8 npt	1
306	-----	ELBOW, swivel, 5/32 T x 1/4 npt	1
307	-----	TUBE, black, cut to fit, order Tubing Kit 24D496	4 in.
308	15T498	SWIVEL, 90°, 5/32T x 1/8 npt(f)	2
309	15T866	ELBOW, swivel, 5/32T x 1/8 npt	1
310	15T500	GAUGE, pressure	2
311	-----	VALVE, safety	1
	113498	Kit 24A581 (100 psi)	
	120306	Kit 24A584 (85 psi)	
312	164672	ADAPTER	1
313	15T538	NUT, regulator	1
314	114381	SCREW, cap, button head	2
315	15T539	REGULATOR, air, gun, 3/8 npt	1
316	116514	NUT, regulator	1
317	-----	PANEL	1
318	-----	LABEL, panel (not shown)	1
319	-----	INSERT	1
320	105332	NUT, lock (not shown)	2
321	-----	ELBOW, 1/2T x 1/2 npt	1
322	-----	COVER, lens, 12 sticker sheet (not shown), order Kit 24A540 for 5 sheets	1
324	24P814	RING, grounding	1
325	24P813	RING, grounding	1

Air Controls Mounting Kit (non-Bellows)

Includes one mounting bracket (49), two lock nuts (16), and two hex head screws (51).

Kit	Packages
24E883	Air Controls Mounting Kit, Wall Mount

5-Gallon Suction Hose Kits

Includes suction hose (4) and strainer (5).

Kit	Packages	Wall/Cart
256421	Ambient G23Cxx, G30Cxx	Cart
256422	Ambient: G15Cxx, G18Cxx, G24Cxx, G28Cxx Heated: G18xxx, G28xxx	Cart Both
256423	Ambient: G23Wxx, G30Wxx Ambient Bellows: G23Bxx, G35Bxx Heated: G30xxx	Wall Cart Both
256424	Ambient: G15Wxx, G18Wxx, G24Wxx, G28Wxxx Ambient Bellows: G15Bxx, G24Bxx	Wall Cart

55-Gallon Suction Hose Kits

Includes suction hose, bung adapter, and strainer.

24A954 - 3/4 in. hose

24B598 - 1 in. hose

PTFE Suction Hose Kits

For pumping acid materials that are compatible with PTFE. Includes suction hose, swivel, and strainer.

Kit	Description	Wall/Cart
24B337	3/4 in. hose, PTFE lined, with swivel elbow	Cart
24B338	1 in. hose, PTFE lined, with swivel elbow	Cart
24B424	3/4 in. hose, PTFE lined, with straight swivel	Wall
24B425	1 in. hose, PTFE lined, with straight swivel	Wall

DataTrak

NOTE: See DataTrak manual, 313541, for all DataTrak related part numbers and kit information, including the reed switch and solenoid.

Drain Valve Kit 256425

Includes drain valve (43), coupling (44), and hose(45).

Overflow Chamber Kit 24E298

Merkur Bellows models only. See Manual 312793. Includes overflow cup, with seals and necessary hardware.

Mounting Dimensions

Wall Bracket (Non-Bellows)

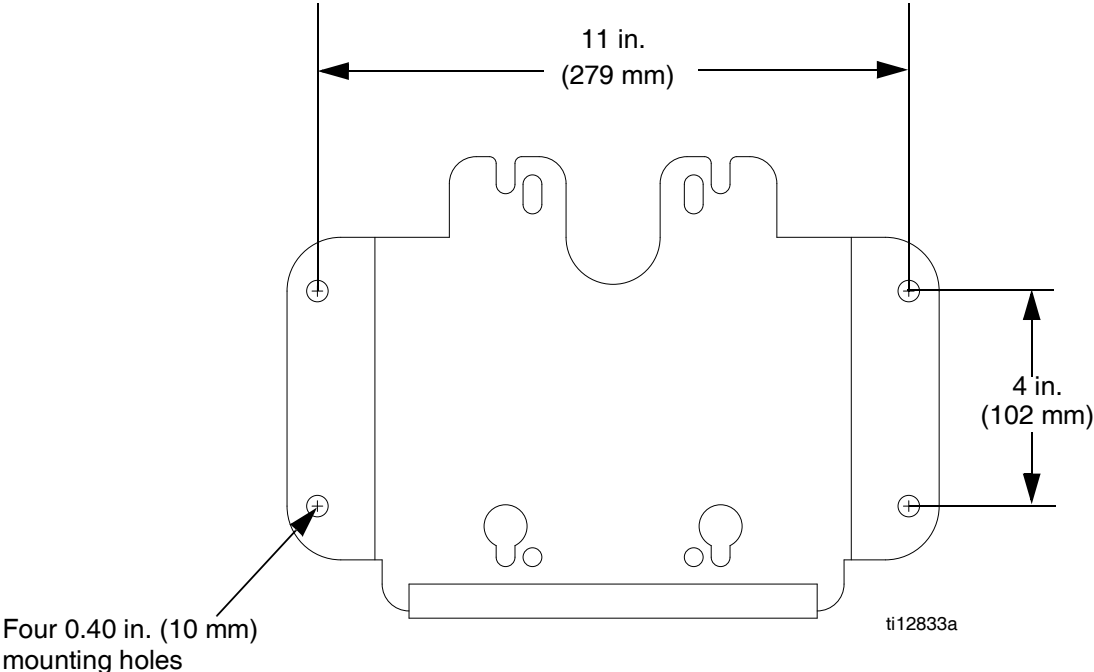

Technical Data

Merkur Electrostatic Spray Packages		
	U.S.	Metric
Maximum Fluid Working Pressure	See Models table on page 8.	
Maximum Fluid Inlet Pressure (Bellows)	15 psi	0.1 MPa, 1.0 bar
Maximum Pump Air Inlet Pressure	100 psi	0.7 MPa, 7.0 bar
Maximum Gun Air Inlet Pressure	100 psi	0.7 MPa, 7.0 bar
Ratio	See Models table on page 8.	
Ambient Air Temperature Range	35-120°F	2-49°C
Maximum Operating Temperature	120°F	49°C
Sound Data	See Technical Data in air motor manual 312796.	
Wetted Parts (displacement pump)	See manual 312792 (Merkur) or 312793 (Merkur Bellows).	
Wetted Parts (spray gun)	See manual 3A2495.	
Wetted Parts (fluid hoses)	nylon	
Wetted Parts (suction assembly)	stainless steel, nylon	
Wetted Parts (fluid filter)	See manual 307273.	
Wetted Parts (drain valve)	stainless steel, nylon	

California Proposition 65

CALIFORNIA RESIDENTS

 **WARNING:** Cancer and reproductive harm – www.P65warnings.ca.gov.

Package Weights

Ambient

Ratio, Package	Weight in lb (kg)
Cart Mount	
15:1, G15C85	104 (48)
15:1, G15C86	105 (48)
15:1, G15B83	129 (59)
15:1, G15B84	130 (60)
18:1, G18C09	103 (47)
18:1, G18C10	104 (48)
23:1, G23C15	101 (46)
23:1, G23C16	102 (47)
23:1, G23B33	125 (57)
23:1, G23B34	126 (58)
24:1, G24C13	106 (49)
24:1, G24C14	107 (49)
24:1, G24B33	129 (59)
24:1, G24B34	130 (60)
28:1, G28C13	106 (49)
28:1, G28C14	107 (49)
28:1, G28C23	107 (49)
28:1, G28C25	107 (49)

Ratio, Package	Weight in lb (kg)
30:1, G30C75	98 (45)
30:1, G30C76	99 (45)
30:1, G30C87	99 (45)
30:1, G30C89	99 (45)
35:1, G30B33	125 (57)
35:1, G30B34	126 (58)
Wall Mount	
15:1, G15W57	77 (36)
15:1, G15W58	78 (36)
18:1, G18W11	77 (36)
18:1, G18W12	78 (36)
23:1, G23W13	74 (34)
23:1, G23W14	75 (35)
24:1, G24W11	80 (37)
24:1, G24W12	81 (37)
28:1, G28W15	78 (36)
28:1, G28W16	79 (37)
30:1, G30W77	71 (33)
30:1, G30W78	72 (33)

Heated

Ratio, Package	Weight in lb (kg)
Cart Mount	
28:1, G28C19	174 (80)
28:1, G28C20	175 (80)
28:1, G28C21	174 (80)
28:1, G28C22	175 (80)
30:1, G30C81	165 (76)
30:1, G30C82	166 (76)
30:1, G30C83	165 (76)
30:1, G30C84	166 (76)

Ratio, Package	Weight in lb (kg)
Wall Mount	
18:1, G18W13	148 (68)
18:1, G18W14	149 (68)
28:1, G28W21	148 (68)
28:1, G28W22	149 (68)
28:1, G28W23	148 (68)
28:1, G28W24	149 (68)
30:1, G30W83	139 (64)
30:1, G30W84	140 (64)
30:1, G30W85	139 (64)
30:1, G30W86	140 (64)

Graco Standard Warranty

Graco warrants all equipment referenced in this document which is manufactured by Graco and bearing its name to be free from defects in material and workmanship on the date of sale to the original purchaser for use. With the exception of any special, extended, or limited warranty published by Graco, Graco will, for a period of twelve months from the date of sale, repair or replace any part of the equipment determined by Graco to be defective. This warranty applies only when the equipment is installed, operated and maintained in accordance with Graco's written recommendations.

This warranty does not cover, and Graco shall not be liable for general wear and tear, or any malfunction, damage or wear caused by faulty installation, misapplication, abrasion, corrosion, inadequate or improper maintenance, negligence, accident, tampering, or substitution of non-Graco component parts. Nor shall Graco be liable for malfunction, damage or wear caused by the incompatibility of Graco equipment with structures, accessories, equipment or materials not supplied by Graco, or the improper design, manufacture, installation, operation or maintenance of structures, accessories, equipment or materials not supplied by Graco.

This warranty is conditioned upon the prepaid return of the equipment claimed to be defective to an authorized Graco distributor for verification of the claimed defect. If the claimed defect is verified, Graco will repair or replace free of charge any defective parts. The equipment will be returned to the original purchaser transportation prepaid. If inspection of the equipment does not disclose any defect in material or workmanship, repairs will be made at a reasonable charge, which charges may include the costs of parts, labor, and transportation.

THIS WARRANTY IS EXCLUSIVE, AND IS IN LIEU OF ANY OTHER WARRANTIES, EXPRESS OR IMPLIED, INCLUDING BUT NOT LIMITED TO WARRANTY OF MERCHANTABILITY OR WARRANTY OF FITNESS FOR A PARTICULAR PURPOSE.

Graco's sole obligation and buyer's sole remedy for any breach of warranty shall be as set forth above. The buyer agrees that no other remedy (including, but not limited to, incidental or consequential damages for lost profits, lost sales, injury to person or property, or any other incidental or consequential loss) shall be available. Any action for breach of warranty must be brought within two (2) years of the date of sale.

GRACO MAKES NO WARRANTY, AND DISCLAIMS ALL IMPLIED WARRANTIES OF MERCHANTABILITY AND FITNESS FOR A PARTICULAR PURPOSE, IN CONNECTION WITH ACCESSORIES, EQUIPMENT, MATERIALS OR COMPONENTS SOLD BUT NOT MANUFACTURED BY GRACO. These items sold, but not manufactured by Graco (such as electric motors, switches, hose, etc.), are subject to the warranty, if any, of their manufacturer. Graco will provide purchaser with reasonable assistance in making any claim for breach of these warranties.

In no event will Graco be liable for indirect, incidental, special or consequential damages resulting from Graco supplying equipment hereunder, or the furnishing, performance, or use of any products or other goods sold hereto, whether due to a breach of contract, breach of warranty, the negligence of Graco, or otherwise.

FOR GRACO CANADA CUSTOMERS

The Parties acknowledge that they have required that the present document, as well as all documents, notices and legal proceedings entered into, given or instituted pursuant hereto or relating directly or indirectly hereto, be drawn up in English. Les parties reconnaissent avoir convenu que la rédaction du présente document sera en Anglais, ainsi que tous documents, avis et procédures judiciaires exécutés, donnés ou intentés, à la suite de ou en rapport, directement ou indirectement, avec les procédures concernées.

Graco Information

For the latest information about Graco products, visit www.graco.com.

For patent information, see www.graco.com/patents.

TO PLACE AN ORDER, contact your Graco distributor or call to identify the nearest distributor.

Phone: 612-623-6921 **or Toll Free:** 1-800-328-0211 **Fax:** 612-378-3505

All written and visual data contained in this document reflects the latest product information available at the time of publication. Graco reserves the right to make changes at any time without notice.

Original instructions. *This manual contains English. MM 312798*

Graco Headquarters: Minneapolis

International Offices: Belgium, China, Japan, Korea

GRACO INC. AND SUBSIDIARIES • P.O. BOX 1441 • MINNEAPOLIS MN 55440-1441 • USA
Copyright 2008, Graco Inc. All Graco manufacturing locations are registered to ISO 9001.

www.graco.com

Revision V, September 2022